

Features

- ◇ Trench Schottky Barrier technology
- ◇ Ultra low forward voltage drop
- ◇ Low power loss,high efficiency
- ◇ Excellent low reverse leakages
- ◇ Excellent high temperature stability
- ◇ High current capability
- ◇ High forward surge capability
- ◇ Lead free finish ,Rohs and WEEE compliant.

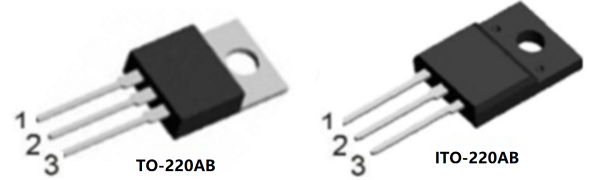

Applications

- ◇ Switching diode
- ◇ Switching mode power supply(SMPS)
- ◇ DC/DC converter
- ◇ LED lighting
- ◇ Adapter for notebook and game station

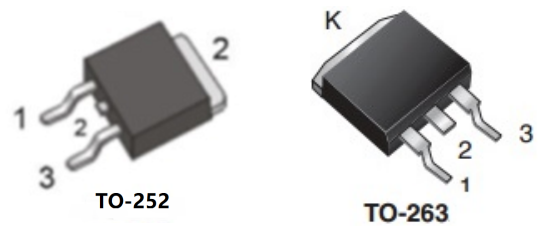

Mechanical Data

- ◇ Moisture Sensitivity: MSL Level 1,per J-STD-020
- ◇ Terminals:Matte Tin Finish.
Solderable per MIL-STD-202 Method 208
- ◇ Case Material: Molded Plastic;
Molding compound meet UL Flammability Classification Rating 94V-0
- ◇ Case:JEDEC TO-220AB,ITO-220AB,TO-252,TO-263

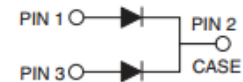

MAXIMUM RATING

Ratings at 25°C ambient temperature unless otherwise specified.

PARAMETER	SYMBOL	VALUE	UNITS	
Maximum repetitive peak reverse voltage	V_{RRM}	100	V	
Maximum RMS voltage	V_{RWS}	70	V	
Maximum DC blocking voltage	V_{DC}	100	V	
Maximum average forward rectified current	$I_{F(AV)}$	10	A	
per device Per diode		5		
Peak forward surge current 8.3ms half-sine-wave	I_{FSM}	150	A	
I^2t Rating for Fusing($t < 8.3ms$)	I^2t	93.375	A ² s	
Typical Thermal Resistance	TO-220AB	$R_{\theta JA}$	12.0	°C/W
		$R_{\theta JC}$	2.5	°C/W
		$R_{\theta JL}$	3.0	°C/W
	ITO-220AB	$R_{\theta JC}$	4.5	°C/W
	TO-252	$R_{\theta JC}$	2.5	°C/W
TO-263	$R_{\theta JC}$	2.5	°C/W	
Typical junction capacitance: $V_R=4.0v, f=1MHz$	C_J	380	pF	
Junction temperature	T_J	175	°C	
Storage temperature range	T_{STG}	-55~175	°C	

ELELTRICAL CHARACTERISTICS

PARAMETER	TEST CONDITIONS	SYMBOL	VALUE			UNITS	
			Min	Typ	Max		
Breakdown voltage per diode(min)	IR=0.5mA	V_{BR}	100	-	-	V	
Instantaneous forward voltage	IF=5A per leg	TA= 25°C	VF	-	0.82	0.85	V
		TA= 100°C	VF	-	0.75	-	V
		TA= 125°C	VF	-	0.73	-	V
	IF=3A per leg	TA= 25°C	VF	-	0.72	-	V
		TA= 100°C	VF	-	0.66	-	V
		TA= 125°C	VF	-	0.64	-	V
	IF=1A per leg	TA= 25°C	VF	-	0.62	-	V
		TA= 100°C	VF	-	0.60	-	V
		TA= 125°C	VF	-	0.58	-	V
Maximum DC reverse current @Rated DC Blocking Vlotage	TA= 25°C	IR	-	1.0	10	μ A	
	TA=125°C	IR	-	-	10000	μ A	

ODERING PACK INFORMATION

Part No.	Packge	Pcking	Box Size L×W×H(mm)	Quatity(pcs/box)	Carton Size L×W×H(mm)	Quatity(pcs/carton)
MBR10100CT	TO-220	50pcs/Tube	558×148×38	1000	565×225×170	5000
MBRF10100CT	ITO-220	50pcs/Tube	558×148×38	1000	565×225×170	5000
MBRD10100CT	TO-252	50pcs/Tube	558×148×38	1000	565×225×170	5000
MBRB10100CT	TO-263	50pcs/Tube	558×148×38	4000	565×225×170	20000

RATING AND CHARACTERISTICS CURVES

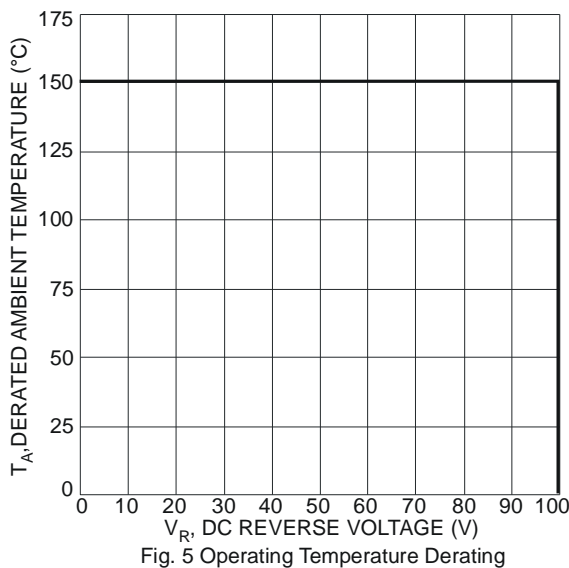
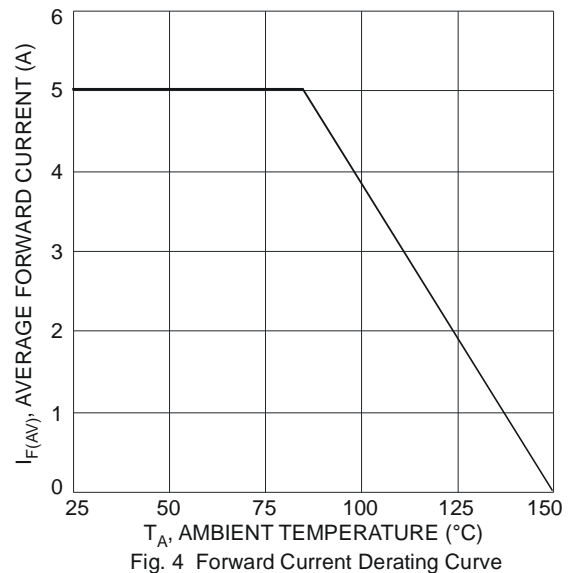
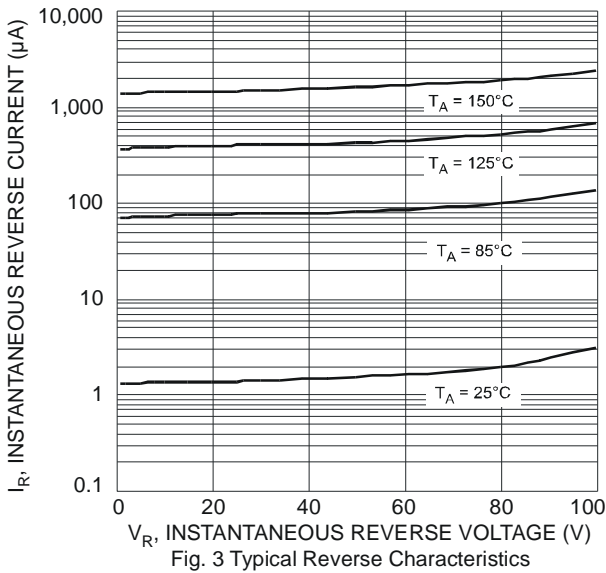
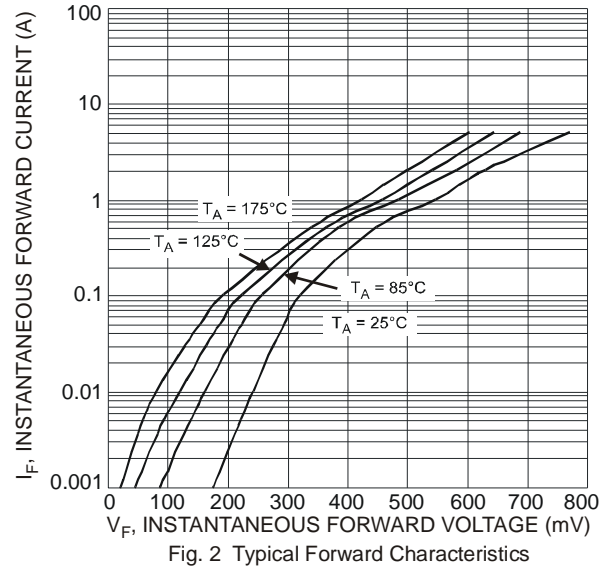
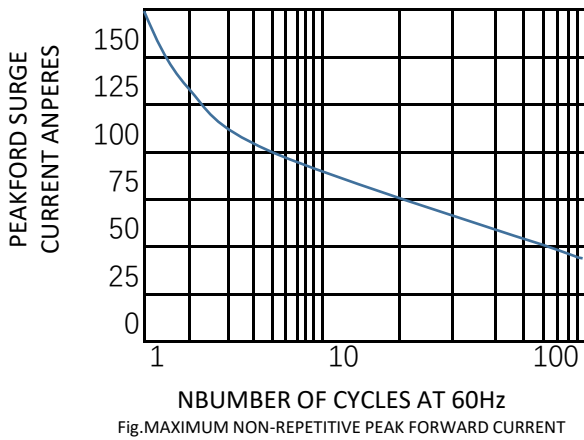

PACKAGE OUTLINE DIMENSIONS

Dimensions in inches and (millimeters)

TO-220AB

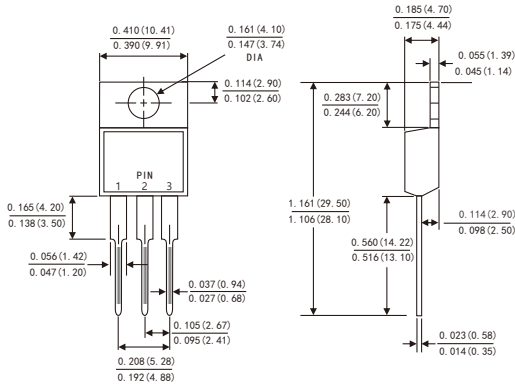

ITO-220AB

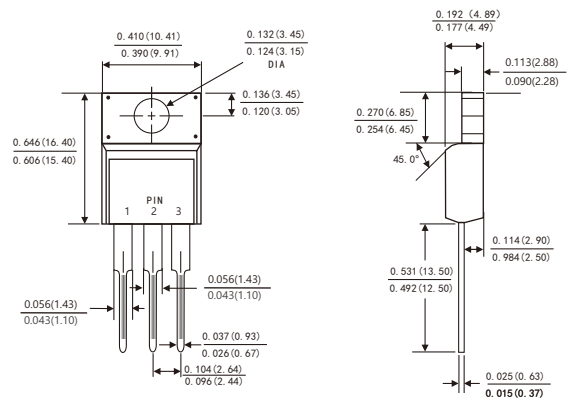

TO-263

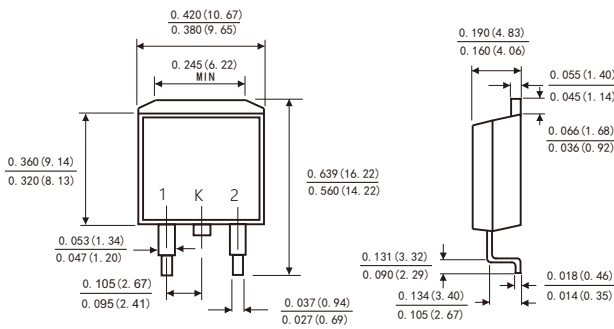

TO-252

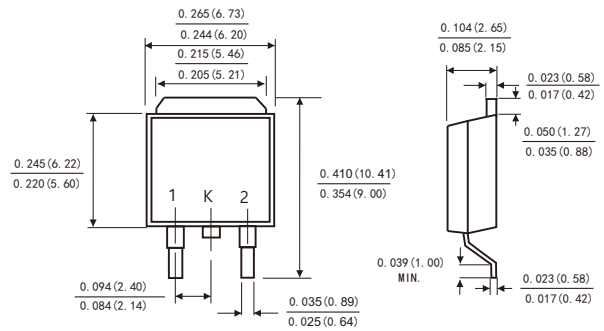

Suggested Pad Layout

(TO-263)

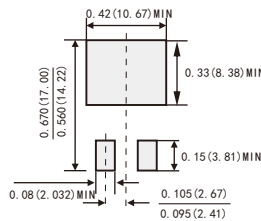

Suggested Pad Layout

(TO-252)

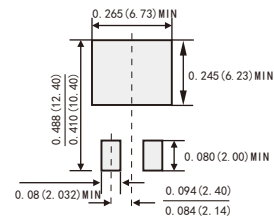

X-ON Electronics

Largest Supplier of Electrical and Electronic Components

Click to view similar products for [Schottky Diodes & Rectifiers](#) category:

Click to view products by [LGE](#) manufacturer:

Other Similar products are found below :

[MA4E2039](#) [MMBD301M3T5G](#) [RB160M-50TR](#) [D83C](#) [BAS16E6433HTMA1](#) [BAS 3010S-02LRH E6327](#) [BAT 54-02LRH E6327](#)
[NRVBAF360T3G](#) [NSR05F40QNXT5G](#) [NTE555](#) [JANS1N6640](#) [SS3003CH-TL-E](#) [GA01SHT18](#) [CRS10I30A\(TE85L,QM](#) [MBRA140TRPBF](#)
[MBRB30H30CT-1G](#) [BAT 15-04R E6152](#) [JANTX1N5712-1](#) [DMJ3940-000](#) [SB007-03C-TB-E](#) [NRVBB20100CTT4G](#) [NRVBM120LT1G](#)
[NTSB30U100CT-1G](#) [CRG04\(T5L,TEMQ\)](#) [ACDBA1100LR-HF](#) [ACDBA1200-HF](#) [ACDBA240-HF](#) [ACDBA3100-HF](#) [CDBQC0530L-HF](#)
[ACDBA260LR-HF](#) [ACDBA1100-HF](#) [10BQ015-M3/5BT](#) [NRVBM120ET1G](#) [VSSB410S-M3/5BT](#) [1N5819T-G](#) [PDS1040Q-13](#) [B160BQ-13-F](#)
[SDM05U20CSP-7](#) [BAS 70-07 E6433](#) [B140S1F-7](#) [HSM560Je3/TR13](#) [DDB2265-000](#) [ZHCS506QTA](#) [HSM190Je3/TR13](#) [B330AF-13](#)
[ACDBUC0230-HF](#) [SDM1U100S1F-7](#) [MBR10200CTF-G1](#) [CDLL5712](#) [DMF2822-000](#)