

Features

- ◇ Trench Schottky Barrier technology
- ◇ Ultra low forward voltage drop
- ◇ Low power loss,high efficiency
- ◇ Excellent low reverse leakages
- ◇ Excellent high temperature stability
- ◇ High current capability
- ◇ High forward surge capability
- ◇ Lead free finish ,Rohs and WEEE compliant.

Applications

- ◇ Switching diode
- ◇ Switching mode power supply(SMPS)
- ◇ DC/DC converter
- ◇ LED lighting
- ◇ Adapter for notebook and game station

Mechanical Data

- ◇ Moisture Sensitivity: MSL Level 1,per J-STD-020
- ◇ Terminals:Matte Tin Finish.
Solderable per MIL-STD-202 Method 208
- ◇ Case Material: Molded Plastic;
Molding compound meet UL Flammability Classification Rating 94V-0
- ◇ Case:JEDEC TO-220AB,ITO-220AB,TO-252,TO-263

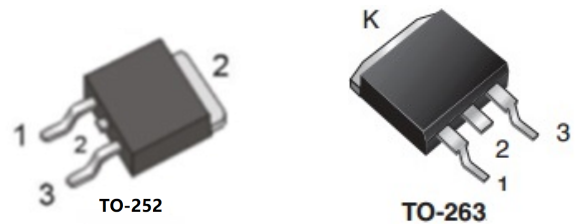
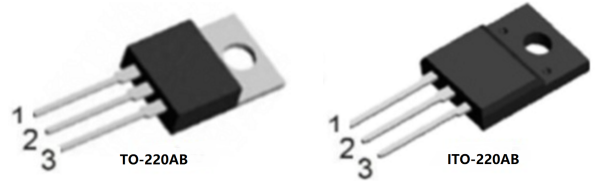

MAXIMUM RATING

Ratings at 25°C ambient temperature unless otherwise specified.

PARAMETER	SYMBOL	VALUE	UNITS
Maximum repetitive peak reverse voltage	V_{RRM}	200	V
Maximum RMS voltage	V_{RWS}	140	V
Maximum DC blocking voltage	V_{DC}	200	V
Maximum average forward rectified current	$I_{F(AV)}$	10	A
per device Per diode		5	
Peak forward surge current 8.3ms half-sine-wave	I_{FSM}	150	A
I^2t Rating for Fusing($t < 8.3ms$)	I^2t	93.375	A ² s
Typical Thermal Resistance	TO-220AB	$R_{\theta JA}$	12.0 °C/W
		$R_{\theta JC}$	2.5 °C/W
		$R_{\theta JL}$	3.0 °C/W
	ITO-220AB	$R_{\theta JC}$	4.5 °C/W
	TO-252	$R_{\theta JC}$	2.5 °C/W
TO-263	$R_{\theta JC}$	2.5 °C/W	
Typical junction capacitance: $V_R=4.0v, f=1MHz$	C_J	100	pF
Junction temperature	T_J	150	°C
Storage temperature range	T_{STG}	-55~150	°C

ELECTRICAL CHARACTERISTICS

PARAMETER	TEST CONDITIONS	SYMBOL	VALUE			UNITS	
			Min	Typ	Max		
Breakdown voltage per diode(min)	IR=0.5mA	VB _R	200	-	-	V	
Instantaneous forward voltage	IF=5.0A per leg	TA= 25°C	VF	-	0.80	0.85	V
		TA= 100°C	VF	-	0.70	-	V
		TA= 125°C	VF	-	0.67	-	V
	IF=3.0A per leg	TA= 25°C	VF	-	0.76	—	V
		TA= 100°C	VF	-	0.65	-	V
		TA= 125°C	VF	-	0.61	-	V
	IF=1.0A per leg	TA= 25°C	VF	-	0.62	-	V
		TA= 100°C	VF	-	0.60	-	V
		TA= 125°C	VF	-	0.58	-	V
Maximum DC reverse current @Rated DC Blocking Vlotage	TA= 25°C	IR	-	10.0	50	μ A	
	TA=125°C	IR	-	-	20000	μ A	

ORDERING PACK INFORMATION

Part No.	Package	Packing	Box Size L×W×H(mm)	Quantity(pcs/box)	Carton Size L×W×H(mm)	Quantity(pcs/carton)
MBR10200LCT	TO-220AB	50pcs/Tube	558×148×38	1000	570×290×180	5000
MBRF10200LCT	ITO-220AB	50pcs/Tube	558×148×38	1000	570×290×180	5000
MBRD10200LCT	TO-252	80pcs/Tube	560×178×38	4000	585×385×220	40000
MBRD10200LCT	TO-252	2500pcs/Reel	340×336×29	2500	353×346×365	25000
MBRB10200LCT	TO-263	50pcs/Tube	560×178×38	1000	585×385×220	10000
MBRB10200LCT	TO-263	800pcs/Reel	335×335×40	800	370×385×220	4800

RATING AND CHARACTERISTICS CURVES

FIG.1-FORWARD CURRENT DERATING CURVE

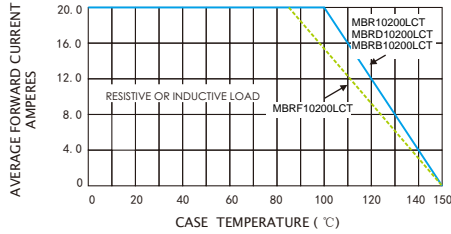

FIG.2-MAXIMUM NON-REPETITIVE PEAK FORWARD SURGE CURRENT

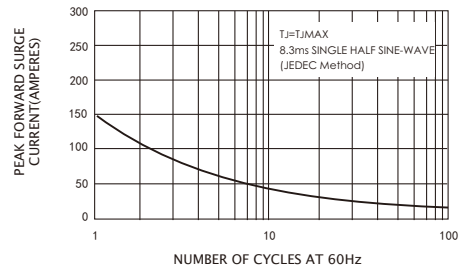

FIG.3-TYPICAL INSTANTANEOUS FORWARD CHARACTERISTICS

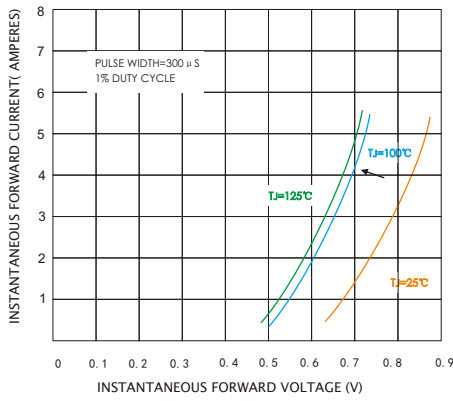

FIG.4-TYPICAL REVERSE CHARACTERISTICS

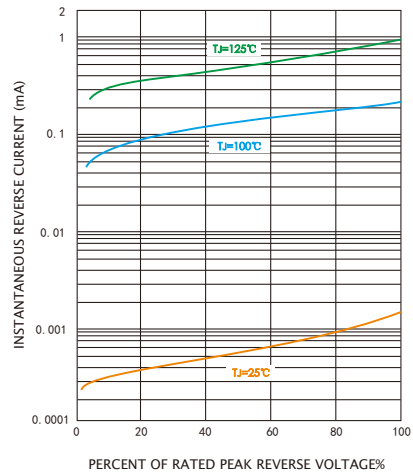
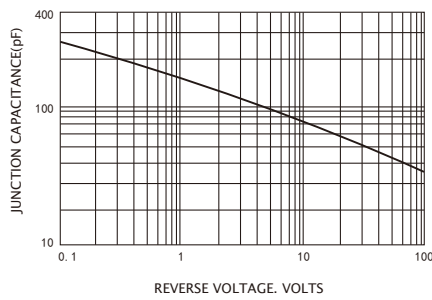

FIG.5-TYPICAL JUNCTION CAPACITANCE



PACKAGE OUTLINE DIMENSIONS

Dimensions in inches and (millimeters)

TO-220AB

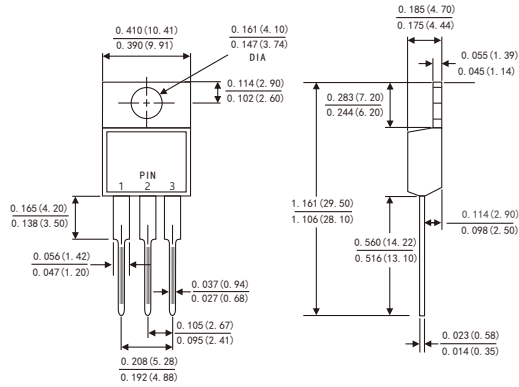

ITO-220AB

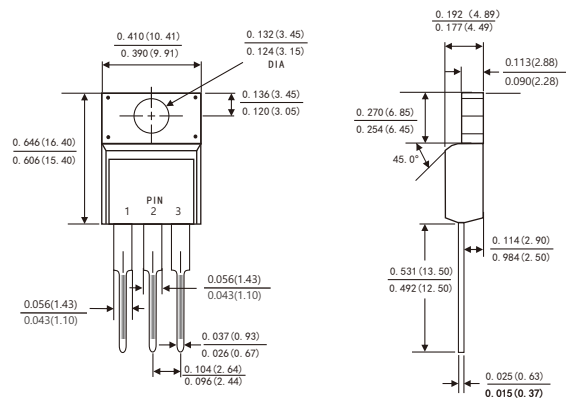

TO-263

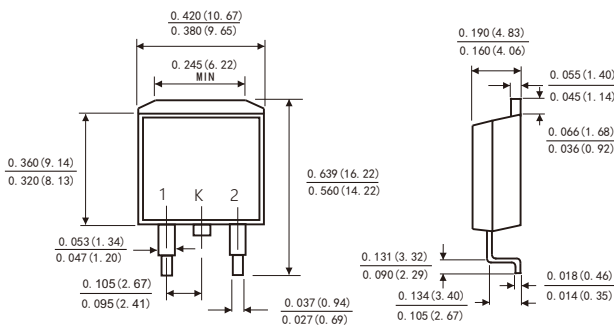

TO-252

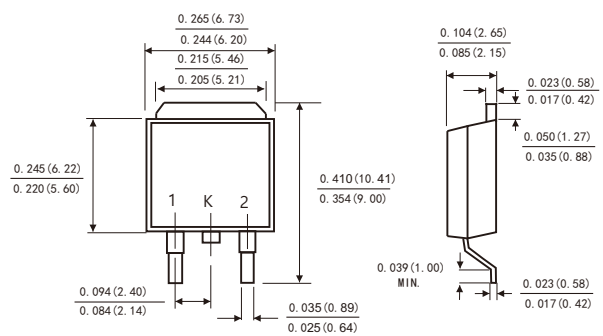

Suggested Pad Layout (TO-263)

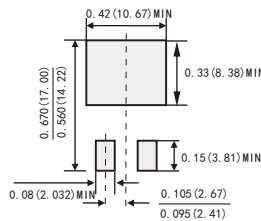

Suggested Pad Layout (TO-252)

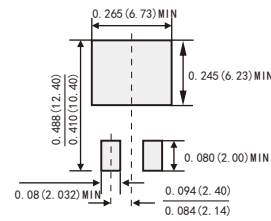

X-ON Electronics

Largest Supplier of Electrical and Electronic Components

Click to view similar products for [Schottky Diodes & Rectifiers](#) category:

Click to view products by [LGE](#) manufacturer:

Other Similar products are found below :

[MA4E2039](#) [MMBD301M3T5G](#) [RB160M-50TR](#) [D83C](#) [BAS16E6433HTMA1](#) [BAS 3010S-02LRH E6327](#) [BAT 54-02LRH E6327](#)
[NRVBAF360T3G](#) [NSR05F40QNXT5G](#) [NTE555](#) [JANS1N6640](#) [SS3003CH-TL-E](#) [GA01SHT18](#) [CRS10I30A\(TE85L,QM](#) [MBRA140TRPBF](#)
[MBRB30H30CT-1G](#) [BAT 15-04R E6152](#) [JANTX1N5712-1](#) [DMJ3940-000](#) [SB007-03C-TB-E](#) [NRVBB20100CTT4G](#) [NRVBM120LT1G](#)
[NTSB30U100CT-1G](#) [CRG04\(T5L,TEMQ\)](#) [ACDBA1100LR-HF](#) [ACDBA1200-HF](#) [ACDBA240-HF](#) [ACDBA3100-HF](#) [CDBQC0530L-HF](#)
[ACDBA260LR-HF](#) [ACDBA1100-HF](#) [10BQ015-M3/5BT](#) [NRVBM120ET1G](#) [VSSB410S-M3/5BT](#) [1N5819T-G](#) [PDS1040Q-13](#) [B160BQ-13-F](#)
[SDM05U20CSP-7](#) [BAS 70-07 E6433](#) [B140S1F-7](#) [HSM560Je3/TR13](#) [DDB2265-000](#) [ZHCS506QTA](#) [HSM190Je3/TR13](#) [B330AF-13](#)
[ACDBUC0230-HF](#) [SDM1U100S1F-7](#) [MBR10200CTF-G1](#) [CDLL5712](#) [DMF2822-000](#)