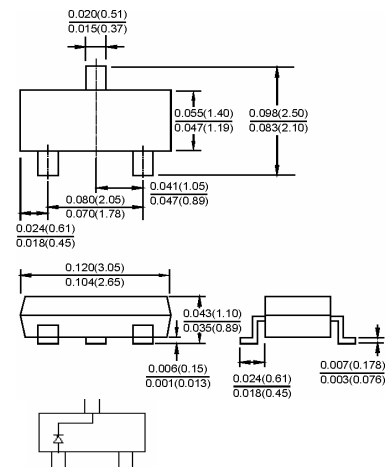

SOT-23

Dimensions in inches and (millimeters)

Features

- ✧ Fast switching speed.
- ✧ High conductance.
- ✧ For general purpose switching applications.
- ✧ Surface mount package ideally suited for automatic insertion.

Applications

- ✧ Small signal switching

Ordering Information

Type No.	Marking	Package Code
MMBD4148	KA2	SOT-23

MAXIMUM RATING @ Ta=25°C unless otherwise specified

Parameter	Symbol	Limits	Unit
Peak Repetitive Peak reverse voltage	V_{RRM}	75	V
Working Peak Reverse Voltage	V_{RWM}		
DC Reverse Voltage	V_R		
Non-repetitive peak reverse voltage	V_{RM}	100	V
RMS Reverse voltage	$V_{R(RMS)}$	53	V
Forward Continuous Current	I_{FM}	300	mA
Average rectified output Current	I_o	150	mA
Non-repetitive peak forward surge Current @t=1.0μs @t=1.0s	I_{FSM}	2.0 1.0	A
Power Dissipation	P_d	350	mW
Thermal resistance junction to ambient air	$R_{\theta JA}$	375	°C/W
Operating and storage temperature range	T_j, T_{STG}	-65 to 150	°C

ELECTRICAL CHARACTERISTICS @ Ta=25°C unless otherwise specified

Parameter	Symbol	Min.	Typ.	Max.	Unit	Conditions
Reverse breakdown voltage	$V_{R(BR)}$	75				$I_R=100\mu A$
Maximum Forward voltage	V_{FM}			0.715 0.855 1.0 1.25	V	$I_F=1.0mA$ $I_F=10mA$ $I_F=50mA$ $I_F=150mA$
Reverse current	I_{R1}			2.5	μA	$V_R=75V$
	I_{R2}			25	nA	$V_R=20V$
Diode Capacitance	C_D			2	pF	$V_R=0V, f=1MHz$
Reverse Recovery Time	t_{rr}			4	ns	$I_F=I_R=10mA, I_{rr}=0.1 * I_R, R_L=100\Omega$

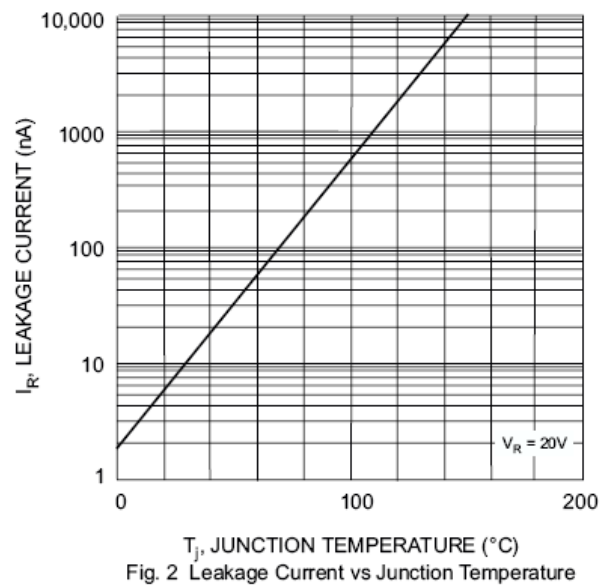
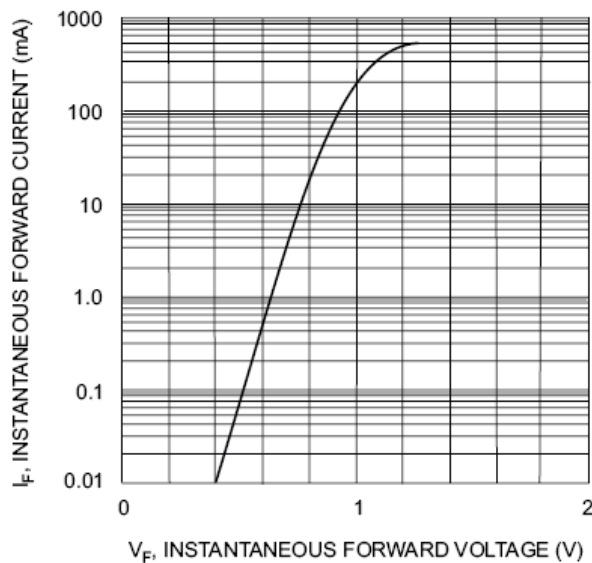
TYPICAL CHARACTERISTICS @ Ta=25°C unless otherwise specified

PACKAGE	SPQ/PCS	CARTON SPQ/PCS	CARTON SIZE/CM	CARTON GW/KG	CARTON NW/KG
SOT-23	3000/REEL	90000	40X20X22	5.00	4.00

X-ON Electronics

Largest Supplier of Electrical and Electronic Components

Click to view similar products for [Diodes - General Purpose, Power, Switching category:](#)

Click to view products by [LGE manufacturer:](#)

Other Similar products are found below :

[MCL4151-TR3](#) [MMBD3004S-13-F](#) [RD0306T-H](#) [1N3611](#) [NTE156A](#) [NTE574](#) [NTE6244](#) [1SS193,LF](#) [1SS400CST2RA](#) [SDAA13](#)
[SHN2D02FUTW1T1G](#) [LS4151GS08](#) [1N4449](#) [1N456A](#) [1N4934-E3/73](#) [1N914BTR](#) [RFUH20TB3S](#) [D291S45T](#) [BAV300-TR](#) [BAW56DWQ-](#)
[7-F](#) [BAW75-TAP](#) [MM230L-CAA](#) [IDW40E65D1](#) [JAN1N3600](#) [JAN1N4454UR-1](#) [LL4151-GS18](#) [SMMSD4148T3G](#) [BYW95B/A52A](#)
[NSVDAN222T1G](#) [CDSZC01100-HF](#) [LL4150-M-08](#) [1N4454-TR](#) [BAV70HDW-7](#) [BAS28-7](#) [JANTX1N6640](#) [BAW56HDW-13](#) [BAS28 TR](#)
[VS-HFA04SD60STR-M3](#) [NSVM1MA152WKT1G](#) [1SS388-TP](#) [RGP30D-E3/73](#) [VS-8EWF02S-M3](#) [BAV99TQ-13-F](#) [BAV99HDW-13](#)
[MMDB30-E28X](#) [IDP20C65D2XKSA1](#) [LS4148](#) [IDV15E65D2](#) [NSVM1MA152WAT1G](#) [HN4D02JU\(TE85L,F\)](#)