

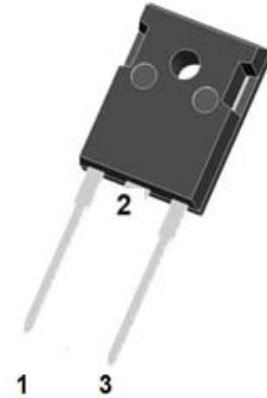

Features

- Adopt FRED chip
- Low forward Voltage drop
- Fast reverse recovery time
- High frequency operation
- High purity, high temperature epoxy encapsulation for enhanced mechanical strength and moisture resistance
- Guard ring for enhanced ruggedness and long term reliability

TO-247AC



Typical Applications

- Typical applications are in switching power supplies, converters, freewheeling diodes, and reverse battery protection.

Mechanical Data

- **Package:** TO-247AC
Molding compound meets UL 94 V-0 flammability rating, RoHS-compliant
- **Terminals:** Tin plated leads, solderable per J-STD-002 and JESD22-B102
- **Polarity:** As marked

TYPE	V _{RSM} V	V _{RRM} V
MUR60120	1200	1200

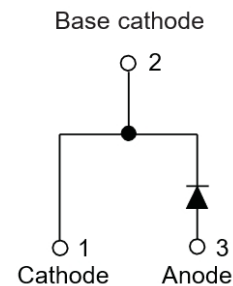

Symbol	Test Conditions	Maximum Ratings	Unit
I _{FRMS}	T _{VJ} =T _{VJM}	100	A
I _{FAVM}	T _C =60°C; rectangular, d=0.5	52	
I _{FRM}	t _p <10us; rep. rating, pulse width limited by T _{VJM}	800	
I _{FSM}	T _{VJ} =45°C t=10ms (50Hz), sine t=8.3ms (60Hz), sine	500 540	A
	T _{VJ} =150°C t=10ms(50Hz), sine t=8.3ms(60Hz), sine	450 480	
I ² t	T _{VJ} =45°C t=10ms (50Hz), sine t=8.3ms (60Hz), sine	1250 1200	A ² s
	T _{VJ} =150°C t=10ms(50Hz), sine t=8.3ms(60Hz), sine	1000 950	
T _{VJ} T _{VJM} T _{stg}		-40...+150 150 -40...+150	°C
P _{tot}	T _C =25°C	189	W
M _d	Mounting torque	0.8...1.2	Nm
Weight		6	g

■Electrical Characteristics

Symbol	Test Conditions	Characteristic Values		Unit
		typ.	max.	
I_R	$T_{VJ}=25^{\circ}\text{C}; V_R=V_{RRM}$		2.2	mA
	$T_{VJ}=25^{\circ}\text{C}; V_R=0.8 \cdot V_{RRM}$		0.5	
	$T_{VJ}=125^{\circ}\text{C}; V_R=0.8 \cdot V_{RRM}$		14	
V_F	$I_F=60\text{A}; T_{VJ}=150^{\circ}\text{C}$		2.0	V
	$T_{VJ}=25^{\circ}\text{C}$		2.55	
V_{TO}	For power-loss calculations only		1.65	V
r_T	$T_{VJ}=T_{VJM}$		8.3	mΩ
R_{thJC} R_{thCK} R_{thJA}		0.25	0.66	K/W
			35	
t_{rr}	$I_F=1\text{A}; -di/dt=200\text{A}/\mu\text{s}; V_R=30\text{V}; T_{VJ}=25^{\circ}\text{C}$	40	60	ns
I_{RM}	$V_R=540\text{V}; I_F=60\text{A}; -di_F/dt=480\text{A}/\mu\text{s}; L \leq 0.05\mu\text{H}; T_{VJ}=100^{\circ}\text{C}$	32	36	A

■Thermal Characteristics (T_j=25°C Unless otherwise specified)

PARAMETER		SYMBOL	UNIT	MUR60120P
Thermal Resistance	Between junction and case	R _{θJ-C}	°CW	1.0
	Between junction and Air	R _{θJ-A}	°CW	50

■ Characteristics(Typical)

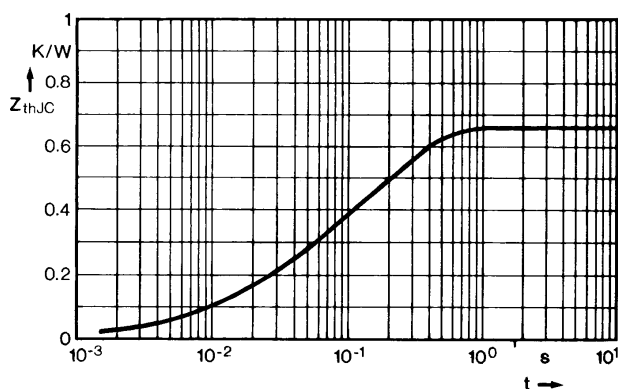

Fig. 7 Transient thermal impedance junction to case.

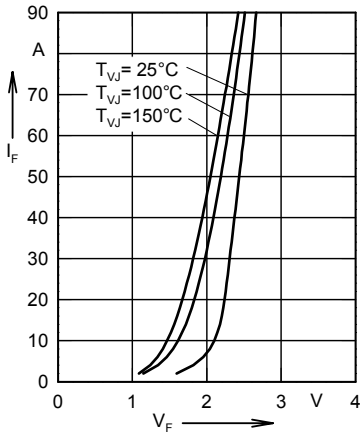

Fig. 1 Forward current versus voltage drop.

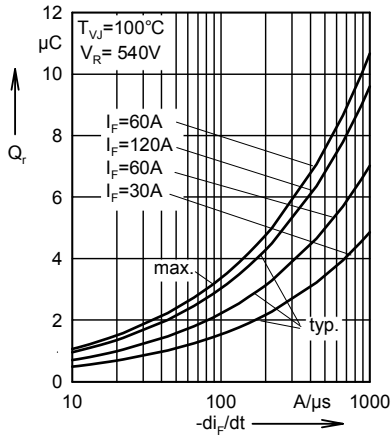

Fig. 2 Recovery charge versus $-di_F/dt$.

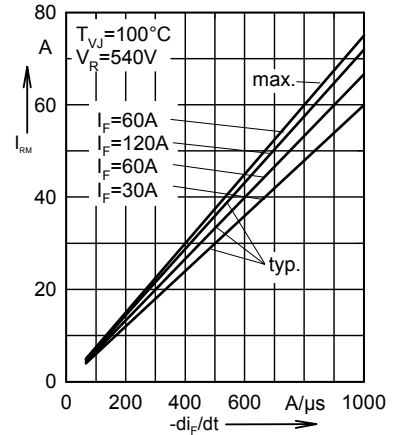

Fig. 3 Peak reverse current versus $-di_F/dt$.

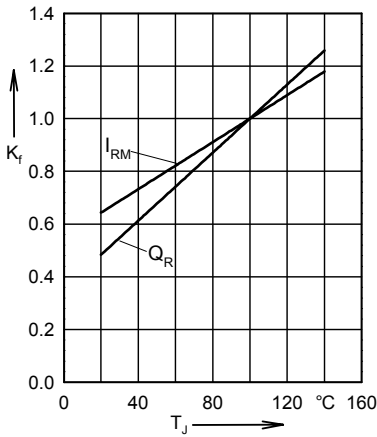

Fig. 4 Dynamic parameters versus junction temperature.

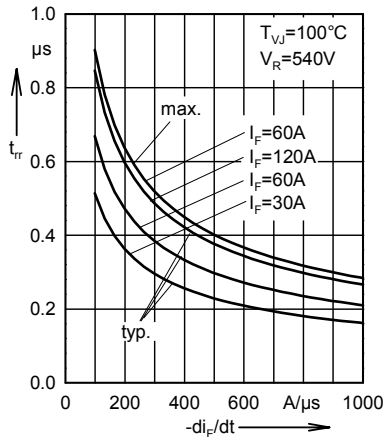

Fig. 5 Recovery time versus $-di_F/dt$.

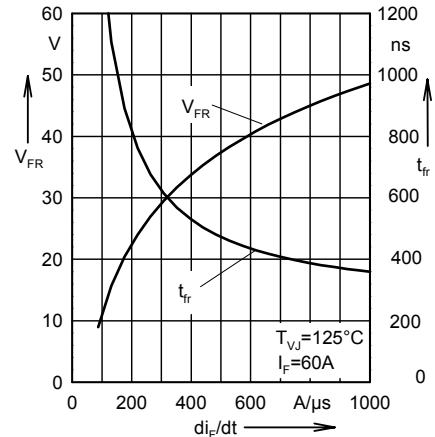
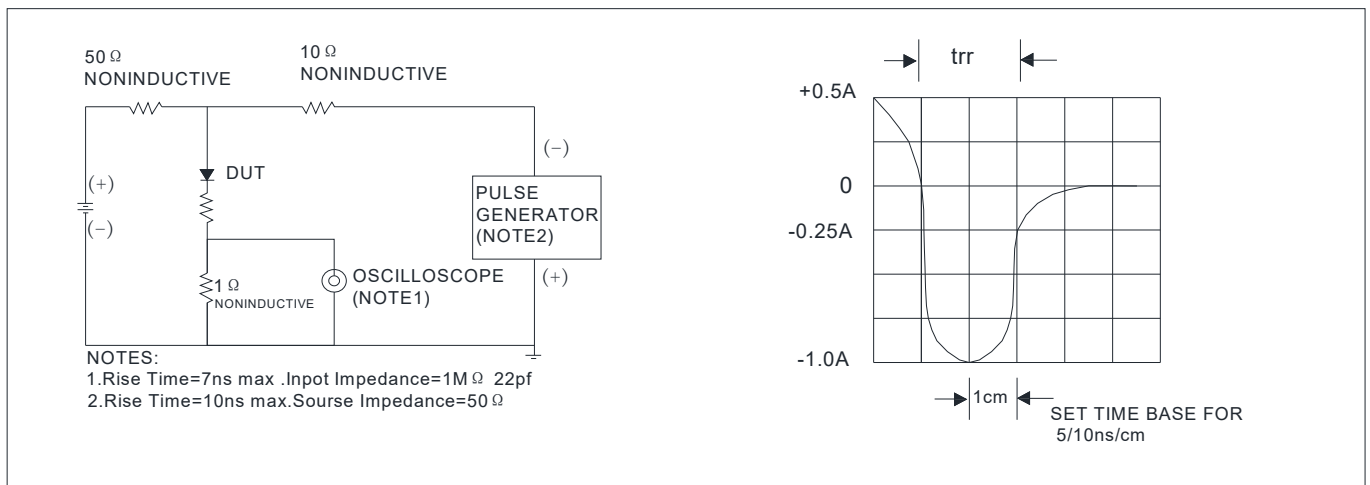
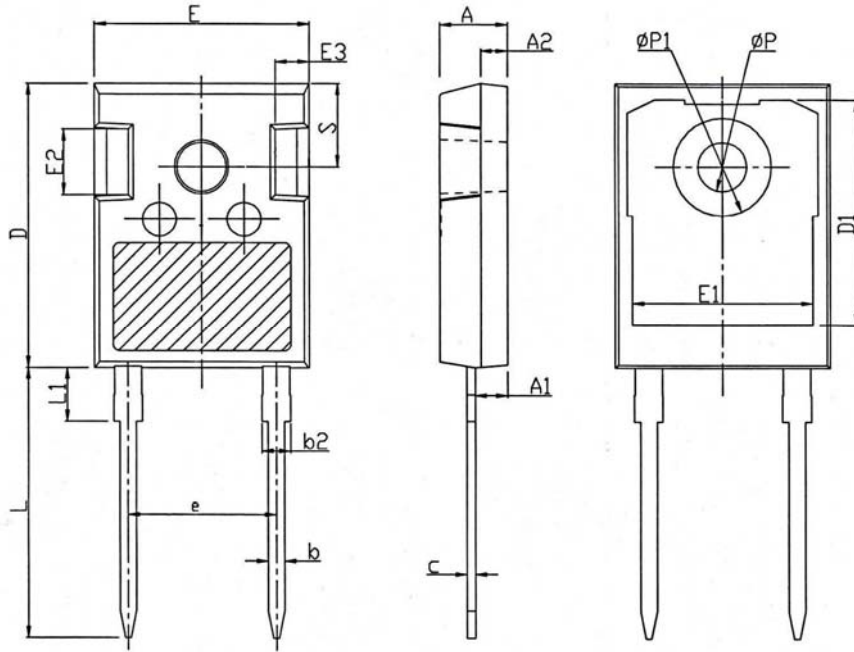

Fig. 6 Peak forward voltage versus di_F/dt .

FIG.5: Diagram of circuit and Testing wave form of reverse recovery time



■ Outline Dimensions

TO247-AC		
Dim	Min	Max
A	4.80	5.20
A1	2.21	2.61
A2	1.85	2.15
b	1.11	1.36
b2	1.91	2.21
c	0.51	0.75
D	20.70	21.30
D1	16.25	16.85
E	15.50	16.10
E1	13.00	13.60
E2	4.80	5.20
E3	2.30	2.70
e	10.88 TYP	
L	19.62	20.22
L1	-	4.30
φP	3.40	3.80
φP1	-	7.30
S	6.15 TYP	

X-ON Electronics

Largest Supplier of Electrical and Electronic Components

Click to view similar products for [Rectifiers](#) category:

Click to view products by [LGE](#) manufacturer:

Other Similar products are found below :

[70HFR40](#) [FR105 R0](#) [RL252-TP](#) [1N5397](#) [1N4005-TR](#) [1N4007-BP](#) [UFS120Je3/TR13](#) [20ETS12S](#) [RRE02VS6SGTR](#) [MS306](#) [A1N5404G-G](#)
[CRF02\(T5L,TEMQ\)](#) [ACGRB207-HF](#) [CLH07\(TE16L,Q\)](#) [CLH03\(TE16L,Q\)](#) [1N5395-TP](#) [UES1302](#) [ACGRC307-HF](#) [ACEFC304-HF](#) [DZ-](#)
[1380](#) [85HFR60](#) [40HFR60](#) [70HF120](#) [85HFR80](#) [SCF7500](#) [SM100](#) [ACGRA4001-HF](#) [SKN70/08](#) [NTE5819](#) [NTE5827](#) [NTE5828](#) [NTE5911](#)
[NTE5915](#) [NTE6104](#) [NTE6163](#) [NTE6164](#) [NTE6165](#) [NTE6364](#) [TSD3G](#) [SET130312](#) [NRVUS110VT3G](#) [UES1106](#) [UES1306](#)
[NRVUS240VT3G](#) [D5FE60-5063](#) [R4000GPS-TP](#) [D4015L56TP](#) [UES1306HR2](#) [FX20K120](#) [D20XB60-7101](#)