

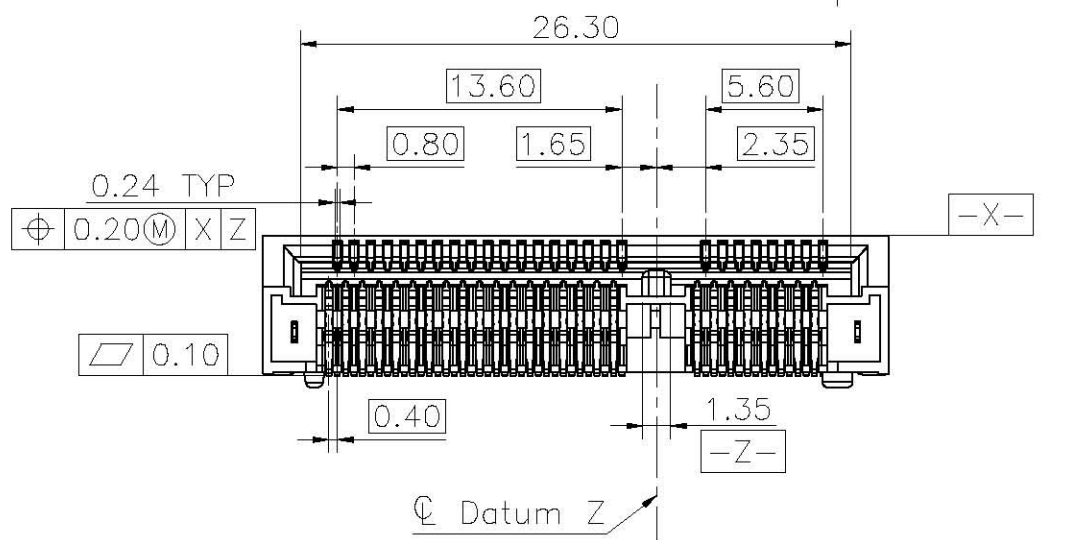

REV.	ECR/N NO./DESCRIPTION	DATE	DRAWN	CHECKED	APPROVE
1	N110006	12/08'10	Cary He	Kelvin_Yao	Richard Zhu
2	N110097	04/01'11	Cary He	Kelvin_Yao	Richard Zhu
3	SN12142 正式版本發行	07/02'12	Tracy	Vito	Barney

- Datum X is the top surface of Product
- (1) The horizontal axis for the pattern is established by a line through the center of the $\varnothing 1.45$ and $\varnothing 0.95$ posts.
(2) The vertical axis is 90° to the horizontal axis, through the center of datum Y.

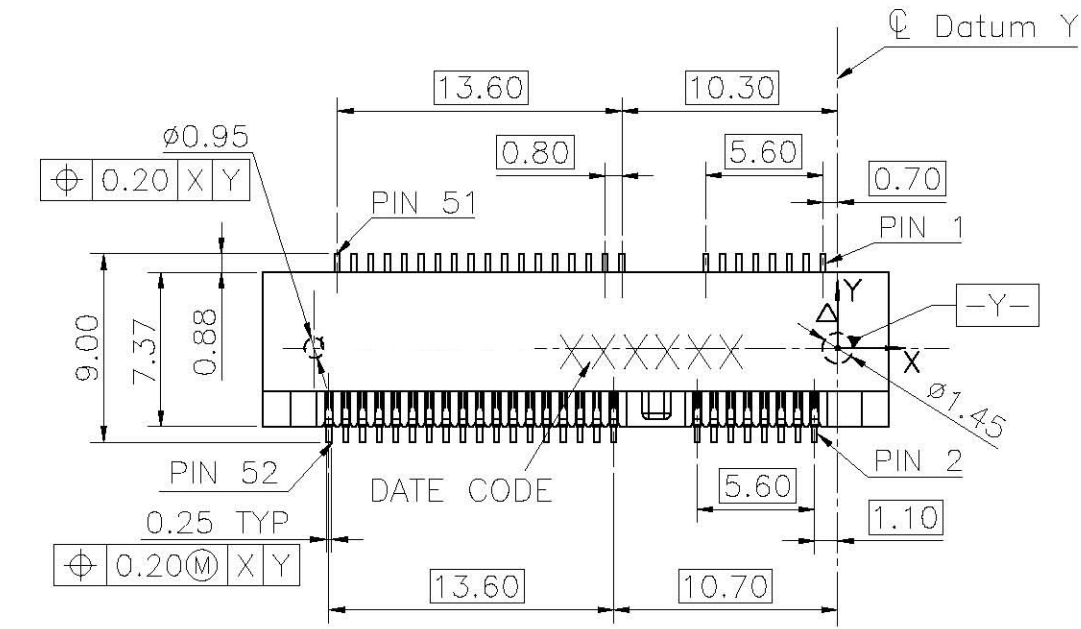
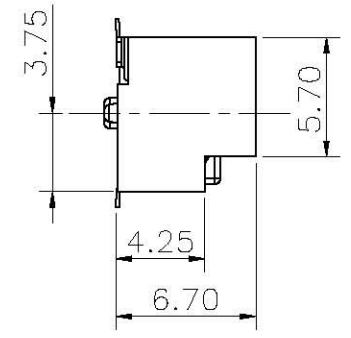
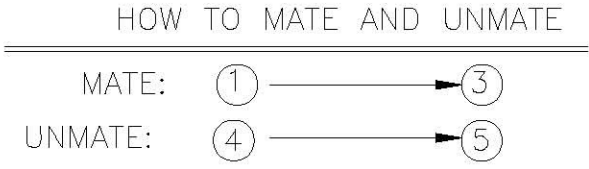
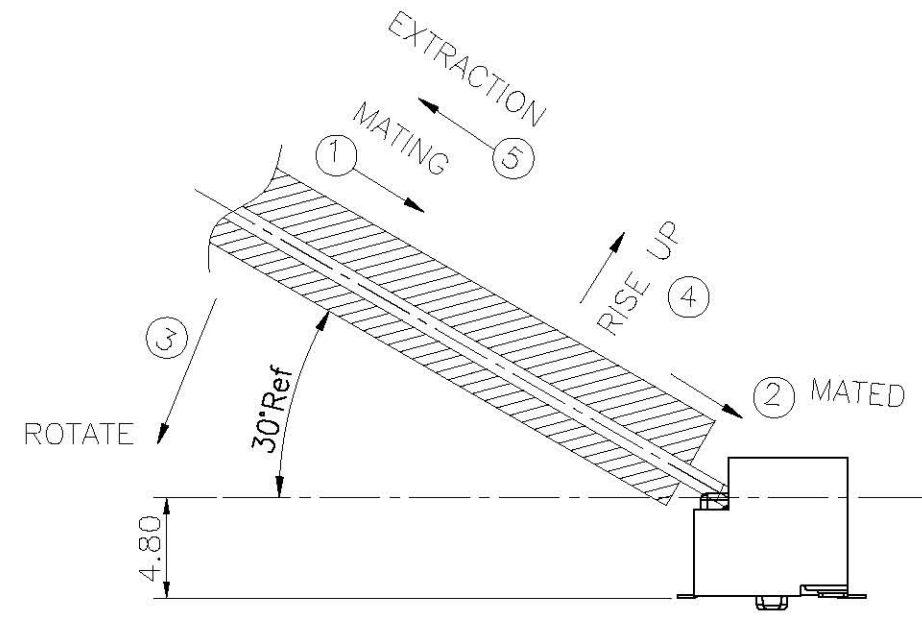
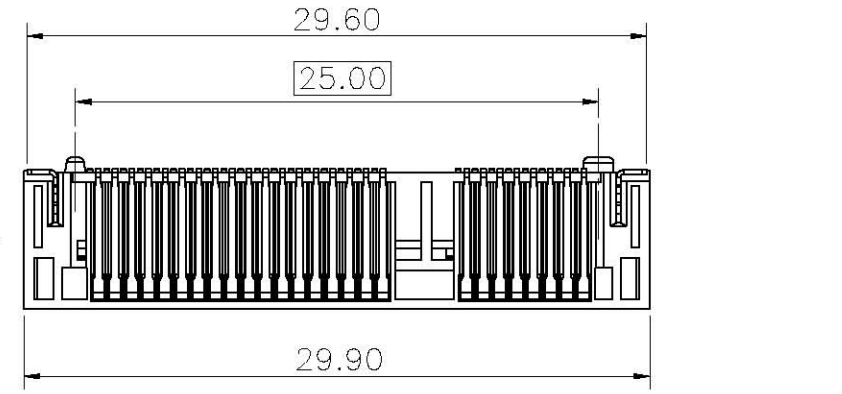

TABLE

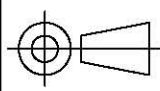
3	AAA-PCI-073-P07	BLACK	✓	BRASS C2680_Au 10u"						
2	AAA-PCI-073-P08	BLACK	✓	BRASS C2680_Au 1u" MIN						
1	AAA-PCI-073-P09	BLACK	✓	BRASS C2680_Au 30u"						
NO.	PART NO.	COLOR	LOGO	DESCRIPTION						
GENERAL TOLERANCES UNLESS SPECIFIED		PART NO. SEE TABLE		 连欣科技 Lian Xin Technology						
$X \pm 0.35$	$X^\circ \pm 3^\circ$	APPROVED BY Barney			TITLE MINI PCI EXPRESS 6.7H 0.8PITCH 52P					
$.XX \pm 0.25$	$X^\circ \pm 2^\circ$	CHECKED BY Vito		DWG NO. AP-AAA-PCI-073						
$.XXX \pm 0.15$	$XX^\circ \pm 1^\circ$	CUSTOMER DRAWING								
SIZE A4	UNITS MM	DRAWN BY XU		 <table border="1"> <thead> <tr> <th>SHEET</th> <th>SCALE</th> <th>REV</th> </tr> </thead> <tbody> <tr> <td>1 / 5</td> <td>2 : 1</td> <td>3</td> </tr> </tbody> </table>	SHEET	SCALE	REV	1 / 5	2 : 1	3
SHEET	SCALE	REV								
1 / 5	2 : 1	3								

NOTES:

1.MATERIAL:

- 1).HOUSING: LCP BLACK UL94V-0.
- 2).CONTACT: PHOSPHOR BRONZE OR BRASS (SEE TABLE).
- 3).PADS: BRASS .

2.FINISH:

2.1 CONTACTS:

- 1).50u"MIN Ni UNDER PLATED OVER ALL.
- 2).Au PLATING ON CONTACT AREA (SEE TABLE).
- 3).MATTE-Tin 100u"MIN ON SOLDER AREA.

2.2 PADS:

- 1).60u"MIN Ni UNDER PLATED OVER ALL.
- 2).MATTE-Tin 100u"MIN ON SOLDER AREA.

3.MECHANICAL PERFORMANCE,

MATING & UNMATING FORCE: 2.3 Kgf MAX.

4.ELECTRICAL PERFORMANCE,

- 4-1.VOLTAGE RATING: 50 V AC PER CONTACT.
CURRENT RATING: 0.5 A.
- 4-2.LLCR:INITIAL 55mΩ MAX PER CONTACT..
FINAL 20mΩ MAX
- 4-3.INSULATION RESISTANCE:
500MΩ MIN
- 4-4.DIELECRIC WITHSTAND VOLTAGE:
AC 300V FOR 1 MINUTE BETWEEN ADJACENT CONTACTS.
NO BREAKDOWN OR FLASH.
CURRENT LEAKAGE:1mA.

5. IR REFLOW:

THE PEAK TEMPRATURE ON THE BOARD SHALL BE MAINTAINED FOR 10 SECONDS AT 260±5°C.

6. AAA-PCI-073-P** : HF COMPLIANT.

7. DC: XXXXXX

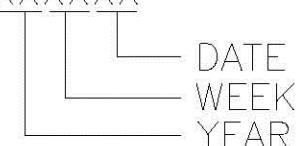

8. PRODUCT NO:AAA-PCI-***-***

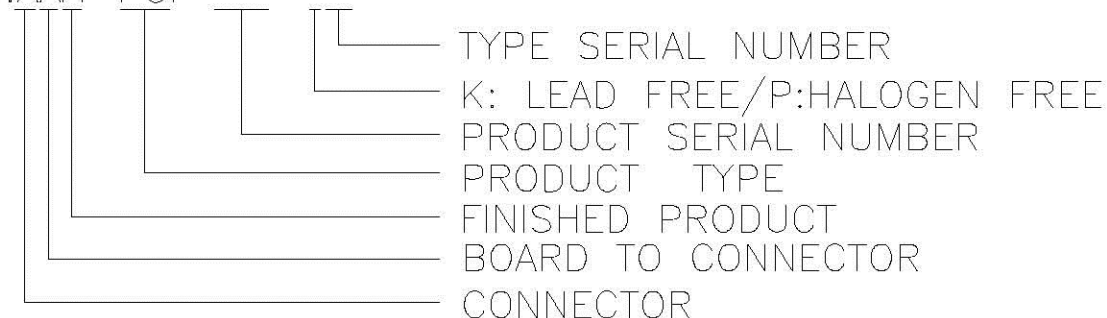

GENERAL TOLERANCES UNLESS SPECIFIED		PART NO. SEE TABLE		 Lian Xin Technology			
X ± 0.35	X° ± 3°	APPROVED BY Barney					TITLE MINI PCI EXPRESS 6.7H 0.8PITCH 52P
.XX ± 0.25	X° ± 2°	CHECKED BY Vito		DWG NO. AP-AAA-PCI-073			
.XXX ± 0.15	XX° ± 1°	DRAWN BY XU			SHEET	SCALE	REV
A4	MM				2 / 5	5 : 2	3

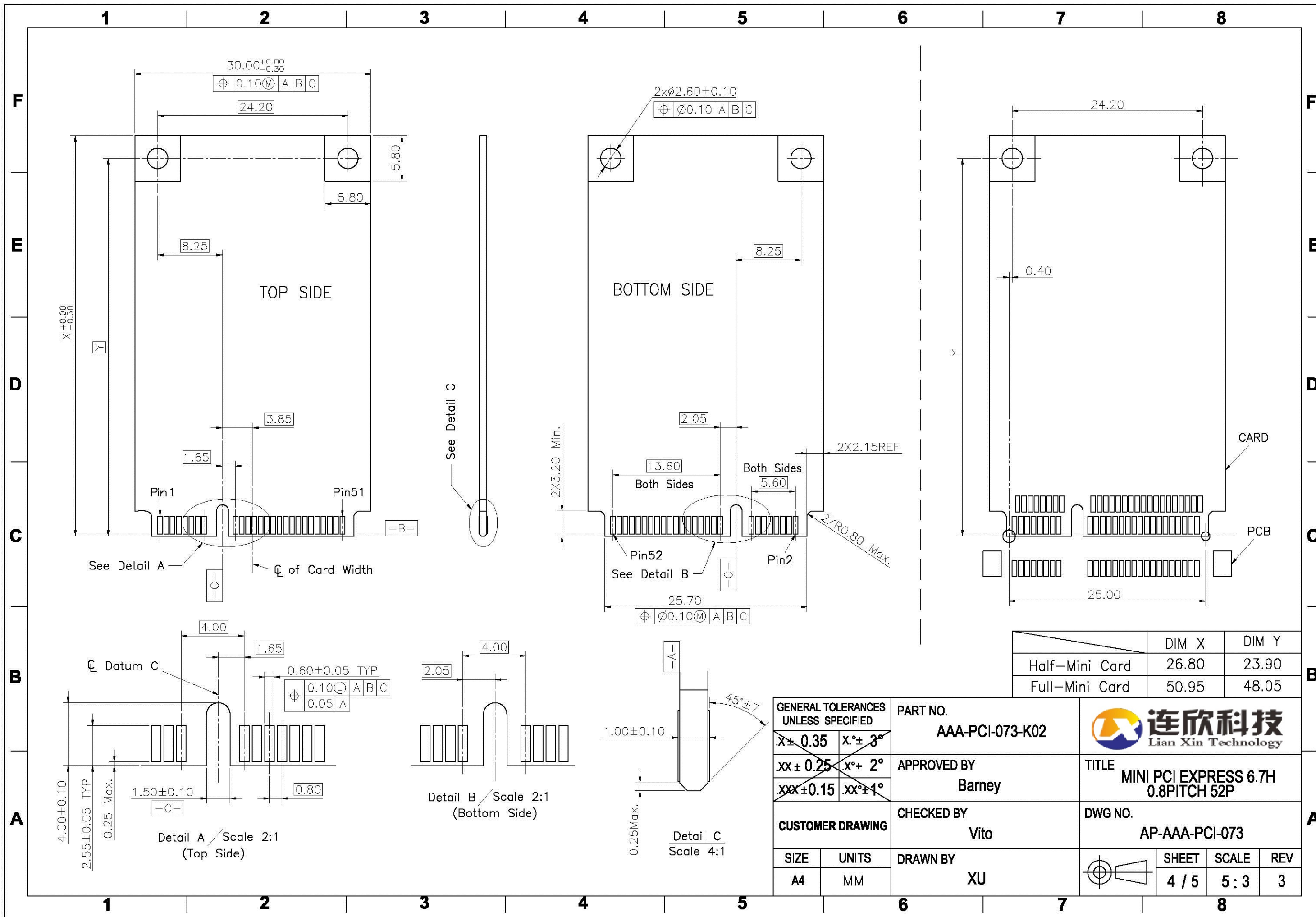

	DIM X	DIM Y
Half-Mini Card	26.80	23.90
Full-Mini Card	50.95	48.05

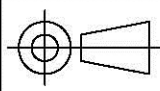
GENERAL TOLERANCES UNLESS SPECIFIED X ± 0.35 X° ± 3° XX ± 0.25 XX° ± 2° XXX ± 0.15 XXX° ± 1°		PART NO. AAA-PCI-073-K02	 连欣科技 Lian Xin Technology						
CUSTOMER DRAWING		APPROVED BY Barney		TITLE MINI PCI EXPRESS 6.7H 0.8PITCH 52P					
SIZE A4 UNITS MM		CHECKED BY Vito	DWG NO. AP-AAA-PCI-073						
DRAWN BY XU			<table border="1"> <tr> <th>SHEET</th> <th>SCALE</th> <th>REV</th> </tr> <tr> <td>4 / 5</td> <td>5 : 3</td> <td>3</td> </tr> </table>	SHEET	SCALE	REV	4 / 5	5 : 3	3
SHEET	SCALE	REV							
4 / 5	5 : 3	3							

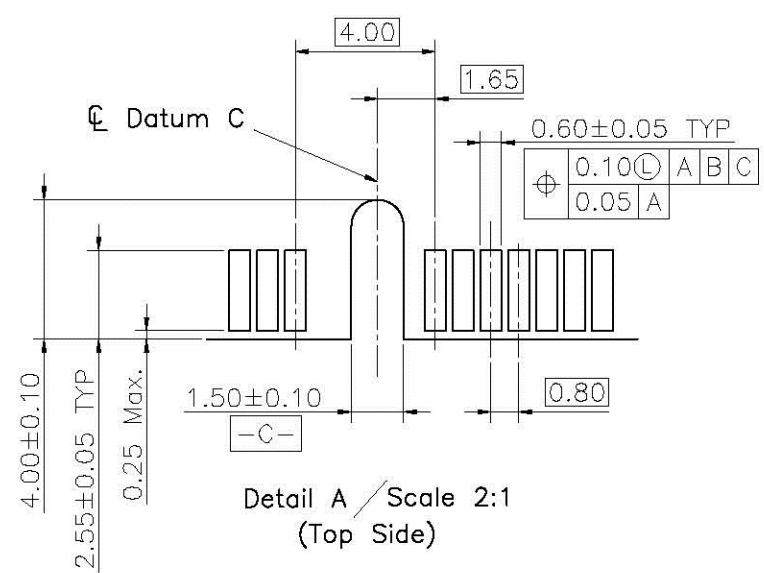
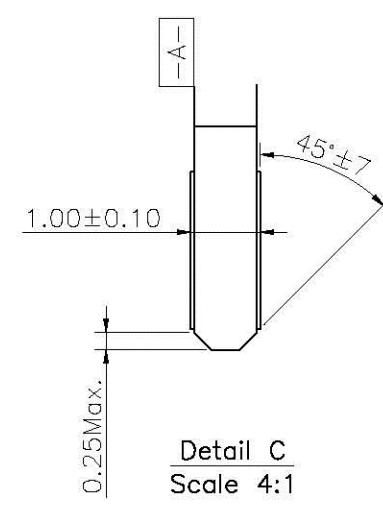
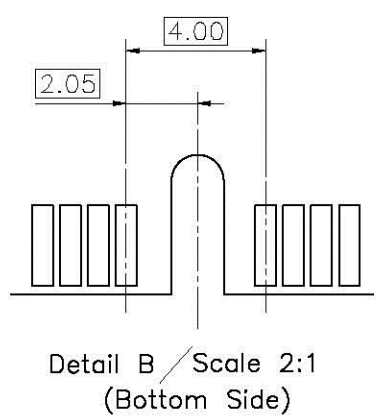

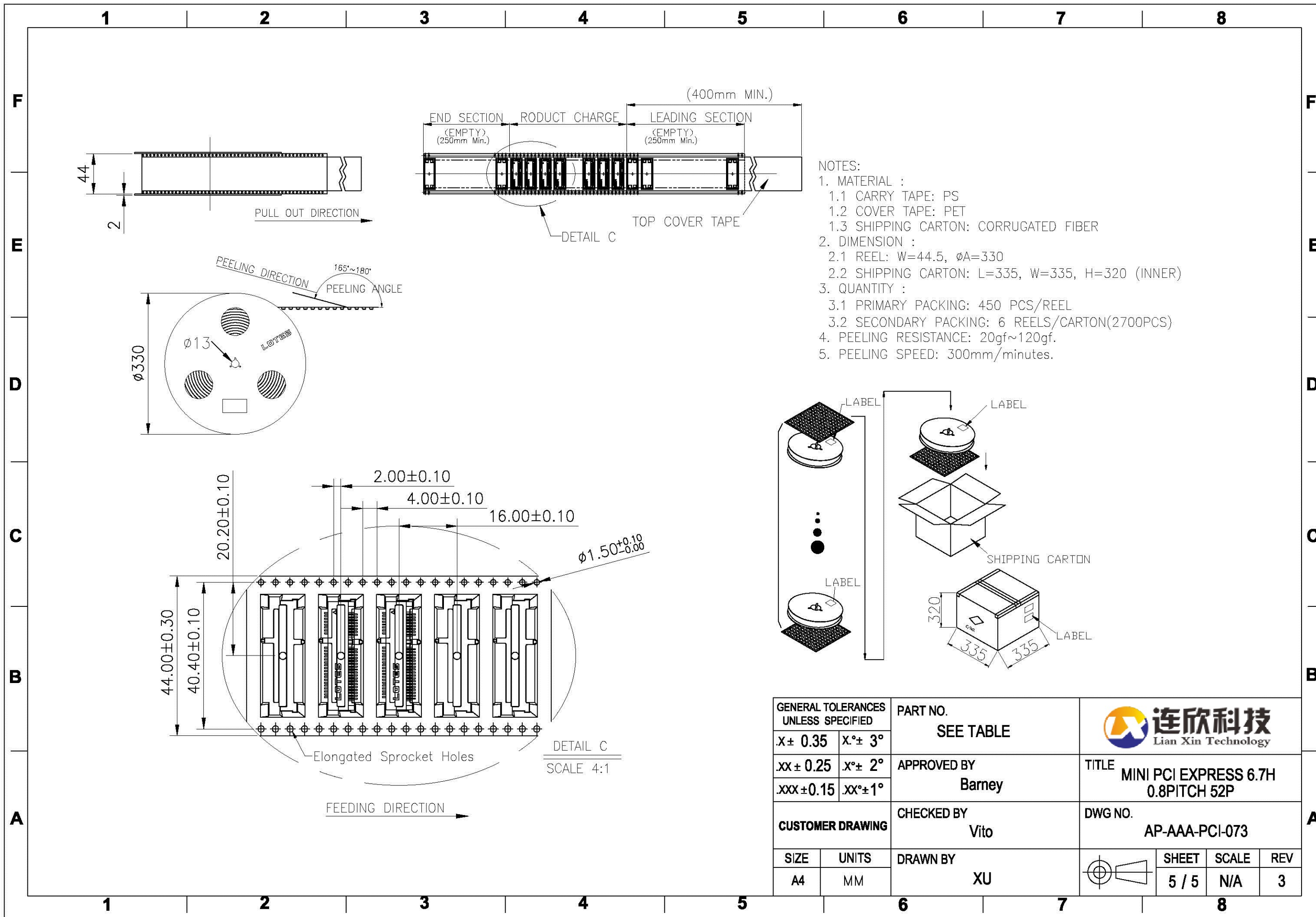

- NOTES:
- MATERIAL :
 - CARRY TAPE: PS
 - COVER TAPE: PET
 - SHIPPING CARTON: CORRUGATED FIBER
 - DIMENSION :
 - REEL: W=44.5, $\phi A=330$
 - SHIPPING CARTON: L=335, W=335, H=320 (INNER)
 - QUANTITY :
 - PRIMARY PACKING: 450 PCS/REEL
 - SECONDARY PACKING: 6 REELS/CARTON(2700PCS)
 - PEELING RESISTANCE: 20gf~120gf.
 - PEELING SPEED: 300mm/minutes.

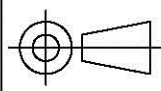
GENERAL TOLERANCES UNLESS SPECIFIED		PART NO. SEE TABLE	 连欣科技 Lian Xin Technology			
.X ± 0.35	X° ± 3°					
.XX ± 0.25	X° ± 2°	APPROVED BY Barney	TITLE MINI PCI EXPRESS 6.7H 0.8PITCH 52P			
.XXX ± 0.15	XX° ± 1°	CHECKED BY Vito	DWG NO. AP-AAA-PCI-073			
CUSTOMER DRAWING		DRAWN BY XU		SHEET	SCALE	REV
SIZE A4	UNITS MM			5 / 5	N/A	3

PRODUCT SPECIFICATION

REV

ECR No.

4C

SN14***

DIMENSION

- 1.This specification covers 0.8mm pitch MINI PCI EXPRESS(**AAA-PCI-073/092/093-*****) connector series.
- 2.The physical dimensions and the 0.8mm pitch MINI PCI EXPRESS connector are shown in drawing.

MATERIAL AND FINISH

- 1.Housing: High temperature thermoplastic.
- 2.Contact: Copper Alloy, Nickel-plating over all, Gold Plating on contact area, Matte Tin plated on solder area.
- 3.PEG : Copper Alloy , Matte Tin plated on solder area.

OPERATING PERFORMANCE

- 1.Operation Temperature: -55°C to 85°C
- 2.Voltage Rating: 25 V AC per contact
- 3.Current Rating: 0.5 A

ELECTRICAL PERFORMANCE

Test item	Test condition	Requirements
Examination of product	<ul style="list-style-type: none">• Visual inspection• EIA-364-18	<ul style="list-style-type: none">• No physical damage
Low Level Contact Resistance	<ul style="list-style-type: none">• Mate connectors: apply a current of 10mA(max) at open circuit voltage of 20mV (max) EIA-364-23	<ul style="list-style-type: none">• 55mΩ MAX. per contact (Initial)• ΔLLCR=20mΩ Max. (Final)
Insulation resistance	<ul style="list-style-type: none">• Applying 500VDC between adjacent contacts of unmated and unmount connectors EIA-364-21	<ul style="list-style-type: none">• 500MΩ MIN
Dielectric withstanding voltage	<ul style="list-style-type: none">• Measured by applying 300VAC for one minute between adjacent contacts of unmated connector assemblies. EIA-364-20	<ul style="list-style-type: none">• No breakdown or flash• Current leakage:1mA



PRODUCT NAME:

0.8mm PITCH MINI PCI EXPRESS CONNECTOR

DOCUMENT No:

SP-AAA-PCI-073

REV:

4C

PAGE:

1 OF 4

APPROVED BY:

Barney 03/30'14

CHECKED BY:

Vito 03/30'14

WRITTEN BY:

Lxh 03/30'14

PRODUCT SPECIFICATION

REV

ECR No.

4C

SN14***

MECHANICAL PERFORMANCE

Test item	Test condition	Requirements
Vibration test (Random)	<ul style="list-style-type: none">Subject mated connectors and vibrate per EIA 364-28 test Condition. VII test condition letter D(15 minutes in each of 3 mutually perpendicular directions)	<ul style="list-style-type: none">No electrical discontinuity greater than 1 microsecond.ΔLLCR =20mΩ Max.(Final)
Mechanical shock	<ul style="list-style-type: none">Subject mated connector to 50Gs, half-sine shock pulses of 11 millisecond duration, 3 drops in each direction applied along the 3 mutually perpendicular planes total 18 shock.EIA-364-27 test condition A	<ul style="list-style-type: none">No electrical discontinuity greater than 1 microsecondΔLLCR =20mΩ Max.(Final)No physical damage
Durability (repeated mate/un-mate)	<ul style="list-style-type: none">Repeat insertion the card to the connector and extraction card from the connector for 50 cycles.EIA-364-09	<ul style="list-style-type: none">ΔLLCR =20mΩ Max.(Final)
Mating and Unmating force	<ul style="list-style-type: none">Insert the card at the specified angleRotate the card into positionReverse the installation sequence to unmatingEIA-364-13	<ul style="list-style-type: none">2.3 Kgf MAX



TITLE:

0.8mm PITCH MINI PCI EXPRESS CONNECTOR

DOCUMENT No:

SP-AAA-PCI-073

REV:

4C

PAGE:

2 OF 4

APPROVED BY:

Barney 03/30'14

CHECKED BY:

Vito 03/30'14

WRITTEN BY:

Lxh 03/30'14

ENVIRONMENTAL PERFORMANCE

PRODUCT SPECIFICATION		REV	ECR No.
		4C	SN14***
Test item	Test condition	Requirements	
Humidity (steady state)	<ul style="list-style-type: none"> Expose the mates connectors to 40±2°C, relative humidity 90~95%RH for 96 hours. EIA-364-31 	<ul style="list-style-type: none"> △LLCR =20mΩ Max.(Final) Insulation resistance:500MΩMin. No physical damage. 	
Thermal shock	<ul style="list-style-type: none"> Expose the connectors to -55°C/30min. and 85°C/30min.(Repeat 10 cycles)---EIA-364-32 condition I 	<ul style="list-style-type: none"> △LLCR =20mΩ Max.(Final) No physical damage. 	
Solder ability	Solder temperature:245±5°C Immersion Duration:3±0.5sec.	<ul style="list-style-type: none"> Wet solder coverage: 95%Min 	
Salt spray	<ul style="list-style-type: none"> Subject the connector to 5%salt-solution concentration at 35°C for 24 hours. EIA-364-26 	<ul style="list-style-type: none"> △LLCR =20mΩMax .(Final) 	
Resistance to Solder Heat	<ul style="list-style-type: none"> EIA -364-56C IR Reflow : The peak temperature on the board shall be maintained for 10 second 260±5°C 	<ul style="list-style-type: none"> No evidence of physical damage 	
Rework temperature	Soldering iron method Soldering Time : 5 sec. Solder Temperature : 370-400°C <ul style="list-style-type: none"> 0.5 mm from terminal tip 	<ul style="list-style-type: none"> No evidence of physical damage 	
Temperature life	Mate PCB module and subject to 115±3°C for 240 hours EIA-364-17 condition A	<ul style="list-style-type: none"> Contact resistance: △LLCR =20mΩ Max.(Final) 	

TEST CONDITIONS

The tests shall be carried out under the conditions as the referring.

(1). Temperature:15~35°C .

(2). Humidity: 45~75%.

PACKAGE

All parts shall be packaged and packed to protect against physical damage, corrosion and deterioration during shipment and storage.

	TITLE:		
	0.8mm PITCH MINI PCI EXPRESS CONNECTOR		
	DOCUMENT No:	REV:	PAGE:
SP-AAA-PCI-073	4C	3 OF 4	
APPROVED BY:	CHECKED BY:	WRITTEN BY:	
Barney 03/30'14	Vito 03/30'14	Lxh 03/30'14	

PRODUCT SPECIFICATION

REV	ECR No.
4C	SN14***

TEST SEQUENCE:

Test or Examination	Test Group							
	A	B	C	D	E	F	G	H
Examination of Product	1,5	1,9	1,5	1,8	1,3	1,5	1,5	1,3
Contact Resistance	2,4	2,8	2,4			2,4	2,4	
Insulation Resistance				2,8				
Dielectric Withstanding Voltage				3,7				
Vibration	3							
Durability (Repeated)		5						
Mating force		3,7						
Unmating force		4,8						
Solder ability					2			
Humidity (Steady State)				5				
Thermal Shock				4				
Mechanical shock			3					
Temperature life						3		
Salt spray							3	
Resistance to Soldering Heat								2

RECOMMENDED INFRARED REFLOW CONDITION

Suggestion : In SMT process , the thickness of solder paste is 0.13mm minimum

▪ Infrared Reflow Condition

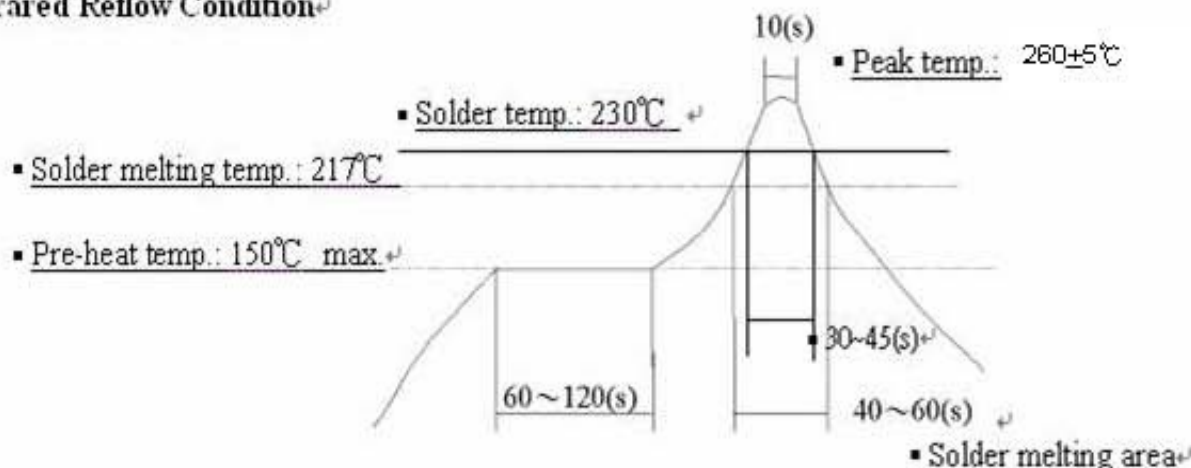

PRODUCT NAME:
0.8mm PITCH MINI PCI EXPRESS CONNECTOR

DOCUMENT No: SP-AAA-PCI-073	REV: 4C	PAGE: 4 OF 4
--------------------------------	------------	-----------------

APPROVED BY: Bamey 03/30'14	CHECKED BY: Vito 03/30'14	WRITTEN BY: Lxh 03/30'14
--------------------------------	------------------------------	-----------------------------

X-ON Electronics

Largest Supplier of Electrical and Electronic Components

Click to view similar products for [Standard Card Edge Connectors](#) category:

Click to view products by [Lian Xin](#) manufacturer:

Other Similar products are found below :

[CR7E-30DB-3.96E\(72\)](#) [6565204-6](#) [1437274-4](#) [1-582587-1](#) [284-0102-12100](#) [286-0052-12101A](#) [306022901000000](#) [A6D22DS29C2](#) [1926088-2](#) [245-062-520-350](#) [287-0032-12101](#) [306-028-525-102](#) [307-072-526-202](#) [330-030-500-278](#) [345-060-559-303](#) [534671-1](#) [341-240-317](#) [345-044-500-300](#) [346-240-318](#) [C7D10DS29C1M133](#) [395-100-524-300](#) [09-07-2032](#) [10035388-802LF](#) [10115859-011LF](#) [10122859-009LF](#) [101269333204245CLF](#) [530555-1](#) [66925-516LF](#) [5145409-2](#) [73726-0005](#) [66308-1](#) [EBC05DRXN](#) [KSLX-62-BR](#) [CE100F26-7-C](#) [CE100F28-3-D](#) [CE100F28-4-D](#) [CE156F22-9-C](#) [CT100F24-3-D](#) [CT100F24-6-C](#) [MLSS100-12-C](#) [SCC100F-11-C](#) [SCC100F-20-C](#) [SCC100F-24-C](#) [SCC100F-25-C](#) [3-530656](#) [2512250177](#) [285-0112-12300](#) [346-068-556-300](#) [284-0492-11000](#) [287-0032-12301](#)