

REV.	ECR/N NO./DESCRIPTION	DATE	DRAWN	CHECKED	APPROVE
1	SN14155	11/17'14	Lxh	Vito	Barney

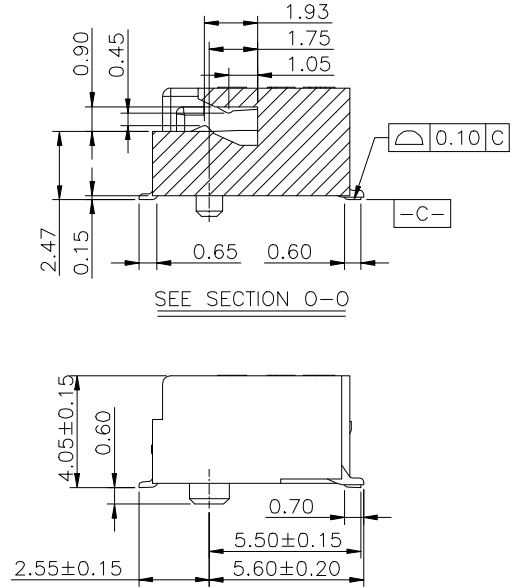

GENERAL TOLERANCES UNLESS SPECIFIED		PART NO.	 Lian Xin Technology
X± 0.35	X°± 3°	SEE TABLE	
XX± 0.25	X°± 2°	APPROVED BY	TITLE
XXX± 0.15	XX°± 1°	Barney 11/17'14	0.5 PITCH M.2 H4.2 (KEY E)
CUSTOMER DRAWING		CHECKED BY	DWG NO.
		Vito 11/17'14	AP-APCI0108
SIZE	UNITS	DRAWN BY	
A4	MM [INCH]	Lxh 11/17'14	
			SHEET
			1 / 5
			SCALE
			4:1
			REV
			1

TABLE:

NO.	PART NO.	DESCRIPTION	DURABILITY
1	APCI0108-P001A	GOLD G/F ON CONTACT AREA	25 CYCLES
		GOLD G/F ON SOLDER AREA	
2	APCI0108-P002A	GOLD 10u" ON CONTACT AREA	25 CYCLES
		GOLD G/F ON SOLDER AREA	
3	APCI0108-P003A	GOLD 15u" ON CONTACT AREA	25 CYCLES
		GOLD G/F ON SOLDER AREA	
4	APCI0108-P004A	GOLD 30u" ON CONTACT AREA	60 CYCLES
		GOLD G/F ON SOLDER AREA	
5	APCI0108-P005A	GOLD G/F ON CONTACT AREA	25 CYCLES
		80u" MIN. MATTE TIN ON SOLDER AREA	
6	APCI0108-P006A	GOLD 10u" ON CONTACT AREA	25 CYCLES
		80u" MIN. MATTE TIN ON SOLDER AREA	
7	APCI0108-P007A	GOLD 15u" ON CONTACT AREA	25 CYCLES
		80u" MIN. MATTE TIN ON SOLDER AREA	
8	APCI0108-P008A	GOLD 30u" ON CONTACT AREA	60 CYCLES
		80u" MIN. MATTE TIN ON SOLDER AREA	

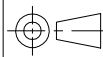

Notes:

- MATERIAL SPECIFICATION:
  - HOUSING:LCP+40%GF,UL94V-0,COLOR:BLACK.
  - CONTACT:COPPER ALLOY.
  - PEG:STEEL.
- PLATING SPECIFICATION:
  - CONTACT:50u" MIN.NICKEL UNDER PLATING OVER ALL.PLATING ON SOLDER AREA:SEE TABLE GOLD PLATING ON CONTACT AREA:SEE TABLE
  - PEG:50u" MIN. NICKEL UNDER PLATING OVER ALL. 80u" MIN. MATTE TIN PLATING ON SOLDER AREA.
- HF COMPLIANT, RoHS COMPLIANT.
- DATE CODE: XX XX XX  
 DAY  
 WEEK  
 YEAR
- MECHANICAL PERFORMANCE:
  - DURABILITY: SEE TABLE
- ELECTRICAL PERFORMANCE:
  - CURRENT: 0.5A PER PIN.
  - LLCR: INITIAL 55mΩ MAX.;FINAL ΔLLCR=20mΩ MAX.
- IR REFLOW:  
 THE TEMPERATURE SHALL BE 260±5°C MAINTAINING 10±1 SECONDS.
- PRODUCT NUMBER NOTE:

APCI0108-P001A - 0000000000

FINISHED PRODUCT

- CUSTOMER CODE
- PACKING TYPE
- PRODUCT SERIAL NUMBER
- P:HF COMPLIANT
- TYPE SERIAL NUMBER
- PRODUCT TYPE

GENERAL TOLERANCES UNLESS SPECIFIED		PART NO.	 连欣科技 Lian Xin Technology			
X ± 0.35	X ± 3°	SEE TABLE				
XX ± 0.25	X ± 2°	APPROVED BY	TITLE			
XXX ± 0.15	XX ± 1°	Bamey 11/17'14	0.5 PITCH M.2 H4.2 (KEY E)			
CUSTOMER DRAWING		CHECKED BY	DWG NO.			
		Vito 11/17'14	AP-APCI0108			
SIZE	UNITS	DRAWN BY		SHEET	SCALE	REV
A4	MM [INCH]	Lxh 11/17'14		2 / 5	4:1	1

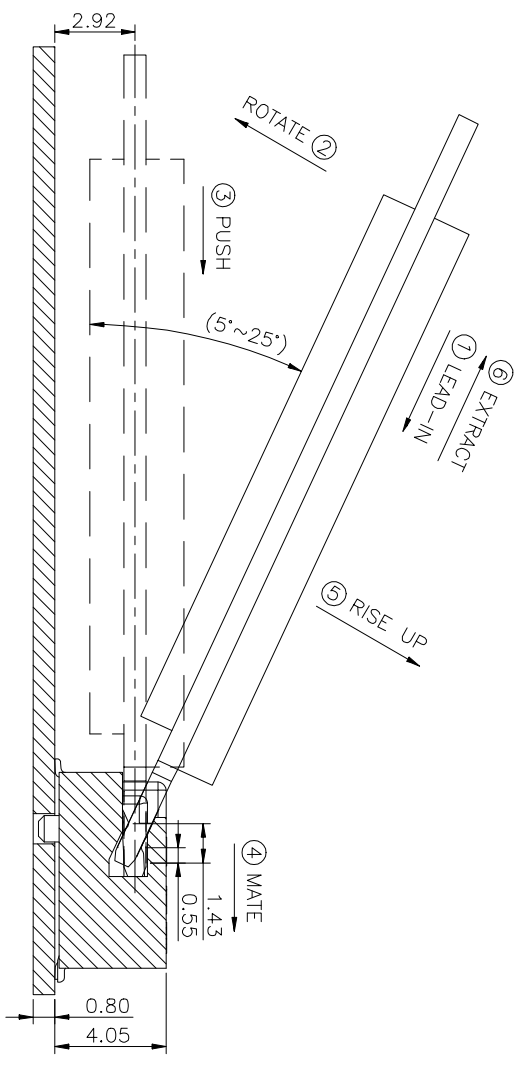
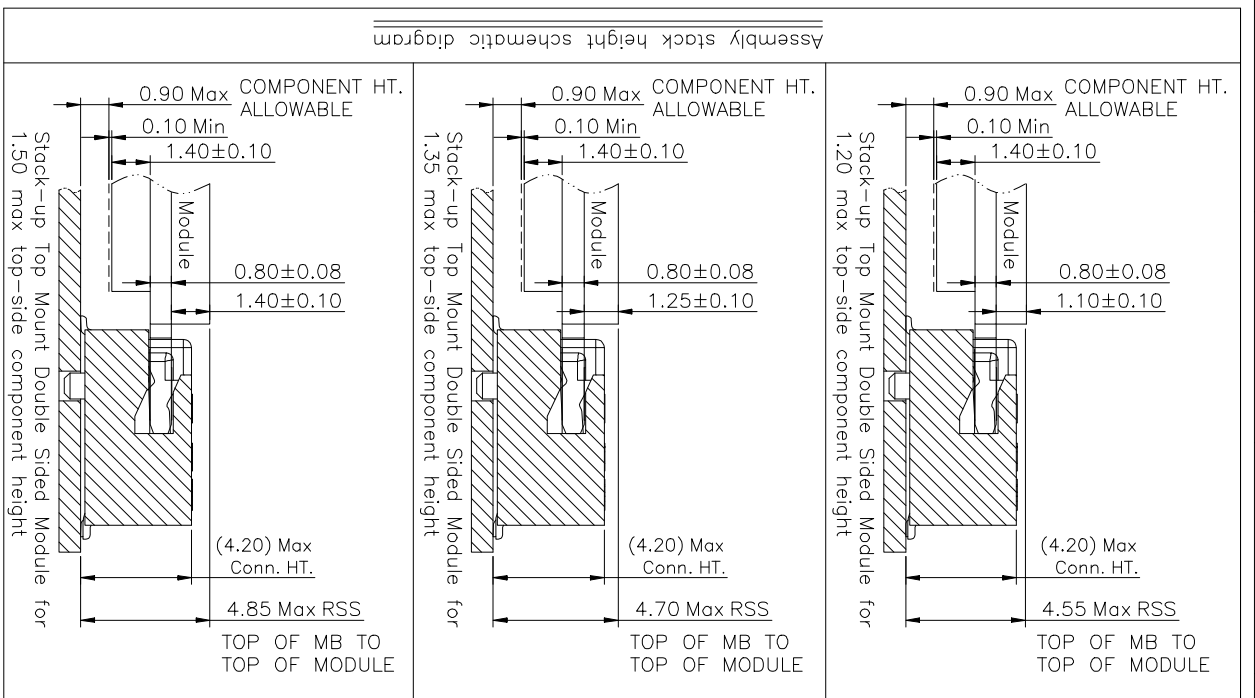

HOW TO MATE AND EXTRACT

MATE: ① → ④

EXTRACT: ⑤ → ②

NOTE: Mating force will generate from step 3 to step 4.

GENERAL TOLERANCES UNLESS SPECIFIED		PART NO.		
X ± 0.36	X ± 0.25	SEE TABLE		
XX ± 0.16	XX ± 0.10	APPROVED BY	TITLE	
XXX ± 0.10	XXX ± 0.05	Barney	0.5 PITCH M.2 H4.2 (KEY E)	
CUSTOMER DRAWING		CHECKED BY	DWG NO.	
		Vllo	AP-APC10108	
SIZE	UNITS	DRAWN BY		SHEET
A4	MM [INCH]	Ljh	11/17/14	3 / 5
				SCALE
				4:1
				REV
				1

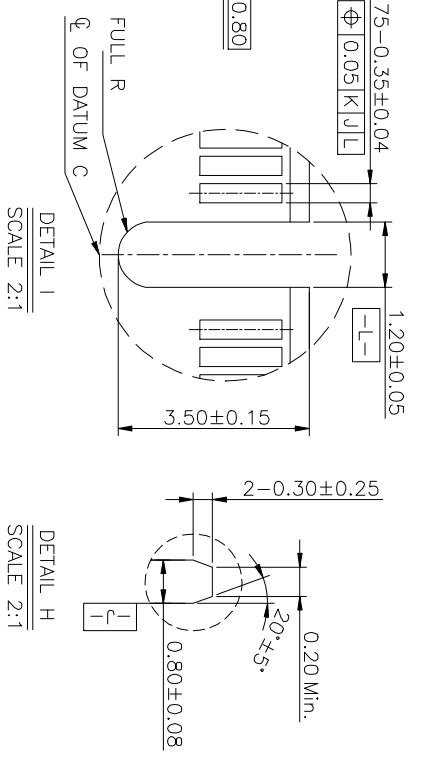
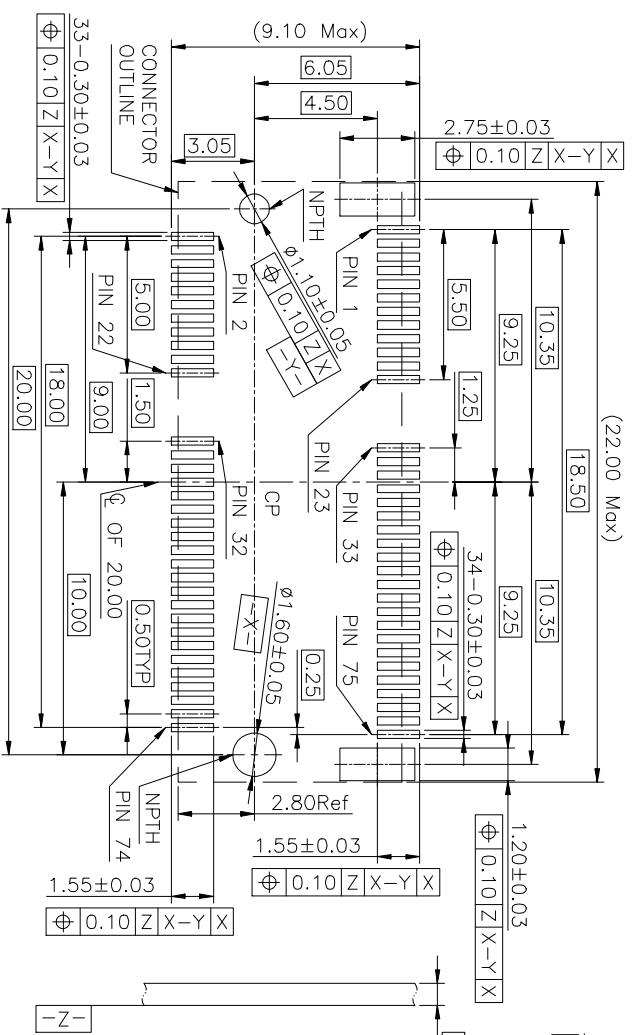
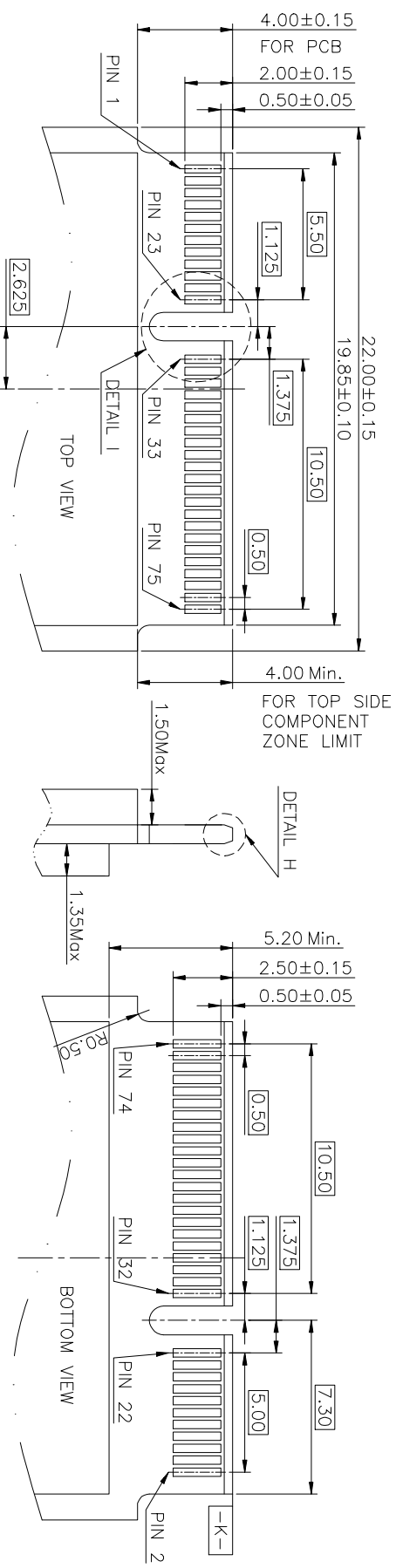

GENERAL TOLERANCES UNLESS SPECIFIED		PART NO.		TITLE	
X±	0.25	X±	2	SEE TABLE	0.5 PITCH M.2 H4.2 (KEY E)
XX±	0.15	XX±	1	APPROVED BY	
XXX±	0.15	XXX±	1	Bartney	11/17/14
CUSTOMER DRAWING		CHECKED BY		DWG NO.	
Vito		11/17/14		AP-APC10108	
SIZE	UNITS	DRAWN BY		SHEET	SCALE
A4	MM[INCH]	Ljh	11/17/14	4 / 5	4:1
				REV	1



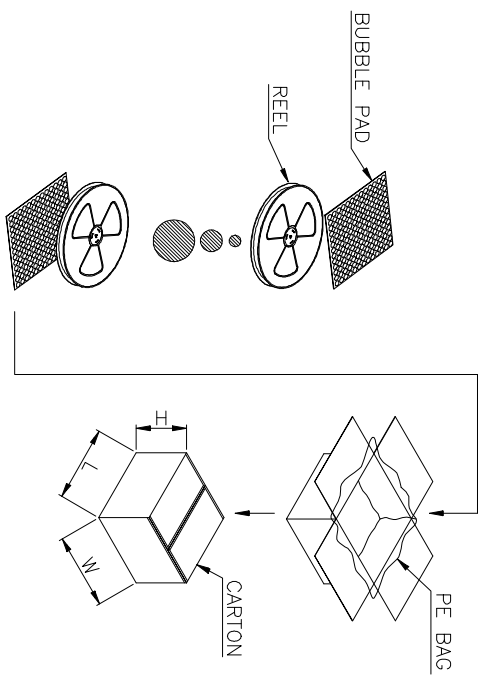
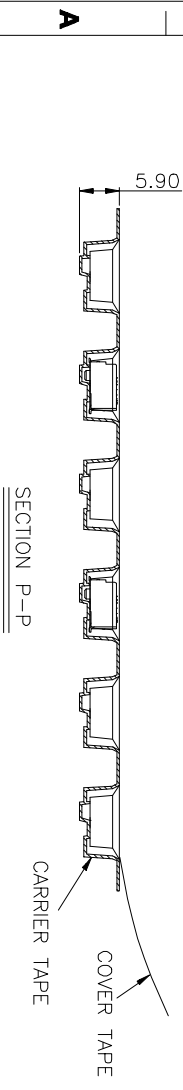
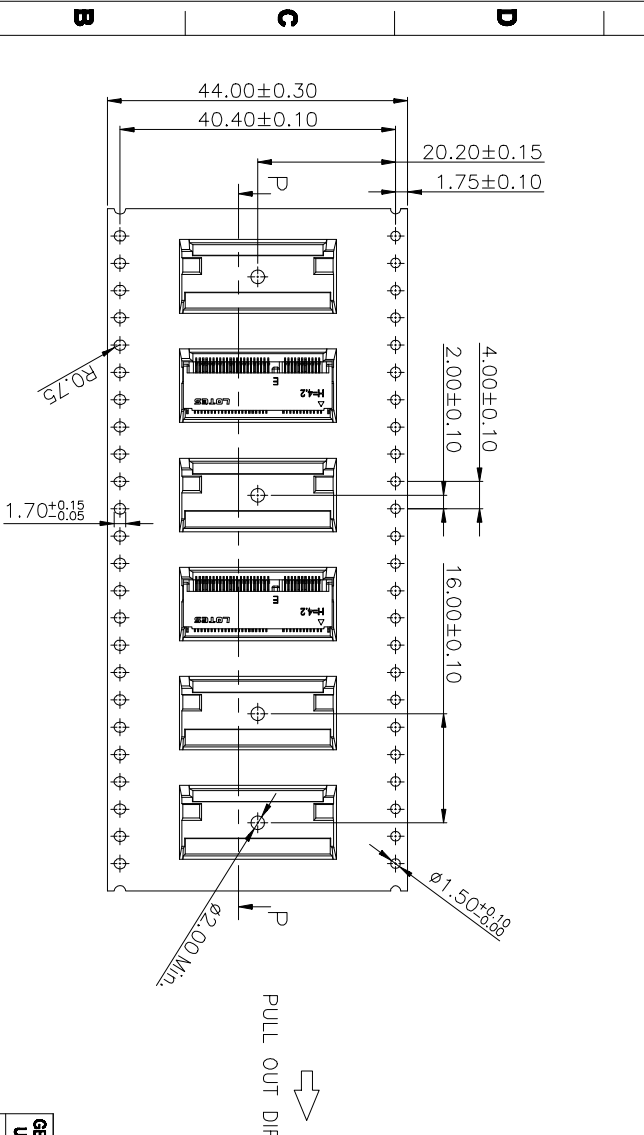
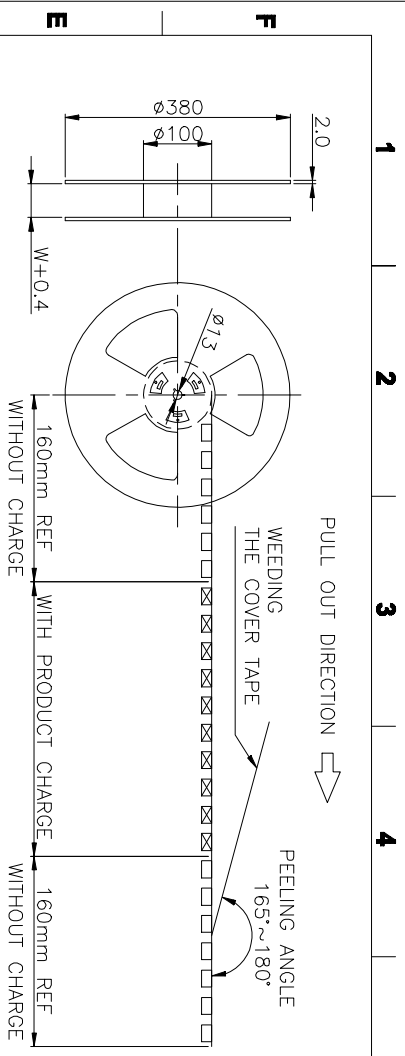

GENERAL TOLERANCES UNLESS SPECIFIED		PART NO. SEE TABLE		TITLE	
X ± 0.35	X ± 2°	APPROVED BY		0.5 PITCH M.2 H4.2 (KEY E)	
XX ± 0.25	X ± 2°	Barney		11/17/14	
XXX ± 0.15	.XX ± 1°	CHECKED BY		DWG NO.	
CUSTOMER DRAWING		Vib		AP-APCI0108	
SIZE	UNITS	DRAWN BY	Lxh	11/17/14	
A4	MM [INCH]				
PCS/REEL		PCS/CARTON		SHEET SCALE REV	
900		5400		5 / 5 1:1 1	



## X-ON Electronics

Largest Supplier of Electrical and Electronic Components

*Click to view similar products for [Standard Card Edge Connectors](#) category:*

*Click to view products by [Lian Xin](#) manufacturer:*

Other Similar products are found below :

[CR7E-30DB-3.96E\(72\)](#) [6565204-6](#) [1437274-4](#) [1-582587-1](#) [284-0102-12100](#) [286-0052-12101A](#) [306022901000000](#) [A6D22DS29C2](#) [1926088-2](#) [245-062-520-350](#) [287-0032-12101](#) [306-028-525-102](#) [307-072-526-202](#) [330-030-500-278](#) [345-060-559-303](#) [534671-1](#) [341-240-317](#) [345-044-500-300](#) [346-240-318](#) [C7D10DS29C1M133](#) [395-100-524-300](#) [09-07-2032](#) [10035388-802LF](#) [10115859-011LF](#) [10122859-009LF](#) [101269333204245CLF](#) [530555-1](#) [66925-516LF](#) [5145409-2](#) [73726-0005](#) [66308-1](#) [EBC05DRXN](#) [KSLX-62-BR](#) [CE100F26-7-C](#) [CE100F28-3-D](#) [CE100F28-4-D](#) [CE156F22-9-C](#) [CT100F24-3-D](#) [CT100F24-6-C](#) [MLSS100-12-C](#) [SCC100F-11-C](#) [SCC100F-20-C](#) [SCC100F-24-C](#) [SCC100F-25-C](#) [3-530656](#) [2512250177](#) [285-0112-12300](#) [346-068-556-300](#) [284-0492-11000](#) [287-0032-12301](#)