

Dual Micropower DC/DC Converter with Positive and Negative Outputs

FEATURES

- Generates Well-Regulated Positive and Negative Outputs
- Low Quiescent Current:
 20 μ A in Active Mode (per Converter)
 <1 μ A in Shutdown Mode
- Operates with V_{IN} as Low as 1.2V
- Low V_{CESAT} Switch: 250mV at 300mA
- Uses Small Surface Mount Components
- High Output Voltage: Up to \pm 34V
- Tiny 10-Pin MSOP Package

APPLICATIONS

- Small TFT LCD Panels
- Handheld Computers
- Battery Backup
- Digital Cameras

DESCRIPTION

The LT[®]1945 is a dual micropower DC/DC converter in a 10-pin MSOP package. Each converter is designed with a 350mA current limit and an input voltage range of 1.2V to 15V, making the LT1945 ideal for a wide variety of applications. Both converters feature a quiescent current of only 20 μ A at no load, which further reduces to 0.5 μ A in shutdown. A current limited, fixed off-time control scheme conserves operating current, resulting in high efficiency over a broad range of load current. The 36V switch allows high voltage outputs up to \pm 34V to be easily generated without the use of costly transformers. The LT1945's low off-time of 400ns permits the use of tiny, low profile inductors and capacitors to minimize footprint and cost in space-conscious portable applications.

LT, LT, LTC and LTM are registered trademarks of Linear Technology Corporation. All other trademarks are the property of their respective owners.

TYPICAL APPLICATION

Dual Output (+12V, -20V) Converter

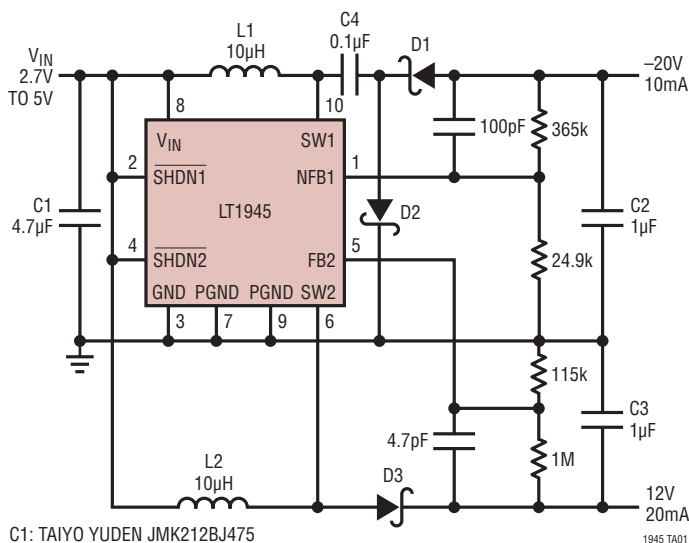

C1: TAIYO YUDEN JMK212BJ475
 C2, C3: TAIYO YUDEN TMK316BJ105
 C4: TAIYO YUDEN EMK107BJ104
 D1, D2, D3: ZETEX ZHCS400
 L1, L2: MURATA LQH3C100

Efficiency at $V_{IN} = 3.6V$

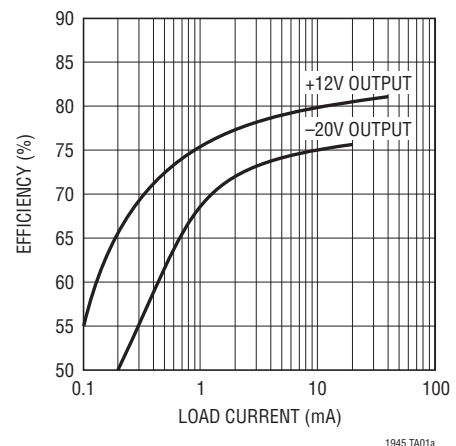

ABSOLUTE MAXIMUM RATINGS

(Note 1)

V_{IN} , $\overline{SHDN1}$, $\overline{SHDN2}$ Voltage.....	15V
SW1, SW2 Voltage.....	36V
NFB1 Voltage.....	-3V
FB2 Voltage.....	V_{IN}
Current into NFB1 Pin.....	-1mA
Current into FB2 Pin.....	1mA
Junction Temperature.....	125°C
Operating Temperature Range (Note 2)....	-40°C to 85°C
Storage Temperature Range.....	-65°C to 150°C
Lead Temperature (Soldering, 10 sec).....	300°C

PIN CONFIGURATION

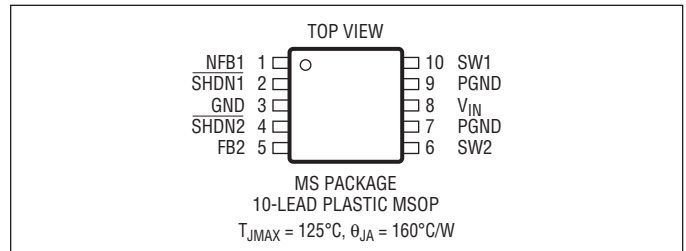

ORDER INFORMATION

LEAD FREE FINISH	TAPE AND REEL	PART MARKING*	PACKAGE DESCRIPTION	TEMPERATURE RANGE
LT1945EMS#PBF	LT1945EMS#TRPBF	LTTS	10-Lead Plastic MSOP	-40°C to 85°C
LT1945IMS#PBF	LT1945IMS#TRPBF	LTTS	10-Lead Plastic MSOP	-40°C to 125°C
LEAD BASED FINISH	TAPE AND REEL	PART MARKING*	PACKAGE DESCRIPTION	TEMPERATURE RANGE
LT1945EMS	LT1945EMS#TR	LTTS	10-Lead Plastic MSOP	-40°C to 85°C
LT1945IMS	LT1945IMS#TR	LTTS	10-Lead Plastic MSOP	-40°C to 125°C

Consult LTC Marketing for parts specified with wider operating temperature ranges. *The temperature grade is identified by a label on the shipping container.

For more information on lead free part marking, go to: <http://www.linear.com/leadfree/>

For more information on tape and reel specifications, go to: <http://www.linear.com/tapeandreel/>

ELECTRICAL CHARACTERISTICS

The ● denotes the specifications which apply over the full operating temperature range, otherwise specifications are at $T_A = 25^\circ\text{C}$. $V_{IN} = 1.2\text{V}$, $V_{\overline{SHDN}} = 1.2\text{V}$ unless otherwise noted.

PARAMETER	CONDITIONS	MIN	TYP	MAX	UNITS
Minimum Input Voltage				1.2	V
Quiescent Current, (per Converter)	Not Switching $V_{\overline{SHDN}} = 0\text{V}$		20	30 1	μA μA
NFB1 Comparator Trip Point	$-40^\circ\text{C} < T_J < 85^\circ\text{C}$ $-40^\circ\text{C} < T_J < 125^\circ\text{C}$	-1.205 -1.195	-1.23	-1.255 1.255	V V
FB2 Comparator Trip Point	$-40^\circ\text{C} < T_J < 85^\circ\text{C}$ $-40^\circ\text{C} < T_J < 125^\circ\text{C}$	1.205 1.195	1.23	1.255 1.255	V V
FB Comparator Hysteresis			8		mV
NFB1, FB2 Voltage Line Regulation	$1.2\text{V} < V_{IN} < 12\text{V}$		0.05	0.1	%/V
NFB1 Pin Bias Current (Note 3)	$V_{NFB1} = -1.23\text{V}$	● 1.3	2	2.9	μA
FB2 Pin Bias Current (Note 4)	$-40^\circ\text{C} < T_J < 85^\circ\text{C}$ $-40^\circ\text{C} < T_J < 125^\circ\text{C}$		30	80 300	nA nA
Switch Off Time, Switcher 1 (Note 5)			400		ns
Switch Off Time, Switcher 2 (Note 5)	$V_{FB2} > 1\text{V}$ $V_{FB2} < 0.6\text{V}$		400 1.5		ns μs
Switch V_{CESAT}	$I_{SW} = 300\text{mA}$		250	350	mV
Switch Current Limit		250	350	400	mA

1945fa

ELECTRICAL CHARACTERISTICS The ● denotes the specifications which apply over the full operating temperature range, otherwise specifications are at $T_A = 25^\circ\text{C}$. $V_{IN} = 1.2\text{V}$, $V_{SHDN} = 1.2\text{V}$ unless otherwise noted.

PARAMETER	CONDITIONS	MIN	TYP	MAX	UNITS
SHDN Pin Current	$V_{SHDN} = 1.2\text{V}$		2	3	μA
	$V_{SHDN} = 5\text{V}$		8	12	μA
SHDN Input Voltage High		0.9			V
SHDN Input Voltage Low				0.25	V
Switch Leakage Current	Switch Off, $V_{SW} = 5\text{V}$		0.01	5	μA

Note 1: Stresses beyond those listed under Absolute Maximum Ratings may cause permanent damage to the device. Exposure to any Absolute Maximum Rating condition for extended periods may affect device reliability and lifetime.

Note 2: The LT1945E is guaranteed to meet performance specifications from 0°C to 70°C junction temperature. Specifications over the -40°C to 85°C operating junction temperature range are assured by design,

characterization and correlation with statistical process controls. The LT1945I is guaranteed over the full -40°C to 125°C operating junction temperature range.

Note 3: Bias current flows out of the NFB1 pin.

Note 4: Bias current flows into the FB2 pin.

Note 5: See Figure 1 for Switcher 1 and Switcher 2 locations.

TYPICAL PERFORMANCE CHARACTERISTICS

Switch Saturation Voltage (VCESAT)

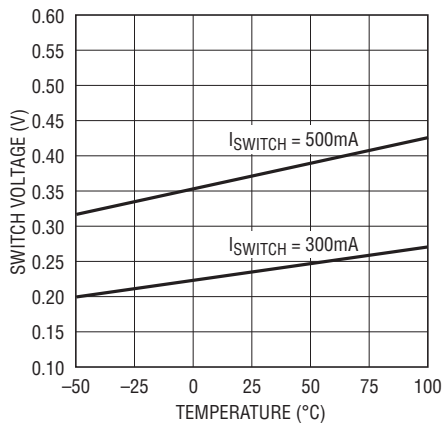

1945 G01

FB2 Pin Voltage and Bias Current

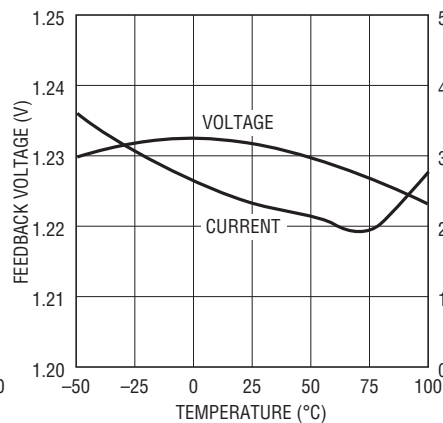

1945 G02

NFB1 Pin Voltage and Bias Current

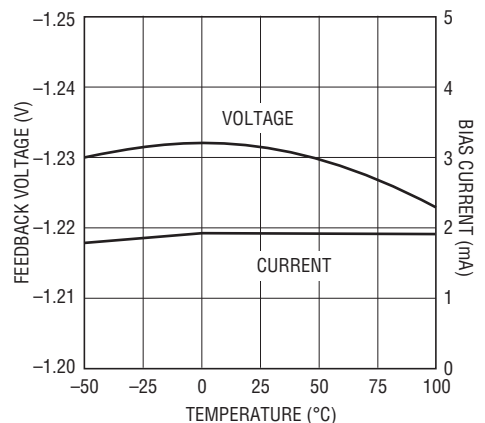

1945 G03

Switch Off Time

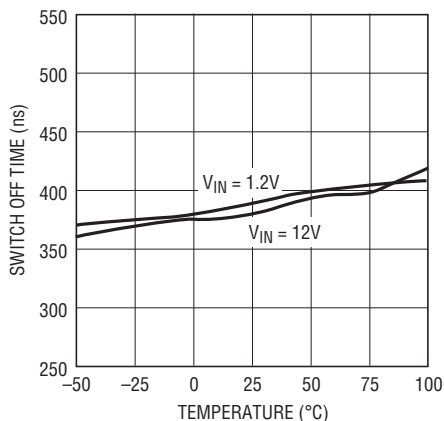

1945 G04

Switch Current Limit

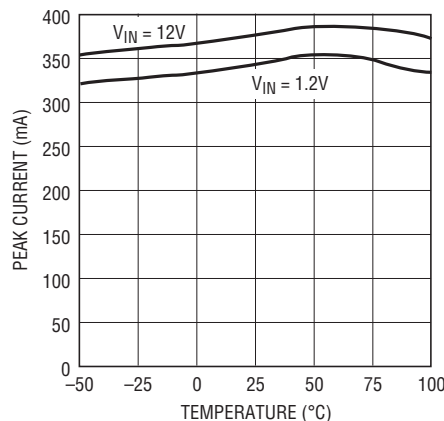

1945 G05

Quiescent Current

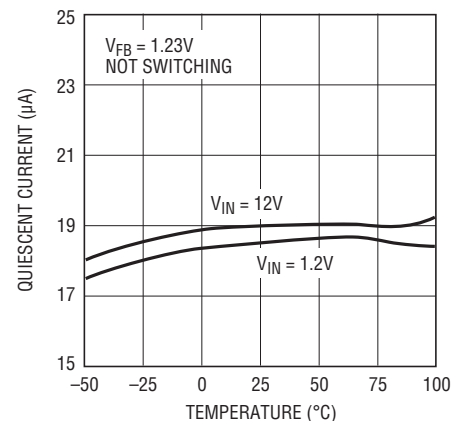

1945 G06
1945fa

PIN FUNCTIONS

NFB1 (Pin 1): Feedback Pin for Switcher 1. Set the output voltage by selecting values for R1 and R2.

SHDN1 (Pin 2): Shutdown Pin for Switcher 1. Tie this pin to 0.9V or higher to enable device. Tie below 0.25V to turn it off.

GND (Pin 3): Ground. Tie this pin directly to the local ground plane.

SHDN2 (Pin 4): Shutdown Pin for Switcher 2. Tie this pin to 0.9V or higher to enable device. Tie below 0.25V to turn it off.

FB2 (Pin 5): Feedback Pin for Switcher 2. Set the output voltage by selecting values for R1B and R2B.

SW2 (Pin 6): Switch Pin for Switcher 2. This is the collector of the internal NPN power switch. Minimize the metal trace area connected to the pin to minimize EMI.

PGND (Pins 7, 9): Power Ground. Tie these pins directly to the local ground plane. Both pins must be tied.

V_{IN} (Pin 8): Input Supply Pin. Bypass this pin with a capacitor as close to the device as possible.

SW1 (Pin 10): Switch Pin for Switcher 1. This is the collector of the internal NPN power switch. Minimize the metal trace area connected to the pin to minimize EMI.

BLOCK DIAGRAM

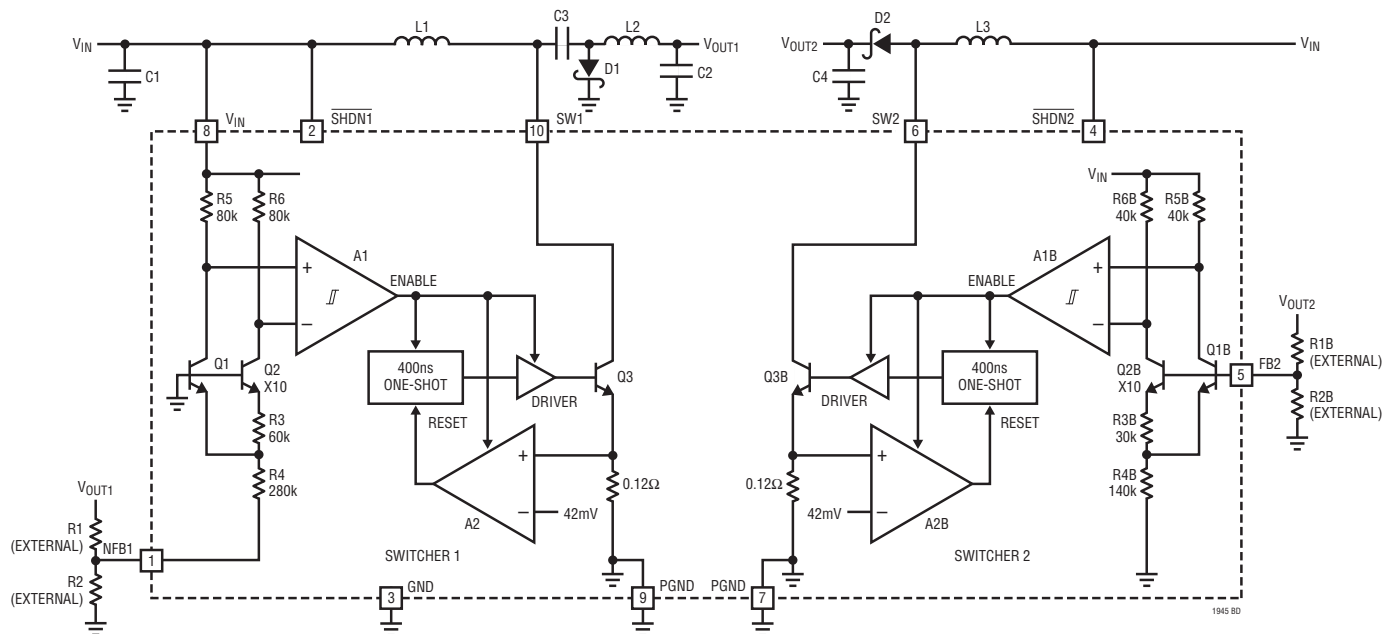

Figure 1. LT1945 Block Diagram

OPERATION

The LT1945 uses a constant off-time control scheme to provide high efficiencies over a wide range of output current. Operation can be best understood by referring to the block diagram in Figure 1. Q1 and Q2 along with R3 and R4 form a bandgap reference used to regulate the output voltage. When the voltage at the NFB1 pin is

slightly below -1.23V , comparator A1 disables most of the internal circuitry. Output current is then provided by capacitor C2, which slowly discharges until the voltage at the NFB1 pin goes above the hysteresis point of A1 (typical hysteresis at the NFB1 pin is 8mV). A1 then enables the internal circuitry, turns on power switch Q3, and the

1945fa

OPERATION

current in inductors L1 and L2 begins ramping up. Once the switch current reaches 350mA, comparator A2 resets the one-shot, which turns off Q3 for 400ns. L2 continues to deliver current to the output while Q3 is off. Q3 turns on again and the inductor currents ramp back up to 350mA, then A2 again resets the one-shot. This switching action continues until the output voltage is charged up (until the NFB1 pin reaches -1.23V), then A1 turns off the internal circuitry and the cycle repeats.

The second switching regulator is a step-up converter (which generates a positive output) but the basic operation is the same. The LT1945 contains additional circuitry to provide protection during start-up and under short-circuit conditions. When the FB2 pin voltage is less than approximately 600mV, the switch off-time is increased to 1.5µs and the current limit is reduced to around 250mA (70% of its normal value). This reduces the average inductor current and helps minimize the power dissipation in the power switch and in the external inductor and diode.

APPLICATIONS INFORMATION

Choosing an Inductor

Several recommended inductors that work well with the LT1945 are listed in Table 1, although there are many other manufacturers and devices that can be used. Consult each manufacturer for more detailed information and for their entire selection of related parts. Many different sizes and shapes are available. Use the equations and recommendations in the next few sections to find the correct inductance value for your design.

Table 1. Recommended Inductors

PART	VALUE (µH)	MAX DCR (Ω)	VENDOR
LQH3C4R7	4.7	0.26	Murata (714) 852-2001 www.murata.com
LQH3C100	10	0.30	
LQH3C220	22	0.92	
CD43-4R7	4.7	0.11	Sumida (847) 956-0666 www.sumida.com
CD43-100	10	0.18	
CDRH4D18-4R7	4.7	0.16	
CDRH4D18-100	10	0.20	
DO1608-472	4.7	0.09	Coilcraft (847) 639-6400 www.coilcraft.com
DO1608-103	10	0.16	
DO1608-223	22	0.37	

Inductor Selection—Boost Regulator

The formula below calculates the appropriate inductor value to be used for a boost regulator using the LT1945 (or at least provides a good starting point). This value provides a good tradeoff in inductor size and system performance. Pick a standard inductor close to this value. A larger value can be used to slightly increase the available output current, but limit it to around twice the value calculated below, as too large of an inductance will increase the output voltage ripple without providing much additional output current.

A smaller value can be used (especially for systems with output voltages greater than 12V) to give a smaller physical size. Inductance can be calculated as:

$$L = \frac{V_{OUT} - V_{IN(MIN)} + V_D}{I_{LIM}} t_{OFF}$$

where $V_D = 0.4V$ (Schottky diode voltage), $I_{LIM} = 350mA$ and $t_{OFF} = 400ns$; for designs with varying V_{IN} such as battery powered applications, use the minimum V_{IN} value in the above equation. For most regulators with output voltages below 7V, a 4.7µH inductor is the best choice, even though the equation above might specify a smaller value. This is due to the inductor current overshoot that occurs when very small inductor values are used (see Current Limit Overshoot section).

For higher output voltages, the formula above will give large inductance values. For a 2V to 20V converter (typical LCD Bias application), a 21µH inductor is called for with the above equation, but a 10µH inductor could be used without excessive reduction in maximum output current.

Inductor Selection—SEPIC Regulator

The formula below calculates the approximate inductor value to be used for a SEPIC regulator using the LT1945. As for the boost inductor selection, a larger or smaller value can be used.

$$L = 2 \left(\frac{V_{OUT} + V_D}{I_{LIM}} \right) t_{OFF}$$

APPLICATIONS INFORMATION

Inductor Selection—Inverting Regulator

The formula below calculates the appropriate inductor value to be used for an inverting regulator using the LT1945 (or at least provides a good starting point). This value provides a good tradeoff in inductor size and system performance. Pick a standard inductor close to this value (both inductors should be the same value). A larger value can be used to slightly increase the available output current, but limit it to around twice the value calculated below, as too large of an inductance will increase the output voltage ripple without providing much additional output current. A smaller value can be used (especially for systems with output voltages greater than 12V) to give a smaller physical size. Inductance can be calculated as:

$$L = 2 \left(\frac{|V_{OUT}| + V_D}{I_{LIM}} \right) t_{OFF}$$

where $V_D = 0.4V$ (Schottky diode voltage), $I_{LIM} = 350mA$ and $t_{OFF} = 400ns$.

For higher output voltages, the formula above will give large inductance values. For a 2V to 20V converter (typical LCD bias application), a 47 μH inductor is called for with the above equation, but a 10 μH or 22 μH inductor could be used without excessive reduction in maximum output current.

Inductor Selection—Inverting Charge Pump Regulator

For the inverting regulator, the voltage seen by the internal power switch is equal to the sum of the absolute value of the input and output voltages, so that generating high output voltages from a high input voltage source will often exceed the 36V maximum switch rating. For instance, a 12V to -30V converter using the inverting topology would generate 42V on the SW pin, exceeding its maximum rating. For this application, an inverting charge pump is the best topology.

The formula below calculates the approximate inductor value to be used for an inverting charge pump regulator using the LT1945. As for the boost inductor selection, a larger or smaller value can be used. For designs with varying V_{IN} such as battery powered applications, use the minimum V_{IN} value in the equation below.

$$L = \frac{|V_{OUT}| - V_{IN(MIN)} + V_D}{I_{LIM}} t_{OFF}$$

Current Limit Overshoot

For the constant off-time control scheme of the LT1945, the power switch is turned off only after the 350mA current limit is reached. There is a 100ns delay between the time when the current limit is reached and when the switch actually turns off. During this delay, the inductor current exceeds the current limit by a small amount. The peak inductor current can be calculated by:

$$I_{PEAK} = I_{LIM} + \left(\frac{V_{IN(MAX)} - V_{SAT}}{L} \right) 100ns$$

Where $V_{SAT} = 0.25V$ (switch saturation voltage). The current overshoot will be most evident for regulators with high input voltages and smaller inductor values. This overshoot can be beneficial as it helps increase the amount of available output current for smaller inductor values. This will be the peak current seen by the inductor (and the diode) during normal operation. For designs using small inductance values (especially at input voltages greater than 5V), the current limit overshoot can be quite high. Although it is internally current limited to 350mA, the power switch of the LT1945 can handle larger currents without problem, but the overall efficiency will suffer. Best results will be obtained when I_{PEAK} is kept below 700mA for the LT1945.

Capacitor Selection

Low ESR (Equivalent Series Resistance) capacitors should be used at the output to minimize the output ripple voltage. X5R or X7R multilayer ceramic capacitors are the best choice, as they have a very low ESR and are available in very small packages. Y5V ceramics are not recommended. Their small size makes them a good companion to the LT1945's MS10 package. Solid tantalum capacitors (like the AVX TPS, Sprague 593D families) or OS-CON capacitors can be used, but they will occupy more board area than a ceramic and will have a higher ESR. Always use a capacitor with a sufficient voltage rating.

Ceramic capacitors also make a good choice for the input decoupling capacitor, which should be placed as close as possible to the LT1945. A 4.7 μF input capacitor is sufficient for most applications. Table 2 shows a list of several capacitor manufacturers. Consult the manufacturers for more detailed information and for their entire selection

APPLICATIONS INFORMATION

of related parts.

Table 2. Recommended Capacitors

CAPACITOR TYPE	VENDOR
Ceramic	Taiyo Yuden (408) 573-4150 www.t-yuden.com
Ceramic	AVX (803) 448-9411 www.avxcorp.com
Ceramic	Murata (714) 852-2001 www.murata.com

Setting the Output Voltages

Set the output voltage for Switcher 1 (negative output voltage) by choosing the appropriate values for feedback resistors R1 and R2.

$$R1 = \frac{|V_{OUT}| - 1.23V}{\frac{1.23V}{R2} + (2 \cdot 10^{-6})}$$

Set the output voltage for Switcher 2 (positive output voltage) by choosing the appropriate values for feedback resistors R1B and R2B (see Figure 1).

$$R1 = R2 \left(\frac{V_{OUT}}{1.23} - 1 \right)$$

Diode Selection

For most LT1945 applications, the Zetex ZHCS400 surface mount Schottky diode (0.4A, 40V) is an ideal choice. Schottky diodes, with their low forward voltage drop and fast switching speed, are the best match for the LT1945. The Motorola MBR0520, MBR0530, or MBR0540 can also be used. Many different manufacturers make equivalent parts, but make sure that the component is rated to handle at least 0.35A.

Lowering Output Voltage Ripple

Using low ESR capacitors will help minimize the output ripple voltage, but proper selection of the inductor and the output capacitor also plays a big role. The LT1945 provides energy to the load in bursts by ramping up the inductor current, then delivering that current to the load. If too large of an inductor value or too small of a capacitor value is used, the output ripple voltage will increase because the capacitor will be slightly overcharged each burst cycle. To reduce the output ripple, increase the output capacitor value or add a 4.7pF feed-forward capacitor in the feedback network of the LT1945 (see the circuits in the Typical Applications section). Adding this small, inexpensive 4.7pF capacitor will greatly reduce the output voltage ripple.

PACKAGE DESCRIPTION

MS Package
10-Lead Plastic MSOP
(Reference LTC DWG # 05-08-1661)

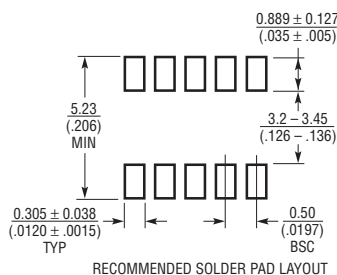

- NOTE:
1. DIMENSIONS IN MILLIMETER/(INCH)
 2. DRAWING NOT TO SCALE
 3. DIMENSION DOES NOT INCLUDE MOLD FLASH, PROTRUSIONS OR GATE BURRS. MOLD FLASH, PROTRUSIONS OR GATE BURRS SHALL NOT EXCEED 0.152mm (.006") PER SIDE
 4. DIMENSION DOES NOT INCLUDE INTERLEAD FLASH OR PROTRUSIONS. INTERLEAD FLASH OR PROTRUSIONS SHALL NOT EXCEED 0.152mm (.006") PER SIDE
 5. LEAD COPLANARITY (BOTTOM OF LEADS AFTER FORMING) SHALL BE 0.102mm (.004") MAX

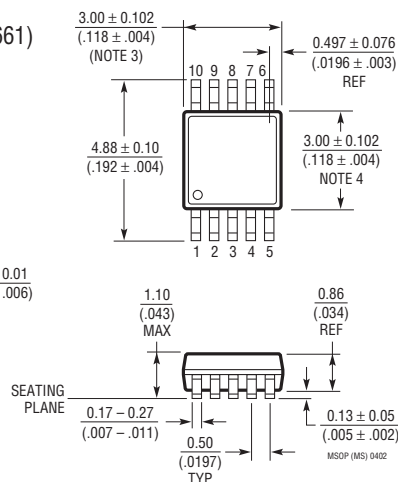
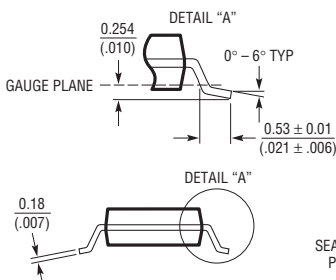

TYPICAL APPLICATIONS

Dual Output ($\pm 32V$) Converter

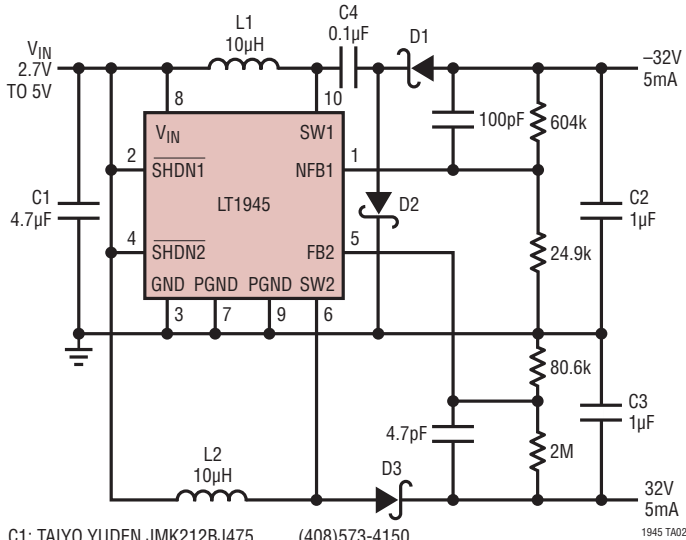

C1: TAIYO YUDEN JMK212BJ475 (408)573-4150
 C2, C3: TAIYO YUDEN GMK316BJ105 (408)573-4150
 C4: TAIYO YUDEN UMK212BJ104 (408)573-4150
 D1, D2, D3: ZETEX ZHCS400 (631)543-7100
 L1, L2: MURATA LQH3C100 (814)237-1431

Efficiency at $V_{IN} = 3.6V$

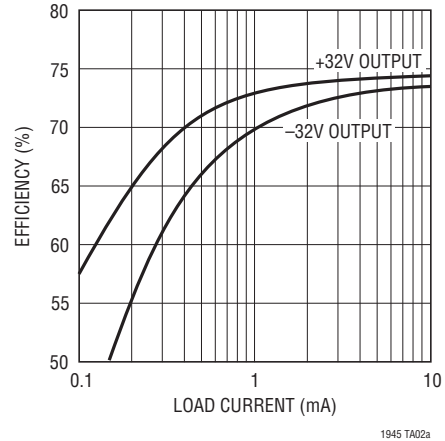

1945 TA02a

RELATED PARTS

PART NUMBER	DESCRIPTION	COMMENTS
LT1613	550mA I_{SW} , 1.4MHz, High Efficiency Step-Up DC/DC Converter	$V_{IN} = 0.9V$ to 10V, $V_{OUT} = 34V$, $I_Q = 3mA$, $I_{SD} < 1\mu A$, ThinSOT Package
LT1615/LT1615-1	300mA I_{SW} , Constant Off-Time, High Efficiency Step-Up DC/DC Converter	$V_{IN} = 1.2V$ to 15V, $V_{OUT} = 34V$, $I_Q = 20\mu A$, $I_{SD} < 1\mu A$, ThinSOT Package
LT1940	Dual Output 1.4A (I_{OUT}), Constant 1.1MHz, High Efficiency Step-Down DC/DC Converter	$V_{IN} = 3V$ to 25V, $V_{OUT} = 1.2V$, $I_Q = 2.5mA$, $I_{SD} < 1\mu A$, TSSOP-16E Package
LT1944	Dual Output 350mA I_{SW} , Constant Off-Time, High Efficiency Step-Up DC/DC Converter	$V_{IN} = 1.2V$ to 15V, $V_{OUT} = 34V$, $I_Q = 20\mu A$, $I_{SD} < 1\mu A$, MS Package
LT1944-1	Dual Output 150mA I_{SW} , Constant Off-Time, High Efficiency Step-Up DC/DC Converter	$V_{IN} = 1.2V$ to 15V, $V_{OUT} = 34V$, $I_Q = 20\mu A$, $I_{SD} < 1\mu A$, MS Package
LT1949/LT1949-1	550mA I_{SW} , 600kHz/1.1MHz, High Efficiency Step-Up DC/DC Converter	$V_{IN} = 1.5V$ to 12V, $V_{OUT} = 28V$, $I_Q = 4.5mA$, $I_{SD} < 25\mu A$, S8, MS8 Packages
LTC3400/LTC3400B	600mA I_{SW} , 1.2MHz, Synchronous Step-Up DC/DC Converter	$V_{IN} = 0.85V$ to 5V, $V_{OUT} = 5V$, $I_Q = 19\mu A/300\mu A$, $I_{SD} < 1\mu A$, ThinSOT Package
LTC3401	1A I_{SW} , 3MHz, Synchronous Step-Up DC/DC Converter	$V_{IN} = 0.5V$ to 5V, $V_{OUT} = 6V$, $I_Q = 38\mu A$, $I_{SD} < 1\mu A$, MS Package
LTC3402	2A I_{SW} , 3MHz, Synchronous Step-Up DC/DC Converter	$V_{IN} = 0.5V$ to 5V, $V_{OUT} = 6V$, $I_Q = 38\mu A$, $I_{SD} < 1\mu A$, MS Package
LTC3423	1A I_{SW} , 3MHz, Low V_{OUT} , Synchronous Step-Up DC/DC Converter	$V_{IN} = 0.5V$ to 5V, $V_{OUT} = 6V$, $I_Q = 38\mu A$, $I_{SD} < 1\mu A$, MS Package
LTC3424	2A I_{SW} , 3MHz, Low V_{OUT} , Synchronous Step-Up DC/DC Converter	$V_{IN} = 0.5V$ to 5V, $V_{OUT} = 6V$, $I_Q = 38\mu A$, $I_{SD} < 1\mu A$, MS Package

X-ON Electronics

Largest Supplier of Electrical and Electronic Components

Click to view similar products for [Switching Voltage Regulators](#) category:

Click to view products by [Linear Technology](#) manufacturer:

Other Similar products are found below :

[TLF30682QVS01XUMA1](#) [TPSM84209RKHR](#) [FAN53526UC106X](#) [FAN53526UC128X](#) [MP1587EN-LF](#) [FAN48610BUC33X](#)
[FAN48617UC50X](#) [FAN53526UC89X](#) [MIC45116-1YMP-T1](#) [NCV891234MW50R2G](#) [EN2342QI](#) [AST1S31PUR](#) [16017](#) [A6986FTR](#)
[NCP81103MNTXG](#) [NCP81203PMNTXG](#) [MAX17242ETPA+](#) [MAX16935RATEB/V+](#) [MP2313GJ-Z](#) [NCP81208MNTXG](#) [MP8759GD-Z](#)
[FAN53526UC100X](#) [FAN53526UC84X](#) [PCA9412AUKZ](#) [MP2314SGJ-Z](#) [AS1340A-BTDM-10](#) [MP3421GG-P](#) [NCP81109GMNTXG](#)
[MP6003DN-LF-Z](#) [MAX16935BAUES/V+](#) [LT8315IFE#PBF](#) [SCY1751FCCT1G](#) [NCP81109JMNTXG](#) [MAX16956AUBA/V+](#)
[AP3409ADNTR-G1](#) [FAN48623UC36FX](#) [MPQ2454GH](#) [MPQ2454GH-AEC1](#) [MP21148GQD-P](#) [AS3701B-BWLM-68](#) [MPQ2143DJ-P](#)
[MP9942AGJ-P](#) [MP8759GD-P](#) [MP5610GQG-P](#) [MP28200GG-P](#) [MP2451DJ-LF-Z](#) [MP2326GD-P](#) [MP2314SGJ-P](#) [MP2158AGQH-P](#)
[MP2148GQD-18-P](#)