



CD40175 (LX) Quad D-type flip-flop

Product Specification

Specification Revision History:

Version	Date	Description
2023-04-A1	2023-04	New
2024-04-A2	2024-04	Modify the content



Contents

1、 General Description.....	3
2、 Block Diagram And Pin Description	4
2.1、 Block Diagram	4
2.2、 Pin Configurations.....	4
2.3、 Pin Description.....	5
2.4、 Function Table.....	5
3、 Electrical Parameter	5
3.1、 Absolute Maximum Ratings.....	5
3.2、 Recommended Operating Conditions.....	6
3.3、 Electrical Characteristics	6
3.3.1、 DC Characteristics 1	6
3.3.2、 DC Characteristics 2.....	7
3.3.3、 AC Characteristics 1	7
3.3.4、 AC Characteristics 2.....	8
4、 Testing Circuit	9
4.1、 AC Testing Circuit	9
4.2、 Test Data	9
4.3、 AC Testing Waveforms.....	9
4.4、 Measurement Points.....	10
5、 Package Information	11
5.1、 DIP16	11
5.2、 SOP16	12
6、 Statements And Notes	13



1、General Description

The CD40175 is a quad edge-triggered D-type flip-flop.

Features:

- Supply voltage range:3V to 15V
- Temperature range:-40°C to +125°C
- Packaging information: DIP16/SOP16

Ordering Information:

Tube packing specifications:

Part number	Packaging form	Marking code	Tube quantity	Boxed tube quantity	Boxed quantity	Notes
CD40175BE(LX)	DIP16	CD40175BE	25 PCS/tube	40 tube/box	1000 PCS/box	Dimensions of plastic enclosure: 19.0mm×6.4mm Pin spacing:2.54mm

Reel packing specifications:

Part number	Packaging form	Marking code	Reel quantity	Boxed reel quantity	Notes
CD40175BM(LX)	SOP16	CD40175BM	4000PCS/reel	8000PCS/box	Dimensions of plastic enclosure: 10.0mm×3.9mm Pin spacing:1.27mm

Note: If the physical information is inconsistent with the ordering information, please refer to the actual product.



2、Block Diagram And Pin Description

2.1、Block Diagram

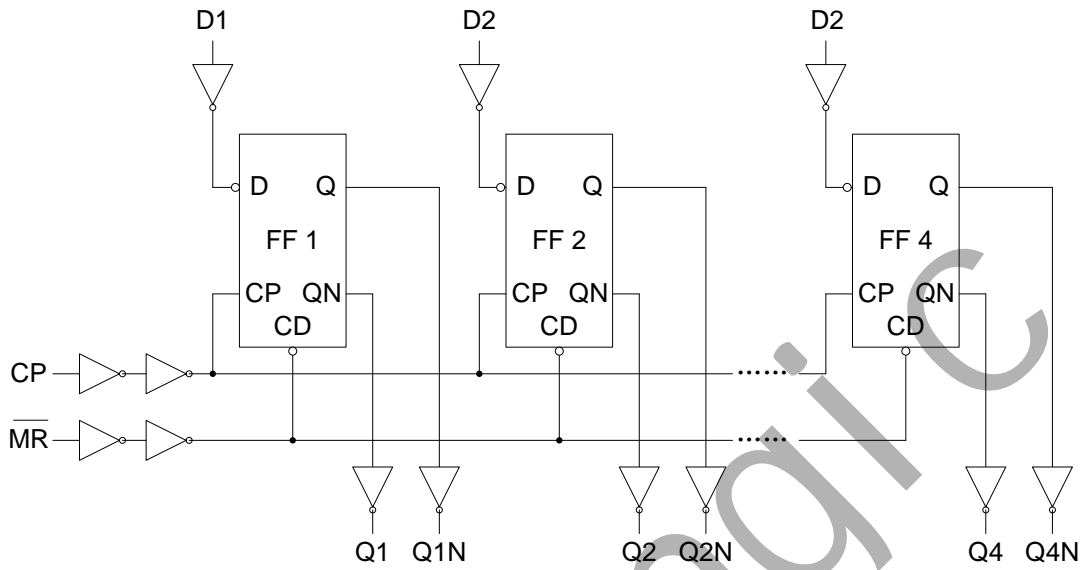
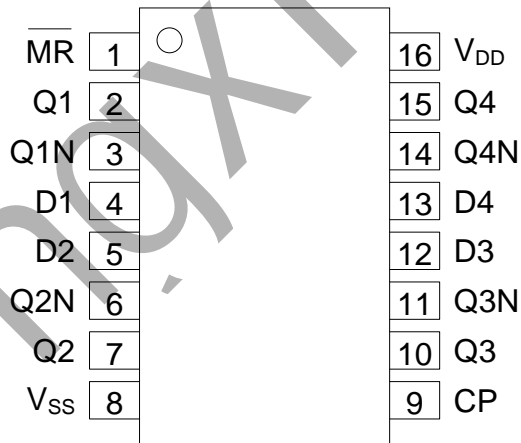

Figure 1. Functional diagram

2.2、Pin Configurations





2.3、Pin Description

Pin No.	Pin Name	Description
1	$\overline{\text{MR}}$	master reset input
2	Q1	buffered output
3	Q1N	complementary buffered output
4	D1	data input
5	D2	data input
6	Q2N	complementary buffered output
7	Q2	buffered output
8	V _{SS}	ground supply voltage
9	CP	clock input
10	Q3	buffered output
11	Q3N	complementary buffered output
12	D3	data input
13	D4	data input
14	Q4N	data input
15	Q4	buffered output
16	V _{DD}	supply voltage

2.4、Function Table

Input			Output
CP	D	$\overline{\text{MR}}$	Qn
↑	H	H	H
↑	L	H	L
↓	X	H	no change
X	X	L	L

Note:

H=HIGH voltage level; L=LOW voltage level. X=don't care;

↑=positive-going transition; ↓= negative-going transition.

3、Electrical Parameter

3.1、Absolute Maximum Ratings

(Voltages are referenced to V_{SS} (ground=0V), unless otherwise specified.)

Parameter	Symbol	Conditions	Min.	Max.	Unit
supply voltage	V _{DD}	-	-0.5	+18	V
input voltage	V _I	all inputs	-0.5	V _{DD} +0.5	V
DC input current	I _{IK}	any one input	-	±10	mA
storage temperature	T _{stg}	-	-65	+150	°C
soldering temperature	T _L	10s	DIP	245	°C
			SOP	260	



3.2、Recommended Operating Conditions

Parameter	Symbol	Conditions	Min.	Typ.	Max.	Unit
supply voltage	V_{DD}	-	3	-	15	V
ambient temperature	T_{amb}	in free air	-40	-	+125	°C

3.3、Electrical Characteristics

3.3.1、DC Characteristics 1

($T_{amb}=-40^{\circ}\text{C}$ to $+85^{\circ}\text{C}$, voltages are referenced to V_{SS} (ground=0V), unless otherwise specified.)

Parameter	Symbol	V_{DD}	Conditions	Min.	Typ.	Max.	Unit
HIGH-level input voltage	V_{IH}	5V	-	3.5	-	-	V
		10V	-	7	-	-	V
		15V	-	11	-	-	V
LOW-level input voltage	V_{IL}	5V	-	-	-	1.5	V
		10V	-	-	-	3	V
		15V	-	-	-	4	V
HIGH-level output voltage	V_{OH}	5V	$ I_O <1\mu\text{A}$	4.95	-	-	V
		10V	$ I_O <1\mu\text{A}$	9.95	-	-	V
		15V	$ I_O <1\mu\text{A}$	14.95	-	-	V
LOW-level output voltage	V_{OL}	5V	$ I_O <1\mu\text{A}$	-	-	0.05	V
		10V	$ I_O <1\mu\text{A}$	-	-	0.05	V
		15V	$ I_O <1\mu\text{A}$	-	-	0.05	V
HIGH-level output current	I_{OH}	5V	$V_O=4.6\text{V}$	-	-	-0.34	mA
		5V	$V_O=2.5\text{V}$	-	-	-1.3	mA
		10V	$V_O=9.5\text{V}$	-	-	-0.55	mA
		15V	$V_O=13.5\text{V}$	-	-	-1.65	mA
LOW-level output current	I_{OL}	5V	$V_O=0.4\text{V}$	0.34	-	-	mA
		10V	$V_O=0.5\text{V}$	0.46	-	-	mA
		15V	$V_O=1.5\text{V}$	1.4	-	-	mA
input leakage current	I_I	15V	$V_I=15\text{V}$ or GND	-	-	± 2	μA
supply current	I_{DD}	5V	$V_I=5\text{V}$ or GND; $I_O=0\text{A}$	-	-	7.5	μA
		10V	$V_I=10\text{V}$ or GND; $I_O=0\text{A}$	-	-	15	μA
		15V	$V_I=15\text{V}$ or GND; $I_O=0\text{A}$	-	-	30	μA



3.3.2、DC Characteristics 2

($T_{amb}=-40^{\circ}\text{C}$ to $+125^{\circ}\text{C}$, voltages are referenced to V_{SS} (ground=0V), unless otherwise specified.)

Parameter	Symbol	V_{DD}	Conditions	Min.	Typ.	Max.	Unit
HIGH-level input voltage	V_{IH}	5V	-	3.5	-	-	V
		10V	-	7	-	-	V
		15V	-	11	-	-	V
LOW-level input voltage	V_{IL}	5V	-	-	-	1.5	V
		10V	-	-	-	3	V
		15V	-	-	-	4	V
HIGH-level output voltage	V_{OH}	5V	$ I_O <1\mu\text{A}$	4.95	-	-	V
		10V	$ I_O <1\mu\text{A}$	9.95	-	-	V
		15V	$ I_O <1\mu\text{A}$	14.95	-	-	V
LOW-level output voltage	V_{OL}	5V	$ I_O <1\mu\text{A}$	-	-	0.05	V
		10V	$ I_O <1\mu\text{A}$	-	-	0.05	V
		15V	$ I_O <1\mu\text{A}$	-	-	0.05	V
HIGH-level output current	I_{OH}	5V	$V_O=4.6\text{V}$	-	-	-0.3	mA
		5V	$V_O=2.5\text{V}$	-	-	-1.15	mA
		10V	$V_O=9.5\text{V}$	-	-	-0.45	mA
		15V	$V_O=13.5\text{V}$	-	-	-1.4	mA
LOW-level output current	I_{OL}	5V	$V_O=0.4\text{V}$	0.29	-	-	mA
		10V	$V_O=0.5\text{V}$	0.38	-	-	mA
		15V	$V_O=1.5\text{V}$	1.2	-	-	mA
input leakage current	I_I	15V	$V_I=15\text{V}$ or GND	-	-	± 4	μA
supply current	I_{DD}	5V	$V_I=5\text{V}$ or GND; $I_O=0\text{A}$	-	-	7.5	μA
		10V	$V_I=10\text{V}$ or GND; $I_O=0\text{A}$	-	-	15	μA
		15V	$V_I=15\text{V}$ or GND; $I_O=0\text{A}$	-	-	30	μA

3.3.3、AC Characteristics 1

($T_{amb}=-40^{\circ}\text{C}$ to $+85^{\circ}\text{C}$, $V_{SS}=0\text{V}$, unless otherwise specified.)

Parameter	Symbol	V_{DD}	Conditions	Min.	Typ.	Max.	Unit
propagation delay time	t_{PHL}, t_{PLH}	5V	CP to Qn See Figure 4	-	70	140	ns
		10V		-	30	65	ns
		15V		-	20	45	ns
$\overline{\text{MR}}$ to Qn HIGH to LOW propagation delay time	t_{PHL}	5V	See Figure 5	-	70	140	ns
		10V		-	30	65	ns
		15V		-	25	50	ns
transition time	t_{THL}, t_{TLH}	5V	See Figure 4	-	60	120	ns
		10V		-	30	60	ns
		15V		-	20	40	ns
set-up time	t_{su}	5V	See Figure 5	60	30	-	ns
		10V		20	10	-	ns
		15V		15	5	-	ns
hold time	t_{hold}	5V		25	-5	-	ns
		10V		10	0	-	ns
		15V		10	0	-	ns



minimum clock pulse width;LOW	t _{WCPL}	5V	90	45	-	ns
		10V	35	15	-	ns
		15V	25	10	-	ns
minimum $\overline{\text{MR}}$ pulse width;LOW	t _{WMRL}	5V	80	40	-	ns
		10V	30	15	-	ns
		15V	20	10	-	ns
recovery time for $\overline{\text{MR}}$	t _{RMRL}	5V	0	-30	-	ns
		10V	0	-20	-	ns
		15V	0	-15	-	ns
maximum clock pulse frequency	f _{max}	5V	5	11	-	MHZ
		10V	15	30	-	MHZ
		15V	20	45	-	MHZ

3.3.4、AC Characteristics 2

(T_{amb}=-40°C to +125°C, V_{SS}=0V, unless otherwise specified.)

Parameter	Symbol	V _{DD}	Conditions	Min.	Typ.	Max.	Unit
propagation delay time	t _{PHL} , t _{PLH}	5V	CP to Qn See Figure 4	-	-	168	ns
		10V		-	-	78	ns
		15V		-	-	54	ns
$\overline{\text{MR}}$ to Qn HIGH to LOW propagation delay time	t _{PHL}	5V	See Figure 5	-	-	168	ns
		10V		-	-	78	ns
		15V		-	-	60	ns
transition time	t _{THL} , t _{TLH}	5V	See Figure 4	-	-	144	ns
		10V		-	-	72	ns
		15V		-	-	48	ns
set-up time	t _{su}	5V	See Figure 5	72	-	-	ns
		10V		24	-	-	ns
		15V		18	-	-	ns
hold time	t _{hold}	5V	See Figure 5	30	-	-	ns
		10V		12	-	-	ns
		15V		12	-	-	ns
minimum clock pulse width; LOW	t _{WCPL}	5V	See Figure 5	108	-	-	ns
		10V		42	-	-	ns
		15V		30	-	-	ns
minimum $\overline{\text{MR}}$ pulse width; LOW	t _{WMRL}	5V	See Figure 5	96	-	-	ns
		10V		36	-	-	ns
		15V		24	-	-	ns
recovery time for $\overline{\text{MR}}$	t _{RMRL}	5V	See Figure 5	0	-	-	ns
		10V		0	-	-	ns
		15V		0	-	-	ns
maximum clock pulse frequency	f _{max}	5V	See Figure 5	4	-	-	MHZ
		10V		12	-	-	MHZ
		15V		16	-	-	MHZ



4、Testing Circuit

4.1、AC Testing Circuit

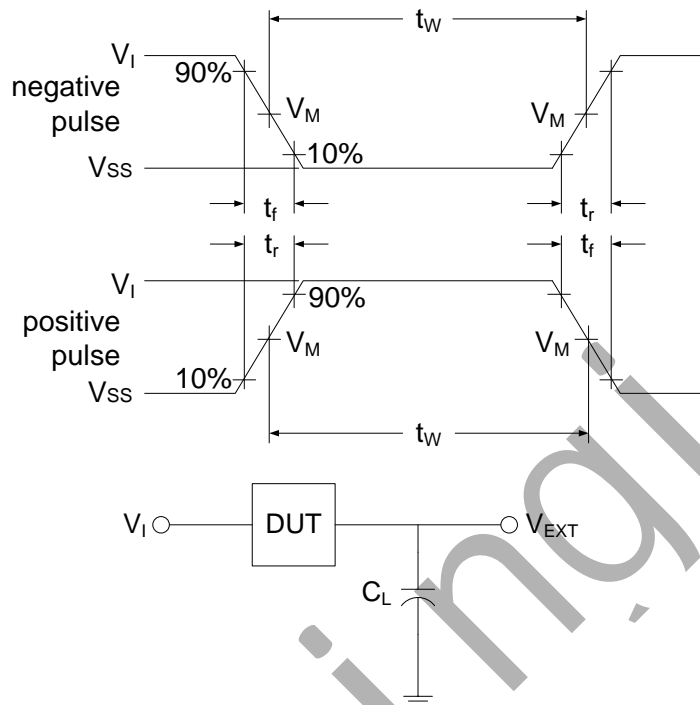

Figure 3. Load circuit

C_L includes probe and jig capacitance.

4.2、Test Data

Supply voltage	Input		Load	V_{EXT}		
V_{DD}	V_I	$t_r = t_f$	C_L	t_{PLH}/t_{PHL}	t_{PLZ}/t_{PZL}	t_{PHZ}/t_{PZH}
5V to 15V	V_{DD}	$\leq 20ns$	50pF	Open	V_{DD}	V_{SS}

4.3、AC Testing Waveforms

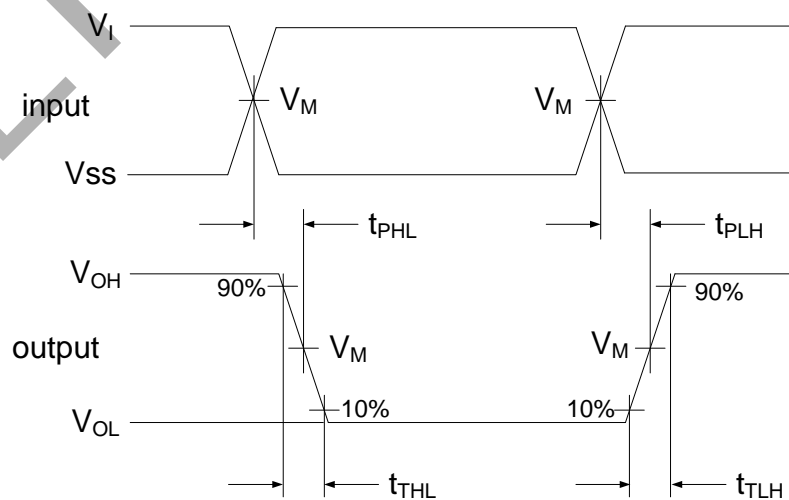

Figure 4. Propagation delay, output transition time

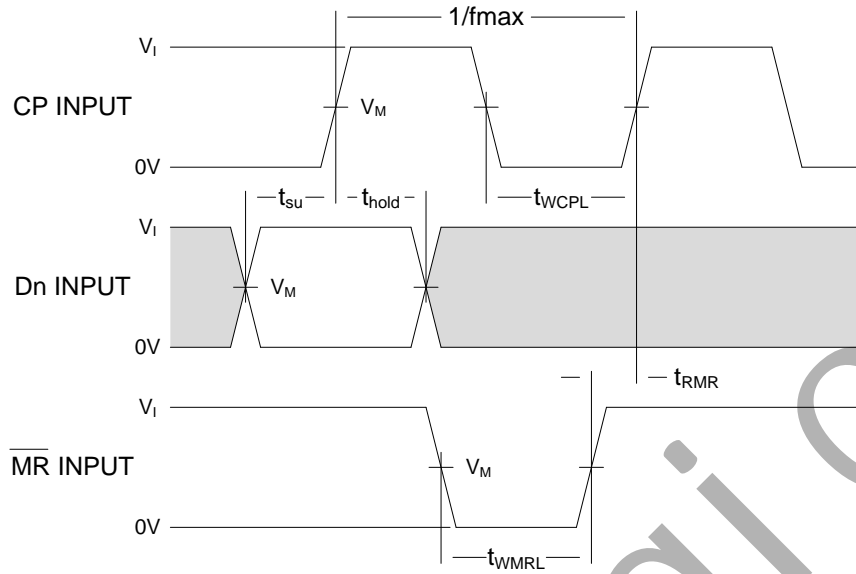

Figure 5. Minimum pulse widths for CP and \overline{MR} , \overline{MR} to CP recovery time, and set-up and hold time for Dn to CP

4.4. Measurement Points

Supply voltage	Input	Output		
V_{DD}	V_M	V_M	V_X	V_Y
5V to 15V	$0.5 \times V_{DD}$	$0.5 \times V_{DD}$	$0.1 \times V_{DD}$	$0.9 \times V_{DD}$



5、Package Information

5.1、DIP16

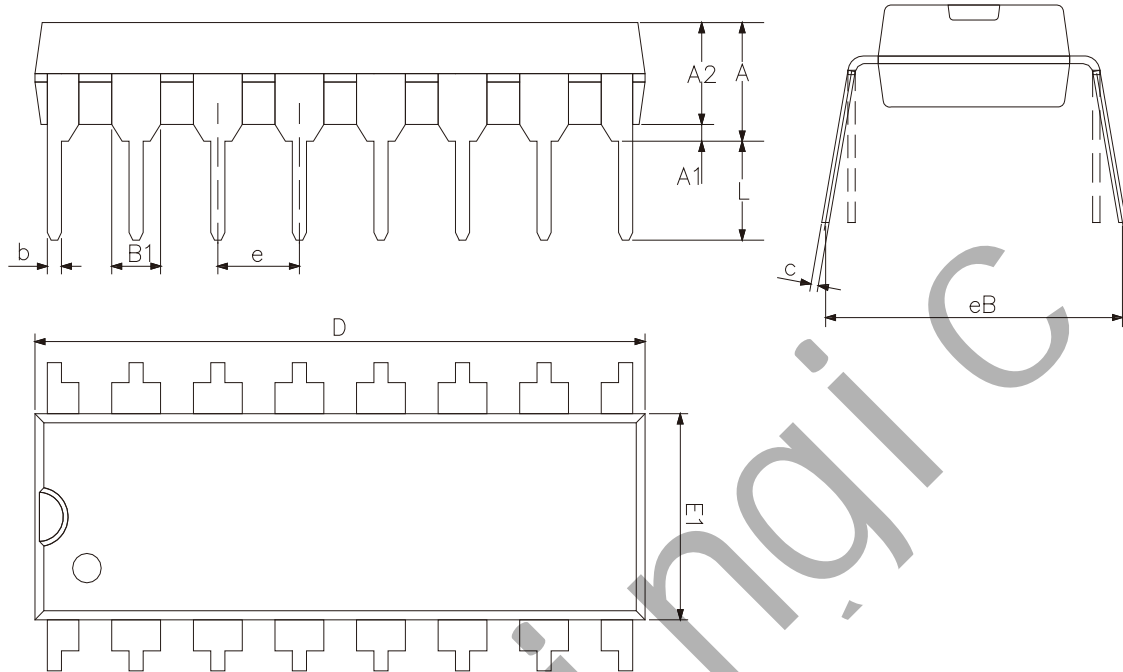

2023/12/A	Dimensions In Millimeters	
Symbol	Min	Max
A2	3.20	3.60
A1	0.51	—
A	3.60	5.33
L	3.00	—
b	0.36	0.56
B1	1.52	
D	18.80	19.94
E1	6.20	6.60
e	2.54	
c	0.20	0.36
eB	7.62	9.30



5.2、SOP16

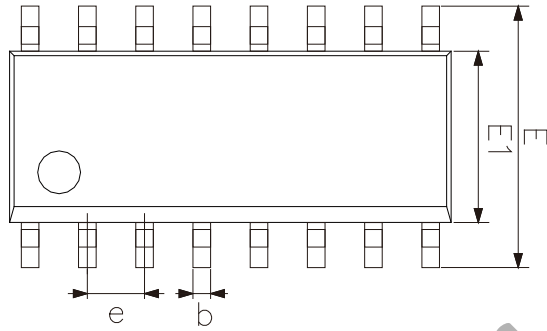
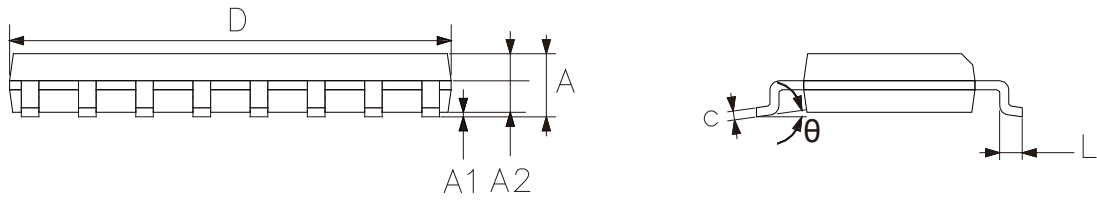

2023/12/A Symbol	Dimensions In Millimeters	
	Min.	Max.
A	1.35	1.80
A1	0.10	0.25
A2	1.25	1.55
b	0.33	0.51
c	0.19	0.25
D	9.50	10.10
E	5.80	6.30
E1	3.70	4.10
e	1.27	
L	0.35	0.89
θ	0°	8°



6、Statements And Notes

Recommended carefully reading this information before the use of this product;

The information in this document are subject to change without notice;

This information is using to the reference only, the company is not responsible for any loss;

The company is not responsible for the any infringement of the third party patents or other rights of the responsibility.

Lingxingic

X-ON Electronics

Largest Supplier of Electrical and Electronic Components

Click to view similar products for [Flip-Flops](#) category:

Click to view products by [lingxingic](#) manufacturer:

Other Similar products are found below :

[NLV74HC74ADTR2G](#) [74F574SC](#) [NLV14013BDR2G](#) [NLV74HC74ADR2G](#) [MC10EP131MNG](#) [MC74AC74DTR2](#) [74VHC574FT\(BJ\)](#)
[HT4093ARZ](#) [SN74HC374ANSR](#) [CD4528BE](#) [CD4027BE](#) [RS74HC74XQ](#) [RS1G79XC5](#) [CD40106BM-JSM](#) [74HCT273PW-Q100J](#)
[CLVC2G74QDCURG4Q1](#) [CD4067TA24.TB](#) [CD4013SA.TR](#) [AIP74HCT14TA14.TB](#) [CD4013BPWRG](#) [AiP74LVC74TA14.TB](#)
[CD4013BDRG](#) [CD4528SA16.TR](#) [AIP74HC273SA.TB](#) [SN74HCS74QDYRQ1](#) [CD4013TA14.TB](#) [SN74LS107N](#) [SN74LS374DWR](#)
[SN74LVC2G14DC\(LX\)](#) [74VHCT574AFT](#) [TC4013BF\(EL,N,F\)](#) [74VHCT9541AFT](#) [74LCX374FT\(AJ\)](#) [TC7WZ74FK,LXGJ\(CT](#)
[74LCX374FT](#) [74VHC174FT\(TB,BJ\)](#) [TC7WH74FK,LJ](#) [SN74HC374PW\(LX\)](#) [SN74LVC1G17DC\(LX\)](#) [SN74HC174DR\(LX\)](#)
[SN74HC112N\(LX\)](#) [SN74HC74DR\(LX\)](#) [CD40174BE\(LX\)](#) [CD40175BE\(LX\)](#) [SN74LS374N](#) [SN74HC173N](#) [SN74HC107DR\(LX\)](#)
[SN74HC107N\(LX\)](#) [SN74LS174DR\(LX\)](#) [SN74LS273N\(LX\)](#)