



# CD4017 (LX)

## 5-stage Johnson Decade Counter

### Product Specification

#### Specification Revision History:

Version	Date	Description
2021-12-A1	2021-12	New



## 1、General Description

The CD4017 is a 5-stage Johnson decade counter with ten spike-free decoded active HIGH outputs (Q0 to Q9), an active LOW carry output from the most significant flip-flop ( $\overline{Q5-9}$ ), active HIGH and active LOW clock inputs (CP0,  $\overline{CP1}$ ) and an overriding asynchronous master reset input (MR).

The counter is advanced by either a LOW-to-HIGH transition at CP0 while  $\overline{CP1}$  is LOW or a HIGH-to-LOW transition at  $\overline{CP1}$  while CP0 is HIGH.

When cascading counters, the  $\overline{Q5-9}$  output, which is LOW while the counter is in states 5, 6, 7, 8, and 9, can be used to drive the CP0 input of the next counter. A HIGH on MR resets the counter to zero (Q0= $\overline{Q5-9}$ =HIGH; Q1 to Q9=LOW) independent of the clock inputs (CP0,  $\overline{CP1}$ ).

Automatic counter code correction is provided by an internal circuit: following any illegal code the counter returns to a proper counting mode within 11 clock pulses.

It operates over a recommended  $V_{DD}$  power supply range of 3V to 15V referenced to  $V_{SS}$  (usually ground). Unused inputs must be connected to  $V_{DD}$ ,  $V_{SS}$ , or another input.

### Features:

- Wide supply voltage range from 3V to 15V
- Automatic counter correction
- Tolerant of slow clock rise and fall times
- 5V, 10V, and 15V parametric ratings
- Standardized symmetrical output characteristics
- Specified from  $-40^{\circ}\text{C}$  to  $+125^{\circ}\text{C}$
- Packaging information: DIP16/SOP16/TSSOP16

**Ordering Information:****Tube packing specifications:**

Type number	Packaging form	Marking code	Tube quantity	Boxed tube quantity	Boxed quantity	Packing box number	Packing quantity	Notes
CD4017BE(LX)	DIP16	CD4017BE	25 PCS/tube	40 tube/box	1000 PCS/box	10 box/pack	10000 PCS/pack	Dimensions of plastic enclosure: 19.0mm×6.4mm Pin spacing: 2.54mm

**Reel packing specifications:**

Type number	Packaging form	Marking code	Reel quantity	Boxed reel quantity	Packing quantity	Notes
CD4017BM(LX)	SOP16	CD4017BM	4000 PCS/reel	8000 PCS/box	64000 PCS/pack	Dimensions of plastic enclosure: 10.0mm×3.9mm Pin spacing:1.27mm
CD4017BPW(LX)	TSSOP16	CD4017	5000 PCS/reel	10000 PCS/box	80000 PCS/pack	Dimensions of plastic enclosure: 5.0mm×4.4mm Pin spacing:0.65mm

Note: If the physical information is inconsistent with the ordering information, please refer to the actual product.



## 2、Block Diagram And Pin Description

### 2.1、Block Diagram

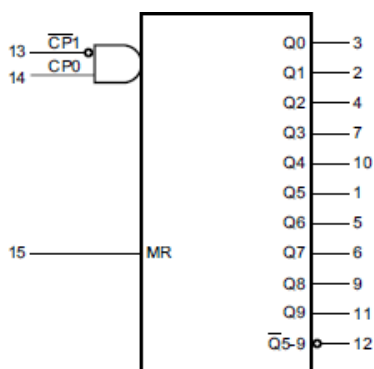

Figure 1. Logic symbol

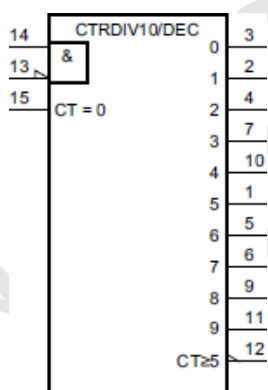

Figure 2. IEE logic symbol

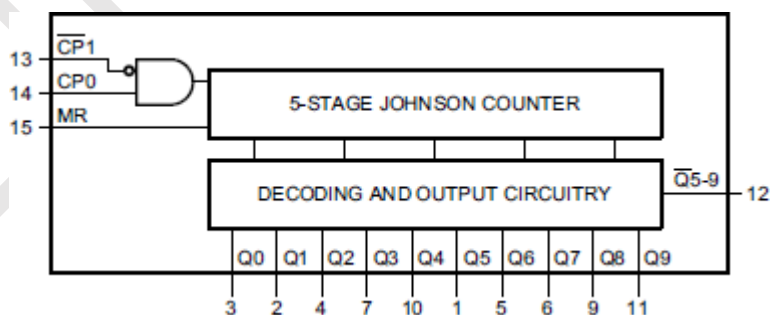

Figure 3. Functional diagram

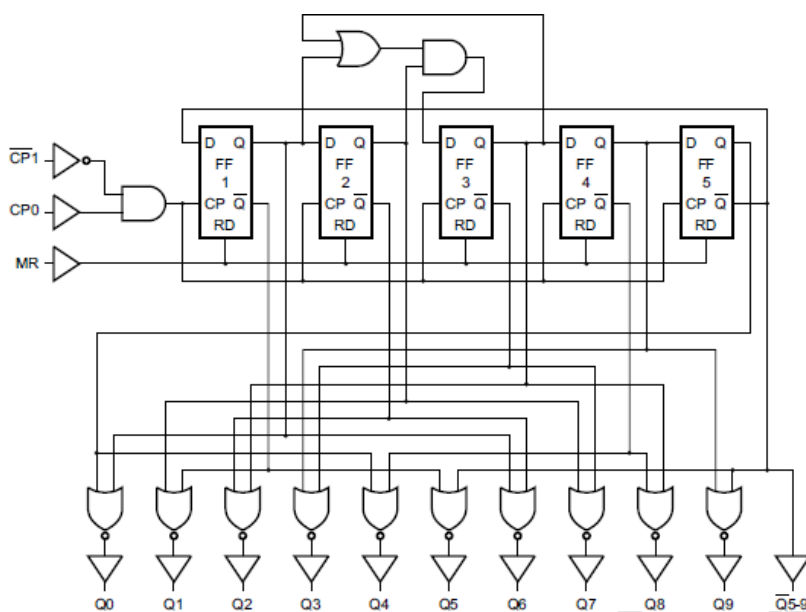

Figure 4. Logic diagram

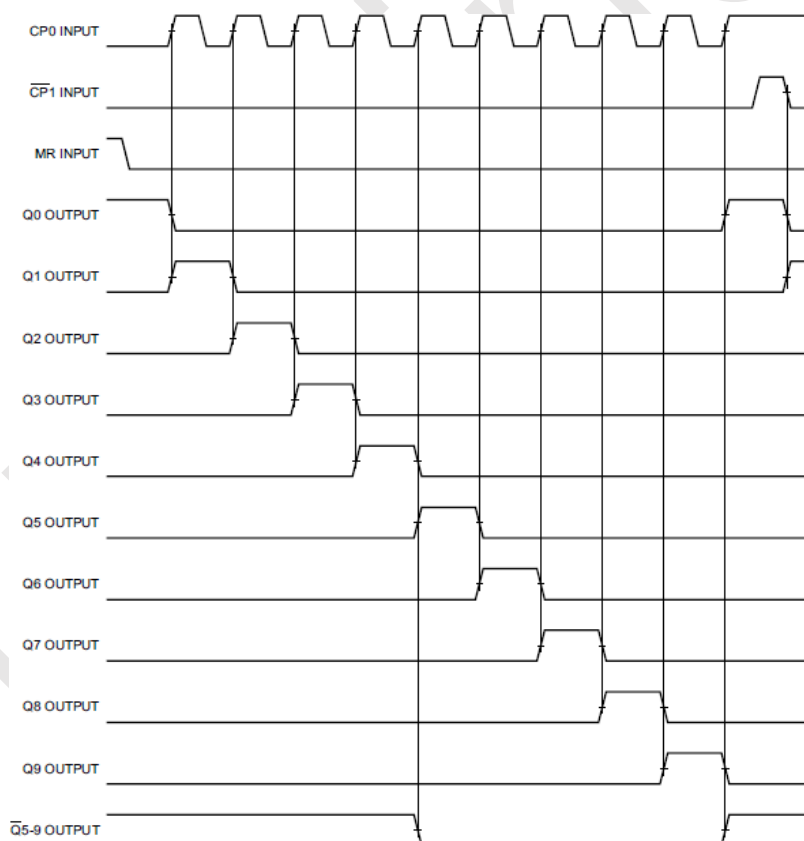
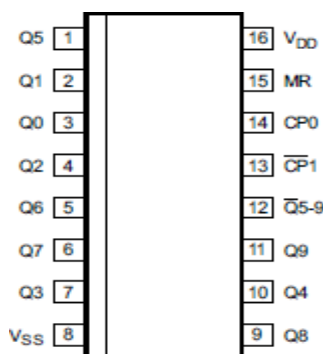

Figure 5. Timing diagram



## 2.2、Pin Configurations



## 2.3、Pin Description

Pin No.	Pin Name	Description
1	Q5	decoded output
2	Q1	decoded output
3	Q0	decoded output
4	Q2	decoded output
5	Q6	decoded output
6	Q7	decoded output
7	Q3	decoded output
8	V <sub>SS</sub>	ground (0V)
9	Q8	decoded output
10	Q4	decoded output
11	Q9	decoded output
12	Q5-9	carry output (active LOW)
13	CP1	clock input (HIGH-to-LOW edge-triggered)
14	CP0	clock input (LOW-to-HIGH edge-triggered)
15	MR	master reset input
16	V <sub>DD</sub>	supply voltage

## 2.4、Function Table

Input			Operation
MR	CP0	CP1	
H	X	X	Q0=Q5-9=H; Q1 to Q9=L
L	H	↓	counter advances
L	↑	L	counter advances
L	L	X	no change
L	X	H	no change
L	H	↑	no change
L	↓	L	no change

Note: H=HIGH voltage level; L=LOW voltage level; X=don't care;

↑=positive-going transition; ↓=negative-going transition.



### 3、Electrical Parameter

#### 3.1、Absolute Maximum Ratings

(Voltages are referenced to  $V_{SS}$  (ground=0V), unless otherwise specified.)

Parameter	Symbol	Conditions	Min.	Max.	Unit	
supply voltage	$V_{DD}$	-	-0.5	+18	V	
DC input current	$I_{IK}$	any one input	-	$\pm 10$	mA	
input voltage	$V_I$	all inputs	-0.5	$V_{DD}+0.5$	V	
storage temperature	$T_{stg}$	-	-65	+150	$^{\circ}C$	
total power dissipation	$P_{tot}$	-	-	500	mW	
device dissipation	P	per output transistor	-	100	mW	
Soldering temperature	$T_L$	10s	DIP	245		$^{\circ}C$
			SOP	250		

Note:

[1] For DIP16 packages: above  $70^{\circ}C$  the value of  $P_{tot}$  derates linearly with 12mW/K.

[2] For SOP16 packages: above  $70^{\circ}C$  the value of  $P_{tot}$  derates linearly with 8mW/K.

[3] For (T)SSOP16 packages: above  $60^{\circ}C$  the value of  $P_{tot}$  derates linearly with 5.5mW/K.

#### 3.2、Recommended Operating Conditions

Parameter	Symbol	Conditions	Min.	Typ.	Max.	Unit
supply voltage	$V_{DD}$	-	3	-	15	V
ambient temperature	$T_{amb}$	in free air	-40	-	+85	$^{\circ}C$
clock input frequency	$f_{CL}$	$V_{DD}=5V$	-	-	2.5	MHz
		$V_{DD}=10V$	-	-	5	MHz
		$V_{DD}=15V$	-	-	5.5	MHz
clock pulse width	$t_w$	$V_{DD}=5V$	200	-	-	ns
		$V_{DD}=10V$	90	-	-	ns
		$V_{DD}=15V$	60	-	-	ns
clock rise and fall time	$t_{rCL}, t_{fCL}$	$V_{DD}=5V$	unlimited			-
		$V_{DD}=10V$	unlimited			-
		$V_{DD}=15V$	unlimited			-
clock inhibit setup time	$t_s$	$V_{DD}=5V$	230	-	-	ns
		$V_{DD}=10V$	100	-	-	ns
		$V_{DD}=15V$	70	-	-	ns
reset pulse width	$t_{RW}$	$V_{DD}=5V$	260	-	-	ns
		$V_{DD}=10V$	110	-	-	ns
		$V_{DD}=15V$	60	-	-	ns
reset removal time	$t_{rec}$	$V_{DD}=5V$	400	-	-	ns
		$V_{DD}=10V$	280	-	-	ns
		$V_{DD}=15V$	150	-	-	ns



### 3.3、Electrical Characteristics

#### 3.3.1、DC Characteristics 1

( $T_{amb}=25^{\circ}\text{C}$ , voltages are referenced to  $V_{SS}$  (ground=0V), unless otherwise specified.)

Parameter	Symbol	Conditions (V)			$T_{amb}=25^{\circ}\text{C}$			Unit
		$V_O$	$V_{IN}$	$V_{DD}$	Min.	Typ.	Max.	
supply current	$I_{DD}$	-	0, 5	5	-	0.04	5	uA
		-	0, 10	10	-	0.04	10	uA
		-	0, 15	15	-	0.04	20	uA
LOW-level output current	$I_{OL}$	0.4	0, 5	5	0.51	1	-	mA
		0.5	0, 10	10	1.3	2.6	-	mA
		1.5	0, 15	15	3.4	6.8	-	mA
HIGH-level output current	$I_{OH}$	4.6	0, 5	5	-0.51	-1	-	mA
		2.5	0, 5	5	-1.6	-3.2	-	mA
		9.5	0, 10	10	-1.3	-2.6	-	mA
		13.5	0, 15	15	-3.4	-6.8	-	mA
LOW-level output voltage	$V_{OL}$	-	0, 5	5	-	0	0.05	V
		-	0, 10	10	-	0	0.05	V
		-	0, 15	15	-	0	0.05	V
HIGH-level output voltage	$V_{OH}$	-	0, 5	5	4.95	5	-	V
		-	0, 10	10	9.95	10	-	V
		-	0, 15	15	14.95	15	-	V
LOW-level input voltage	$V_{IL}$	0.5, 4.5	-	5	-	-	1.5	V
		1, 9	-	10	-	-	3	V
		1.5, 13.5	-	15	-	-	4	V
HIGH-level input voltage	$V_{IH}$	0.5, 4.5	-	5	3.5	-	-	V
		1, 9	-	10	7	-	-	V
		1.5, 13.5	-	15	11	-	-	V
input leakage current	$I_I$	-	0, 15	15	-	$\pm 10^{-5}$	$\pm 0.1$	uA

#### 3.3.2、DC Characteristics 2

( $T_{amb}=-40^{\circ}\text{C}$  to  $+85^{\circ}\text{C}$ , voltages are referenced to  $V_{SS}$  (ground=0V), unless otherwise specified.)

Parameter	Symbol	Conditions (V)			$T_{amb}=-40^{\circ}\text{C}$		$T_{amb}=+85^{\circ}\text{C}$		Unit
		$V_O$	$V_{IN}$	$V_{DD}$	Min.	Max.	Min.	Max.	
supply current	$I_{DD}$	-	0, 5	5	-	5	-	150	uA
		-	0, 10	10	-	10	-	300	uA
		-	0, 15	15	-	20	-	600	uA
LOW-level output current	$I_{OL}$	0.4	0, 5	5	0.61	-	0.42	-	mA
		0.5	0, 10	10	1.5	-	1.1	-	mA
		1.5	0, 15	15	4	-	2.8	-	mA
HIGH-level output current	$I_{OH}$	4.6	0, 5	5	-0.61	-	-0.42	-	mA
		2.5	0, 5	5	-1.8	-	-1.3	-	mA
		9.5	0, 10	10	-1.5	-	-1.1	-	mA
		13.5	0, 15	15	-4	-	-2.8	-	mA
LOW-level output voltage	$V_{OL}$	-	0, 5	5	-	0.05	-	0.05	V
		-	0, 10	10	-	0.05	-	0.05	V





		-	0, 15	15	-	0.05	-	0.05	V
HIGH-level output voltage	V <sub>OH</sub>	-	0, 5	5	4.95	-	4.95	-	V
		-	0, 10	10	9.95	-	9.95	-	V
		-	0, 15	15	14.95	-	14.95	-	V
LOW-level input voltage	V <sub>IL</sub>	0.5, 4.5	-	5	-	1.5	-	1.5	V
		1, 9	-	10	-	3	-	3	V
		1.5, 13.5	-	15	-	4	-	4	V
HIGH-level input voltage	V <sub>IH</sub>	0.5, 4.5	-	5	3.5	-	3.5	-	V
		1, 9	-	10	7	-	7	-	V
		1.5, 13.5	-	15	11	-	11	-	V
input leakage current	I <sub>I</sub>	-	0, 15	15	-	±0.1	-	±1	uA

### 3.3.3、AC Characteristics

(T<sub>amb</sub>=25°C, V<sub>SS</sub>=0V, t<sub>r</sub>, t<sub>f</sub>=20ns, C<sub>L</sub>=50pF, R<sub>L</sub>=200kΩ, unless otherwise specified.)

Parameter	Symbol	Conditions	Min.	Typ.	Max.	Unit	
propagation delay time	t <sub>PHL</sub> , t <sub>PLH</sub>	CP0, CP1 to Q0 to Q9; see Figure 7	V <sub>DD</sub> =5V	-	325	650	ns
			V <sub>DD</sub> =10V	-	135	270	ns
			V <sub>DD</sub> =15V	-	85	170	ns
		CP0, CP1 to Q5-9; see Figure 7	V <sub>DD</sub> =5V	-	300	600	ns
			V <sub>DD</sub> =10V	-	125	250	ns
			V <sub>DD</sub> =15V	-	80	160	ns
		MR to Q0 to Q9; see Figure 7	V <sub>DD</sub> =5V	-	265	530	ns
			V <sub>DD</sub> =10V	-	115	230	ns
			V <sub>DD</sub> =15V	-	85	170	ns
transition time	t <sub>t</sub>	see Figure 7	V <sub>DD</sub> =5V	-	100	200	ns
			V <sub>DD</sub> =10V	-	50	100	ns
			V <sub>DD</sub> =15V	-	40	80	ns
pulse width	t <sub>w</sub>	see Figure 8	V <sub>DD</sub> =5V	-	100	200	ns
			V <sub>DD</sub> =10V	-	45	90	ns
			V <sub>DD</sub> =15V	-	30	60	ns
clock rise and fall time	t <sub>rCL</sub> , t <sub>fCL</sub>	-	V <sub>DD</sub> =5V	unlimited			-
			V <sub>DD</sub> =10V	unlimited			-
			V <sub>DD</sub> =15V	unlimited			-
maximum clock frequency	f <sub>CL</sub>	see Figure 8	V <sub>DD</sub> =5V	2.5	5	-	MHz
			V <sub>DD</sub> =10V	5	10	-	MHz
			V <sub>DD</sub> =15V	5.5	11	-	MHz
setup time	t <sub>s</sub>	CP0 to CP1; see Figure 9	V <sub>DD</sub> =5V	-	115	230	ns
			V <sub>DD</sub> =10V	-	50	100	ns
			V <sub>DD</sub> =15V	-	35	70	ns
reset removal time	t <sub>rec</sub>	MR input; see Figure 8	V <sub>DD</sub> =5V	-	200	400	ns
			V <sub>DD</sub> =10V	-	140	280	ns
			V <sub>DD</sub> =15V	-	75	150	ns
input capacitance	C <sub>I</sub>	any input	-	5	-	pF	

Note: t<sub>t</sub> is the same as t<sub>TLH</sub> and t<sub>THL</sub>.

## 4、Testing Circuit

### 4.1、AC Testing Circuit

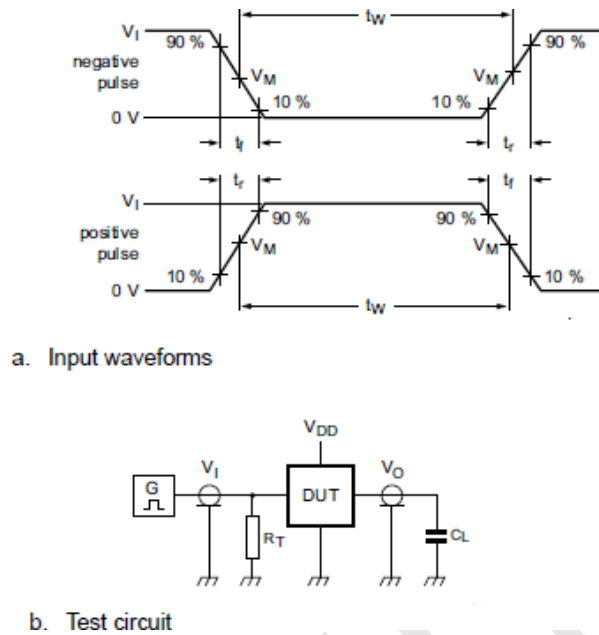

Figure 6. Test circuit for switching times

Definitions for test circuit:

DUT=Device Under Test.

$C_L$ =Load capacitance including jig and probe capacitance.

$R_T$ =Termination resistance should be equal to the output impedance  $Z_o$  of the pulse generator.

### 4.2、AC Testing Waveforms

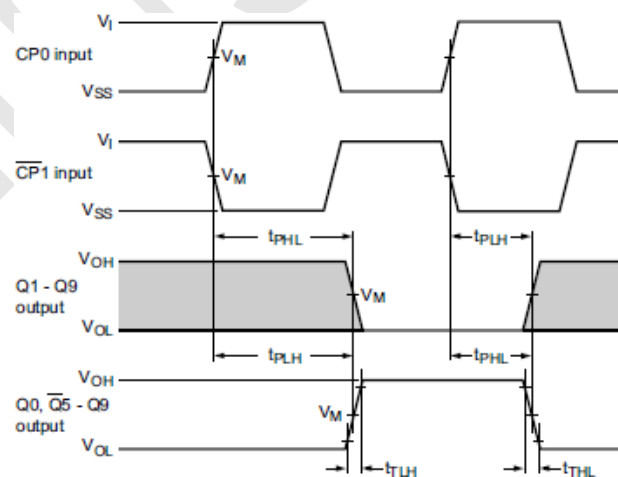

Figure 7. Waveforms showing the propagation delays for CP0, CP1 to Qn, Q5-9 outputs and the output transition times

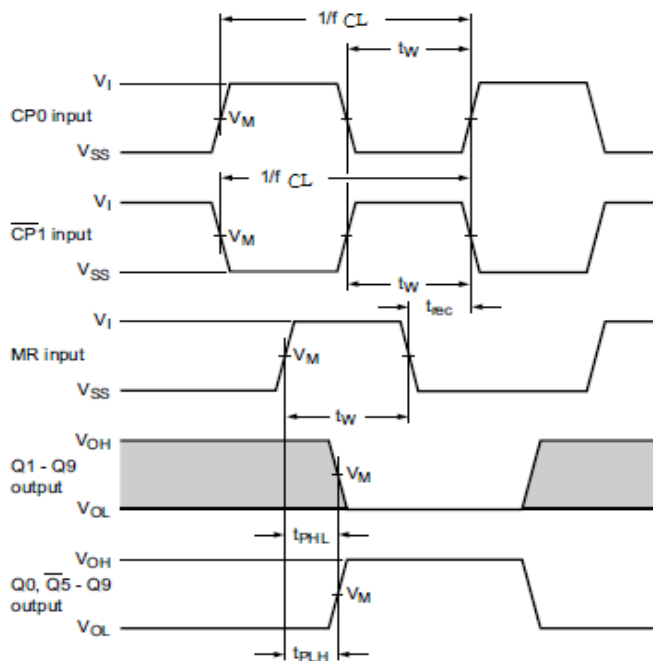

Figure 8. Waveforms showing the minimum pulse width for CP0, CP1 and MR input; the maximum frequency for CP0 and CP1 input; the recovery time for MR and the MR input to Qn and Q5-9 output propagation delay

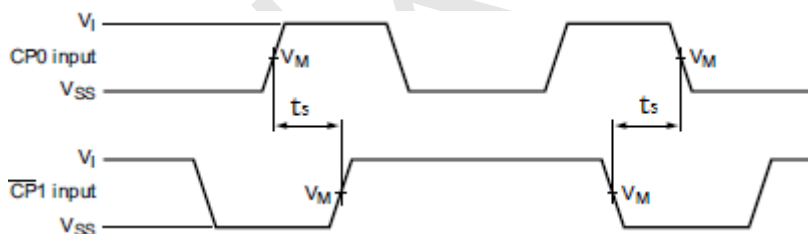

Figure 9. Waveforms showing hold times for CP0 to CP1 and CP1 to CP0

#### 4.3 Measurement Points

Supply voltage	Input	Output
$V_{DD}$	$V_M$	$V_M$
5V to 15V	$0.5 \times V_{DD}$	$0.5 \times V_{DD}$

#### 4.4 Test Data

Supply voltage	Input		Load
$V_{DD}$	$V_I$	$t_r, t_f$	$C_L$
5V to 15V	$V_{SS}$ or $V_{DD}$	$\leq 20ns$	50pF



## 5、Package Information

### 5.1、DIP16

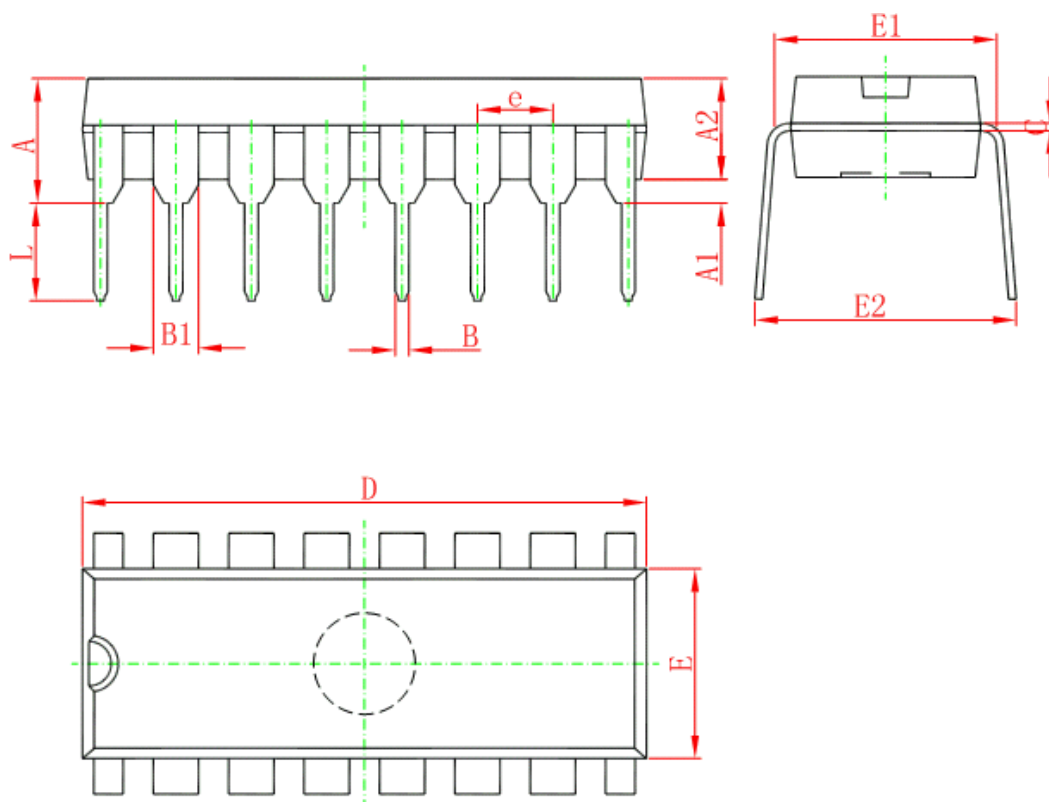

Symbol	Dimensions In Millimeters		Dimensions In Inches	
	Min	Max	Min	Max
A	3.710	4.310	0.146	0.170
A1	0.510		0.020	
A2	3.200	3.600	0.126	0.142
B	0.380	0.570	0.015	0.022
B1	1.524 (BSC)		0.060 (BSC)	
C	0.204	0.360	0.008	0.014
D	18.800	19.200	0.740	0.756
E	6.200	6.600	0.244	0.260
E1	7.320	7.920	0.288	0.312
e	2.540 (BSC)		0.100 (BSC)	
L	3.000	3.600	0.118	0.142
E2	8.400	9.000	0.331	0.354



5.2、SOP16

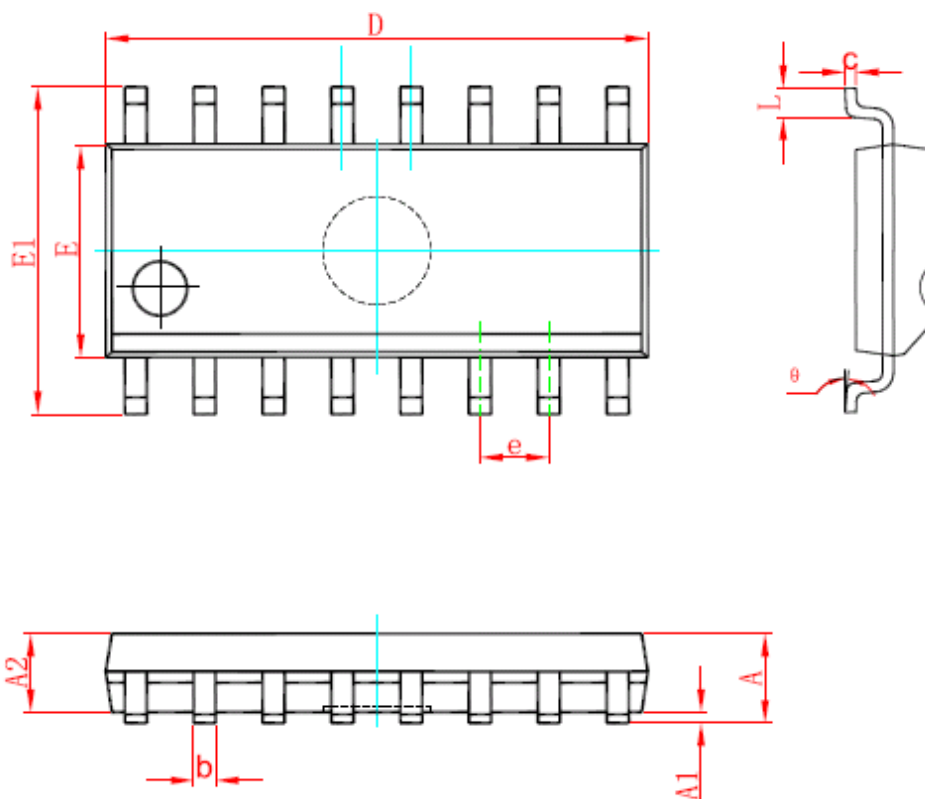

Symbol	Dimensions In Millimeters		Dimensions In Inches	
	Min	Max	Min	Max
A	1.350	1.750	0.053	0.069
A1	0.100	0.250	0.004	0.010
A2	1.350	1.550	0.053	0.061
b	0.330	0.510	0.013	0.020
c	0.170	0.250	0.007	0.010
D	9.800	10.200	0.386	0.402
E	3.800	4.000	0.150	0.157
E1	5.800	6.200	0.228	0.244
e	1.270 (BSC)		0.050 (BSC)	
L	0.400	1.270	0.016	0.050
θ	0°	8°	0°	8°



5.3、TSSOP16

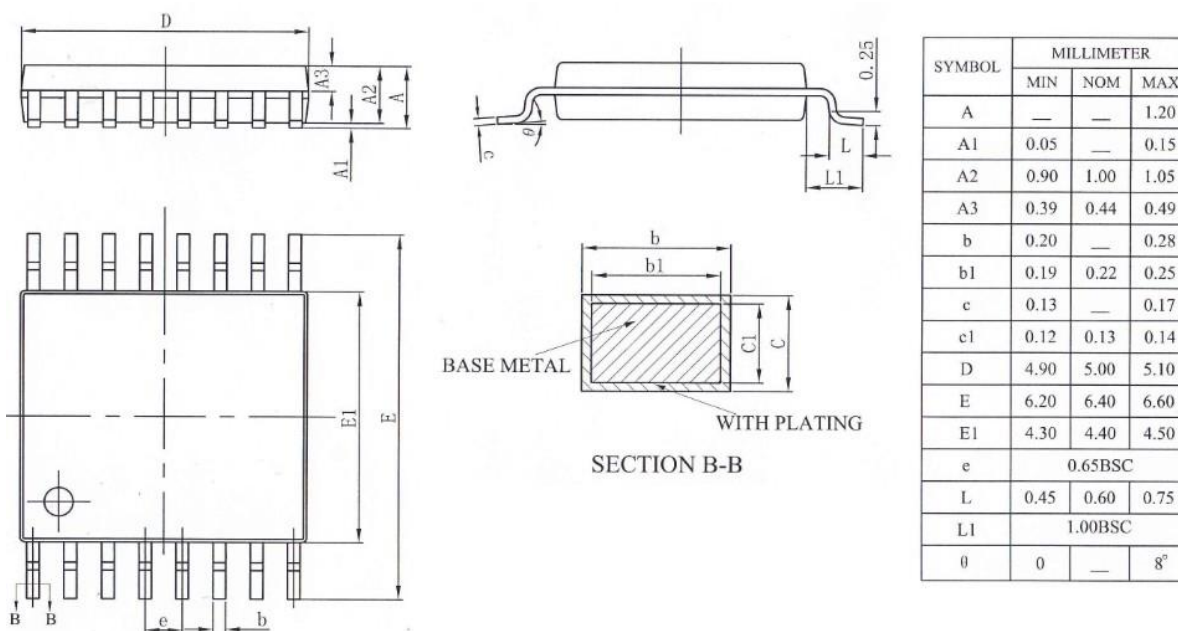

6、Statements And Notes

6.1、The name and content of Hazardous substances or Elements in the product

Part name	Hazardous substances or Elements									
	Lead and lead compounds	Mercury and mercury compounds	Cadmium and cadmium compounds	Hexavalent chromium compounds	Polybrominated biphenyls	Polybrominated biphenyl ethers	Dibutyl phthalate	Butylbenzyl phthalate	Di-2-ethylhexyl phthalate	Diisobutyl phthalate
Lead frame	○	○	○	○	○	○	○	○	○	○
Plastic resin	○	○	○	○	○	○	○	○	○	○
Chip	○	○	○	○	○	○	○	○	○	○
The lead	○	○	○	○	○	○	○	○	○	○
Plastic sheet installed	○	○	○	○	○	○	○	○	○	○
explanation	○: Indicates that the content of hazardous substances or elements in the detection limit of the following the SJ/T11363-2006 standard. ×: Indicates that the content of hazardous substances or elements exceeding the SJ/T11363-2006 Standard limit requirements.									

6.2、Notion

Recommended carefully reading this information before the use of this product;

The information in this document are subject to change without notice;

This information is using to the reference only, the company is not responsible for any loss;

The company is not responsible for the any infringement of the third party patents or other rights of the responsibility.

## X-ON Electronics

Largest Supplier of Electrical and Electronic Components

*Click to view similar products for [Counter ICs](#) category:*

*Click to view products by [lingxingic](#) manufacturer:*

Other Similar products are found below :

[CD4018BE](#) [CD4033BE](#) [CD4060BE](#) [CD4040BE](#) [NLV14040BDR2G](#) [RFDIP1607ALM9T21](#) [RFDIP1606L708D1T](#) [RFTIP2510T12A8Q1C](#)  
[74HC161DT](#) [CD4028BM/TR](#) [CD4060DM/TR](#) [CD4022BE](#) [CD4060DMT/TR](#) [CD4060BMT/TR](#) [74HC192M/TR](#) [CD4020BMT/TR](#)  
[74HC193M/TR](#) [CD4518BM/TR](#) [CD4060TA16.TB](#) [CD4060DE](#) [CD4017CN](#) [CD4017SA.TB](#) [CD4022BM/TR](#) [CD4022BMT/TR](#)  
[CD4028BDRG](#) [CD4060BDRG](#) [CD4017DA.TB](#) [CD4520BDRG](#) [CD4520BM\(LX\)](#) [CD4518BM\(LX\)](#) [SN74HC393DR\(LX\)](#) [CD4060BM\(LX\)](#)  
[CD4060BE\(LX\)](#) [SN74HC192N\(XBLW\)](#) [CD4040BM\(LX\)](#) [CD4026BM\(LX\)](#) [CD40103BDR\(LX\)](#) [SN74LS192DR\(LX\)](#) [SN74HC161DR \(LX\)](#)  
[CD40193BE\(LX\)](#) [CD4060BDTR\(XBLW\)](#) [SN74LS393DR](#) [SN74LS193N\(LX\)](#) [SN74LS193DR\(LX\)](#) [CD4017BM\(LX\)](#) [CD40193BM\(LX\)](#)  
[SN74LS192N\(LX\)](#) [SN74LS160N\(LX\)](#) [SN74LS161N\(LX\)](#) [CD4024BM\(LX\)](#)