



CD40192 (LX)

4-bit up/down BCD counter

Product Specification

Specification Revision History:

Version	Date	Description
2023-04-A1	2023-04	New
2024-04-A2	2024-04	Modify the content



Contents

1、 General Description.....	3
2、 Block Diagram And Pin Description	4
2.1、 Block Diagram	4
2.2、 Pin Configurations.....	4
2.3、 Pin Description.....	5
2.4、 Function Table.....	5
3、 Electrical Parameter	5
3.1、 Absolute Maximum Ratings.....	5
3.2、 Recommended Operating Conditions.....	6
3.3、 Electrical Characteristics	6
3.3.1、 DC Characteristics 1	6
3.3.2、 DC Characteristics 2.....	7
3.3.3、 AC Characteristics 1	7
3.3.4、 AC Characteristics 2.....	9
4、 Testing Circuit	11
4.1、 AC Testing Circuit	11
4.2、 Test Data	11
4.3、 AC Testing Waveforms.....	11
4.4、 Measurement Points	12
5、 Package Information	13
5.1、 DIP16	13
5.2、 SOP16	14
6、 Statements And Notes	15



1、General Description

The CD40192 is a 4-bit synchronous up/down BCD counter.

Features:

- Supply voltage range:3V to 15V
- Temperature range:-40°C to +125°C
- Packaging information: DIP16/SOP16

Ordering Information:

Tube packing specifications:

Part number	Packaging form	Marking code	Tube quantity	Boxed tube quantity	Boxed quantity	Notes
CD40192BE(LX)	DIP16	CD40192BE	25 PCS/tube	40 tube/box	1000 PCS/box	Dimensions of plastic enclosure: 19.0mm×6.4mm Pin spacing:2.54mm

Reel packing specifications:

Part number	Packaging form	Marking code	Reel quantity	Boxed reel quantity	Notes
CD40192BM(LX)	SOP16	CD40192BM	4000PCS/reel	8000PCS/box	Dimensions of plastic enclosure: 10.0mm×3.9mm Pin spacing:1.27mm

Note: If the physical information is inconsistent with the ordering information, please refer to the actual product.



2、Block Diagram And Pin Description

2.1、Block Diagram

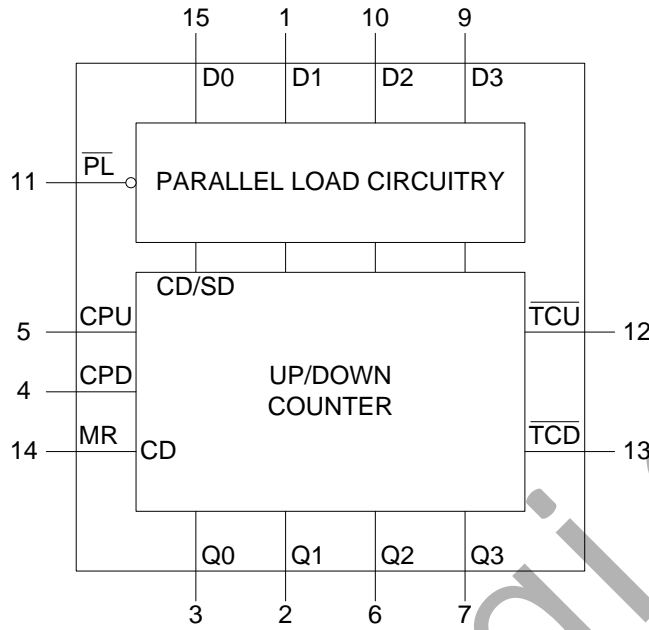
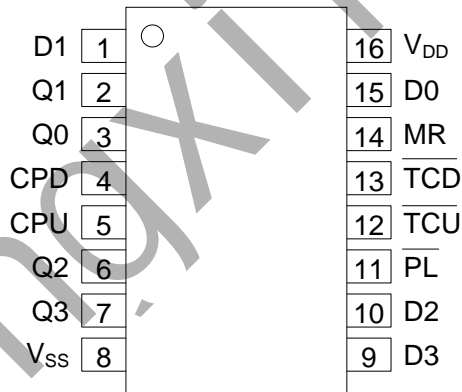

Figure 1. Functional diagram

2.2、Pin Configurations





2.3、Pin Description

Pin No.	Pin Name	Description
1	D1	parallel data input
2	Q1	buffered counter output
3	Q0	buffered counter output
4	CPD	count-down clock pulse input (LOW-to-HIGH, edge-triggered)
5	CPU	count-up clock pulse input (LOW-to-HIGH, edge-triggered)
6	Q2	buffered counter output
7	Q3	buffered counter output
8	V _{SS}	ground supply voltage
9	D3	parallel data input
10	D2	parallel data input
11	\overline{PL}	parallel load input (active low)
12	\overline{TCU}	buffered terminal count-up (carry) output (active LOW)
13	\overline{TCD}	buffered terminal count-down (borrow) output (active LOW)
14	MR	master reset input (asynchronous)
15	D0	parallel data input
16	V _{DD}	supply voltage

2.4、Function Table

MR	\overline{PL}	CPU	CPD	Mode
H	X	X	X	reset(asynchronous)
L	L	X	X	parallel load
L	H	↑	H	count-up
L	H	H	↑	count-down

Note: H=HIGH voltage level; L=LOW voltage level. X=don't care; ↑=positive-going transition;

3、Electrical Parameter

3.1、Absolute Maximum Ratings

(Voltages are referenced to V_{SS} (ground=0V), unless otherwise specified.)

Parameter	Symbol	Conditions	Min.	Max.	Unit
supply voltage	V _{DD}	-	-0.5	+18	V
input voltage	V _I	all inputs	-0.5	V _{DD} +0.5	V
DC input current	I _{IK}	any one input	-	±10	mA
storage temperature	T _{stg}	-	-65	+150	°C
soldering temperature	T _L	10s	DIP	245	°C
			SOP	260	



3.2、Recommended Operating Conditions

Parameter	Symbol	Conditions	Min.	Typ.	Max.	Unit
supply voltage	V_{DD}	-	3	-	15	V
ambient temperature	T_{amb}	in free air	-40	-	+125	°C

3.3、Electrical Characteristics

3.3.1、DC Characteristics 1

($T_{amb}=-40^{\circ}\text{C}$ to $+85^{\circ}\text{C}$, voltages are referenced to V_{SS} (ground=0V), unless otherwise specified.)

Parameter	Symbol	V_{DD}	Conditions	Min.	Typ.	Max.	Unit
HIGH-level input voltage	V_{IH}	5V	-	3.5	-	-	V
		10V	-	7	-	-	V
		15V	-	11	-	-	V
LOW-level input voltage	V_{IL}	5V	-	-	-	1.5	V
		10V	-	-	-	3	V
		15V	-	-	-	4	V
HIGH-level output voltage	V_{OH}	5V	$ I_O <1\mu\text{A}$	4.95	-	-	V
		10V	$ I_O <1\mu\text{A}$	9.95	-	-	V
		15V	$ I_O <1\mu\text{A}$	14.95	-	-	V
LOW-level output voltage	V_{OL}	5V	$ I_O <1\mu\text{A}$	-	-	0.05	V
		10V	$ I_O <1\mu\text{A}$	-	-	0.05	V
		15V	$ I_O <1\mu\text{A}$	-	-	0.05	V
HIGH-level output current	I_{OH}	5V	$V_O=4.6\text{V}$	-	-	-0.34	mA
		5V	$V_O=2.5\text{V}$	-	-	-1.3	mA
		10V	$V_O=9.5\text{V}$	-	-	-0.55	mA
		15V	$V_O=13.5\text{V}$	-	-	-1.65	mA
LOW-level output current	I_{OL}	5V	$V_O=0.4\text{V}$	0.34	-	-	mA
		10V	$V_O=0.5\text{V}$	0.46	-	-	mA
		15V	$V_O=1.5\text{V}$	1.4	-	-	mA
input leakage current	I_I	15V	$V_I=15\text{V}$ or GND	-	-	± 2	μA
supply current	I_{DD}	5V	$V_I=5\text{V}$ or GND; $I_O=0\text{A}$	-	-	7.5	μA
		10V	$V_I=10\text{V}$ or GND; $I_O=0\text{A}$	-	-	15	μA
		15V	$V_I=15\text{V}$ or GND; $I_O=0\text{A}$	-	-	30	μA



3.3.2、DC Characteristics 2

($T_{amb}=-40^{\circ}\text{C}$ to $+125^{\circ}\text{C}$, voltages are referenced to V_{SS} (ground=0V), unless otherwise specified.)

Parameter	Symbol	V_{DD}	Conditions	Min.	Typ.	Max.	Unit
HIGH-level input voltage	V_{IH}	5V	-	3.5	-	-	V
		10V	-	7	-	-	V
		15V	-	11	-	-	V
LOW-level input voltage	V_{IL}	5V	-	-	-	1.5	V
		10V	-	-	-	3	V
		15V	-	-	-	4	V
HIGH-level output voltage	V_{OH}	5V	$ I_O <1\mu\text{A}$	4.95	-	-	V
		10V	$ I_O <1\mu\text{A}$	9.95	-	-	V
		15V	$ I_O <1\mu\text{A}$	14.95	-	-	V
LOW-level output voltage	V_{OL}	5V	$ I_O <1\mu\text{A}$	-	-	0.05	V
		10V	$ I_O <1\mu\text{A}$	-	-	0.05	V
		15V	$ I_O <1\mu\text{A}$	-	-	0.05	V
HIGH-level output current	I_{OH}	5V	$V_O=4.6\text{V}$	-	-	-0.3	mA
		5V	$V_O=2.5\text{V}$	-	-	-1.15	mA
		10V	$V_O=9.5\text{V}$	-	-	-0.45	mA
		15V	$V_O=13.5\text{V}$	-	-	-1.4	mA
LOW-level output current	I_{OL}	5V	$V_O=0.4\text{V}$	0.29	-	-	mA
		10V	$V_O=0.5\text{V}$	0.38	-	-	mA
		15V	$V_O=1.5\text{V}$	1.2	-	-	mA
input leakage current	I_I	15V	$V_I=15\text{V}$ or GND	-	-	± 4	μA
supply current	I_{DD}	5V	$V_I=5\text{V}$ or GND; $I_O=0\text{A}$	-	-	7.5	μA
		10V	$V_I=10\text{V}$ or GND; $I_O=0\text{A}$	-	-	15	μA
		15V	$V_I=15\text{V}$ or GND; $I_O=0\text{A}$	-	-	30	μA

3.3.3、AC Characteristics 1

($T_{amb}=-40^{\circ}\text{C}$ to $+85^{\circ}\text{C}$, $V_{SS}=0\text{V}$, unless otherwise specified.)

Parameter	Symbol	V_{DD}	Conditions	Min.	Typ.	Max.	Unit
HIGH to LOW propagation delay time	t_{PHL}	5V	CPU to Qn See Figure 4	-	210	415	ns
		10V		-	85	165	ns
		15V		-	60	120	ns
		5V	CPD to Qn See Figure 4	-	210	425	ns
		10V		-	85	170	ns
		15V		-	60	125	ns
		5V	CPU to $\overline{\text{TCU}}$	-	125	250	ns
		10V		-	50	100	ns
		15V		-	35	70	ns
		5V	CPD to $\overline{\text{TCD}}$	-	140	280	ns
		10V		-	55	110	ns
		15V		-	40	80	ns
		5V	MR to Qn	-	195	390	ns
		10V		-	80	160	ns
		15V		-	60	120	ns



		5V	MR to $\overline{\text{TCD}}$	-	365	730	ns
		10V		-	130	265	ns
		15V		-	100	205	ns
		5V	$\overline{\text{PL}}$ to Qn	-	185	360	ns
		10V		-	75	150	ns
		15V		-	55	110	ns
LOW to HIGH propagation delay time	t_{PLH}	5V	CPU to Qn See Figure 4	-	170	340	ns
		10V		-	70	140	ns
		15V		-	50	100	ns
		5V	CPD to Qn See Figure 5	-	170	340	ns
		10V		-	70	140	ns
		15V		-	50	100	ns
		5V	CPU to $\overline{\text{TCU}}$	-	95	185	ns
		10V		-	40	80	ns
		15V		-	30	60	ns
		5V	CPD to $\overline{\text{TCD}}$	-	100	195	ns
		10V		-	40	85	ns
		15V		-	30	65	ns
		5V	MR to $\overline{\text{TCU}}$	-	145	285	ns
		10V		-	60	115	ns
		15V		-	45	90	ns
		5V	$\overline{\text{PL}}$ to Qn	-	145	290	ns
		10V		-	60	120	ns
		15V		-	45	90	ns
transition time	$t_{\text{THL}}, t_{\text{TLH}}$	5V	See Figure 4	-	60	120	ns
		10V		-	30	60	ns
		15V		-	20	40	ns
set-up time	t_{su}	5V	Dn to $\overline{\text{PL}}$	160	80	-	ns
		10V		60	30	-	ns
		15V		50	25	-	ns
hold time	t_{hold}	5V	Dn to $\overline{\text{PL}}$	+10	-70	-	ns
		10V		+5	-25	-	ns
		15V		+5	-20	-	ns
pulse width	t_{w}	5V	CPU or CPD LOW; minimum width	150	75	-	ns
		10V		50	25	-	ns
		15V		35	20	-	ns
		5V	MR input HIGH minimum width	180	90	-	ns
		10V		70	35	-	ns
		15V		60	30	-	ns
		5V	$\overline{\text{PL}}$ input LOW minimum width	120	60	-	ns
		10V		45	20	-	ns
		15V		30	15	-	ns
recovery time	t_{rec}	5V	MR input	125	65	-	ns
		10V		70	35	-	ns
		15V		50	25	-	ns
		5V	$\overline{\text{PL}}$ input	90	45	-	ns



		10V		35	15	-	ns
		15V		25	10	-	ns
maximum clock pulse frequency	fmax	5V	-	2.5	5	-	MHZ
		10V	-	7	14	-	MHZ
		15V	-	9	18	-	MHZ

3.3.4、AC Characteristics 2

($T_{amb}=-40^{\circ}\text{C}$ to $+125^{\circ}\text{C}$, $V_{SS}=0\text{V}$, unless otherwise specified.)

Parameter	Symbol	V _{DD}	Conditions	Min.	Typ.	Max.	Unit
HIGH to LOW propagation delay time	t _{PHL}	5V	CPU to Qn See Figure 4	-	-	498	ns
		10V		-	-	198	ns
		15V		-	-	144	ns
		5V	CPD to Qn See Figure 4	-	-	510	ns
		10V		-	-	204	ns
		15V		-	-	150	ns
		5V	CPU to $\overline{\text{TCU}}$	-	-	300	ns
		10V		-	-	120	ns
		15V		-	-	84	ns
		5V	CPD to $\overline{\text{TCD}}$	-	-	336	ns
		10V		-	-	132	ns
		15V		-	-	96	ns
		5V	MR to Qn	-	-	468	ns
		10V		-	-	192	ns
		15V		-	-	144	ns
		5V	MR to $\overline{\text{TCD}}$	-	-	876	ns
		10V		-	-	318	ns
		15V		-	-	246	ns
5V	$\overline{\text{PL}}$ to Qn	-	-	432	ns		
10V		-	-	180	ns		
15V		-	-	132	ns		
LOW to HIGH propagation delay time	t _{PLH}	5V	CPU to Qn See Figure 4	-	-	408	ns
		10V		-	-	168	ns
		15V		-	-	120	ns
		5V	CPD to Qn See Figure 5	-	-	408	ns
		10V		-	-	168	ns
		15V		-	-	120	ns
		5V	CPU to $\overline{\text{TCU}}$	-	-	222	ns
		10V		-	-	96	ns
		15V		-	-	72	ns
		5V	CPD to $\overline{\text{TCD}}$	-	-	234	ns
		10V		-	-	102	ns
		15V		-	-	78	ns
		5V	MR to $\overline{\text{TCU}}$	-	-	342	ns
		10V		-	-	138	ns
		15V		-	-	108	ns



		5V	$\overline{\text{PL}}$ to Qn	-	-	348	ns
		10V		-	-	144	ns
		15V		-	-	108	ns
transition time	$t_{\text{THL}}, t_{\text{TLH}}$	5V	See Figure 4	-	-	144	ns
		10V		-	-	72	ns
		15V		-	-	48	ns
set-up time	t_{su}	5V	Dn to $\overline{\text{PL}}$	192	-	-	ns
		10V		72	-	-	ns
		15V		60	-	-	ns
hold time	t_{hold}	5V	Dn to $\overline{\text{PL}}$	+12	-	-	ns
		10V		+6	-	-	ns
		15V		+6	-	-	ns
pulse width	t_{w}	5V	CPU or CPD LOW; minimum width	180	-	-	ns
		10V		60	-	-	ns
		15V		42	-	-	ns
		5V	MR input HIGH minimum width	216	-	-	ns
		10V		84	-	-	ns
		15V		72	-	-	ns
		5V	$\overline{\text{PL}}$ input LOW minimum width	144	-	-	ns
		10V		54	-	-	ns
		15V		36	-	-	ns
recovery time	t_{rec}	5V	MR input	150	-	-	ns
		10V		84	-	-	ns
		15V		60	-	-	ns
		5V	$\overline{\text{PL}}$ input	108	-	-	ns
		10V		42	-	-	ns
		15V		30	-	-	ns
maximum clock pulse frequency	f_{max}	5V	-	2	-	-	MHZ
		10V	-	6	-	-	MHZ
		15V	-	7.5	-	-	MHZ



4、Testing Circuit

4.1、AC Testing Circuit

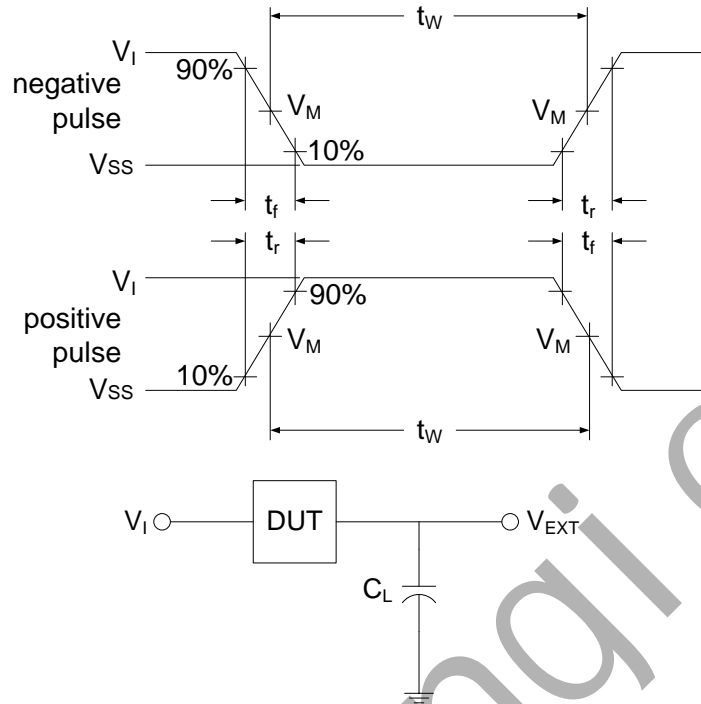

Figure 3. Load circuit

C_L includes probe and jig capacitance.

4.2、Test Data

Supply voltage	Input		Load	V_{EXT}		
V_{DD}	V_I	$t_r = t_f$	C_L	t_{PLH}/t_{PHL}	t_{PLZ}/t_{PZL}	t_{PHZ}/t_{PZH}
5V to 15V	V_{DD}	$\leq 20\text{ns}$	50pF	Open	V_{DD}	V_{SS}

4.3、AC Testing Waveforms

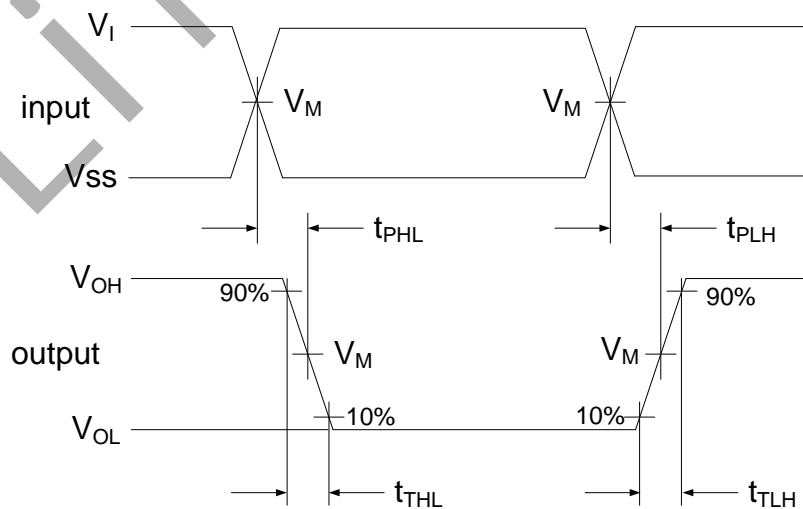

Figure 4. Propagation delay, output transition time

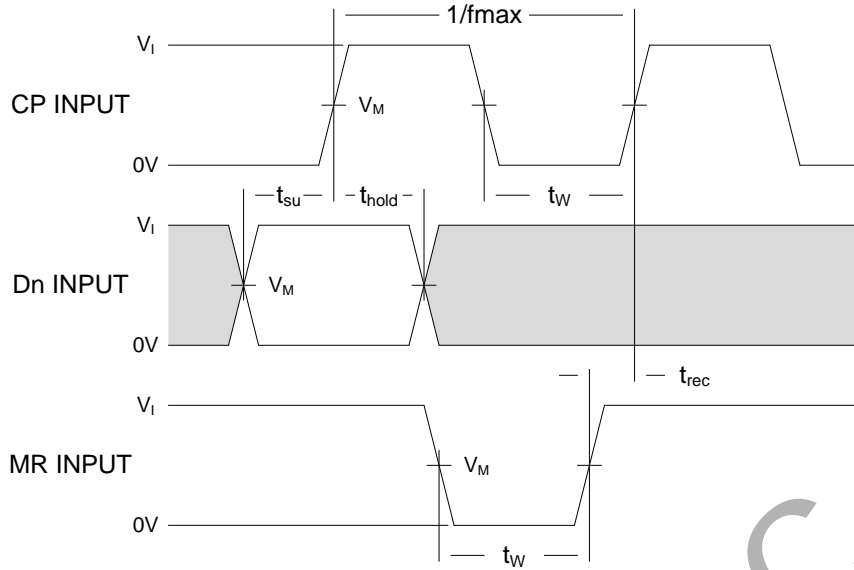

Figure 5. Minimum pulse widths for CP and MR, MR to CP recovery time, and set-up and hold time for Dn to CP

4.4、Measurement Points

Supply voltage	Input	Output		
V_{DD}	V_M	V_M	V_X	V_Y
5V to 15V	$0.5 \times V_{DD}$	$0.5 \times V_{DD}$	$0.1 \times V_{DD}$	$0.9 \times V_{DD}$



5、Package Information

5.1、DIP16

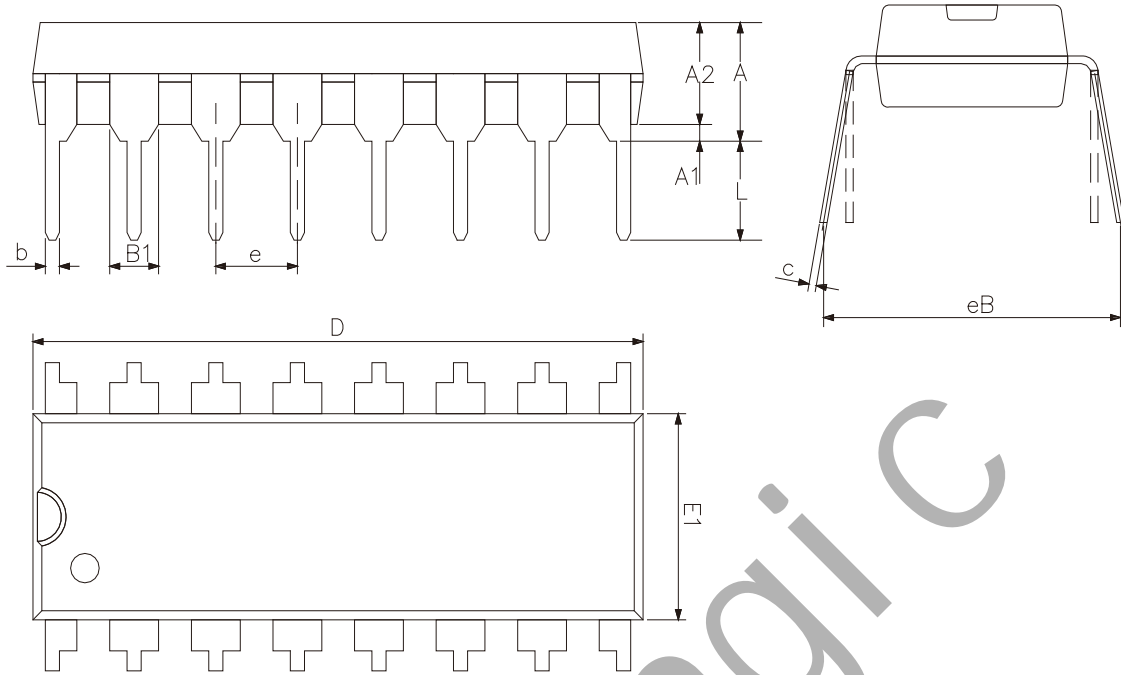

2023/12/A	Dimensions In Millimeters	
Symbol	Min	Max
A2	3.20	3.60
A1	0.51	—
A	3.60	5.33
L	3.00	—
b	0.36	0.56
B1	1.52	
D	18.80	19.94
E1	6.20	6.60
e	2.54	
c	0.20	0.36
eB	7.62	9.30



5.2、SOP16

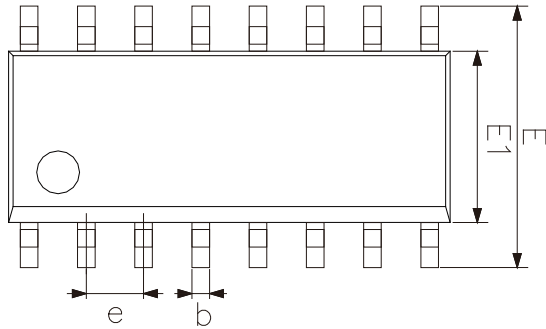
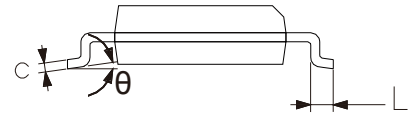
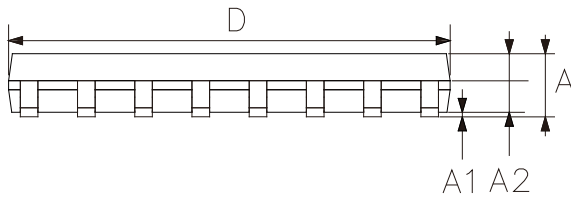

2023/12/A Symbol	Dimensions In Millimeters	
	Min.	Max.
A	1.35	1.80
A1	0.10	0.25
A2	1.25	1.55
b	0.33	0.51
c	0.19	0.25
D	9.50	10.10
E	5.80	6.30
E1	3.70	4.10
e	1.27	
L	0.35	0.89
θ	0°	8°



6、Statements And Notes

Recommended carefully reading this information before the use of this product;

The information in this document are subject to change without notice;

This information is using to the reference only, the company is not responsible for any loss;

The company is not responsible for the any infringement of the third party patents or other rights of the responsibility.

Lingxingic

X-ON Electronics

Largest Supplier of Electrical and Electronic Components

Click to view similar products for [Counter ICs](#) category:

Click to view products by [lingxingic](#) manufacturer:

Other Similar products are found below :

[CD4018BE](#) [CD4033BE](#) [CD4060BE](#) [CD4040BE](#) [NLV14040BDR2G](#) [RFDIP1607ALM9T21](#) [RFDIP1606L708D1T](#) [RFTIP2510T12A8Q1C](#)
[74HC161DT](#) [CD4028BM/TR](#) [CD4060DM/TR](#) [CD4022BE](#) [CD4060DMT/TR](#) [CD4060BMT/TR](#) [74HC192M/TR](#) [CD4020BMT/TR](#)
[74HC193M/TR](#) [CD4518BM/TR](#) [CD4060TA16.TB](#) [CD4060DE](#) [CD4017CN](#) [CD4017SA.TB](#) [CD4022BM/TR](#) [CD4022BMT/TR](#)
[CD4028BDRG](#) [CD4060BDRG](#) [CD4017DA.TB](#) [CD4520BDRG](#) [CD4520BM\(LX\)](#) [CD4518BM\(LX\)](#) [SN74HC393DR\(LX\)](#) [CD4060BM\(LX\)](#)
[CD4060BE\(LX\)](#) [SN74HC192N\(XBLW\)](#) [CD4040BM\(LX\)](#) [CD4026BM\(LX\)](#) [CD40103BDR\(LX\)](#) [SN74LS192DR\(LX\)](#) [SN74HC161DR \(LX\)](#)
[CD40193BE\(LX\)](#) [CD4060BDTR\(XBLW\)](#) [SN74LS393DR](#) [SN74LS193N\(LX\)](#) [SN74LS193DR\(LX\)](#) [CD4017BM\(LX\)](#) [CD40193BM\(LX\)](#)
[SN74LS192N\(LX\)](#) [SN74LS160N\(LX\)](#) [SN74LS161N\(LX\)](#) [CD4024BM\(LX\)](#)