



CD4024 (LX)

7-stage binary counter

Product Specification

Specification Revision History:

Version	Date	Description
2023-04-A1	2023-04	New



Contents

1、 General Description.....	3
2、 Block Diagram And Pin Description	4
2.1、 Block Diagram.....	4
2.2、 Pin Configurations	4
2.3、 Pin Description	4
2.4、 Function Table.....	5
3、 Electrical Parameter	5
3.1、 Absolute Maximum Ratings	5
3.2、 Recommended Operating Conditions	5
3.3、 Electrical Characteristics	5
3.3.1、 DC Characteristics 1	5
3.3.2、 DC Characteristics 2	6
3.3.3、 AC Characteristics 1	7
3.3.4、 AC Characteristics 2	8
4、 Testing Circuit	9
4.1、 AC Testing Circuit.....	9
4.2、 Test Data	9
4.3、 AC Testing Waveforms	9
4.4、 Measurement Points.....	10
5、 Package Information	11
5.1、 DIP14.....	11
5.2、 SOP14.....	12
5.3、 TSSOP14	13
6、 Statements And Notes	14
6.1、 The name and content of Hazardous substances or Elements in the product	14
6.2、 Notes.....	14



1、General Description

The CD4024 is a 7-stage binary ripple counter。

Features:

- Supply voltage range: 3V to 15V
- Temperature range: -40°C to +125°C
- Packaging information: DIP14/SOP14/TSSOP14

Ordering Information:

Tube packing specifications:

Part number	Packaging form	Marking code	Tube quantity	Boxed tube quantity	Boxed quantity	Notes
CD4024BE (LX)	DIP14	CD4024BE	25 PCS/tube	40 tube/box	1000 PCS/box	Dimensions of plastic enclosure: 19.0mm×6.4mm Pin spacing: 2.54mm
CD4024BM (LX)	SOP14	CD4024BM	50 PCS/tube	200 tube/box	10000 PCS/box	Dimensions of plastic enclosure: 8.7mm×3.9mm Pin spacing: 1.27mm
CD4024BPW(LX)	TSSOP14	CD4024	96 PCS/tube	200 tube/box	19200 PCS/box	Dimensions of plastic enclosure: 5.0mm×4.4mm Pin spacing: 0.65mm

Reel packing specifications:

Part number	Packaging form	Marking code	Reel quantity	Boxed reel quantity	Notes
CD4024BM(LX)	SOP14(1)	CD4024BM	2500 PCS/reel	5000 PCS/box	Dimensions of plastic enclosure: 8.7mm×3.9mm Pin spacing: 1.27mm
CD4024BM(LX)	SOP14(2)	CD4024BM	4000 PCS/reel	8000 PCS/box	Dimensions of plastic enclosure: 8.7mm×3.9mm Pin spacing: 1.27mm
CD4024BPW(LX)	TSSOP14	CD4024	5000 PCS/reel	10000 PCS/box	Dimensions of plastic enclosure: 5.0mm×4.4mm Pin spacing: 0.65mm

Note: If the physical information is inconsistent with the ordering information, please refer to the actual product.



2、Block Diagram And Pin Description

2.1、Block Diagram

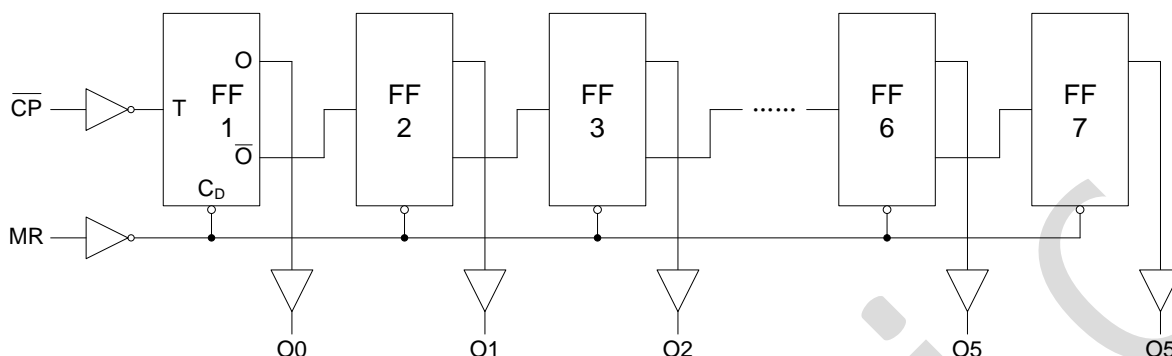
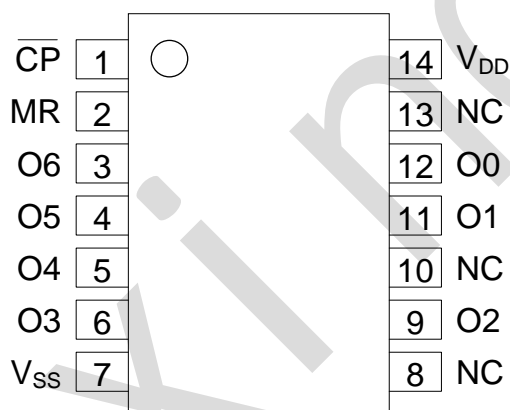

Figure 1. Functional diagram

2.2、Pin Configurations



2.3、Pin Description

Pin No.	Pin Name	Description
1	\overline{CP}	clock input
2	\overline{MR}	master reset output
3	O6	buffered parallel output
4	O5	buffered parallel output
5	O4	buffered parallel output
6	O3	buffered parallel output
7	V _{SS}	ground supply voltage
8	NC	not connected
9	O2	buffered parallel output
10	NC	not connected
11	O1	buffered parallel output
12	O0	buffered parallel output
13	NC	not connected
14	V _{DD}	supply voltage



2.4、Function Table

Input		Output
\overline{CP}	MR	On
X	H	L
↑	L	No Change
↓	L	Advance to Next State

Note: H=HIGH voltage level; L=LOW voltage level.

3、Electrical Parameter

3.1、Absolute Maximum Ratings

(Voltages are referenced to V_{SS} (ground=0V), unless otherwise specified.)

Parameter	Symbol	Conditions	Min.	Max.	Unit
supply voltage	V_{DD}	-	-0.5	+18	V
input voltage	V_I	all inputs	-0.5	$V_{DD}+0.5$	V
DC input current	I_{IK}	any one input	-	±10	mA
storage temperature	T_{stg}	-	-65	+150	°C
soldering temperature	T_L	10s	DIP	245	°C
			SOP/TSSOP	260	

3.2、Recommended Operating Conditions

Parameter	Symbol	Conditions	Min.	Typ.	Max.	Unit
supply voltage	V_{DD}	-	3	-	15	V
ambient temperature	T_{amb}	in free air	-40	-	+125	°C

3.3、Electrical Characteristics

3.3.1、DC Characteristics 1

($T_{amb}=-40^{\circ}C$ to $+85^{\circ}C$, voltages are referenced to V_{SS} (ground=0V), unless otherwise specified.)

Parameter	Symbol	V_{DD}	Conditions	Min.	Typ.	Max.	Unit
HIGH-level input voltage	V_{IH}	5V	-	3.5	-	-	V
		10V	-	7	-	-	V
		15V	-	11	-	-	V
LOW-level input voltage	V_{IL}	5V	-	-	-	1.5	V
		10V	-	-	-	3	V
		15V	-	-	-	4	V
HIGH-level output voltage	V_{OH}	5V	$ I_O <1\mu A$	4.95	-	-	V
		10V	$ I_O <1\mu A$	9.95	-	-	V
		15V	$ I_O <1\mu A$	14.95	-	-	V
LOW-level output voltage	V_{OL}	5V	$ I_O <1\mu A$	-	-	0.05	V
		10V	$ I_O <1\mu A$	-	-	0.05	V
		15V	$ I_O <1\mu A$	-	-	0.05	V
HIGH-level output current	I_{OH}	5V	$V_O=4.6V$	-	-	-0.34	mA
		5V	$V_O=2.5V$	-	-	-1.3	mA
		10V	$V_O=9.5V$	-	-	-0.55	mA
		15V	$V_O=13.5V$	-	-	-1.65	mA



LOW-level output current	I _{OL}	5V	V _O =0.4V	0.34	-	-	mA
		10V	V _O =0.5V	0.46	-	-	mA
		15V	V _O =1.5V	1.4	-	-	mA
input leakage current	I _I	15V	V _I =15V or GND	-	-	±2	uA
supply current	I _{DD}	5V	V _I =5V or GND; I _O =0A	-	-	7.5	uA
		10V	V _I =10V or GND; I _O =0A	-	-	15	uA
		15V	V _I =15V or GND; I _O =0A	-	-	30	uA

3.3.2、DC Characteristics 2

(T_{amb}=-40°C to +125°C, voltages are referenced to V_{SS} (ground=0V), unless otherwise specified.)

Parameter	Symbol	V _{DD}	Conditions	Min.	Typ.	Max.	Unit
HIGH-level input voltage	V _{IH}	5V	-	3.5	-	-	V
		10V	-	7	-	-	V
		15V	-	11	-	-	V
LOW-level input voltage	V _{IL}	5V	-	-	-	1.5	V
		10V	-	-	-	3	V
		15V	-	-	-	4	V
HIGH-level output voltage	V _{OH}	5V	I _O <1uA	4.95	-	-	V
		10V	I _O <1uA	9.95	-	-	V
		15V	I _O <1uA	14.95	-	-	V
LOW-level output voltage	V _{OL}	5V	I _O <1uA	-	-	0.05	V
		10V	I _O <1uA	-	-	0.05	V
		15V	I _O <1uA	-	-	0.05	V
HIGH-level output current	I _{OH}	5V	V _O =4.6V	-	-	-0.3	mA
		5V	V _O =2.5V	-	-	-1.15	mA
		10V	V _O =9.5V	-	-	-0.45	mA
		15V	V _O =13.5V	-	-	-1.4	mA
LOW-level output current	I _{OL}	5V	V _O =0.4V	0.29	-	-	mA
		10V	V _O =0.5V	0.38	-	-	mA
		15V	V _O =1.5V	1.2	-	-	mA
input leakage current	I _I	15V	V _I =15V or GND	-	-	±4	uA
supply current	I _{DD}	5V	V _I =5V or GND; I _O =0A	-	-	7.5	uA
		10V	V _I =10V or GND; I _O =0A	-	-	15	uA
		15V	V _I =15V or GND; I _O =0A	-	-	30	uA



3.3.3、AC Characteristics 1

($T_{amb} = -40^{\circ}C$ to $+85^{\circ}C$, $V_{SS} = 0V$, unless otherwise specified.)

Parameter	Symbol	V _{DD}	Conditions	Min.	Typ.	Max.	Unit
On to O _{n+1} HIGH to LOW propagation delay time	t _{PHL}	5V	C _L =50pF see Figure 4	-	60	120	ns
		10V		-	25	50	ns
		15V		-	20	40	ns
On to O _{n+1} LOW to HIGH propagation delay time	t _{PLH}	5V		-	50	100	ns
		10V		-	20	40	ns
		15V		-	15	30	ns
\overline{CP} to O0 HIGH to LOW propagation delay time	t _{PHL}	5V		-	100	200	ns
		10V		-	40	75	ns
		15V		-	25	50	ns
\overline{CP} to O0 LOW to HIGH propagation delay time	t _{PLH}	5V		-	105	210	ns
		10V		-	45	85	ns
		15V		-	30	60	ns
MR to Qn HIGH to LOW propagation delay time	t _{PHL}	5V	-	120	240	ns	
		10V	-	45	90	ns	
		15V	-	30	60	ns	
transition time	t _{THL} , t _{TLH}	5V	-	60	120	ns	
		10V	-	30	60	ns	
		15V	-	20	40	ns	
Minimum clock pulse width;HIGH	t _{WCPH}	5V	60	120	-	ns	
		10V	30	60	-	ns	
		15V	20	40	-	ns	
Minimum MR pulse width;HIGH	t _{WMRH}	5V	80	40	-	ns	
		10V	35	20	-	ns	
		15V	25	15	-	ns	
Recovery time for MR	t _{RMR}	5V	20	10	-	ns	
		10V	15	5	-	ns	
		15V	15	5	-	ns	
Maximum clock pulse frequency	f _{max}	5V	-	5	10	-	MHZ
		10V	-	13	25	-	MHZ
		15V	-	18	35	-	MHZ



3.3.4、AC Characteristics 2

($T_{amb} = -40^{\circ}C$ to $+125^{\circ}C$, $V_{SS} = 0V$, unless otherwise specified.)

Parameter	Symbol	V _{DD}	Conditions	Min.	Typ.	Max.	Unit
On to O _{n+1} HIGH to LOW propagation delay time	t _{PHL}	5V	C _L =50pF, see Figure 4	-	-	144	ns
		10V		-	-	60	ns
		15V		-	-	48	ns
On to O _{n+1} LOW to HIGH propagation delay time	t _{PLH}	5V		-	-	120	ns
		10V		-	-	48	ns
		15V		-	-	36	ns
\overline{CP} to O0 HIGH to LOW propagation delay time	t _{PHL}	5V		-	-	240	ns
		10V		-	-	90	ns
		15V		-	-	60	ns
\overline{CP} to O0 LOW to HIGH propagation delay time	t _{PLH}	5V		-	-	252	ns
		10V		-	-	102	ns
		15V		-	-	72	ns
MR to Qn HIGH to LOW propagation delay time	t _{PHL}	5V	-	-	288	ns	
		10V	-	-	108	ns	
		15V	-	-	72	ns	
transition time	t _{THL} , t _{TLH}	5V	-	-	144	ns	
		10V	-	-	72	ns	
		15V	-	-	48	ns	
Minimum clock pulse width;HIGH	t _{WCPH}	5V	72	-	-	ns	
		10V	36	-	-	ns	
		15V	24	-	-	ns	
Minimum MR pulse width;HIGH	t _{WMRH}	5V	96	-	-	ns	
		10V	42	-	-	ns	
		15V	30	-	-	ns	
Recovery time for MR	t _{RMR}	5V	36	-	-	ns	
		10V	18	-	-	ns	
		15V	18	-	-	ns	
Maximum clock pulse frequency	f _{max}	5V	-	4	-	MHZ	
		10V	-	12	-	MHZ	
		15V	-	17	-	MHZ	



4、Testing Circuit

4.1、AC Testing Circuit

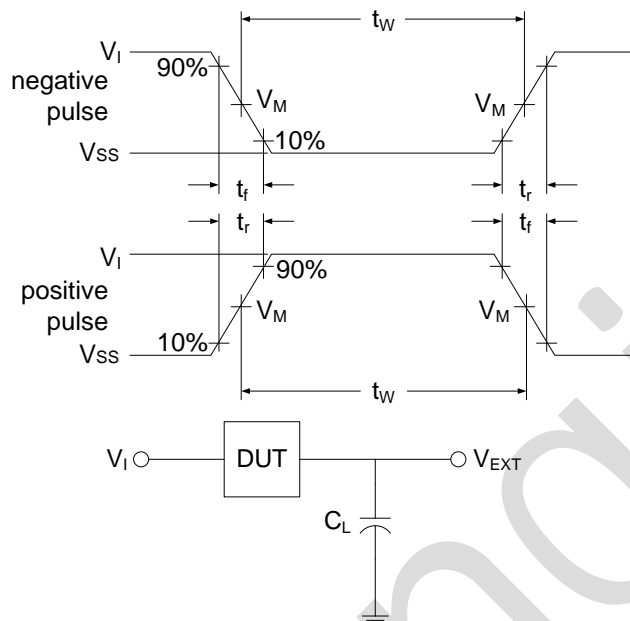

Figure 3. Load circuit

C_L includes probe and jig capacitance.

4.2、Test Data

Supply voltage	Input		Load	V_{EXT}		
V_{DD}	V_I	$t_r = t_f$	C_L	t_{PLH}/t_{PHL}	t_{PLZ}/t_{PZL}	t_{PHZ}/t_{PZH}
5V to 15V	V_{DD}	$\leq 20\text{ns}$	50pF	Open	V_{DD}	V_{SS}

4.3、AC Testing Waveforms

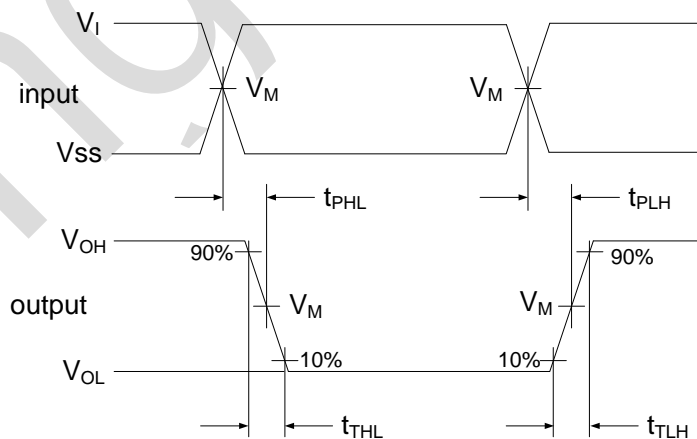

Figure 4. Propagation delay, output transition time

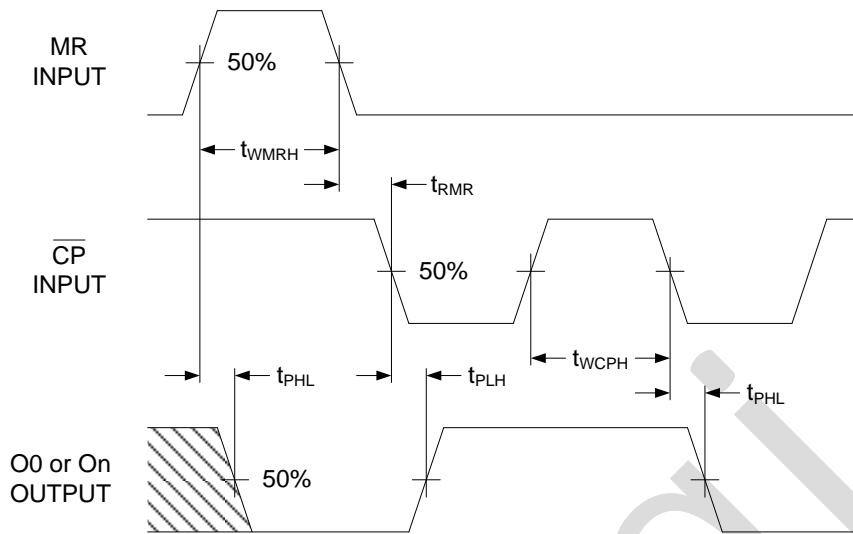

Figure 5. Waveforms showing minimum MR and \overline{CP} pulse widths and recovery time for MR.

4.4. Measurement Points

Supply voltage	Input	Output		
V_{DD}	V_M	V_M	V_X	V_Y
5V to 15V	$0.5 \times V_{DD}$	$0.5 \times V_{DD}$	$0.1 \times V_{DD}$	$0.9 \times V_{DD}$



5、Package Information

5.1、DIP14

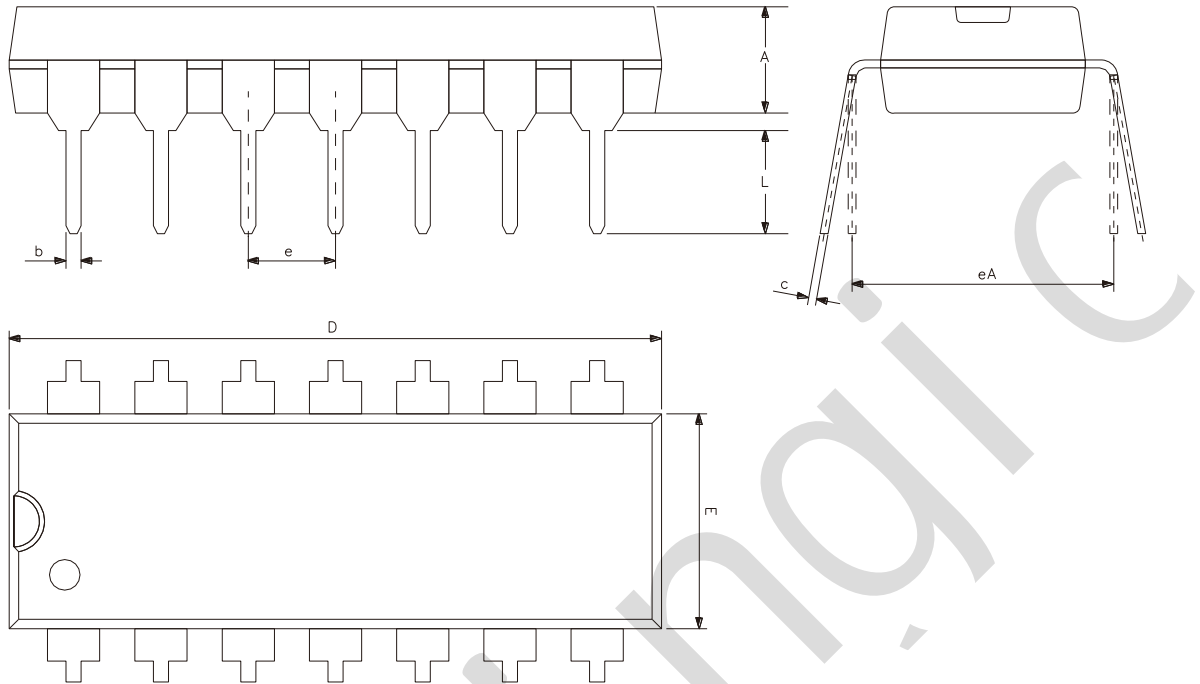

Symbol	Dimensions (mm)	
	Min.	Max.
A	3.05	3.60
b	0.33	0.56
c	0.20	0.36
D	18.80	19.40
E	6.20	6.60
e	2.54	
eA	7.62	10.90
L	2.92	-



5.2、SOP14

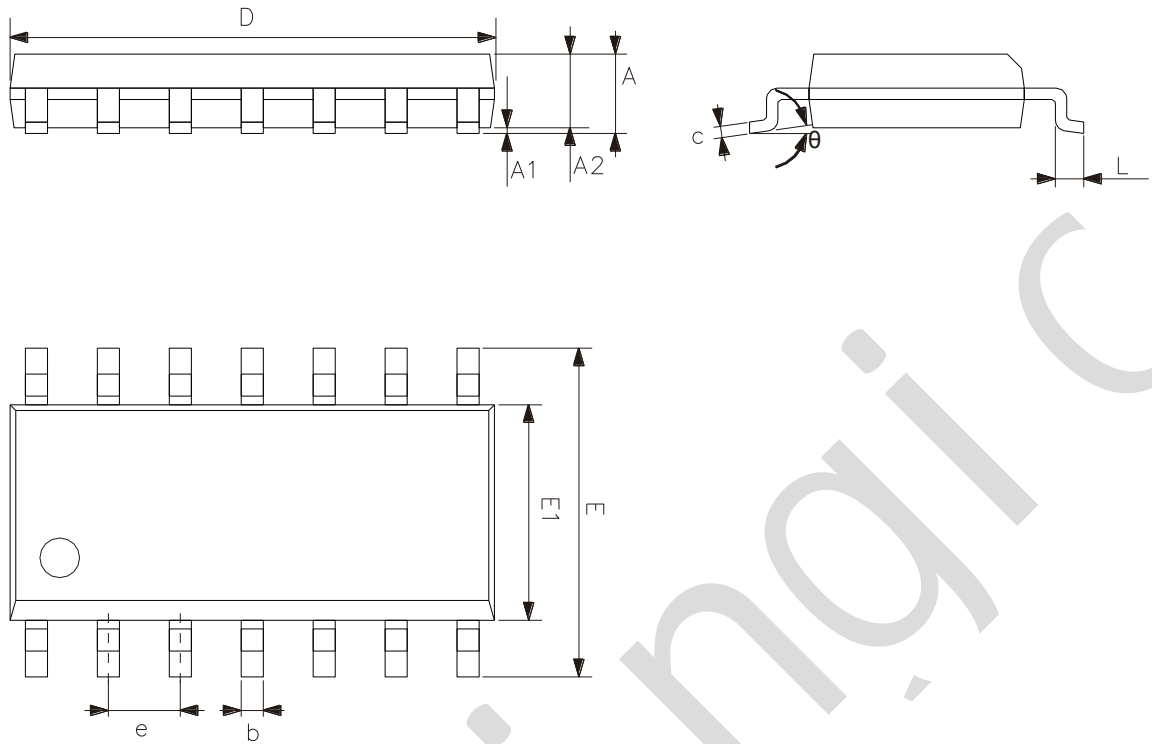

Symbol	Dimensions (mm)	
	Min.	Max.
A	1.50	1.75
A1	0.05	0.25
A2	1.30	-
b	0.33	0.50
c	0.19	0.25
D	8.43	8.76
E	5.80	6.25
E1	3.75	4.00
e	1.27	
L	0.40	0.89
θ	0°	8°



5.3、TSSOP14

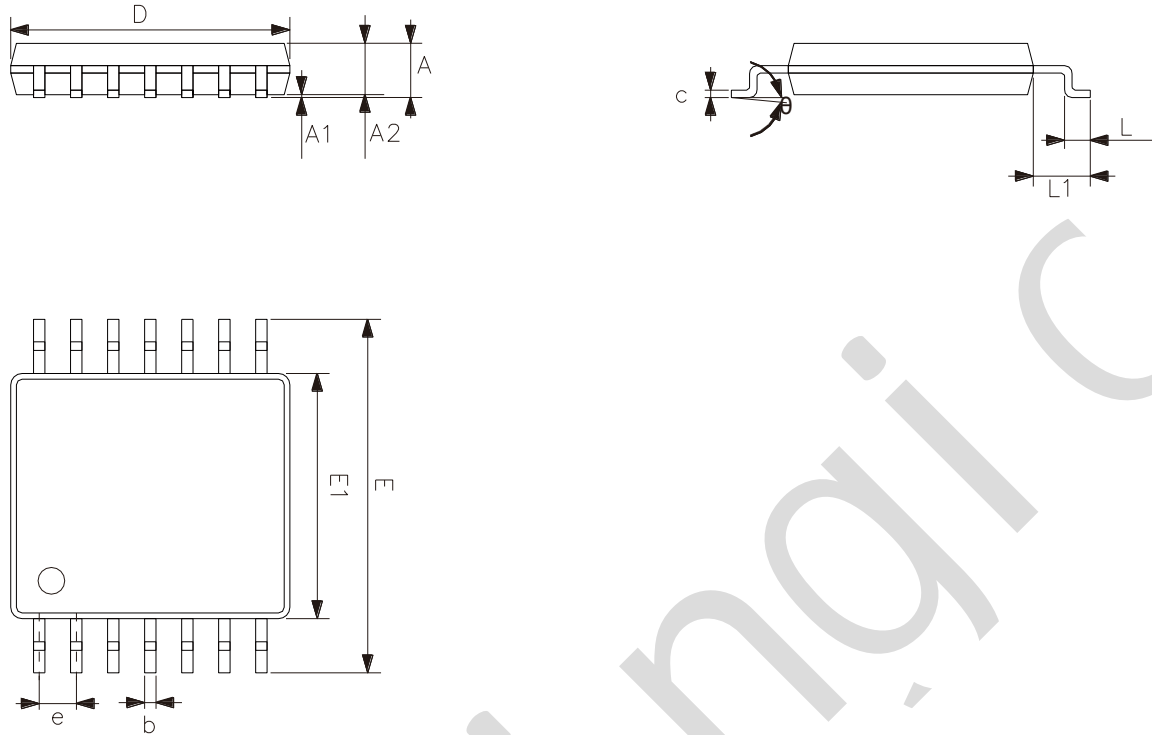

Symbol	Dimensions (mm)	
	Min.	Max.
A	-	1.20
A1	0.05	0.15
A2	0.80	1.05
b	0.19	0.30
c	0.09	0.20
D	4.90	5.10
E1	4.30	4.50
E	6.20	6.60
e	0.65	
L	0.45	0.75
L1	1.00	
θ	0°	8°



6、 Statements And Notes

6.1、 The name and content of Hazardous substances or Elements in the product

Part name	Hazardous substances or Elements									
	Lead and lead compounds	Mercury and mercury compounds	Cadmium and cadmium compounds	Hexavalent chromium compounds	Polybrominated biphenyls	Polybrominated biphenyl ethers	Dibutyl phthalate	Butylbenzyl phthalate	Di-2-ethylhexyl phthalate	Diisobutyl phthalate
Lead frame	○	○	○	○	○	○	○	○	○	○
Plastic resin	○	○	○	○	○	○	○	○	○	○
Chip	○	○	○	○	○	○	○	○	○	○
The lead	○	○	○	○	○	○	○	○	○	○
Plastic sheet installed	○	○	○	○	○	○	○	○	○	○
explanation	○: Indicates that the content of hazardous substances or elements in the detection limit of the following the SJ/T11363-2006 standard. ×: Indicates that the content of hazardous substances or elements exceeding the SJ/T11363-2006 Standard limit requirements.									

6.2、 Notes

We recommend you to read this chapter carefully before using this product.

The information in this chapter is provided for reference only and lingxing disclaims any express or implied warranties, including but not limited to applicability, special application or non-infringement of third party rights.

This product is not suitable for critical equipment such as life-saving, life-sustaining or safety equipment. It is also not suitable for applications that may result in personal injury, death, or serious property or environmental damage due to product malfunction or failure. Lingxing will not be liable for any damages incurred by the customers at their own risk for such applications.

The customer is responsible for conducting all necessary tests lingxing's application to avoid failure in the application or the application of the customer's third party users. Lingxing does not accept any liability.

The Company reserves the right to change or improve the information published in this chapter at any time. The information in this chapter are subject to change without notice. We recommend the customer to consult our sales staff before purchasing.

Please obtain related materials form lingxing's regular channels and we are not responsible for its content if it is provided by sources other than our company.

In case of any conflict between the Chinese and English version, the version is subject to the Chinese one.

X-ON Electronics

Largest Supplier of Electrical and Electronic Components

Click to view similar products for [Counter ICs](#) category:

Click to view products by [lingxingic](#) manufacturer:

Other Similar products are found below :

[CD4018BE](#) [CD4033BE](#) [CD4060BE](#) [CD4040BE](#) [NLV14040BDR2G](#) [RFDIP1607ALM9T21](#) [RFDIP1606L708D1T](#) [RFTIP2510T12A8Q1C](#)
[74HC161DT](#) [CD4028BM/TR](#) [CD4060DM/TR](#) [CD4022BE](#) [CD4060DMT/TR](#) [CD4020BE](#) [CD4060BMT/TR](#) [74HC192M/TR](#)
[CD4020BMT/TR](#) [CD4017CMT/TR](#) [74HC193M/TR](#) [CD4017CM/TR](#) [AiP74HC193SA16.TB](#) [CD4518BM/TR](#) [CD4060TA16.TB](#) [CD4060DE](#)
[CD4017CN](#) [CD4017BMT/TR](#) [U74HC4060G-S16-R](#) [CD4017SA.TB](#) [XD74LS160](#) [CD4017BM-MS](#) [CD4022BM/TR](#) [CD4022BMT/TR](#)
[CD4028BDRG](#) [CD4060BDRG](#) [CD4017DA.TB](#) [CD4520BDRG](#) [CD4520BM\(LX\)](#) [CD4518BM\(LX\)](#) [SN74HC393DR\(LX\)](#) [SN74HC393N\(LX\)](#)
[CD4060BM\(LX\)](#) [CD4060BE\(LX\)](#) [CD4518BE\(LX\)](#) [CD4520BE\(LX\)](#) [SN74HC192N\(XBLW\)](#) [CD4040BM\(LX\)](#) [CD4026BM\(LX\)](#)
[CD40103BDR\(LX\)](#) [SN74LS192DR\(LX\)](#) [SN74HC161DR \(LX\)](#)