



# CD4026 (LX) CMOS Decode Counters/Dividers

## Product Specification

### Specification Revision History:

Version	Date	Description
2023-04-A1	2023-04	New



灵星芯微 芯片经营

# Contents

<b>1、 General Description.....</b>	<b>3</b>
<b>2、 Block Diagram And Pin Description .....</b>	<b>4</b>
2.1、 Block Diagram .....	4
2.2、 Pin Configurations.....	4
2.3、 Pin Description.....	5
2.4、 Function Table.....	5
<b>3、 Electrical Parameter .....</b>	<b>6</b>
3.1、 Absolute Maximum Ratings.....	6
3.2、 Recommended Operating Conditions .....	6
3.3、 Electrical Characteristics .....	6
3.3.1、 DC Characteristics 1 .....	6
3.3.2、 DC Characteristics 2.....	7
3.3.3、 AC Characteristics 1 .....	8
3.3.4、 AC Characteristics 2.....	9
<b>4、 Testing Circuit .....</b>	<b>10</b>
4.1、 AC Testing Circuit .....	10
4.2、 Test Data .....	10
4.3、 AC Testing Waveforms.....	11
4.4、 Measurement Points .....	11
<b>5、 Package Information .....</b>	<b>12</b>
5.1、 DIP16 .....	12
5.2、 SOP16 .....	13
5.3、 TSSOP16.....	14
<b>6、 Statements And Notes .....</b>	<b>15</b>
6.1、 The name and content of Hazardous substances or Elements in the product.....	15



## 1、 General Description

The CD4026 is a CMOS decade.counter/divider.

### Features:

- Supply voltage range:3V to 15V
- Temperature range:-40℃ to +125℃
- Packaging information: DIP16/SOP16/TSSOP16

### Ordering Information:

#### Tube packing specifications:

Part number	Packaging form	Marking code	Tube quantity	Boxed tube quantity	Boxed quantity	Notes
CD4026BE(LX)	DIP16	CD4026BE	25 PCS/tube	40 tube/box	1000 PCS/box	Dimensions of plastic enclosure: 19.0mm×6.4mm Pin spacing:2.54mm
CD4026BM(LX)	SOP16	CD4026BM	50 PCS/tube	200 tube/box	10000 PCS/box	Dimensions of plastic enclosure: 10.0mm×3.9mm Pin spacing:1.27mm
CD4026BPW(LX)	TSSOP16	CD4026BPW	96 PCS/tube	200 tube/box	19200 PCS/box	Dimensions of plastic enclosure: 5.0mm×4.4mm Pin spacing:0.65mm

#### Reel packing specifications:

Part number	Packaging form	Marking code	Reel quantity	Boxed reel quantity	Notes
CD4026BM(LX)	SOP16(1)	CD4026BM	2500PCS/reel	5000PCS/box	Dimensions of plastic enclosure: 10.0mm×3.9mm Pin spacing:1.27mm
CD4026BM(LX)	SOP16(2)	CD4026BM	4000PCS/reel	8000PCS/box	Dimensions of plastic enclosure: 10.0mm×3.9mm Pin spacing:1.27mm
CD4026BPW(LX)	TSSOP16	CD4026BPW	5000PCS/reel	10000PCS/box	Dimensions of plastic enclosure: 5.0mm×4.4mm Pin spacing:0.65mm

Note: If the physical information is inconsistent with the ordering information, please refer to the actual product.



## 2、Block Diagram And Pin Description

### 2.1、Block Diagram

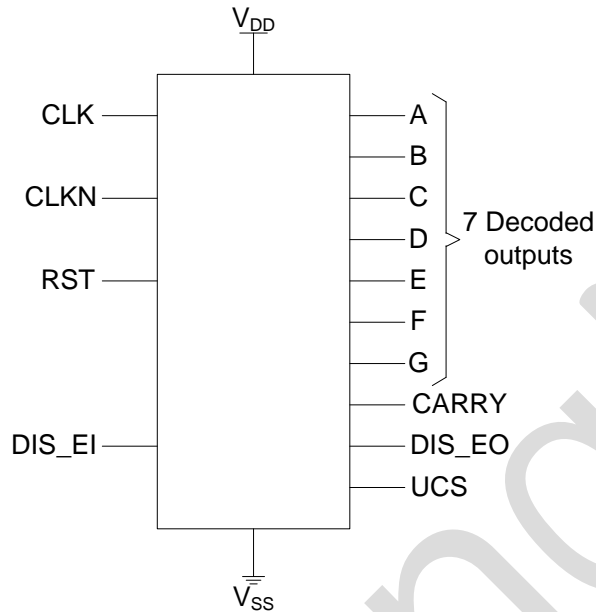
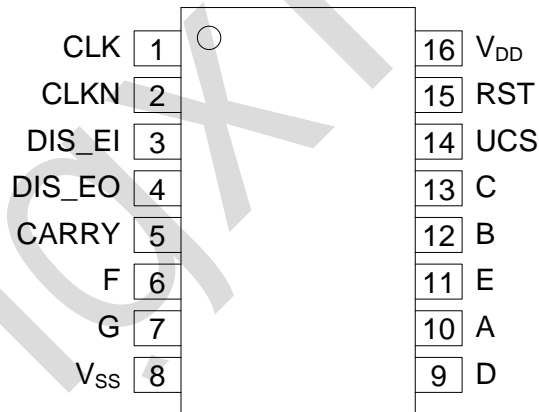

Figure 1. Functional diagram

### 2.2、Pin Configurations





2.3、Pin Description

Pin No.	Pin Name	Description
1	CLK	clock input
2	CLKN	clock inhibit input
3	DIS_EI	display enable input
4	DIS_EO	display enable output
5	CARRY	carry output
6	F	segment output
7	G	segment output
8	V <sub>SS</sub>	ground supply voltage
9	D	segment output
10	A	segment output
11	E	segment output
12	B	segment output
13	C	segment output
14	UCS	ungated C segment output
15	RST	reset
16	V <sub>DD</sub>	supply voltage

2.4、Function Table

Inputs				Outputs									Display	
CLK	CLKN	DIS_EI	RST	a	b	c	d	e	f	g	DIS_EO	CARRY		UCS
X	X	H	H	H	H	H	H	H	H	L	H	H	H	0
X	X	L	X	L	L	L	L	L	L	L	L	H	H	blank
↑	L	H	L	H	H	H	H	H	H	L	H	H	H	0
↑	L	H	L	L	H	H	L	L	L	L	H	H	H	1
↑	L	H	L	H	H	L	H	H	L	H	H	H	L	2
↑	L	H	L	H	H	H	H	L	L	H	H	H	H	3
↑	L	H	L	L	H	H	L	L	H	H	H	H	H	4
↑	L	H	L	H	L	H	H	L	H	H	H	L	H	5
↑	L	H	L	H	L	H	H	H	H	H	H	L	H	6
↑	L	H	L	H	H	H	L	L	L	L	H	L	H	7
↑	L	H	L	H	H	H	H	H	H	H	H	L	H	8
↑	L	H	L	H	H	H	H	L	H	H	H	L	H	9
H	↓	H	L	H	H	H	H	H	H	L	H	H	H	0
H	↓	H	L	L	H	H	L	L	L	L	H	H	H	1
H	↓	H	L	H	H	L	H	H	L	H	H	H	L	2
H	↓	H	L	H	H	H	H	L	L	H	H	H	H	3
H	↓	H	L	L	H	H	L	L	H	H	H	H	H	4
H	↓	H	L	H	L	H	H	L	H	H	H	L	H	5
H	↓	H	L	H	L	H	H	H	H	H	H	L	H	6
H	↓	H	L	H	H	H	L	L	L	L	H	L	H	7
H	↓	H	L	H	H	H	H	H	H	H	H	L	H	8
H	↓	H	L	H	H	H	H	L	H	H	H	L	H	9
X	H	H	L	NC							H	NC	NC	NC



L	X	H	L	NC	H	NC	NC	NC
---	---	---	---	----	---	----	----	----

Note: H=HIGH voltage level; L=LOW voltage level. X=don't care.NC=no change.

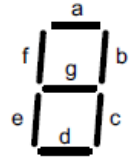
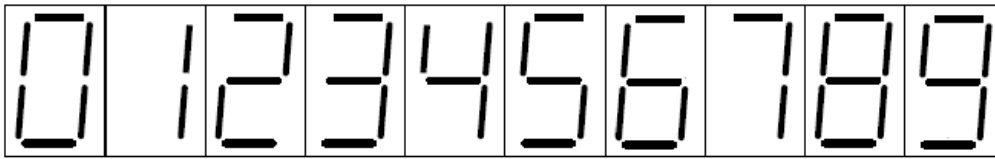

### 3、Electrical Parameter

#### 3.1、Absolute Maximum Ratings

(Voltages are referenced to  $V_{SS}$  (ground=0V), unless otherwise specified.)

Parameter	Symbol	Conditions	Min.	Max.	Unit
supply voltage	$V_{DD}$	-	-0.5	+18	V
input voltage	$V_I$	all inputs	-0.5	$V_{DD}+0.5$	V
DC input current	$I_{IK}$	any one input	-	$\pm 10$	mA
storage temperature	$T_{stg}$	-	-65	+150	$^{\circ}C$
soldering temperature	$T_L$	10s	DIP	245	$^{\circ}C$
			SOP/TSSOP	260	

#### 3.2、Recommended Operating Conditions

Parameter	Symbol	Conditions	Min.	Typ.	Max.	Unit
supply voltage	$V_{DD}$	-	3	-	15	V
ambient temperature	$T_{amb}$	in free air	-40	-	+125	$^{\circ}C$

#### 3.3、Electrical Characteristics

##### 3.3.1、DC Characteristics 1

( $T_{amb}=-40^{\circ}C$  to  $+85^{\circ}C$ , voltages are referenced to  $V_{SS}$  (ground=0V), unless otherwise specified.)

Parameter	Symbol	$V_{DD}$	Conditions	Min.	Typ.	Max.	Unit
HIGH-level input voltage	$V_{IH}$	5V	-	3.5	-	-	V
		10V	-	7	-	-	V
		15V	-	11	-	-	V
LOW-level input voltage	$V_{IL}$	5V	-	-	-	1.5	V
		10V	-	-	-	3	V
		15V	-	-	-	4	V
HIGH-level output voltage	$V_{OH}$	5V	$ I_O  < 1\mu A$	4.95	-	-	V
		10V	$ I_O  < 1\mu A$	9.95	-	-	V
		15V	$ I_O  < 1\mu A$	14.95	-	-	V
LOW-level output voltage	$V_{OL}$	5V	$ I_O  < 1\mu A$	-	-	0.05	V
		10V	$ I_O  < 1\mu A$	-	-	0.05	V
		15V	$ I_O  < 1\mu A$	-	-	0.05	V
HIGH-level output current	$I_{OH}$	5V	$V_O=4.6V$	-	-	-0.34	mA
		5V	$V_O=2.5V$	-	-	-1.3	mA
		10V	$V_O=9.5V$	-	-	-0.55	mA
		15V	$V_O=13.5V$	-	-	-1.65	mA



LOW-level output current	$I_{OL}$	5V	$V_O=0.4V$	0.34	-	-	mA
		10V	$V_O=0.5V$	0.46	-	-	mA
		15V	$V_O=1.5V$	1.4	-	-	mA
input leakage current	$I_I$	15V	$V_I=15V$ or GND	-	-	$\pm 2$	$\mu A$
supply current	$I_{DD}$	5V	$V_I=5V$ or GND; $I_O=0A$	-	-	7.5	$\mu A$
		10V	$V_I=10V$ or GND; $I_O=0A$	-	-	15	$\mu A$
		15V	$V_I=15V$ or GND; $I_O=0A$	-	-	30	$\mu A$

### 3.3.2、DC Characteristics 2

( $T_{amb}=-40^{\circ}C$  to  $+125^{\circ}C$ , voltages are referenced to  $V_{SS}$  (ground=0V), unless otherwise specified.)

Parameter	Symbol	$V_{DD}$	Conditions	Min.	Typ.	Max.	Unit
HIGH-level input voltage	$V_{IH}$	5V	-	3.5	-	-	V
		10V	-	7	-	-	V
		15V	-	11	-	-	V
LOW-level input voltage	$V_{IL}$	5V	-	-	-	1.5	V
		10V	-	-	-	3	V
		15V	-	-	-	4	V
HIGH-level output voltage	$V_{OH}$	5V	$ I_O <1\mu A$	4.95	-	-	V
		10V	$ I_O <1\mu A$	9.95	-	-	V
		15V	$ I_O <1\mu A$	14.95	-	-	V
LOW-level output voltage	$V_{OL}$	5V	$ I_O <1\mu A$	-	-	0.05	V
		10V	$ I_O <1\mu A$	-	-	0.05	V
		15V	$ I_O <1\mu A$	-	-	0.05	V
HIGH-level output current	$I_{OH}$	5V	$V_O=4.6V$	-	-	-0.3	mA
		5V	$V_O=2.5V$	-	-	-1.15	mA
		10V	$V_O=9.5V$	-	-	-0.45	mA
		15V	$V_O=13.5V$	-	-	-1.4	mA
LOW-level output current	$I_{OL}$	5V	$V_O=0.4V$	0.29	-	-	mA
		10V	$V_O=0.5V$	0.38	-	-	mA
		15V	$V_O=1.5V$	1.2	-	-	mA
input leakage current	$I_I$	15V	$V_I=15V$ or GND	-	-	$\pm 4$	$\mu A$
supply current	$I_{DD}$	5V	$V_I=5V$ or GND; $I_O=0A$	-	-	7.5	$\mu A$
		10V	$V_I=10V$ or GND; $I_O=0A$	-	-	15	$\mu A$
		15V	$V_I=15V$ or GND; $I_O=0A$	-	-	30	$\mu A$



**3.3.3、AC Characteristics 1**

( $T_{amb} = -40^{\circ}\text{C}$  to  $+85^{\circ}\text{C}$ ,  $V_{SS} = 0\text{V}$ , unless otherwise specified.)

Parameter	Symbol	$V_{DD}$	Conditions	Min.	Typ.	Max.	Unit
clocked operation propagation delay time	$t_{PHL}, t_{PLH}$	5V	carry-out line	-	250	500	ns
		10V	$C_L = 50\text{pF}, R_L = 200\text{k}\Omega$	-	100	200	ns
		15V	see Figure 4	-	75	150	ns
		5V	Decode outline	-	350	700	ns
		10V	$C_L = 50\text{pF}, R_L = 200\text{k}\Omega$	-	125	250	ns
		15V	see Figure 4	-	90	180	ns
reset operation propagation delay time	$t_{PHL}, t_{PLH}$	5V	carry-out line	-	275	550	ns
		10V	$C_L = 50\text{pF}, R_L = 200\text{k}\Omega$	-	120	240	ns
		15V	see Figure 4	-	80	160	ns
	$t_{PLH}$	5V	Decode outline	-	300	600	ns
		10V	$C_L = 50\text{pF}, R_L = 200\text{k}\Omega$	-	125	250	ns
		15V	see Figure 4	-	90	180	ns
transition time	$t_{THL}, t_{TLH}$	5V	$C_L = 50\text{pF}, R_L = 200\text{k}\Omega$ see Figure 4	-	100	200	ns
		10V		-	50	100	ns
		15V		-	25	50	ns
Minimum clock pulse width;HIGH	$t_{WCPH}$	5V	-	-	110	220	ns
		10V	-	-	50	100	ns
		15V	-	-	40	80	ns
Minimum MR pulse width;HIGH	$t_{WMRH}$	5V	-	-	100	120	ns
		10V	-	-	50	100	ns
		15V	-	-	25	50	ns
Maximum clock pulse frequency	$f_{max}$	5V	-	5	2.5	-	MHZ
		10V	-	10	5.5	-	MHZ
		15V	-	15	8	-	MHZ





### 3.3.4、AC Characteristics 2

( $T_{amb} = -40^{\circ}\text{C}$  to  $+125^{\circ}\text{C}$ ,  $V_{SS} = 0\text{V}$ , unless otherwise specified.)

Parameter	Symbol	$V_{DD}$	Conditions	Min.	Typ.	Max.	Unit
clocked operation propagation delay time	$t_{PHL}, t_{PLH}$	5V	carry-out line	-	-	600	ns
		10V	$C_L = 50\text{pF}, R_L = 200\text{k}\Omega$	-	-	240	ns
		15V	see Figure 4	-	-	180	ns
		5V	Decode outline	-	-	840	ns
		10V	$C_L = 50\text{pF}, R_L = 200\text{k}\Omega$	-	-	300	ns
		15V	see Figure 4	-	-	216	ns
reset operation propagation delay time	$t_{PHL}, t_{PLH}$	5V	carry-out line	-	-	660	ns
		10V	$C_L = 50\text{pF}, R_L = 200\text{k}\Omega$	-	-	288	ns
		15V	see Figure 4	-	-	192	ns
	$t_{PLH}$	5V	Decode outline	-	-	720	ns
		10V	$C_L = 50\text{pF}, R_L = 200\text{k}\Omega$	-	-	300	ns
		15V	see Figure 4	-	-	216	ns
transition time	$t_{THL}, t_{TLH}$	5V	$C_L = 50\text{pF}, R_L = 200\text{k}\Omega$ see Figure 4	-	-	240	ns
		10V		-	-	120	ns
		15V		-	-	60	ns
Minimum clock pulse width;HIGH	$t_{WCPH}$	5V	-	-	-	264	ns
		10V	-	-	-	120	ns
		15V	-	-	-	96	ns
Minimum MR pulse width;HIGH	$t_{WMRH}$	5V	-	-	-	144	ns
		10V	-	-	-	120	ns
		15V	-	-	-	60	ns
Maximum clock pulse frequency	$f_{max}$	5V	-	4	-	-	MHZ
		10V	-	8	-	-	MHZ
		15V	-	12	-	-	MHZ



## 4、Testing Circuit

### 4.1、AC Testing Circuit

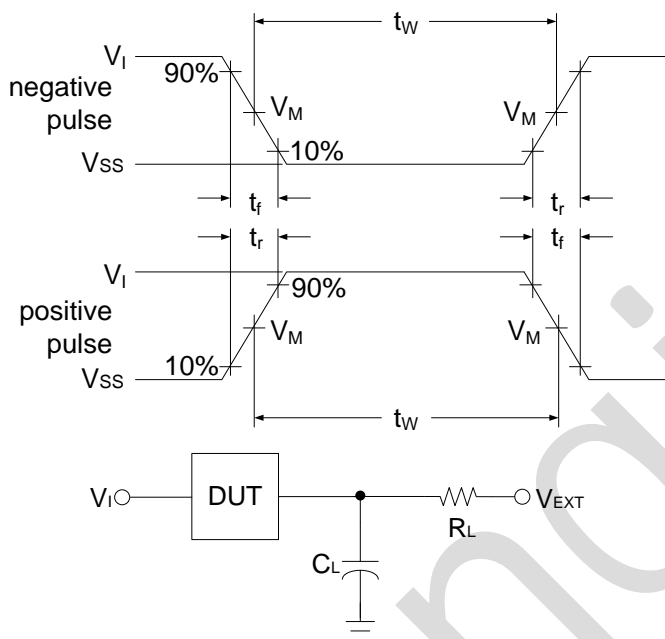

Figure 3. Load circuit

$C_L$  includes probe and jig capacitance.

### 4.2、Test Data

Supply voltage	Input		Load		$V_{EXT}$		
$V_{DD}$	$V_I$	$t_r = t_f$	$C_L$	$R_L$	$t_{PLH}/t_{PHL}$	$t_{PLZ}/t_{PZL}$	$t_{PHZ}/t_{PZH}$
5V to 15V	$V_{DD}$	$\leq 20\text{ns}$	50pF	200k $\Omega$	Open	$V_{DD}$	$V_{SS}$



### 4.3、AC Testing Waveforms

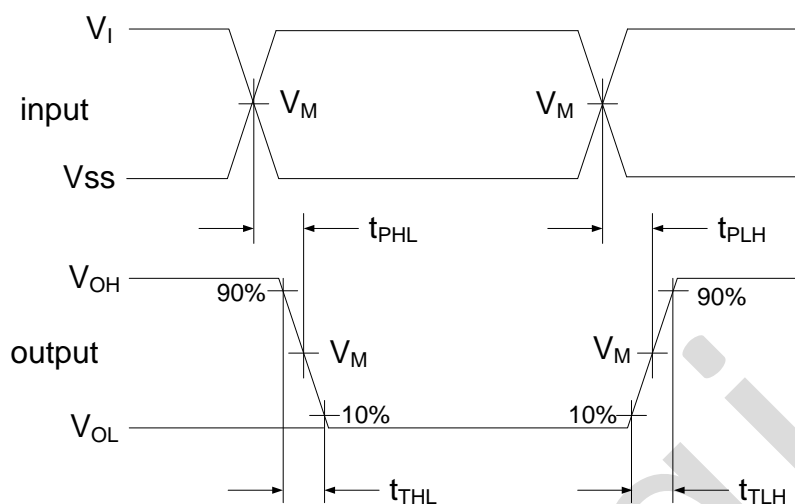

Figure 4. Propagation delay, output transition time

### 4.4、Measurement Points

Supply voltage	Input	Output		
$V_{DD}$	$V_M$	$V_M$	$V_X$	$V_Y$
5V to 15V	$0.5 \times V_{DD}$	$0.5 \times V_{DD}$	$0.1 \times V_{DD}$	$0.9 \times V_{DD}$



## 5、Package Information

### 5.1、DIP16

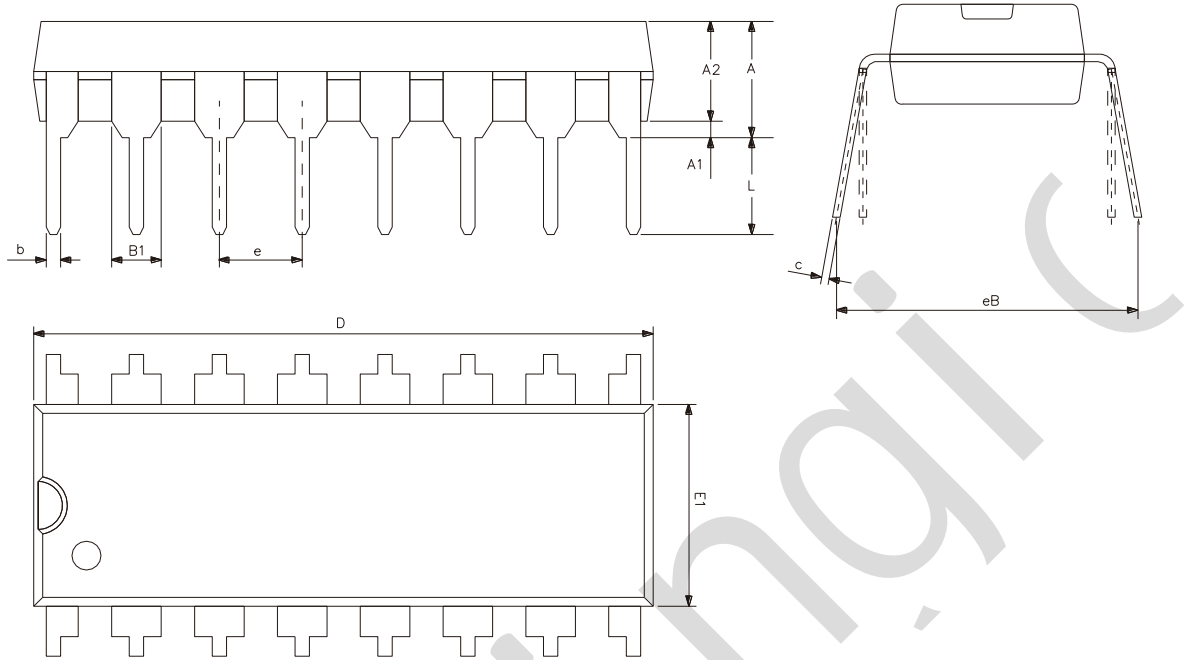

Symbol	Dimensions (mm)	
	Min.	Max.
A2	3.20	3.60
A1	0.51	-
A	3.60	5.33
L	3.00	3.60
b	0.36	0.56
B1	1.52	
D	18.80	19.94
E1	6.20	6.60
e	2.54	
c	0.20	0.36
eB	7.62	9.30



### 5.2、SOP16

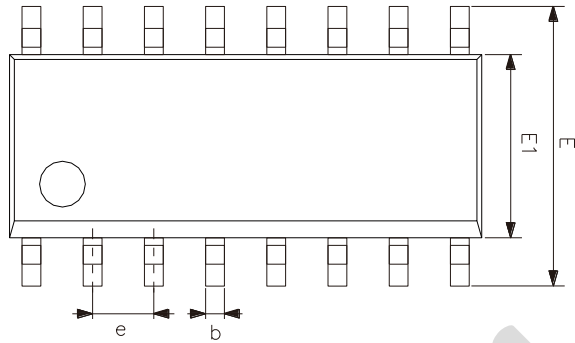
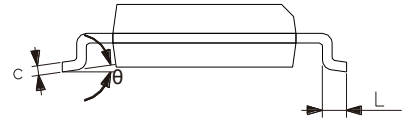
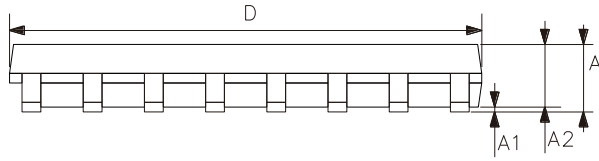

Symbol	Dimensions (mm)	
	Min.	Max.
A	1.35	1.80
A1	0.10	0.25
A2	1.25	1.55
b	0.33	0.51
c	0.19	0.25
D	9.50	10.10
E	5.80	6.30
E1	3.70	4.10
e	1.27	
L	0.35	0.89
$\theta$	0°	8°



### 5.3、TSSOP16

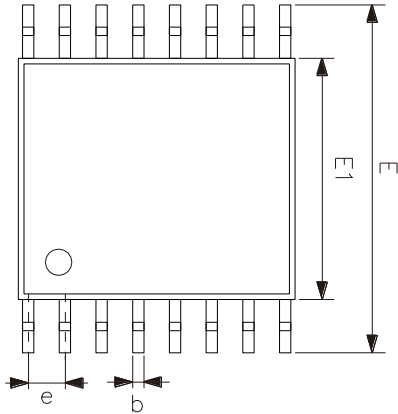
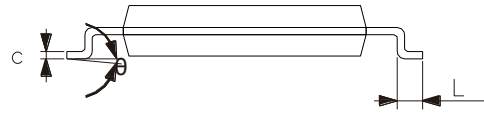
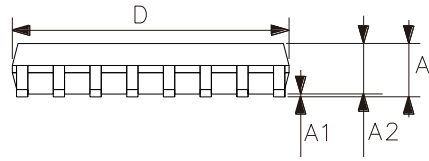

Symbol	Dimensions (mm)	
	Min.	Max.
A	-	1.20
A1	0.05	0.15
A2	0.80	1.05
b	0.19	0.30
c	0.09	0.20
D	4.90	5.10
E1	4.30	4.50
E	6.20	6.60
e	0.65	
L	0.45	0.75
θ	0°	8°



## 6、 Statements And Notes

### 6.1、 The name and content of Hazardous substances or Elements in the product

Part name	Hazardous substances or Elements									
	Lead and lead compounds	Mercury and mercury compounds	Cadmium and cadmium compounds	Hexavalent chromium compounds	Polybrominated biphenyls	Polybrominated biphenyl ethers	Dibutyl phthalate	Butylbenzyl phthalate	Di-2-ethylhexyl phthalate	Diisobutyl phthalate
Lead frame	○	○	○	○	○	○	○	○	○	○
Plastic resin	○	○	○	○	○	○	○	○	○	○
Chip	○	○	○	○	○	○	○	○	○	○
The lead	○	○	○	○	○	○	○	○	○	○
Plastic sheet installed	○	○	○	○	○	○	○	○	○	○
explanation	<p>○: Indicates that the content of hazardous substances or elements in the detection limit of the following the SJ/T11363-2006 standard.</p> <p>×: Indicates that the content of hazardous substances or elements exceeding the SJ/T11363-2006 Standard limit requirements.</p>									

## X-ON Electronics

Largest Supplier of Electrical and Electronic Components

*Click to view similar products for [Counter ICs](#) category:*

*Click to view products by [lingxingic](#) manufacturer:*

Other Similar products are found below :

[CD4018BE](#) [CD4033BE](#) [CD4060BE](#) [CD4040BE](#) [NLV14040BDR2G](#) [RFDIP1607ALM9T21](#) [RFDIP1606L708D1T](#) [RFTIP2510T12A8Q1C](#)  
[74HC161DT](#) [CD4028BM/TR](#) [CD4060DM/TR](#) [CD4022BE](#) [CD4060DMT/TR](#) [CD4060BMT/TR](#) [74HC192M/TR](#) [CD4020BMT/TR](#)  
[74HC193M/TR](#) [CD4518BM/TR](#) [CD4060TA16.TB](#) [CD4060DE](#) [CD4017CN](#) [CD4017SA.TB](#) [CD4022BM/TR](#) [CD4022BMT/TR](#)  
[CD4028BDRG](#) [CD4060BDRG](#) [CD4017DA.TB](#) [CD4520BDRG](#) [CD4520BM\(LX\)](#) [CD4518BM\(LX\)](#) [SN74HC393DR\(LX\)](#) [CD4060BM\(LX\)](#)  
[CD4060BE\(LX\)](#) [SN74HC192N\(XBLW\)](#) [CD4040BM\(LX\)](#) [CD4026BM\(LX\)](#) [CD40103BDR\(LX\)](#) [SN74LS192DR\(LX\)](#) [SN74HC161DR \(LX\)](#)  
[CD40193BE\(LX\)](#) [CD4060BDTR\(XBLW\)](#) [SN74LS393DR](#) [SN74LS193N\(LX\)](#) [SN74LS193DR\(LX\)](#) [CD4017BM\(LX\)](#) [CD40193BM\(LX\)](#)  
[SN74LS192N\(LX\)](#) [SN74LS160N\(LX\)](#) [SN74LS161N\(LX\)](#) [CD4024BM\(LX\)](#)