



灵星芯微 芯片经营

CD4040 (LX) 12-stage Binary Ripple Counter

Product Specification

Specification Revision History:

Version	Date	Description
2023-08-A1	2023-08	New



灵星芯微 芯片经营

Contents

1、 General Description.....	1
2、 Block Diagram And Pin Description	4
2.1、 Block Diagram	4
2.2、 Pin Configurations	4
2.3、 Pin Description.....	5
2.4、 Function Table	5
3、 Electrical Parameter	6
3.1、 Absolute Maximum Ratings.....	6
3.2、 Recommended Operating Conditions	6
3.3、 Electrical Characteristics.....	7
3.3.1、 DC Characteristics 1	7
3.3.2、 DC Characteristics 2	8
3.3.3、 DC Characteristics 3	9
3.3.4、 AC Characteristics 1	10
3.3.5、 AC Characteristics 2	11
3.3.6、 AC Characteristics 3	12
4、 Testing Circuit	13
4.1、 AC Testing Circuit.....	13
4.2、 AC Testing Waveforms.....	14
4.3、 Test Data	14
5、 Package Information	15
5.1、 DIP16.....	15
5.2、 SOP16.....	16
5.3、 TSSOP16.....	17
6、 Statements And Notes	18
6.1、 The name and content of Hazardous substances or Elements in the product	18
6.2、 Notes.....	18



1、General Description

The CD4040 is a 12-stage binary ripple counter with a clock input (\overline{CP}), an overriding asynchronous master reset input (MR) and twelve parallel outputs (Q0 to Q11). Inputs include clamp diodes that enable the use of current limiting resistors to interface inputs to voltages in excess of V_{CC} .

Features:

- Specified from -40°C to $+125^{\circ}\text{C}$
- Packaging information: DIP16/SOP16/TSSOP16



灵星芯微 集成电路

Ordering Information:

Tube packing specifications:

Part number	Packaging form	Marking code	Tube quantity	Boxed tube quantity	Boxed quantity	Notes
CD4040BE(LX)	DIP16	CD4040BE	25 PCS/tube	40 tube/box	1000 PCS/box	Dimensions of plastic enclosure: 19.0mm×6.4mm Pin spacing: 2.54mm
CD4040BM(LX)	SOP16	CD4040BM	50 PCS/tube	200 tube/box	10000 PCS/box	Dimensions of plastic enclosure: 10.0mm×3.9mm Pin spacing: 1.27mm
CD4040BPWR(LX)	TSSOP16	CD4040	96 PCS/tube	200 tube/box	19200 PCS/box	Dimensions of plastic enclosure: 5.0mm×4.4mm Pin spacing: 0.65mm



灵星芯微 集成电路

Reel packing specifications:

Part number	Packaging form	Marking code	Reel quantity	Boxed reel quantity	Notes
CD4040BM(LX)	SOP16	CD4040BM	4000 PCS/reel	8000 PCS/box	Dimensions of plastic enclosure: 10.0mm×3.9mm Pin spacing:1.27mm
CD4040BPWR(LX)	TSSOP16	CD4040	5000 PCS/reel	10000 PCS/box	Dimensions of plastic enclosure: 5.0mm×4.4mm Pin spacing:0.65mm

Note: If the physical information is inconsistent with the ordering information, please refer to the actual product.



2、Block Diagram And Pin Description

2.1、Block Diagram

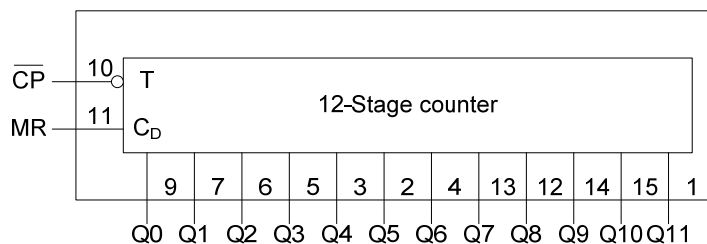

Figure 1. Functional diagram

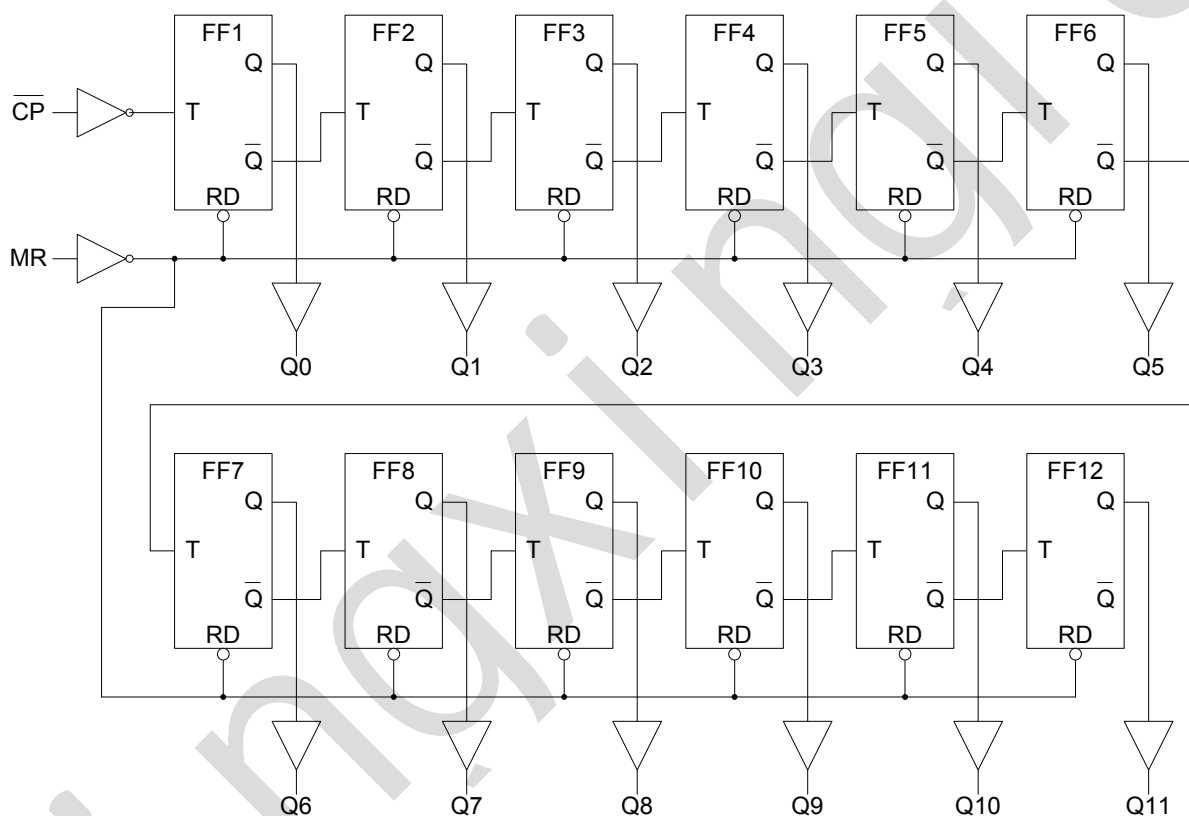
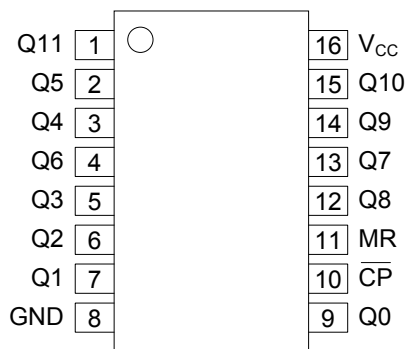

Figure 2. Logic diagram

2.2、Pin Configurations





2.3、Pin Description

Pin No.	Pin Name	Description
1	Q11	output 11
2	Q5	output 5
3	Q4	output 4
4	Q6	output 6
5	Q3	output 3
6	Q2	output 2
7	Q1	output 1
8	GND	ground (0V)
9	Q0	output 0
10	$\overline{\text{CP}}$	clock input (HIGH-to-LOW, edge-triggered)
11	MR	master reset input (active HIGH)
12	Q8	output 8
13	Q7	output 7
14	Q9	Output 9
15	Q10	output 10
16	V _{CC}	positive supply voltage

2.4、Function Table

Input		Output
$\overline{\text{CP}}$	MR	Q0 to Q11
↑	L	no change
↓	L	count
X	H	L

Note:

H=HIGH voltage level;

L=LOW voltage level;

X=don't care;

↑=LOW-to-HIGH clock transition;

↓=HIGH-to-LOW clock transition.



3、Electrical Parameter

3.1、Absolute Maximum Ratings

($T_{amb}=25^{\circ}\text{C}$, voltages are referenced to GND (ground=0V), unless otherwise specified)

Characteristic	Symbol	Conditions	Min.	Max.	Unit
supply voltage	V_{CC}	-	-0.5	+7.0	V
input clamping current	I_{IK}	$V_I < -0.5\text{V}$ or $V_I > V_{CC} + 0.5\text{V}$	-	± 20	mA
output clamping current	I_{OK}	$V_I < -0.5\text{V}$ or $V_I > V_{CC} + 0.5\text{V}$	-	± 20	mA
output current	I_O	$0.5\text{V} < V_O < V_{CC} + 0.5\text{V}$	-	± 25	mA
supply current	I_{CC}	-	-	± 50	mA
ground current	I_{GND}	-	-	± 50	mA
storage temperature	T_{stg}	-	-65	+150	$^{\circ}\text{C}$
soldering temperature	T_L	10s	DIP	245	$^{\circ}\text{C}$
			SOP/TSSOP	260	$^{\circ}\text{C}$

3.2、Recommended Operating Conditions

Parameter	Symbol	Conditions	Min.	Typ.	Max.	Unit
supply voltage	V_{CC}	-	2.0	5.0	6.0	V
input voltage	V_I	-	0	-	V_{CC}	V
output voltage	V_O	-	0	-	V_{CC}	V
ambient temperature	T_{amb}	-	-40	-	+125	$^{\circ}\text{C}$



3.3、Electrical Characteristics

3.3.1、DC Characteristics 1

($T_{amb}=25^{\circ}C$, voltages are referenced to GND (ground=0V), unless otherwise specified)

Parameter	Symbol	Conditions	Min.	Typ.	Max.	Unit	
HIGH-level input voltage	V_{IH}	$V_{CC}=2.0V$	1.5	1.2	-	V	
		$V_{CC}=4.5V$	3.15	2.4	-	V	
		$V_{CC}=6.0V$	4.2	3.2	-	V	
LOW-level input voltage	V_{IL}	$V_{CC}=2.0V$	-	0.8	0.5	V	
		$V_{CC}=4.5V$	-	2.1	1.35	V	
		$V_{CC}=6.0V$	-	2.8	1.8	V	
HIGH-level output voltage	V_{OH}	$V_I=V_{IH}$ or V_{IL}	$I_O=-20\mu A; V_{CC}=2.0V$	1.9	2.0	-	V
			$I_O=-20\mu A; V_{CC}=4.5V$	4.4	4.5	-	V
			$I_O=-20\mu A; V_{CC}=6.0V$	5.9	6.0	-	V
			$I_O=-4.0mA; V_{CC}=4.5V$	3.98	4.32	-	V
			$I_O=-5.2mA; V_{CC}=6.0V$	5.48	5.81	-	V
LOW-level output voltage	V_{OL}	$V_I=V_{IH}$ or V_{IL}	$I_O=20\mu A; V_{CC}=2.0V$	-	0	0.1	V
			$I_O=20\mu A; V_{CC}=4.5V$	-	0	0.1	V
			$I_O=20\mu A; V_{CC}=6.0V$	-	0	0.1	V
			$I_O=4.0mA; V_{CC}=4.5V$	-	0.15	0.26	V
			$I_O=5.2mA; V_{CC}=6.0V$	-	0.16	0.26	V
input leakage current	I_I	$V_I=V_{CC}$ or GND; $V_{CC}=6.0V$	-	-	± 1	μA	
supply current	I_{CC}	$V_I=V_{CC}$ or GND; $I_O=0A; V_{CC}=6.0V$	-	-	8	μA	



3.3.2、DC Characteristics 2

($T_{amb} = -40^{\circ}\text{C}$ to $+85^{\circ}\text{C}$, voltages are referenced to GND (ground=0V), unless otherwise specified)

Parameter	Symbol	Conditions	Min.	Typ.	Max.	Unit	
HIGH-level input voltage	V_{IH}	$V_{CC}=2.0\text{V}$	1.5	-	-	V	
		$V_{CC}=4.5\text{V}$	3.15	-	-	V	
		$V_{CC}=6.0\text{V}$	4.2	-	-	V	
LOW-level input voltage	V_{IL}	$V_{CC}=2.0\text{V}$	-	-	0.5	V	
		$V_{CC}=4.5\text{V}$	-	-	1.35	V	
		$V_{CC}=6.0\text{V}$	-	-	1.8	V	
HIGH-level output voltage	V_{OH}	$V_I = V_{IH}$ or V_{IL}	$I_O = -20\mu\text{A}; V_{CC} = 2.0\text{V}$	1.9	-	-	V
			$I_O = -20\mu\text{A}; V_{CC} = 4.5\text{V}$	4.4	-	-	V
			$I_O = -20\mu\text{A}; V_{CC} = 6.0\text{V}$	5.9	-	-	V
			$I_O = -4.0\text{mA}; V_{CC} = 4.5\text{V}$	3.84	-	-	V
			$I_O = -5.2\text{mA}; V_{CC} = 6.0\text{V}$	5.34	-	-	V
LOW-level output voltage	V_{OL}	$V_I = V_{IH}$ or V_{IL}	$I_O = 20\mu\text{A}; V_{CC} = 2.0\text{V}$	-	-	0.1	V
			$I_O = 20\mu\text{A}; V_{CC} = 4.5\text{V}$	-	-	0.1	V
			$I_O = 20\mu\text{A}; V_{CC} = 6.0\text{V}$	-	-	0.1	V
			$I_O = 4.0\text{mA}; V_{CC} = 4.5\text{V}$	-	-	0.33	V
			$I_O = 5.2\text{mA}; V_{CC} = 6.0\text{V}$	-	-	0.33	V
input leakage current	I_I	$V_I = V_{CC}$ or GND; $V_{CC} = 6.0\text{V}$	-	-	± 1.0	μA	
supply current	I_{CC}	$V_I = V_{CC}$ or GND; $I_O = 0\text{A}; V_{CC} = 6.0\text{V}$	-	-	80	μA	



3.3.3、DC Characteristics 3

($T_{amb} = -40^{\circ}\text{C}$ to $+125^{\circ}\text{C}$, voltages are referenced to GND (ground=0V), unless otherwise specified)

Parameter	Symbol	Conditions	Min.	Typ.	Max.	Unit	
HIGH-level input voltage	V_{IH}	$V_{CC}=2.0\text{V}$	1.5	-	-	V	
		$V_{CC}=4.5\text{V}$	3.15	-	-	V	
		$V_{CC}=6.0\text{V}$	4.2	-	-	V	
LOW-level input voltage	V_{IL}	$V_{CC}=2.0\text{V}$	-	-	0.5	V	
		$V_{CC}=4.5\text{V}$	-	-	1.35	V	
		$V_{CC}=6.0\text{V}$	-	-	1.8	V	
HIGH-level output voltage	V_{OH}	$V_I = V_{IH}$ or V_{IL}	$I_O = -20\mu\text{A}; V_{CC} = 2.0\text{V}$	1.9	-	-	V
			$I_O = -20\mu\text{A}; V_{CC} = 4.5\text{V}$	4.4	-	-	V
			$I_O = -20\mu\text{A}; V_{CC} = 6.0\text{V}$	5.9	-	-	V
			$I_O = -4.0\text{mA}; V_{CC} = 4.5\text{V}$	3.7	-	-	V
			$I_O = -5.2\text{mA}; V_{CC} = 6.0\text{V}$	5.2	-	-	V
LOW-level output voltage	V_{OL}	$V_I = V_{IH}$ or V_{IL}	$I_O = 20\mu\text{A}; V_{CC} = 2.0\text{V}$	-	-	0.1	V
			$I_O = 20\mu\text{A}; V_{CC} = 4.5\text{V}$	-	-	0.1	V
			$I_O = 20\mu\text{A}; V_{CC} = 6.0\text{V}$	-	-	0.1	V
			$I_O = 4.0\text{mA}; V_{CC} = 4.5\text{V}$	-	-	0.4	V
			$I_O = 5.2\text{mA}; V_{CC} = 6.0\text{V}$	-	-	0.4	V
input leakage current	I_I	$V_I = V_{CC}$ or GND; $V_{CC} = 6.0\text{V}$	-	-	± 1.0	μA	
supply current	I_{CC}	$V_I = V_{CC}$ or GND; $I_O = 0\text{A}; V_{CC} = 6.0\text{V}$	-	-	160	μA	



3.3.4、AC Characteristics 1

($T_{amb}=25^{\circ}\text{C}$, $GND=0\text{V}$, $C_L=50\text{pF}$, unless otherwise specified)

Parameter	Symbol	Conditions	Min.	Typ.	Max.	Unit	
propagation delay	t_{pd}	$\overline{\text{CP}}$ to Q0; see Figure 4 ^[1]	$V_{CC}=2.0\text{V}$	-	47	150	ns
			$V_{CC}=4.5\text{V}$	-	17	30	ns
			$V_{CC}=5.0\text{V}; C_L=15\text{pF}$	-	14	-	ns
			$V_{CC}=6.0\text{V}$	-	14	26	ns
		Qn to Qn+1; see Figure 4	$V_{CC}=2.0\text{V}$	-	28	100	ns
			$V_{CC}=4.5\text{V}$	-	10	20	ns
			$V_{CC}=5.0\text{V}; C_L=15\text{pF}$	-	8	-	ns
			$V_{CC}=6.0\text{V}$	-	8	17	ns
HIGH to LOW Propagation delay	t_{PHL}	MR to Qn; see Figure 4	$V_{CC}=2.0\text{V}$	-	61	185	ns
			$V_{CC}=4.5\text{V}$	-	22	37	ns
			$V_{CC}=6.0\text{V}$	-	18	31	ns
transition time	t_t	Qn; see Figure 4 ^[2]	$V_{CC}=2.0\text{V}$	-	19	75	ns
			$V_{CC}=4.5\text{V}$	-	7	15	ns
			$V_{CC}=6.0\text{V}$	-	6	13	ns
pulse width	t_w	$\overline{\text{CP}}$ input, HIGH or LOW; see Figure 4	$V_{CC}=2.0\text{V}$	80	14	-	ns
			$V_{CC}=4.5\text{V}$	16	5	-	ns
			$V_{CC}=6.0\text{V}$	14	4	-	ns
		MR input, HIGH; see Figure 4	$V_{CC}=2.0\text{V}$	80	22	-	ns
			$V_{CC}=4.5\text{V}$	16	8	-	ns
			$V_{CC}=6.0\text{V}$	14	6	-	ns
recovery time	t_{rec}	MR to $\overline{\text{CP}}$; see Figure 4	$V_{CC}=2.0\text{V}$	50	8	-	ns
			$V_{CC}=4.5\text{V}$	10	3	-	ns
			$V_{CC}=6.0\text{V}$	9	2	-	ns
maximum frequency	f_{max}	$\overline{\text{CP}}$ input; see Figure 4	$V_{CC}=2.0\text{V}$	6	27	-	MHz
			$V_{CC}=4.5\text{V}$	30	82	-	MHz
			$V_{CC}=5.0\text{V}; C_L=15\text{pF}$	-	90	-	MHz
			$V_{CC}=6.0\text{V}$	35	98	-	MHz

Note:

[1] t_{pd} is the same as t_{PHL} , t_{PLH} .

[2] t_t is the same as t_{THL} , t_{TLH} .



3.3.5、AC Characteristics 2

($T_{amb} = -40^{\circ}\text{C}$ to $+85^{\circ}\text{C}$, $GND = 0\text{V}$, $C_L = 50\text{pF}$, unless otherwise specified)

Parameter	Symbol	Conditions	Min.	Typ.	Max.	Unit	
propagation delay	t_{pd}	\overline{CP} to Q0; see Figure 4 ^[1]	$V_{CC} = 2.0\text{V}$	-	-	190	ns
			$V_{CC} = 4.5\text{V}$	-	-	38	ns
			$V_{CC} = 6.0\text{V}$	-	-	33	ns
		Qn to Qn+1; see Figure 4	$V_{CC} = 2.0\text{V}$	-	-	125	ns
			$V_{CC} = 4.5\text{V}$	-	-	25	ns
			$V_{CC} = 6.0\text{V}$	-	-	21	ns
HIGH to LOW Propagation delay	t_{PHL}	MR to Qn; see Figure 4	$V_{CC} = 2.0\text{V}$	-	-	230	ns
			$V_{CC} = 4.5\text{V}$	-	-	46	ns
			$V_{CC} = 6.0\text{V}$	-	-	39	ns
transition time	t_t	Qn; see Figure 4 ^[2]	$V_{CC} = 2.0\text{V}$	-	-	95	ns
			$V_{CC} = 4.5\text{V}$	-	-	19	ns
			$V_{CC} = 6.0\text{V}$	-	-	16	ns
pulse width	t_w	\overline{CP} input, HIGH or LOW; see Figure 4	$V_{CC} = 2.0\text{V}$	100	-	-	ns
			$V_{CC} = 4.5\text{V}$	20	-	-	ns
			$V_{CC} = 6.0\text{V}$	17	-	-	ns
		MR input, HIGH; see Figure 4	$V_{CC} = 2.0\text{V}$	100	-	-	ns
			$V_{CC} = 4.5\text{V}$	20	-	-	ns
			$V_{CC} = 6.0\text{V}$	17	-	-	ns
recovery time	t_{rec}	MR to \overline{CP} ; see Figure 4	$V_{CC} = 2.0\text{V}$	65	-	-	ns
			$V_{CC} = 4.5\text{V}$	13	-	-	ns
			$V_{CC} = 6.0\text{V}$	11	-	-	ns
maximum frequency	f_{max}	\overline{CP} input; see Figure 4	$V_{CC} = 2.0\text{V}$	4.8	-	-	MHz
			$V_{CC} = 4.5\text{V}$	24	-	-	MHz
			$V_{CC} = 6.0\text{V}$	28	-	-	MHz

Note:

[1] t_{pd} is the same as t_{PHL} , t_{PLH} .

[2] t_t is the same as t_{THL} , t_{TLH} .



3.3.6、AC Characteristics 3

($T_{amb} = -40^{\circ}\text{C}$ to $+125^{\circ}\text{C}$, $GND = 0\text{V}$, $C_L = 50\text{pF}$, unless otherwise specified)

Parameter	Symbol	Conditions	Min.	Typ.	Max.	Unit	
propagation delay	t_{pd}	$\overline{\text{CP}}$ to Q0; see Figure 4 ^[1]	$V_{CC} = 2.0\text{V}$	-	-	225	ns
			$V_{CC} = 4.5\text{V}$	-	-	45	ns
			$V_{CC} = 6.0\text{V}$	-	-	38	ns
		Qn to Qn+1; see Figure 4	$V_{CC} = 2.0\text{V}$	-	-	150	ns
			$V_{CC} = 4.5\text{V}$	-	-	30	ns
			$V_{CC} = 6.0\text{V}$	-	-	26	ns
HIGH to LOW Propagation delay	t_{PHL}	MR to Qn; see Figure 4	$V_{CC} = 2.0\text{V}$	-	-	280	ns
			$V_{CC} = 4.5\text{V}$	-	-	56	ns
			$V_{CC} = 6.0\text{V}$	-	-	48	ns
transition time	t_t	Qn; see Figure 4 ^[2]	$V_{CC} = 2.0\text{V}$	-	-	110	ns
			$V_{CC} = 4.5\text{V}$	-	-	22	ns
			$V_{CC} = 6.0\text{V}$	-	-	19	ns
pulse width	t_w	$\overline{\text{CP}}$ input, HIGH or LOW; see Figure 4	$V_{CC} = 2.0\text{V}$	120	-	-	ns
			$V_{CC} = 4.5\text{V}$	24	-	-	ns
			$V_{CC} = 6.0\text{V}$	20	-	-	ns
		MR input, HIGH; see Figure 4	$V_{CC} = 2.0\text{V}$	120	-	-	ns
			$V_{CC} = 4.5\text{V}$	24	-	-	ns
			$V_{CC} = 6.0\text{V}$	20	-	-	ns
recovery time	t_{rec}	MR to $\overline{\text{CP}}$; see Figure 4	$V_{CC} = 2.0\text{V}$	75	-	-	ns
			$V_{CC} = 4.5\text{V}$	15	-	-	ns
			$V_{CC} = 6.0\text{V}$	13	-	-	ns
maximum frequency	f_{max}	$\overline{\text{CP}}$ input; see Figure 4	$V_{CC} = 2.0\text{V}$	4	-	-	MHz
			$V_{CC} = 4.5\text{V}$	20	-	-	MHz
			$V_{CC} = 6.0\text{V}$	24	-	-	MHz

Note:

[1] t_{pd} is the same as t_{PHL} , t_{PLH} .

[2] t_t is the same as t_{THL} , t_{TLH} .

4、Testing Circuit

4.1、AC Testing Circuit

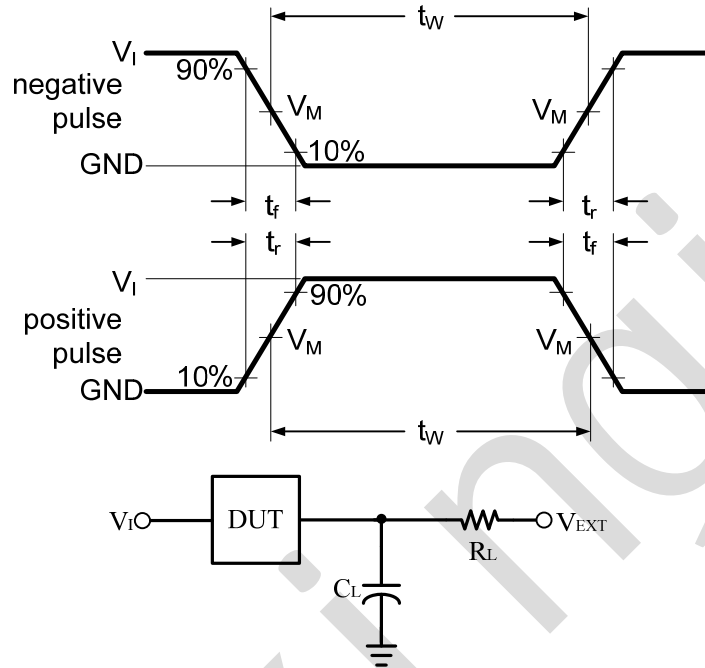

Figure 3. Test circuit for measuring switching times

C_L includes probe and jig capacitance.



4.2、AC Testing Waveforms

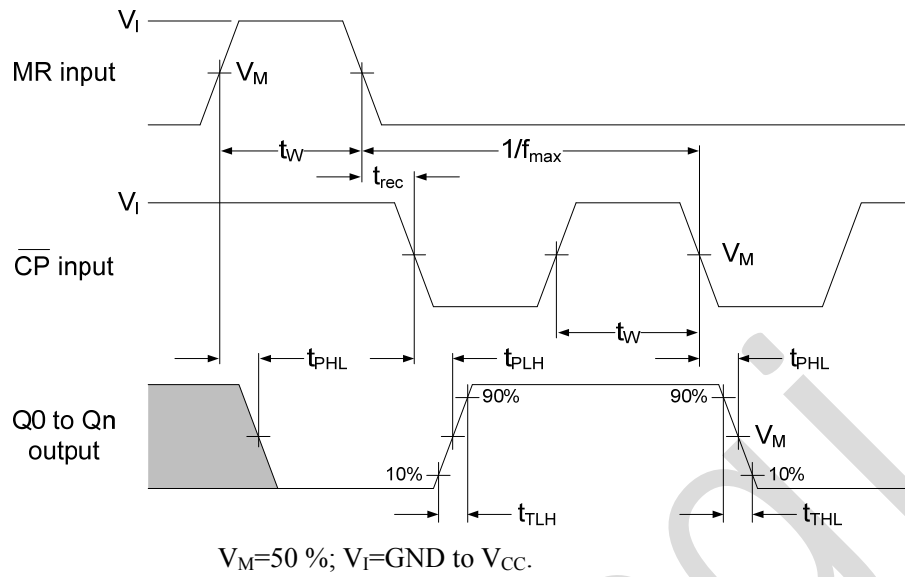

Figure 4. Clock propagation delays, pulse width, transition times, maximum pulse frequency and master resets

4.3、Test Data

Input		Load	Test
V_I	t_r, t_f	C_L	
V_{CC}	6ns	15pF, 50pF	t_{PHL}, t_{PLH}



5、Package Information

5.1、DIP16

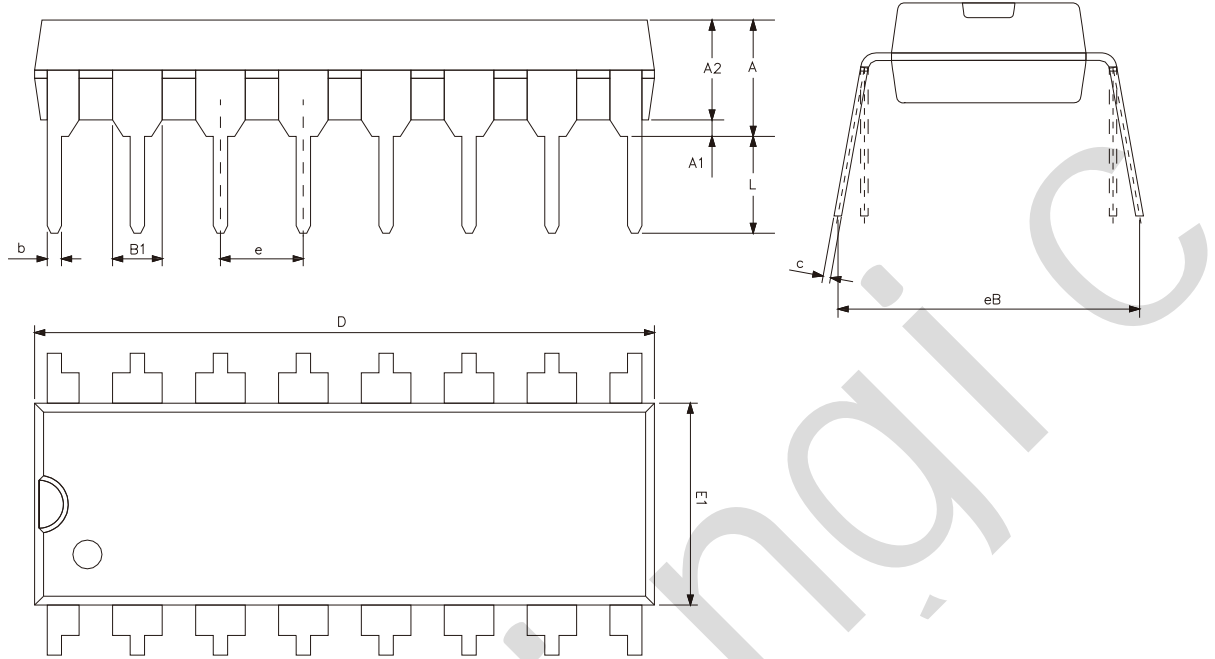

Symbol	Dimensions (mm)	
	Min.	Max.
A2	3.20	3.60
A1	0.51	-
A	3.60	5.33
L	3.00	3.60
b	0.36	0.56
B1	1.52	
D	18.80	19.94
E1	6.20	6.60
e	2.54	
c	0.20	0.36
eB	7.62	9.30



5.2、SOP16

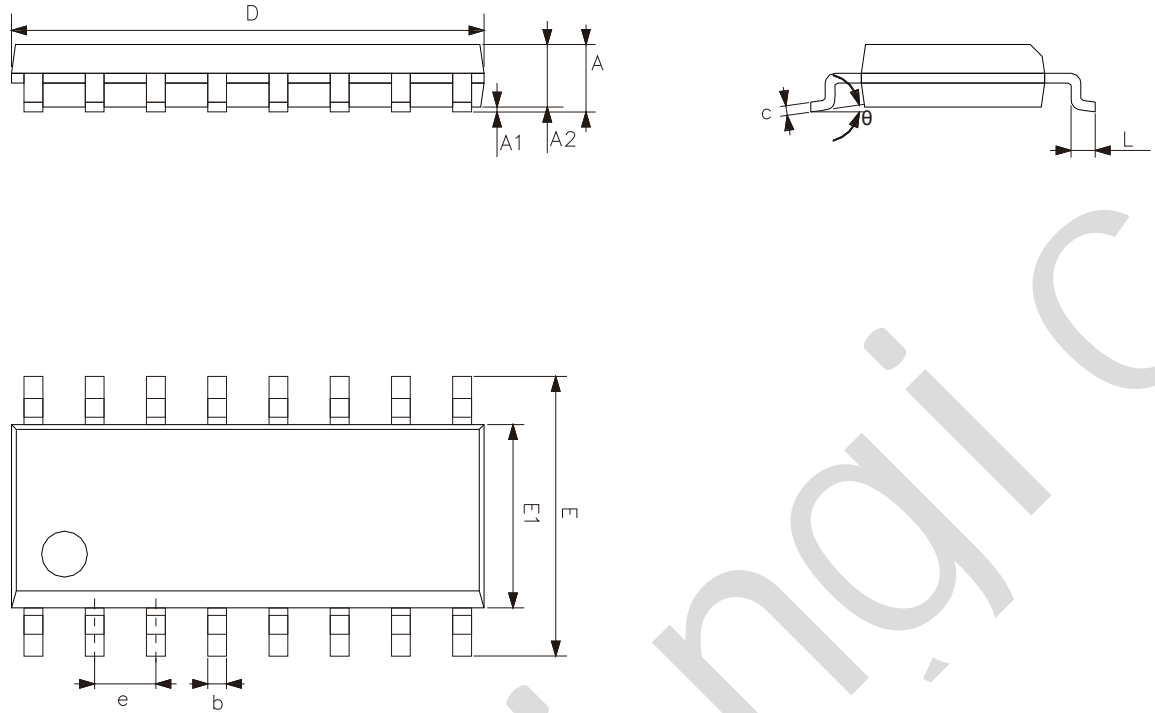

Symbol	Dimensions (mm)	
	Min.	Max.
A	1.35	1.80
A1	0.10	0.25
A2	1.25	1.55
b	0.33	0.51
c	0.19	0.25
D	9.50	10.10
E	5.80	6.30
E1	3.70	4.10
e	1.27	
L	0.35	0.89
θ	0°	8°



5.3、TSSOP16

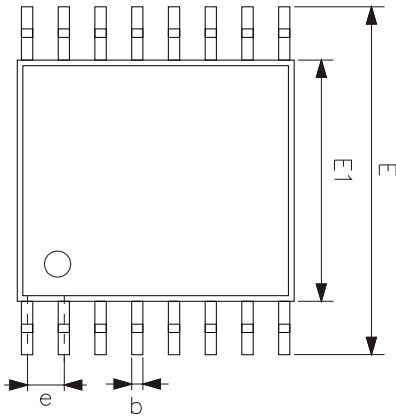
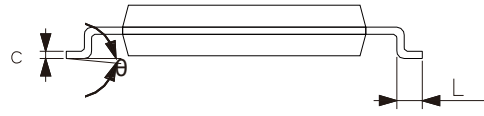
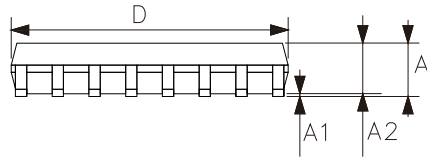

Symbol	Dimensions (mm)	
	Min.	Max.
A	-	1.20
A1	0.05	0.15
A2	0.80	1.05
b	0.19	0.30
c	0.09	0.20
D	4.90	5.10
E1	4.30	4.50
E	6.20	6.60
e	0.65	
L	0.45	0.75
θ	0°	8°



6、 Statements And Notes

6.1、 The name and content of Hazardous substances or Elements in the product

Part name	Hazardous substances or Elements									
	Lead and lead compounds	Mercury and mercury compounds	Cadmium and cadmium compounds	Hexavalent chromium compounds	Polybrominated biphenyls	Polybrominated biphenyl ethers	Dibutyl phthalate	Butylbenzyl phthalate	Di-2-ethylhexyl phthalate	Diisobutyl phthalate
Lead frame	○	○	○	○	○	○	○	○	○	○
Plastic resin	○	○	○	○	○	○	○	○	○	○
Chip	○	○	○	○	○	○	○	○	○	○
The lead	○	○	○	○	○	○	○	○	○	○
Plastic sheet installed	○	○	○	○	○	○	○	○	○	○
explanation	○: Indicates that the content of hazardous substances or elements in the detection limit of the following the SJ/T11363-2006 standard. ×: Indicates that the content of hazardous substances or elements exceeding the SJ/T11363-2006 Standard limit requirements.									

6.2、 Notes

We recommend you to read this chapter carefully before using this product.

The information in this chapter is provided for reference only and Lingxing disclaims any express or implied warranties, including but not limited to applicability, special application or non-infringement of third party rights.

This product is not suitable for critical equipment such as life-saving, life-sustaining or safety equipment. It is also not suitable for applications that may result in personal injury, death, or serious property or environmental damage due to product malfunction or failure. Lingxing will not be liable for any damages incurred by the customers at their own risk for such applications.

The customer is responsible for conducting all necessary tests Lingxing's application to avoid failure in the application or the application of the customer's third party users. Lingxing does not accept any liability.

The Company reserves the right to change or improve the information published in this chapter at any time. The information in this chapter are subject to change without notice. We recommend the customer to consult our sales staff before purchasing.

Please obtain related materials form Lingxing's regular channels and we are not responsible for its content if it is provided by sources other than our company.

In case of any conflict between the Chinese and English version, the version is subject to the Chinese one.

X-ON Electronics

Largest Supplier of Electrical and Electronic Components

Click to view similar products for [Counter ICs](#) category:

Click to view products by [lingxingic](#) manufacturer:

Other Similar products are found below :

[CD4018BE](#) [CD4033BE](#) [CD4060BE](#) [CD4040BE](#) [NLV14040BDR2G](#) [RFDIP1607ALM9T21](#) [RFDIP1606L708D1T](#) [RFTIP2510T12A8Q1C](#)
[74HC161DT](#) [CD4028BM/TR](#) [CD4060DM/TR](#) [CD4022BE](#) [CD4060DMT/TR](#) [CD4060BMT/TR](#) [74HC192M/TR](#) [CD4020BMT/TR](#)
[74HC193M/TR](#) [CD4518BM/TR](#) [CD4060TA16.TB](#) [CD4060DE](#) [CD4017CN](#) [CD4017SA.TB](#) [CD4022BM/TR](#) [CD4022BMT/TR](#)
[CD4028BDRG](#) [CD4060BDRG](#) [CD4017DA.TB](#) [CD4520BDRG](#) [CD4520BM\(LX\)](#) [CD4518BM\(LX\)](#) [SN74HC393DR\(LX\)](#) [CD4060BM\(LX\)](#)
[CD4060BE\(LX\)](#) [SN74HC192N\(XBLW\)](#) [CD4040BM\(LX\)](#) [CD4026BM\(LX\)](#) [CD40103BDR\(LX\)](#) [SN74LS192DR\(LX\)](#) [SN74HC161DR \(LX\)](#)
[CD40193BE\(LX\)](#) [CD4060BDTR\(XBLW\)](#) [SN74LS393DR](#) [SN74LS193N\(LX\)](#) [SN74LS193DR\(LX\)](#) [CD4017BM\(LX\)](#) [CD40193BM\(LX\)](#)
[SN74LS192N\(LX\)](#) [SN74LS160N\(LX\)](#) [SN74LS161N\(LX\)](#) [CD4024BM\(LX\)](#)