



# CD4051 (LX)

## 8-channel Analog Multiplexer/Demultiplexer

### Product Specification

#### Specification Revision History:

Version	Date	Description
2019-06-A1	2019-06	New
2021-12-A2	2021-12	Modify Ordering Information
2023-04-B1	2023-04	Update the template



# Contents

<b>1、 General Description.....</b>	<b>3</b>
<b>2、 Block Diagram And Pin Description .....</b>	<b>5</b>
2.1、 Block Diagram .....	5
2.2、 Pin Configurations.....	6
2.3、 Pin Description .....	7
2.4、 Function Table.....	7
<b>3、 Electrical Parameter .....</b>	<b>8</b>
3.1、 Absolute Maximum Ratings.....	8
3.2、 Recommended Operating Conditions .....	8
3.3、 Electrical Characteristics .....	9
3.3.1、 DC Characteristics 1 .....	9
3.3.2、 DC Characteristics 2 .....	9
3.3.3、 DC Characteristics 3 .....	10
3.3.4、 AC Characteristics 1 .....	10
3.3.5、 AC Characteristics 2 .....	11
<b>4、 Testing Circuit .....</b>	<b>11</b>
4.1、 AC Testing Circuit 1 .....	11
4.2、 AC Testing Waveforms.....	12
4.3、 AC Testing Circuit 2 .....	12
4.4、 Measurement Points .....	13
4.5、 Test Data .....	13
<b>5、 Package Information .....</b>	<b>14</b>
5.1、 DIP16 .....	14
5.2、 SOP16 .....	15
5.3、 TSSOP16.....	16
<b>6、 Statements And Notes .....</b>	<b>17</b>
6.1、 The name and content of Hazardous substances or Elements in the product .....	17
6.2、 Notes .....	17



## 1、 General Description

The CD4051 is an 8-channel analog multiplexer/demultiplexer with three address inputs (S1 to S3), an active LOW enable input ( $\bar{E}$ ), eight independent inputs/outputs (Y0 to Y7) and a common input/output (Z). The device contains eight bidirectional analog switches, each with one side connected to an independent input/output (Y0 to Y7) and the other side connected to a common input/output (Z). With  $\bar{E}$  LOW, one of the eight switches is selected (low-impedance ON-state) by S1 to S3. With  $\bar{E}$  HIGH, all switches are in the high-impedance OFF-state, independent of S1 to S3. If break before make is needed, then it is necessary to use the enable input.

$V_{DD}$  and  $V_{SS}$  are the supply voltage connections for the digital control inputs (S1 to S3, and  $\bar{E}$ ). The  $V_{DD}$  to  $V_{SS}$  range is 3V to 9V. The analog inputs/outputs (Y0 to Y7, and Z) can swing between  $V_{DD}$  as a positive limit and  $V_{EE}$  as a negative limit.  $V_{DD}-V_{EE}$  may not exceed 9V. Unused inputs must be connected to  $V_{DD}$ ,  $V_{SS}$ , or another input. For operation as a digital multiplexer/demultiplexer,  $V_{EE}$  is connected to  $V_{SS}$  (typically ground).  $V_{EE}$  and  $V_{SS}$  are the supply voltage connections for the switches.

### Features:

- Wide supply voltage range from 3V to 9V
- Fully static operation
- 5V and 9V parametric ratings
- Standardized symmetrical output characteristics
- Specified from -40°C to +125°C
- Packaging information: DIP16/SOP16/TSSOP16



**Ordering Information:**

**Tube packing specifications:**

Part number	Packaging form	Marking code	Tube quantity	Boxed tube quantity	Boxed quantity	Notes
CD4051BE (LX)	DIP16	CD4051BE	25 PCS/tube	40 tube/box	1000 PCS/box	Dimensions of plastic enclosure: 19.0mm×6.4mm Pin spacing: 2.54mm
CD4051BM (LX)	SOP16	CD4051BM	50 PCS/tube	200 tube/box	10000 PCS/box	Dimensions of plastic enclosure: 10.0mm×3.9mm Pin spacing: 1.27mm
CD4051PW (LX)	TSSOP16	CD4051	96 PCS/tube	200 tube/box	19200 PCS/box	Dimensions of plastic enclosure: 5.0mm×4.4mm Pin spacing: 0.65mm

**Reel packing specifications:**

Part number	Packaging form	Marking code	Reel quantity	Boxed reel quantity	Notes
CD4051BM (LX)	SOP16	CD4051BM	2500 PCS/reel	5000 PCS/box	Dimensions of plastic enclosure: 10.0mm×3.9mm Pin spacing:1.27mm
CD4051PW (LX)	TSSOP16	CD4051	5000 PCS/reel	10000 PCS/box	Dimensions of plastic enclosure: 5.0mm×4.4mm Pin spacing:0.65mm

Note: If the physical information is inconsistent with the ordering information, please refer to the actual product.



## 2、Block Diagram And Pin Description

### 2.1、Block Diagram

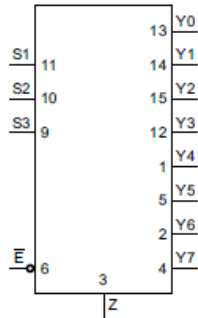

Figure 1. Logic symbol

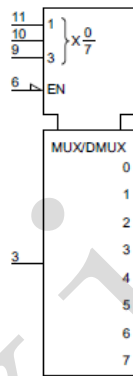

Figure 2. IEC logic symbol

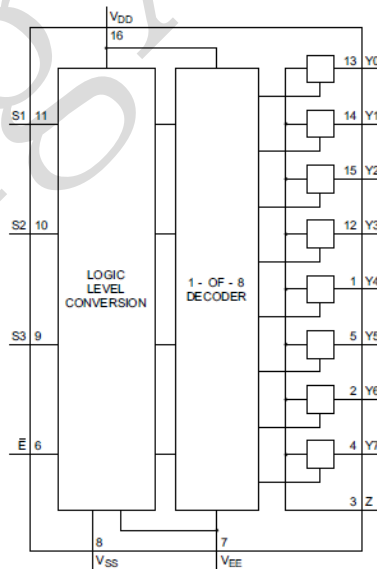

Figure 3. Functional diagram

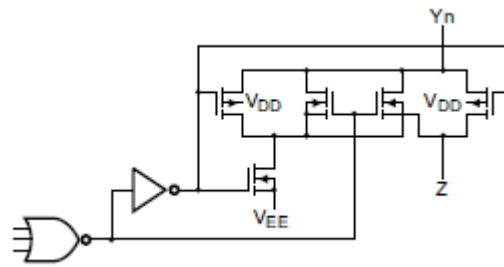

Figure 4. Schematic diagram (one switch)

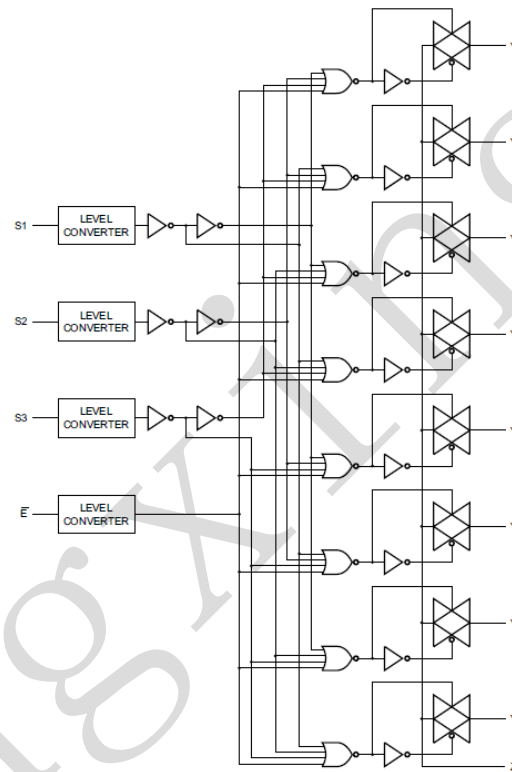
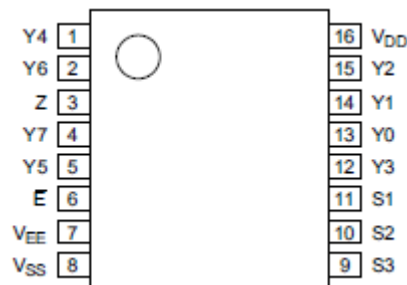

Figure 5. Logic diagram

## 2.2. Pin Configurations





### 2.3、Pin Description

Pin No.	Pin Name	Description
1	Y4	independent input or output
2	Y6	independent input or output
3	Z	common output or input
4	Y7	independent input or output
5	Y5	independent input or output
6	$\bar{E}$	enable input (active LOW)
7	V <sub>EE</sub>	supply voltage
8	V <sub>SS</sub>	ground (0V)
9	S3	select input
10	S2	select input
11	S1	select input
12	Y3	independent input or output
13	Y0	independent input or output
14	Y1	independent input or output
15	Y2	independent input or output
16	V <sub>DD</sub>	supply voltage

### 2.4、Function Table

Input				Channel ON
$\bar{E}$	S3	S2	S1	
L	L	L	L	Y0 to Z
L	L	L	H	Y1 to Z
L	L	H	L	Y2 to Z
L	L	H	H	Y3 to Z
L	H	L	L	Y4 to Z
L	H	L	H	Y5 to Z
L	H	H	L	Y6 to Z
L	H	H	H	Y7 to Z
H	X	X	X	switches off

Note: H=HIGH voltage level; L=LOW voltage level; X=don't care.



### 3、Electrical Parameter

#### 3.1、Absolute Maximum Ratings

(Voltages are referenced to  $V_{SS}$  (ground=0V), unless otherwise specified.)

Parameter	Symbol	Conditions	Min.	Max.	Unit
supply voltage	$V_{DD}$	-	-0.5	+12	V
Power Supply Voltage	$V_{EE}$	-	-12	+0.5	V
input clamping current	$I_{IK}$	$V_I < 0.5V$ or $V_I > V_{DD} + 0.5V$	-	$\pm 10$	mA
switch current	$I$	-	-	$\pm 10$	mA
input voltage	$V_I$	all inputs	-0.5	$V_{DD} + 0.5$	V
storage temperature	$T_{stg}$	-	-65	+150	°C
total power dissipation	$P_{tot}$	-	-	500	mW
device dissipation	$P$	per output transistor	-	100	mW
Soldering temperature	$T_L$	10s	DIP	245	°C
			SOP/TSSOP	260	°C

#### 3.2、Recommended Operating Conditions

( $T_{amb} = 25^\circ\text{C}$ ;  $R_L = 10\text{k}\Omega$ ;  $C_L = 50\text{pF}$ ;  $\bar{E} = V_{DD}$ ;  $V_{is} = V_{DD} = 5V$ .)

Parameter	Symbol	Conditions	Min.	Typ.	Max.	Unit
supply voltage	$V_{DD}$	-	3	5	9	V
ambient temperature	$T_{amb}$	in free air	-40	-	+125	°C
supply voltage	$V_{EE}$	-	-6.0	-	0	V
supply voltage	$V_{DD} - V_{EE}$	-	3.0	-	9.0	V
input voltage	$V_I$	-	0	-	$V_{DD}$	V
Disable output time (High level → turn off)	$t_{PHZ}$	$\bar{E}$ to Z or $\bar{E}$ to $Y_n$	-	85	170	ns
Disable output time (Low level → turn off)	$t_{PLZ}$	$\bar{E}$ to Z or $\bar{E}$ to $Y_n$	-	115	230	ns
Enable output time (turn off → high/low level)	$t_{PZH}, t_{PZL}$	-	-	40	80	ns
input capacitance	$C_I$	-	-	-	7.5	pF





### 3.3、Electrical Characteristics

#### 3.3.1、DC Characteristics 1

( $T_{amb}=25^{\circ}\text{C}$ , voltages are referenced to  $V_{SS}$  (ground=0V), unless otherwise specified.)

Parameter	Symbol	Conditions (V)	$T_{amb}=25^{\circ}\text{C}$			Unit	
			Min.	Typ.	Max.		
supply current	$I_{DD}$	$V_I=V_{DD}$ or $V_{SS}, I_O=0\text{A}$	$V_{DD}=5\text{V}$	-	-	20	$\mu\text{A}$
			$V_{DD}=9\text{V}$	-	-	40	$\mu\text{A}$
HIGH-level input voltage	$V_{IH}$	$ I_O <1\mu\text{A}$	$V_{DD}=5\text{V}$	3.5	-	-	V
			$V_{DD}=9\text{V}$	7.0	-	-	V
LOW-level input voltage	$V_{IL}$	$ I_O <1\mu\text{A}$	$V_{DD}=5\text{V}$	-	-	1.5	V
			$V_{DD}=9\text{V}$	-	-	3.0	V
input leakage current	$I_I$	$V_I=0\text{V}$ or $9\text{V}, V_{DD}=9\text{V}$	-	-	1.0	$\mu\text{A}$	
3 state output leakage current	$I_{OZ}$	$V_{DD}=9\text{V}$	output to $V_{DD}$	-	-	1.6	$\mu\text{A}$
			output to $V_{SS}$	-	-	-1.6	$\mu\text{A}$
ON resistance (rail)	$R_{ON}$	$V_{IS}=0\text{V}$ to $V_{DD}-V_{EE}$	$V_{DD}-V_{EE}=5\text{V}$	-	350	2500	$\Omega$
			$V_{DD}-V_{EE}=9\text{V}$	-	80	245	$\Omega$
		$V_{IS}=0\text{V}$	$V_{DD}-V_{EE}=5\text{V}$	-	115	340	$\Omega$
			$V_{DD}-V_{EE}=9\text{V}$	-	50	160	$\Omega$
		$V_{IS}=V_{DD}-V_{EE}$	$V_{DD}-V_{EE}=5\text{V}$	-	120	365	$\Omega$
			$V_{DD}-V_{EE}=9\text{V}$	-	65	200	$\Omega$
ON resistance mismatch between channels	$\Delta R_{ON}$	$V_{IS}=0\text{V}$ to $V_{DD}-V_{EE}$	$V_{DD}-V_{EE}=5\text{V}$	-	25	-	$\Omega$
			$V_{DD}-V_{EE}=9\text{V}$	-	10	-	$\Omega$
OFF-state leakage current	$I_{S(OFF)}$	$V_{SS}=V_{EE}, V_{DD}-V_{EE}=9\text{V}$	all channel off; $\bar{E}=V_{DD}$	-	-	1.0	$\mu\text{A}$
			any channel; $\bar{E}=V_{SS}$	-	-	1.0	$\mu\text{A}$

#### 3.3.2、DC Characteristics 2

( $T_{amb}=-40^{\circ}\text{C}$  to  $+85^{\circ}\text{C}$ , voltages are referenced to  $V_{SS}$  (ground=0V), unless otherwise specified.)

Parameter	Symbol	Conditions (V)	$T_{amb}=-40^{\circ}\text{C}$		$T_{amb}=+85^{\circ}\text{C}$		Unit	
			Min.	Max.	Min.	Max.		
supply current	$I_{DD}$	$V_I=V_{DD}$ or $V_{SS}, I_O=0\text{A}$	$V_{DD}=5\text{V}$	-	20	-	150	$\mu\text{A}$
			$V_{DD}=9\text{V}$	-	40	-	300	$\mu\text{A}$
HIGH-level input voltage	$V_{IH}$	$ I_O <1\mu\text{A}$	$V_{DD}=5\text{V}$	3.5	-	3.5	-	V
			$V_{DD}=9\text{V}$	7.0	-	7.0	-	V
LOW-level input voltage	$V_{IL}$	$ I_O <1\mu\text{A}$	$V_{DD}=5\text{V}$	-	1.5	-	1.5	V
			$V_{DD}=9\text{V}$	-	3.0	-	3.0	V
input leakage current	$I_I$	$V_I=0\text{V}$ or $9\text{V}, V_{DD}=9\text{V}$	-	1.0	-	1.0	$\mu\text{A}$	
3 state output leakage current	$I_{OZ}$	$V_{DD}=9\text{V}$	output to $V_{DD}$	-	1.6	-	12.0	$\mu\text{A}$
			output to $V_{SS}$	-	-1.6	-	-12.0	$\mu\text{A}$



### 3.3.3、DC Characteristics 3

( $T_{amb} = -40^{\circ}\text{C}$  to  $+125^{\circ}\text{C}$ , voltages are referenced to  $V_{SS}$  (ground=0V), unless otherwise specified.)

Parameter	Symbol	Conditions (V)	$T_{amb} = -40^{\circ}\text{C}$		$T_{amb} = +125^{\circ}\text{C}$		Unit	
			Min.	Max.	Min.	Max.		
supply current	$I_{DD}$	$V_I = V_{DD}$ or $V_{SS}, I_O = 0\text{A}$	$V_{DD} = 5\text{V}$	-	20	-	150	$\mu\text{A}$
			$V_{DD} = 9\text{V}$	-	40	-	300	$\mu\text{A}$
HIGH-level input voltage	$V_{IH}$	$ I_O  < 1\mu\text{A}$	$V_{DD} = 5\text{V}$	3.5	-	3.5	-	V
			$V_{DD} = 9\text{V}$	7.0	-	7.0	-	V
LOW-level input voltage	$V_{IL}$	$ I_O  < 1\mu\text{A}$	$V_{DD} = 5\text{V}$	-	1.5	-	1.5	V
			$V_{DD} = 9\text{V}$	-	3.0	-	3.0	V
input leakage current	$I_I$	$V_I = 0\text{V}$ or $9\text{V}, V_{DD} = 9\text{V}$		-	1.0	-	1.0	$\mu\text{A}$
3 state output leakage current	$I_{OZ}$	$V_{DD} = 9\text{V}$	output to $V_{DD}$	-	1.6	-	12.0	$\mu\text{A}$
			output to $V_{SS}$	-	-1.6	-	-12.0	$\mu\text{A}$

### 3.3.4、AC Characteristics 1

( $T_{amb} = 25^{\circ}\text{C}$ ,  $V_{EE} = V_{SS} = 0\text{V}$ ,  $t_r, t_f \leq 20\text{ns}$ ,  $C_L = 50\text{pF}$ ,  $R_L = 10\text{k}\Omega$ , unless otherwise specified.)

Parameter	Symbol	Conditions	Min.	Typ.	Max.	Unit	
HIGH to LOW propagation delay time	$t_{PHL}$	Yn to Z; Z to Yn; see Figure 7	$V_{DD} = 5\text{V}$	-	15	30	ns
			$V_{DD} = 9\text{V}$	-	5	10	ns
		Sn to Yn, Z; see Figure 8	$V_{DD} = 5\text{V}$	-	150	300	ns
			$V_{DD} = 9\text{V}$	-	60	120	ns
LOW to HIGH propagation delay	$t_{PLH}$	Yn to Z; Z to Yn; see Figure 7	$V_{DD} = 5\text{V}$	-	15	30	ns
			$V_{DD} = 9\text{V}$	-	5	10	ns
		Sn to Yn, Z; see Figure 8	$V_{DD} = 5\text{V}$	-	150	300	ns
			$V_{DD} = 9\text{V}$	-	65	130	ns
HIGH to OFF-state propagation delay	$t_{PHZ}$	$\bar{E}$ to Yn, Z; see Figure 9	$V_{DD} = 5\text{V}$	-	120	240	ns
			$V_{DD} = 9\text{V}$	-	90	180	ns
LOW to OFF-state propagation delay	$t_{PLZ}$	$\bar{E}$ to Yn, Z; see Figure 9	$V_{DD} = 5\text{V}$	-	145	290	ns
			$V_{DD} = 9\text{V}$	-	120	240	ns
OFF-state to HIGH propagation delay	$t_{PZH}$	$\bar{E}$ to Yn, Z; see Figure 9	$V_{DD} = 5\text{V}$	-	140	280	ns
			$V_{DD} = 9\text{V}$	-	55	110	ns
OFF-state to LOW propagation delay	$t_{PZL}$	$\bar{E}$ to Yn, Z; see Figure 9	$V_{DD} = 5\text{V}$	-	140	280	ns
			$V_{DD} = 9\text{V}$	-	55	110	ns



### 3.3.5、AC Characteristics 2

( $T_{amb}=25^{\circ}C$ ,  $V_{EE}=V_{SS}=0V$ ,  $V_I=0.5V_{DD}$  (p-p), unless otherwise specified.)

Parameter	Symbol	Conditions	Min.	Typ.	Max.	Unit	
Square wave distortion	$d_{sin}$	see Figure 10; $R_L=10k\Omega$ ; $C_L=15pF$ ; channel ON; $f_i=1kHz$	$V_{DD}=5V$	0.25	-	-	%
			$V_{DD}=9V$	0.04	-	-	%
any two channel crosstalk	$f_{ct}$	$V_{DD}=9V$ , see note2	1	-	-	MHz	
crosstalk voltage ( $\bar{E}$ to Sn or Yn to Z)	$V_{ct}$	see Figure 11; $R_L=10k\Omega$ ; $C_L=15pF$ ; $\bar{E}$ or Sn= $V_{DD}$ (square-wave)	50	-	-	mV	
OFF frequency	$f_{OFF}$	$V_{DD}=9V$ , see note3	1	-	-	MHz	
conduction frequency	$f_{ON}$	$V_{DD}=5V$ , see note4	13	-	-	MHz	
		$V_{DD}=9V$ , see note4	40	-	-	MHz	

Note:

- [1]  $f_i$  is biased at  $0.5V_{DD}$ ;  $V_I=0.5V_{DD}$  (p-p).
- [2]  $R_L=1k\Omega$ ;  $20\log V_{os}/V_{is}=-50dB$ , see Figure 12.
- [3]  $R_L=1k\Omega$ ;  $C_L=5pF$ , channel off,  $20\log V_{os}/V_{is}=-50dB$ , see Figure 10.
- [4]  $R_L=1k\Omega$ ;  $C_L=5pF$ , channel on,  $20\log V_{os}/V_{is}=-3dB$ , see Figure 10.

## 4、Testing Circuit

### 4.1、AC Testing Circuit 1

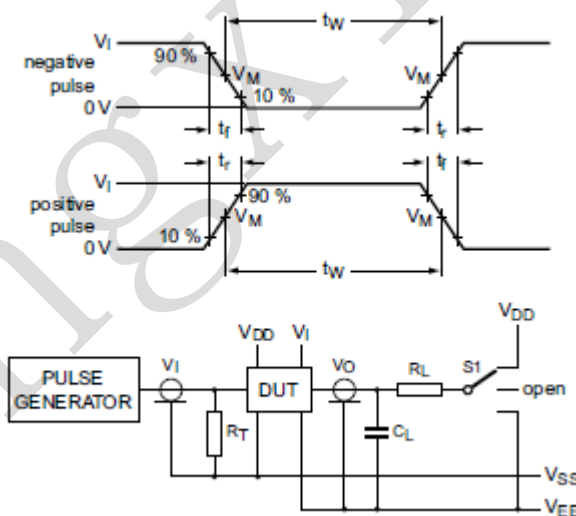

Figure 6. Test circuit for switching times

Definitions for test circuit:

DUT=Device Under Test.

$C_L$ =Load capacitance including jig and probe capacitance.

$R_T$ =Termination resistance should be equal to the output impedance  $Z_o$  of the pulse generator.

$R_L$ =Load resistance.



## 4.2、AC Testing Waveforms

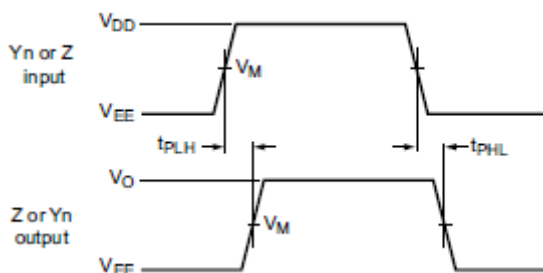

Figure 7. Yn, Z to Z, Yn propagation delays

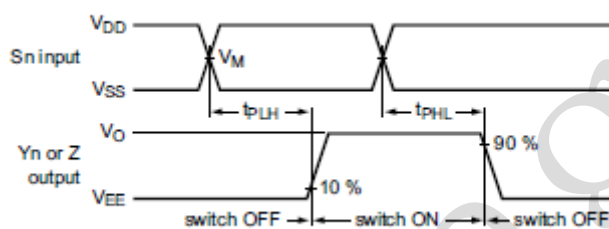

Figure 8. Sn to Yn, Z propagation delays

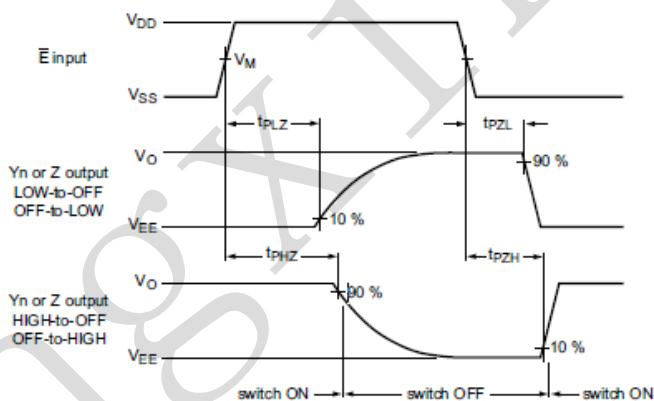

Figure 9. Enable and disable times

## 4.3、AC Testing Circuit 2

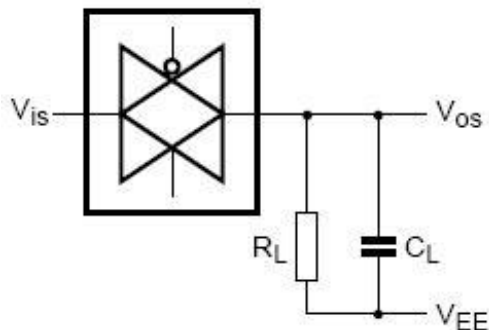

Figure 10. Square wave distortion degree of cut-off frequency and conduction frequency test pattern

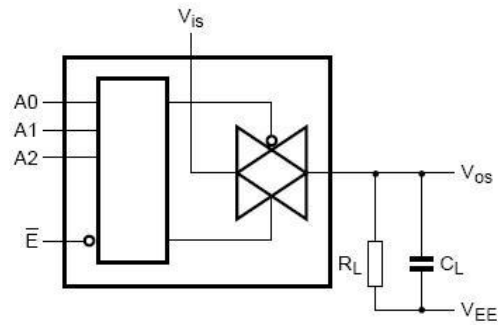

Figure 11. Crosstalk logical input/output test

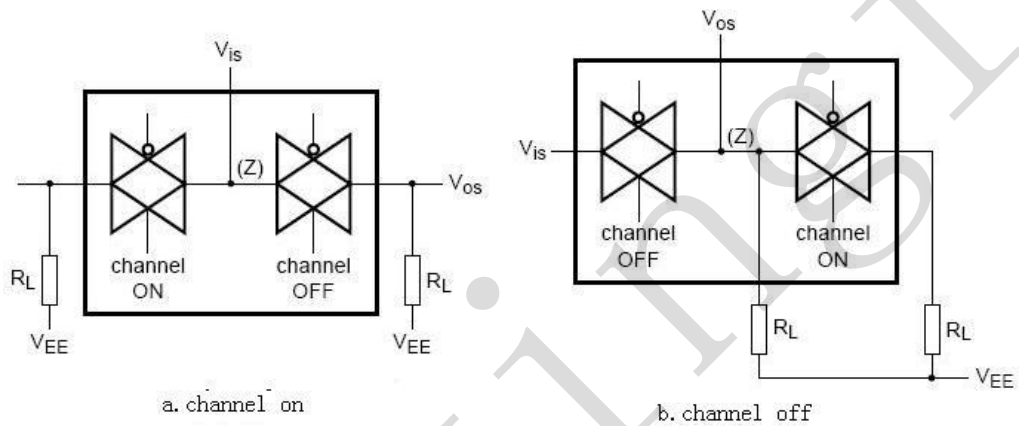

Figure 12. Inter channel Crosstalk

#### 4.4. Measurement Points

Supply voltage	Input	Output
$V_{DD}$	$V_M$	$V_M$
3V to 9V	$0.5 \times V_{DD}$	$0.5 \times V_{DD}$

#### 4.5. Test Data

Test	Input		Load		Switch
	$V_{is}$	$t_r, t_f$	$C_L$	$R_L$	
$t_{PHL}$	$V_{EE}$	20ns	50pF	10k $\Omega$	$V_{DD}$
$t_{PLH}$	$V_{DD}$	20ns	50pF	10k $\Omega$	$V_{EE}$
$t_{PZH}, t_{PHZ}$	$V_{DD}$	20ns	50pF	10k $\Omega$	$V_{EE}$
$t_{PZL}, t_{PLZ}$	$V_{EE}$	20ns	50pF	10k $\Omega$	$V_{DD}$
others	pulse	20ns	50pF	10k $\Omega$	open



## 5、Package Information

### 5.1、DIP16

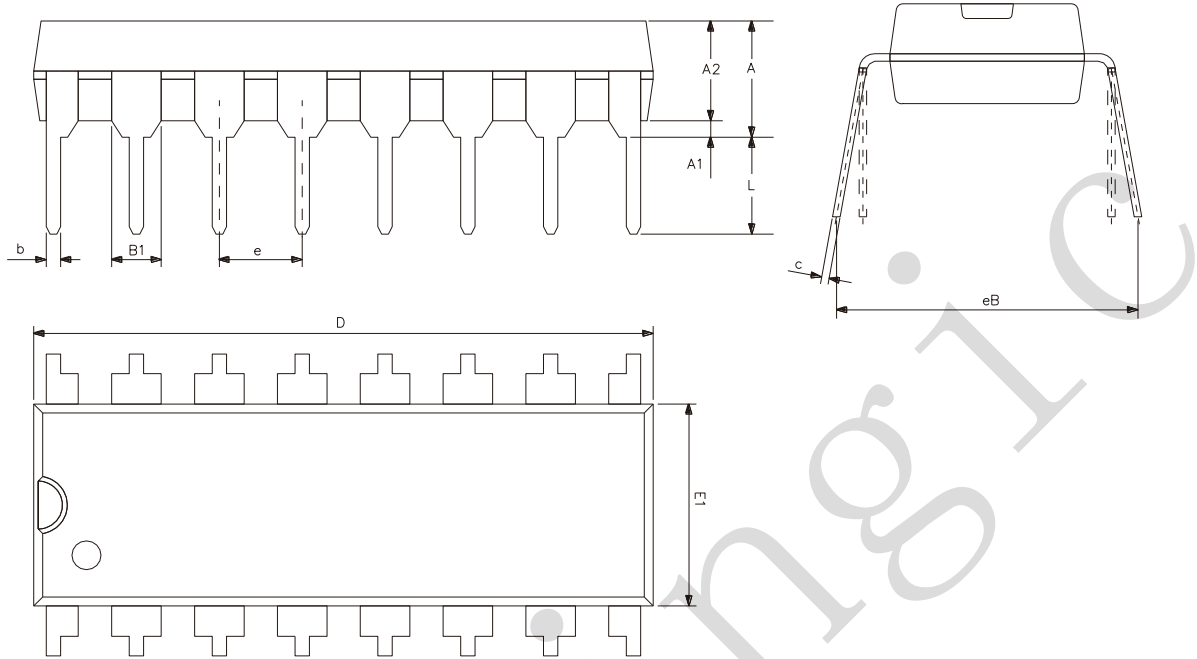

Symbol	Dimensions (mm)	
	Min.	Max.
A2	3.20	3.60
A1	0.51	-
A	3.60	5.33
L	3.00	3.60
b	0.36	0.56
B1	1.52	
D	18.80	19.94
E1	6.20	6.60
e	2.54	
c	0.20	0.36
eB	7.62	9.30



### 5.2、SOP16

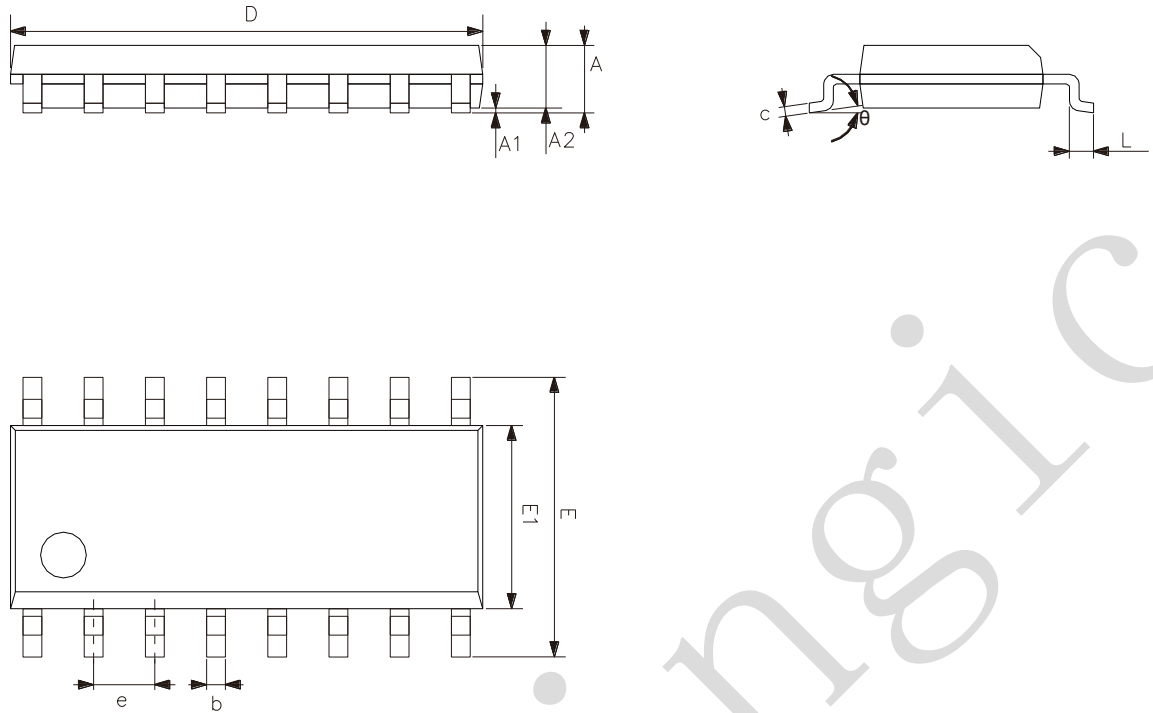

Symbol	Dimensions (mm)	
	Min.	Max.
A	1.35	1.80
A1	0.10	0.25
A2	1.25	1.55
b	0.33	0.51
c	0.19	0.25
D	9.50	10.10
E	5.80	6.30
E1	3.70	4.10
e	1.27	
L	0.35	0.89
$\theta$	0°	8°



### 5.3、TSSOP16

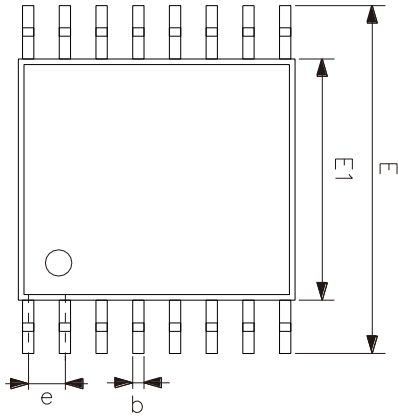
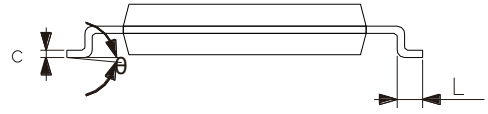
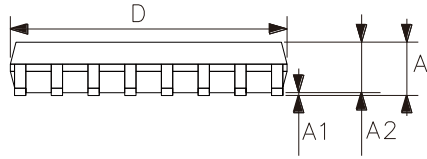

Symbol	Dimensions (mm)	
	Min.	Max.
A	-	1.20
A1	0.05	0.15
A2	0.80	1.05
b	0.19	0.30
c	0.09	0.20
D	4.90	5.10
E1	4.30	4.50
E	6.20	6.60
e	0.65	
L	0.45	0.75
$\theta$	0°	8°





## 6、 Statements And Notes

### 6.1、 The name and content of Hazardous substances or Elements in the product

Part name	Hazardous substances or Elements									
	Lead and lead compounds	Mercury and mercury compounds	Cadmium and cadmium compounds	Hexavalent chromium compounds	Polybrominated biphenyls	Polybrominated biphenyl ethers	Dibutyl phthalate	Butylbenzyl phthalate	Di-2-ethylhexyl phthalate	Diisobutyl phthalate
Lead frame	○	○	○	○	○	○	○	○	○	○
Plastic resin	○	○	○	○	○	○	○	○	○	○
Chip	○	○	○	○	○	○	○	○	○	○
The lead	○	○	○	○	○	○	○	○	○	○
Plastic sheet installed	○	○	○	○	○	○	○	○	○	○
explanation	○: Indicates that the content of hazardous substances or elements in the detection limit of the following the SJ/T11363-2006 standard. ×: Indicates that the content of hazardous substances or elements exceeding the SJ/T11363-2006 Standard limit requirements.									

### 6.2、 Notes

We Recommend you to read this chapter carefully before using this product.

The information in this chapter is provided for reference only and Lingxing disclaims any express or implied warranties, including but not limited to applicability, special application or non-infringement of third party rights.

This product is not suitable for critical equipment such as life-saving, life-sustaining or safety equipment. It is also not suitable for applications that may result in personal injury, death, or serious property or environmental damage due to product malfunction or failure. Lingxing will not be liable for any damages incurred by the customers at their own risk for such applications.

The customer is responsible for conducting all necessary tests Lingxing's application to avoid failure in the application or the application of the customer's third party users. Lingxing does not accept any liability.

The Company reserves the right to change or improve the information published in this chapter at any time. The information in this chapter are subject to change without notice. We recommend the customer to consult our sales staff before purchasing.

Please obtain related materials form Lingxing's regular channels and we are not responsible for its content if it is provided by sources other than our company.

In case of any conflict between the Chinese and English version, the version is subject to the Chinese one.

## X-ON Electronics

Largest Supplier of Electrical and Electronic Components

*Click to view similar products for [Analogue Switch ICs](#) category:*

*Click to view products by [lingxingic](#) manufacturer:*

Other Similar products are found below :

[FSA3051TMX](#) [NLAS5223BLMNR2G](#) [NLX2G66DMUTCG](#) [425541DB](#) [DG403DY](#) [099044FB](#) [MAX4762ETB+](#) [NLAS3799BMNR2G](#)  
[NLAS5123MNR2G](#) [ISL84684IR](#) [PI5A4157CEX](#) [PI5A4599BCEX](#) [NLAS4717EPFCT1G](#) [PI5A3167CCEX](#) [SLAS3158MNR2G](#) [PI5A392AQE](#)  
[ADG714BCPZ-REEL7](#) [DG333ALDW-T1-E3](#) [ISL43113IB](#) [ISL43140IB](#) [ISL43140IBZ-T](#) [ISL43143IR](#) [ISL43L120IR](#) [ISL43L121IR](#)  
[ISL43L122IR](#) [ISL43L220IR](#) [ISL43L410IR](#) [ISL43L420IR](#) [ISL43L710IR](#) [ISL43L711IR](#) [ISL43L712IR](#) [ISL84053IA](#) [ISL84514IB](#)  
[ISL84516IB](#) [ISL84684IUZ-T](#) [LNLASB3157DFT2G](#) [NLAS324US](#) [NLASTV4599DFT2G](#) [ADG842YKSZ-REEL7](#) [WAS4766C-9/TR](#)  
[WAS7227Q-10/TR](#) [WAS4646C-36/TR](#) [WAS4735Q-16/TR](#) [BL1532TQFN](#) [RS2233YS16](#) [CH483M](#) [TMUX7236RUMR](#) [ADG836YRMZ-](#)  
[REEL](#) [MS3494](#) [ADG412BR-REEL7](#)