



灵星芯微 芯片经营

深圳市灵星芯微电子科技有限公司

Shenzhen Lingxing Microelectronics Technology Co., Ltd.

Tab: 835-12-B4

Number: CD4060-AX-LJ-D020EN

CD4060 (LX)

14-stage Ripple-carry Binary Counter/Divider and Oscillator

Product Specification

Specification Revision History:

Version	Date	Description
2022-06-A1	2022-06	New
2023-04-B1	2023-04	Update the template



Contents

1、 General Description.....	3
2、 Block Diagram And Pin Description	5
2.1、 Block Diagram	5
2.2、 Pin Configurations.....	5
2.3、 Pin Description	6
2.4、 Function Table.....	6
3、 Electrical Parameter	6
3.1、 Absolute Maximum Ratings.....	6
3.2、 Recommended Operating Conditions	7
3.3、 Electrical Characteristics	7
3.3.1、 DC Characteristics 1	7
3.3.2、 DC Characteristics 2	8
3.3.3、 DC Characteristics 3	9
3.3.4、 AC Characteristics 1	10
3.3.5、 AC Characteristics 2	11
4、 Testing Circuit	12
4.1、 AC Testing Circuit	12
4.2、 AC Testing Waveforms.....	12
4.3、 Measurement Points	12
4.4、 Test Data	12
5、 Package Information	13
5.1、 DIP16	13
5.2、 SOP16	14
5.3、 TSSOP16.....	15
6、 Statements And Notes	16
6.1、 The name and content of Hazardous substances or Elements in the product.....	16
6.2、 Notes	16



1、General Description

CD4060 is a 14-stage ripple-carry binary counter/divider and oscillator with three oscillator terminals (RS, REXT and CEXT), ten buffered outputs (Q3 to Q9 and Q11 to Q13) and an overriding asynchronous master reset input (MR).

The oscillator configuration allows design of either RC or crystal oscillator circuits. The oscillator may be replaced by an external clock signal at input RS. The counter advances on the negative-going transition of RS. A HIGH level on MR resets the counter (Q3 to Q9 and Q11 to Q13=LOW), independent of other input conditions.

It operates over a recommended V_{DD} power supply range of 3V to 15V referenced to V_{SS} (usually ground). Unused inputs must be connected to V_{DD} , V_{SS} , or another input.

Features:

- Wide supply voltage range from 3V to 15V
- Tolerant of slow clock rise and fall times
- Fully static operation
- 5V, 10V, and 15V parametric ratings
- Standardized symmetrical output characteristics
- Inputs and outputs are protected against electrostatic effects
- Specified from -40°C to +125°C
- Packaging information: DIP16/SOP16/TSSOP16



Ordering Information:

Tube packing specifications:

Part number	Packaging form	Marking code	Tube quantity	Boxed tube quantity	Boxed quantity	Notes
CD4060BE (LX)	DIP16	CD4060BE	25 PCS/tube	40 tube/box	1000 PCS/box	Dimensions of plastic enclosure: 19.0mm×6.4mm Pin spacing: 2.54mm
CD4060BM (LX)	SOP16	CD4060BM	50 PCS/tube	200 tube/box	10000 PCS/box	Dimensions of plastic enclosure: 10.0mm×3.9mm Pin spacing: 1.27mm
CD4060PW (LX)	TSSOP16	CD4060	96 PCS/tube	200 tube/box	19200 PCS/box	Dimensions of plastic enclosure: 5.0mm×4.4mm Pin spacing: 0.65mm

Reel packing specifications:

Part number	Packaging form	Marking code	Reel quantity	Boxed reel quantity	Notes
CD4060BM (LX)	SOP16	CD4060BM	4000 PCS/reel	8000 PCS/box	Dimensions of plastic enclosure: 10.0mm×3.9mm Pin spacing:1.27mm
CD4060PW (LX)	TSSOP16	CD4060	5000 PCS/reel	10000 PCS/box	Dimensions of plastic enclosure: 5.0mm×4.4mm Pin spacing:0.65mm

Note: If the physical information is inconsistent with the ordering information, please refer to the actual product.



2、Block Diagram And Pin Description

2.1、Block Diagram

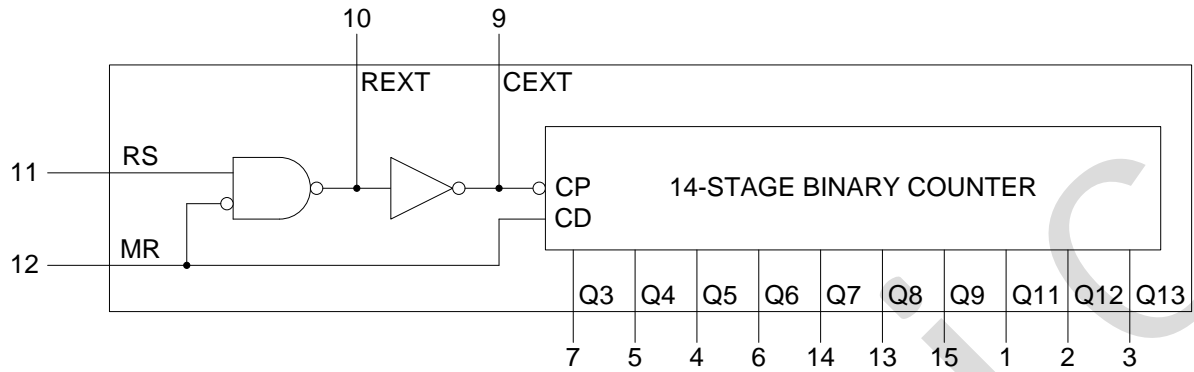

Figure 1. Functional diagram

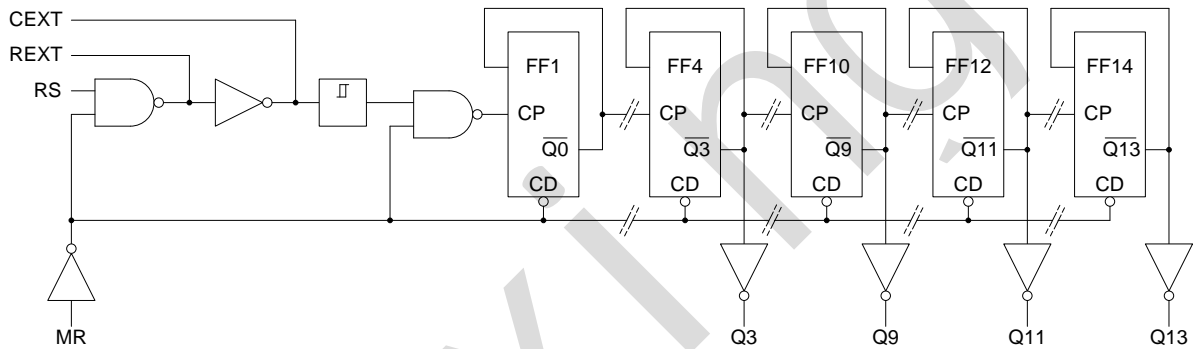
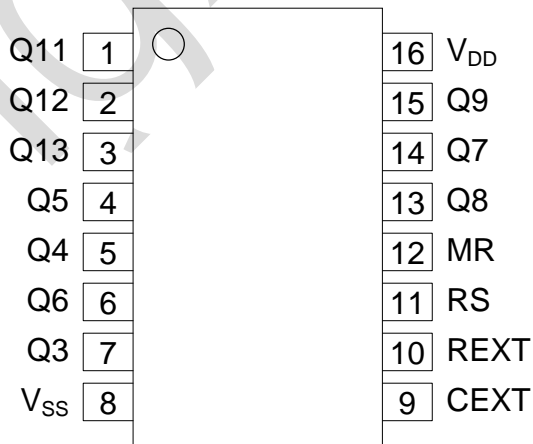

Figure 2. Logic diagram

2.2、Pin Configurations





2.3、Pin Description

Pin No.	Pin Name	Description
1	Q11	counter output
2	Q12	counter output
3	Q13	counter output
4	Q5	counter output
5	Q4	counter output
6	Q6	counter output
7	Q3	counter output
8	V _{SS}	ground (0V)
9	CEXT	external capacitor connection
10	REXT	oscillator pin
11	RS	clock input/oscillator pin
12	MR	master reset
13	Q8	counter output
14	Q7	counter output
15	Q9	counter output
16	V _{DD}	supply voltage

2.4、Function Table

Input		Output
RS	MR	Q3 to Q9 and Q11 to Q13
↑	L	no change
↓	L	count
X	H	L

Note: H=HIGH voltage level; L=LOW voltage level; X=don't care; ↑=LOW-to-HIGH clock transition.

3、Electrical Parameter

3.1、Absolute Maximum Ratings

(Voltages are referenced to V_{SS} (ground=0V), unless otherwise specified.)

Parameter	Symbol	Conditions	Min.	Max.	Unit
supply voltage	V _{DD}	-	-0.5	+18	V
DC input current	I _{IK}	any one input	-	±10	mA
input voltage	V _I	all inputs	-0.5	V _{DD} +0.5	V
storage temperature	T _{stg}	-	-65	+150	°C
total power dissipation	P _{tot}	-	-	500	mW
device dissipation	P	per output transistor	-	100	mW
soldering temperature	T _L	10s	DIP	245	°C
			SOP/TSSOP	260	°C



3.2、Recommended Operating Conditions

Parameter	Symbol	Conditions	Min.	Typ.	Max.	Unit	
supply voltage	V_{DD}	-	3	-	15	V	
ambient temperature	T_{amb}	in free air	-40	-	+125	°C	
input pulse width	t_w	f=100kHz	$V_{DD}=5V$	100	-	-	ns
			$V_{DD}=10V$	40	-	-	ns
			$V_{DD}=15V$	30	-	-	ns
input pulse rise and fall time	t_{rIN}, t_{fIN}	$V_{DD}=5V$	unlimited			-	
		$V_{DD}=10V$	unlimited			-	
		$V_{DD}=15V$	unlimited			-	
input pulse frequency	f_{RS}	external pulse source	$V_{DD}=5V$	-	-	3.5	MHz
			$V_{DD}=10V$	-	-	8	MHz
			$V_{DD}=15V$	-	-	12	MHz
reset pulse width	t_{wR}	$V_{DD}=5V$	120	-	-	ns	
		$V_{DD}=10V$	60	-	-	ns	
		$V_{DD}=15V$	40	-	-	ns	

3.3、Electrical Characteristics

3.3.1、DC Characteristics 1

($T_{amb}=25^{\circ}C$, voltages are referenced to V_{SS} (ground=0V), unless otherwise specified.)

Parameter	Symbol	Conditions (V)			$T_{amb}=25^{\circ}C$			Unit
		V_O	V_{IN}	V_{DD}	Min.	Typ.	Max.	
supply current	I_{DD}	-	0, 5	5	-	-	5	uA
		-	0, 10	10	-	-	10	uA
		-	0, 15	15	-	-	20	uA
LOW-level output current	I_{OL}	0.4	0, 5	5	0.51	1	-	mA
		0.5	0, 10	10	1.3	2.6	-	mA
		1.5	0, 15	15	3.4	6.8	-	mA
HIGH-level output current	I_{OH}	4.6	0, 5	5	-0.51	-1	-	mA
		2.5	0, 5	5	-1.6	-3.2	-	mA
		9.5	0, 10	10	-1.3	-2.6	-	mA
		13.5	0, 15	15	-3.4	-6.8	-	mA
LOW-level output voltage	V_{OL}	-	0, 5	5	-	0	0.05	V
		-	0, 10	10	-	0	0.05	V
		-	0, 15	15	-	0	0.05	V
HIGH-level output voltage	V_{OH}	-	0, 5	5	4.95	5	-	V
		-	0, 10	10	9.95	10	-	V
		-	0, 15	15	14.95	15	-	V
LOW-level input voltage	V_{IL}	0.5, 4.5	-	5	-	-	1.5	V
		1, 9	-	10	-	-	3	V
		1.5, 13.5	-	15	-	-	4	V
HIGH-level input voltage	V_{IH}	0.5, 4.5	-	5	3.5	-	-	V
		1, 9	-	10	7	-	-	V
		1.5, 13.5	-	15	11	-	-	V



input leakage current	I_I	-	0, 15	15	-	-	± 1	μA
-----------------------	-------	---	-------	----	---	---	---------	---------

3.3.2、DC Characteristics 2

($T_{amb} = -40^{\circ}C$ to $+85^{\circ}C$, voltages are referenced to V_{SS} (ground=0V), unless otherwise specified.)

Parameter	Symbol	Conditions (V)			$T_{amb} = -40^{\circ}C$		$T_{amb} = +85^{\circ}C$		Unit
		V_O	V_{IN}	V_{DD}	Min.	Max.	Min.	Max.	
supply current	I_{DD}	-	0, 5	5	-	5	-	150	μA
		-	0, 10	10	-	10	-	300	μA
		-	0, 15	15	-	20	-	600	μA
LOW-level output current	I_{OL}	0.4	0, 5	5	0.61	-	0.42	-	mA
		0.5	0, 10	10	1.5	-	1.1	-	mA
		1.5	0, 15	15	4	-	2.8	-	mA
HIGH-level output current	I_{OH}	4.6	0, 5	5	-0.61	-	-0.42	-	mA
		2.5	0, 5	5	-1.8	-	-1.3	-	mA
		9.5	0, 10	10	-1.5	-	-1.1	-	mA
		13.5	0, 15	15	-4	-	-2.8	-	mA
LOW-level output voltage	V_{OL}	-	0, 5	5	-	0.05	-	0.05	V
		-	0, 10	10	-	0.05	-	0.05	V
		-	0, 15	15	-	0.05	-	0.05	V
HIGH-level output voltage	V_{OH}	-	0, 5	5	4.95	-	4.95	-	V
		-	0, 10	10	9.95	-	9.95	-	V
		-	0, 15	15	14.95	-	14.95	-	V
LOW-level input voltage	V_{IL}	0.5, 4.5	-	5	-	1.5	-	1.5	V
		1, 9	-	10	-	3	-	3	V
		1.5, 13.5	-	15	-	4	-	4	V
HIGH-level input voltage	V_{IH}	0.5, 4.5	-	5	3.5	-	3.5	-	V
		1, 9	-	10	7	-	7	-	V
		1.5, 13.5	-	15	11	-	11	-	V
input leakage current	I_I	-	0, 15	15	-	± 1	-	± 1	μA



3.3.3、DC Characteristics 3

($T_{amb}=-40^{\circ}\text{C}$ to $+125^{\circ}\text{C}$, voltages are referenced to V_{SS} (ground=0V), unless otherwise specified.)

Parameter	Symbol	Conditions (V)			$T_{amb}=-40^{\circ}\text{C}$		$T_{amb}=+125^{\circ}\text{C}$		Unit
		V_O	V_{IN}	V_{DD}	Min.	Max.	Min.	Max.	
supply current	I_{DD}	-	0, 5	5	-	5	-	150	uA
		-	0, 10	10	-	10	-	300	uA
		-	0, 15	15	-	20	-	600	uA
LOW-level output current	I_{OL}	0.4	0, 5	5	0.61	-	0.36	-	mA
		0.5	0, 10	10	1.5	-	0.9	-	mA
		1.5	0, 15	15	4	-	2.4	-	mA
HIGH-level output current	I_{OH}	4.6	0, 5	5	-0.61	-	-0.36	-	mA
		2.5	0, 5	5	-1.8	-	-1.15	-	mA
		9.5	0, 10	10	-1.5	-	-0.9	-	mA
		13.5	0, 15	15	-4	-	-2.4	-	mA
LOW-level output voltage	V_{OL}	-	0, 5	5	-	0.05	-	0.05	V
		-	0, 10	10	-	0.05	-	0.05	V
		-	0, 15	15	-	0.05	-	0.05	V
HIGH-level output voltage	V_{OH}	-	0, 5	5	4.95	-	4.95	-	V
		-	0, 10	10	9.95	-	9.95	-	V
		-	0, 15	15	14.95	-	14.95	-	V
LOW-level input voltage	V_{IL}	0.5, 4.5	-	5	-	1.5	-	1.5	V
		1, 9	-	10	-	3	-	3	V
		1.5, 13.5	-	15	-	4	-	4	V
HIGH-level input voltage	V_{IH}	0.5, 4.5	-	5	3.5	-	3.5	-	V
		1, 9	-	10	7	-	7	-	V
		1.5, 13.5	-	15	11	-	11	-	V
input leakage current	I_I	-	0, 15	15	-	± 1	-	± 1	uA



3.3.4、AC Characteristics 1

($T_{amb}=25^{\circ}C$, $V_{SS}=0V$, $t_r, t_f=20ns$, $C_L=50pF$, $R_L=200k\Omega$, unless otherwise specified.)

Parameter	Symbol	Conditions	Min.	Typ.	Max.	Unit	
propagation delay time	t_{PHL}, t_{PLH}	RS to Q3 out; see Figure 4	$V_{DD}=5V$	-	370	740	ns
			$V_{DD}=10V$	-	150	300	ns
			$V_{DD}=15V$	-	100	200	ns
		Q _n to Q _{n+1} ; see Figure 4	$V_{DD}=5V$	-	100	200	ns
			$V_{DD}=10V$	-	50	100	ns
			$V_{DD}=15V$	-	40	80	ns
		MR to Q _n ; see Figure 4	$V_{DD}=5V$	-	180	360	ns
			$V_{DD}=10V$	-	80	160	ns
			$V_{DD}=15V$	-	50	100	ns
transition time	t_t	see Figure 4	$V_{DD}=5V$	-	100	200	ns
			$V_{DD}=10V$	-	50	100	ns
			$V_{DD}=15V$	-	40	80	ns
pulse width	t_w	minimum width; f=100kHz; RS HIGH;	$V_{DD}=5V$	-	50	100	ns
			$V_{DD}=10V$	-	20	40	ns
			$V_{DD}=15V$	-	15	30	ns
		minimum width; MR HIGH; see Figure 4	$V_{DD}=5V$	-	60	120	ns
			$V_{DD}=10V$	-	30	60	ns
			$V_{DD}=15V$	-	20	40	ns
input pulse rise and fall time	t_{rIN}, t_{fIN}	-	$V_{DD}=5V$	unlimited			-
			$V_{DD}=10V$				-
			$V_{DD}=15V$				-
maximum clock frequency	f_{max}	input RS; see Figure 4	$V_{DD}=5V$	3.5	7	-	MHz
			$V_{DD}=10V$	8	16	-	MHz
			$V_{DD}=15V$	12	24	-	MHz
input capacitance	C_I	any input	-	5	7.5	pF	

Note: t_t is the same as t_{TLH} and t_{THL} .



3.3.5、AC Characteristics 2

(RC Operation, $T_{amb}=25^{\circ}C$, $V_{SS}=0V$, $t_r, t_f=20ns$, $C_L=50pF$, $R_L=200k\Omega$, unless otherwise specified.)

Parameter	Symbol	Conditions	Min.	Typ.	Max.	Unit	
variation of frequency (unit to unit)	-	$C_X=200pF$ $R_S=560k\Omega$ $R_X=50k\Omega$	$V_{DD}=5V$	-	$23\pm 10\%$	-	kHz
			$V_{DD}=10V$	-	$24\pm 10\%$	-	kHz
			$V_{DD}=15V$	-	$25\pm 10\%$	-	kHz
variation of frequency with voltage change (same unit)	-	$C_X=200pF$ $R_S=560k\Omega$ $R_X=50k\Omega$	5V to 10V	-	1.5	-	kHz
			10V to 15V	-	0.5	-	kHz
R_X max	-	$C_X=10\mu F, V_{DD}=5V$	-	-	20	M Ω	
		$C_X=50\mu F, V_{DD}=10V$	-	-	20	M Ω	
		$C_X=10\mu F, V_{DD}=15V$	-	-	10	M Ω	
C_X max	-	$R_X=500k\Omega, V_{DD}=5V$	-	-	1000	μF	
		$R_X=300k\Omega, V_{DD}=10V$	-	-	50	μF	
		$R_X=300k\Omega, V_{DD}=15V$	-	-	50	μF	
Maximum oscillator frequency	-	$C_X=15pF$ $R_S=30k\Omega$ $R_X=15k\Omega$	$V_{DD}=10V$	530	650	810	kHz
			$V_{DD}=15V$	690	800	940	kHz
drive current at CEXT (for oscillator design)	I_{OL}	$V_O=0.4V, V_{DD}=5V$	0.16	0.35	-	mA	
		$V_O=0.5V, V_{DD}=10V$	0.42	0.8	-	mA	
		$V_O=1.5V, V_{DD}=15V$	1	2	-	mA	
	I_{OH}	$V_O=4.6V, V_{DD}=5V$	-0.16	-0.35	-	mA	
		$V_O=9.5V, V_{DD}=10V$	-0.42	-0.8	-	mA	
		$V_O=13.5V, V_{DD}=15V$	-1	-2	-	mA	

Note: RC oscillator applications are not recommended at supply voltages below 7V for $R_X < 50k\Omega$.



4、Testing Circuit

4.1、AC Testing Circuit

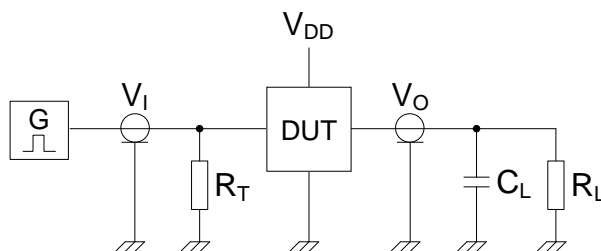

Figure 3. Test circuit for switching times

Definitions for test circuit:

DUT=Device Under Test.

C_L =Load capacitance including jig and probe capacitance.

R_T =Termination resistance should be equal to the output impedance Z_o of the pulse generator.

R_L = Load resistance.

4.2、AC Testing Waveforms

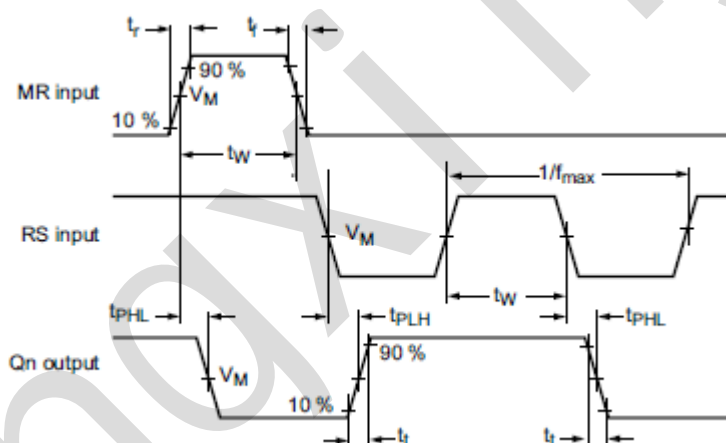

Figure 4. Waveforms showing propagation delays

4.3、Measurement Points

Supply voltage	Input	Output
V_{DD}	V_M	V_M
5V to 15V	$0.5 \times V_{DD}$	$0.5 \times V_{DD}$

4.4、Test Data

Supply voltage	Input		Load
V_{DD}	V_I	t_r, t_f	C_L
5V to 15V	V_{SS} or V_{DD}	$\leq 20\text{ns}$	50pF



灵星芯微 专注经营

5、Package Information

5.1、DIP16

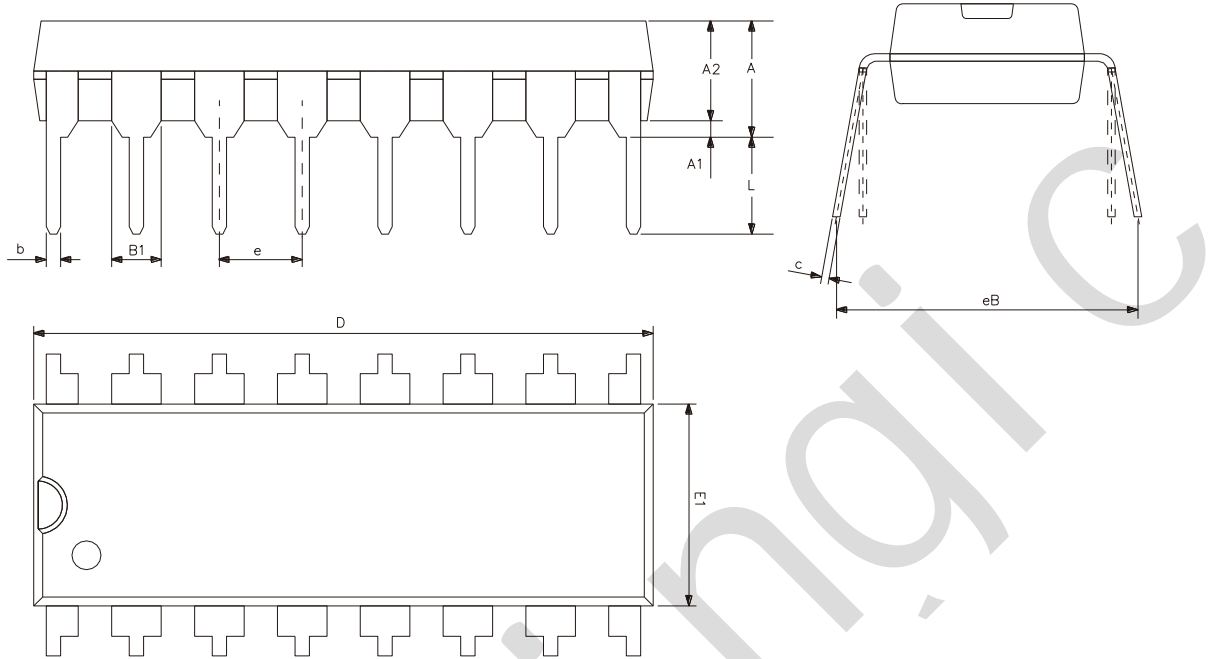

Symbol	Dimensions (mm)	
	Min.	Max.
A2	3.20	3.60
A1	0.51	-
A	3.60	5.33
L	3.00	3.60
b	0.36	0.56
B1	1.52	
D	18.80	19.94
E1	6.20	6.60
e	2.54	
c	0.20	0.36
eB	7.62	9.30



5.2、SOP16

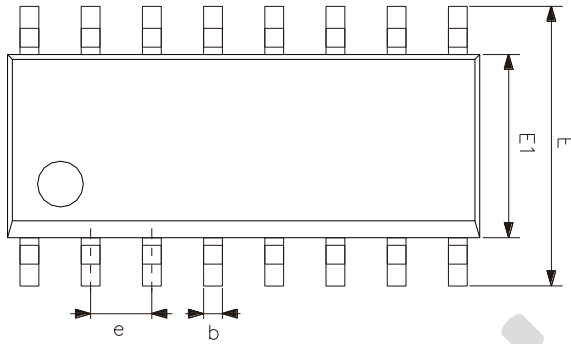
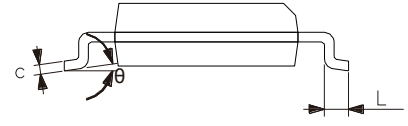
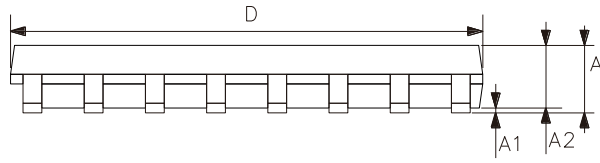

Symbol	Dimensions (mm)	
	Min.	Max.
A	1.35	1.80
A1	0.10	0.25
A2	1.25	1.55
b	0.33	0.51
c	0.19	0.25
D	9.50	10.10
E	5.80	6.30
E1	3.70	4.10
e	1.27	
L	0.35	0.89
θ	0°	8°



灵星芯微 专注经营

5.3、TSSOP16

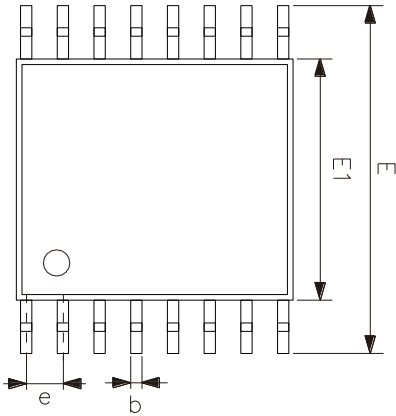
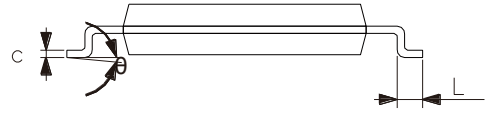
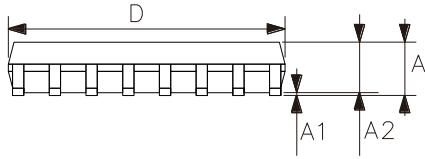

Symbol	Dimensions (mm)	
	Min.	Max.
A	-	1.20
A1	0.05	0.15
A2	0.80	1.05
b	0.19	0.30
c	0.09	0.20
D	4.90	5.10
E1	4.30	4.50
E	6.20	6.60
e	0.65	
L	0.45	0.75
θ	0°	8°



灵星芯微 集成电路

6、 Statements And Notes

6.1、 The name and content of Hazardous substances or Elements in the product

Part name	Hazardous substances or Elements									
	Lead and lead compounds	Mercury and mercury compounds	Cadmium and cadmium compounds	Hexavalent chromium compounds	Polybrominated biphenyls	Polybrominated biphenyl ethers	Dibutyl phthalate	Butylbenzyl phthalate	Di-2-ethylhexyl phthalate	Diisobutyl phthalate
Lead frame	○	○	○	○	○	○	○	○	○	○
Plastic resin	○	○	○	○	○	○	○	○	○	○
Chip	○	○	○	○	○	○	○	○	○	○
The lead	○	○	○	○	○	○	○	○	○	○
Plastic sheet installed	○	○	○	○	○	○	○	○	○	○
explanation	○: Indicates that the content of hazardous substances or elements in the detection limit of the following the SJ/T11363-2006 standard. ×: Indicates that the content of hazardous substances or elements exceeding the SJ/T11363-2006 Standard limit requirements.									

6.2、 Notes

We Recommend you to read this chapter carefully before using this product.

The information in this chapter is provided for reference only and Lingxing disclaims any express or implied warranties, including but not limited to applicability, special application or non-infringement of third party rights.

This product is not suitable for critical equipment such as life-saving, life-sustaining or safety equipment. It is also not suitable for applications that may result in personal injury, death, or serious property or environmental damage due to product malfunction or failure. Lingxing will not be liable for any damages incurred by the customers at their own risk for such applications.

The customer is responsible for conducting all necessary tests Lingxing's application to avoid failure in the application or the application of the customer's third party users. Lingxing does not accept any liability.

The Company reserves the right to change or improve the information published in this chapter at any time. The information in this chapter are subject to change without notice. We recommend the customer to consult our sales staff before purchasing.

Please obtain related materials form Lingxing's regular channels and we are not responsible for its content if it is provided by sources other than our company.

In case of any conflict between the Chinese and English version, the version is subject to the Chinese one.

X-ON Electronics

Largest Supplier of Electrical and Electronic Components

Click to view similar products for [Counter ICs](#) category:

Click to view products by [lingxingic](#) manufacturer:

Other Similar products are found below :

[CD4018BE](#) [CD4033BE](#) [CD4060BE](#) [CD4040BE](#) [NLV14040BDR2G](#) [RFDIP1607ALM9T21](#) [RFDIP1606L708D1T](#) [RFTIP2510T12A8Q1C](#)
[74HC161DT](#) [CD4028BM/TR](#) [CD4060DM/TR](#) [CD4022BE](#) [CD4060DMT/TR](#) [CD4020BE](#) [CD4060BMT/TR](#) [74HC192M/TR](#)
[CD4020BMT/TR](#) [CD4017CMT/TR](#) [74HC193M/TR](#) [CD4017CM/TR](#) [AiP74HC193SA16.TB](#) [CD4518BM/TR](#) [CD4060TA16.TB](#) [CD4060DE](#)
[CD4017CN](#) [CD4017BMT/TR](#) [U74HC4060G-S16-R](#) [CD4017SA.TB](#) [XD74LS160](#) [CD4017BM-MS](#) [CD4022BM/TR](#) [CD4022BMT/TR](#)
[CD4028BDRG](#) [CD4060BDRG](#) [CD4017DA.TB](#) [CD4520BDRG](#) [CD4520BM\(LX\)](#) [CD4518BM\(LX\)](#) [SN74HC393DR\(LX\)](#) [SN74HC393N\(LX\)](#)
[CD4060BM\(LX\)](#) [CD4060BE\(LX\)](#) [CD4518BE\(LX\)](#) [CD4520BE\(LX\)](#) [74VHC393FT\(BJ\)](#) [74VHC161FT\(BJ\)](#) [74VHC163FT\(BJ\)](#)
[74HC4040D.653](#) [74HC4060D.653](#) [74HCT4040D.653](#)