



灵星芯微 芯片经营

# CD4068 (LX) 8-input And Gate/Nand Gate

## Product Specification

### Specification Revision History:

Version	Date	Description
2022-06-A1	2022-06	New
2023-04-B1	2023-04	Update the template
2024-03-B2	2024-03	Modify the content



灵星芯微 芯片经营

# Contents

<b>1、 General Description.....</b>	<b>3</b>
<b>2、 Block Diagram And Pin Description .....</b>	<b>4</b>
2.1、 Block Diagram .....	4
2.2、 Pin Configurations.....	4
2.3、 Pin Description.....	5
2.4、 Function Table.....	5
<b>3、 Electrical Parameter .....</b>	<b>6</b>
3.1、 Absolute Maximum Ratings.....	6
3.2、 Recommended Operating Conditions.....	6
3.3、 Electrical Characteristics .....	6
3.3.1、 DC Characteristics 1 .....	6
3.3.2、 DC Characteristics 2 .....	7
3.3.3、 AC Characteristics .....	7
<b>4、 Testing Circuit .....</b>	<b>8</b>
4.1、 AC Testing Circuit .....	8
4.2、 AC Testing Waveforms.....	8
4.3、 Measurement Points .....	8
4.4、 Test Data .....	8
<b>5、 Package Information .....</b>	<b>9</b>
5.1、 DIP14 .....	9
5.2、 SOP14 .....	10
5.3、 TSSOP14.....	11
<b>6、 Statements And Notes .....</b>	<b>12</b>
6.1、 The name and content of Hazardous substances or Elements in the product.....	12
6.2、 Notes .....	12



## 1、General Description

The CD4068 is an 8-input And Gate/Nand Gate. The outputs are fully buffered for highest noise immunity and pattern insensitivity to output impedance variations.

It operates over a recommended  $V_{DD}$  power supply range of 3V to 15V referenced to  $V_{SS}$  (usually ground). Unused inputs must be connected to  $V_{DD}$ ,  $V_{SS}$ , or another input.

### Features:

- Wide supply voltage range from 3V to 15V
- Fully static operation
- 5V, 10V, and 15V parametric ratings
- Standardized symmetrical output characteristics
- Inputs and outputs are protected against electrostatic effects
- Specified from  $-40^{\circ}\text{C}$  to  $+125^{\circ}\text{C}$
- Packaging information: DIP14/SOP14/TSSOP14

### Ordering Information:

#### Tube packing specifications:

Part number	Packaging form	Marking code	Tube quantity	Boxed tube quantity	Boxed quantity	Notes
CD4068BE(LX)	DIP14	CD4068BE	25 PCS/tube	40 tube/box	1000 PCS/box	Dimensions of plastic enclosure: 19.0mm×6.4mm Pin spacing: 2.54mm
CD4068BM(LX)	SOP14	CD4068BM	50 PCS/tube	200 tube/box	10000 PCS/box	Dimensions of plastic enclosure: 8.7mm×3.9mm Pin spacing: 1.27mm
CD4068PW(LX)	TSSOP14	CD4068	96 PCS/tube	200 tube/box	19200 PCS/box	Dimensions of plastic enclosure: 5.0mm×4.4mm Pin spacing: 0.65mm

#### Reel packing specifications:

Part number	Packaging form	Marking code	Reel quantity	Boxed reel quantity	Notes
CD4068BM(LX)	SOP14	CD4068BM	2500 PCS/reel	5000 PCS/box	Dimensions of plastic enclosure: 8.7mm×3.9mm Pin spacing: 1.27mm
CD4068PW(LX)	TSSOP14	CD4068	5000 PCS/reel	10000 PCS/box	Dimensions of plastic enclosure: 5.0mm×4.4mm Pin spacing: 0.65mm

Note: If the physical information is inconsistent with the ordering information, please refer to the actual product.



## 2、Block Diagram And Pin Description

### 2.1、Block Diagram

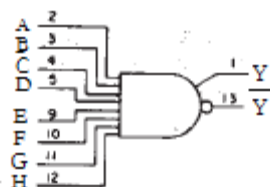

Figure 1. Functional diagram

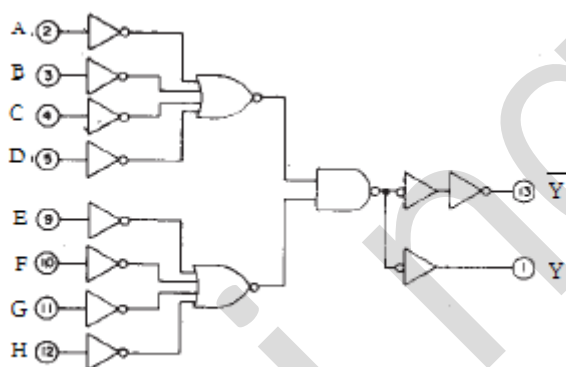
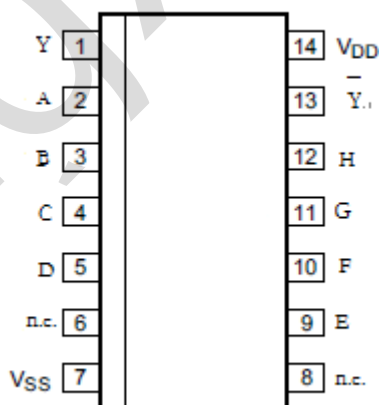

Figure 2. Logic diagram

### 2.2、Pin Configurations





### 2.3、Pin Description

Pin No.	Pin Name	Description
1	Y	data output
2	A	data input
3	B	data input
4	C	data input
5	D	data input
6	n.c.	not connected
7	V <sub>SS</sub>	ground (0V)
8	n.c.	not connected
9	E	data input
10	F	data input
11	G	data input
12	H	data input
13	$\bar{Y}$	complement output
14	V <sub>DD</sub>	supply voltage

### 2.4、Function Table

Input								Output	
A	B	C	D	E	F	G	H	Y	$\bar{Y}$
H	H	H	H	H	H	H	H	H	L
L	X	X	X	X	X	X	X	L	H
X	L	X	X	X	X	X	X	L	H
X	X	L	X	X	X	X	X	L	H
X	X	X	L	X	X	X	X	L	H
X	X	X	X	L	X	X	X	L	H
X	X	X	X	X	L	X	X	L	H
X	X	X	X	X	X	L	X	L	H
X	X	X	X	X	X	X	L	L	H

Note: H=HIGH voltage level; L=LOW voltage level; X=don't care.



### 3、Electrical Parameter

#### 3.1、Absolute Maximum Ratings

(Voltages are referenced to  $V_{SS}$  (ground=0V), unless otherwise specified.)

Parameter	Symbol	Conditions	Min.	Max.	Unit
supply voltage	$V_{DD}$	-	-0.5	+18	V
DC input current	$I_{IK}$	any one input	-	$\pm 10$	mA
input voltage	$V_I$	all inputs	-0.5	$V_{DD}+0.5$	V
storage temperature	$T_{stg}$	-	-65	+150	$^{\circ}C$
total power dissipation	$P_{tot}$	-	-	500	mW
device dissipation	$P$	per output transistor	-	100	mW
Soldering temperature	$T_L$	10s	DIP	245	$^{\circ}C$
			SOP/TSSOP	260	

#### 3.2、Recommended Operating Conditions

Parameter	Symbol	Conditions	Min.	Typ.	Max.	Unit
supply voltage	$V_{DD}$	-	3	-	15	V
ambient temperature	$T_{amb}$	in free air	-40	-	+125	$^{\circ}C$

#### 3.3、Electrical Characteristics

##### 3.3.1、DC Characteristics 1

( $T_{amb}=25^{\circ}C$ , voltages are referenced to  $V_{SS}$  (ground=0V), unless otherwise specified.)

Parameter	Symbol	Conditions (V)			$T_{amb}=25^{\circ}C$			Unit
		$V_O$	$V_{IN}$	$V_{DD}$	Min.	Typ.	Max.	
supply current	$I_{DD}$	-	0, 5	5	-	-	1	$\mu A$
		-	0, 10	10	-	-	1	$\mu A$
		-	0, 15	15	-	-	1	$\mu A$
LOW-level output current	$I_{OL}$	0.4	0, 5	5	0.51	1	-	mA
		0.5	0, 10	10	1.3	2.6	-	mA
		1.5	0, 15	15	3.4	6.8	-	mA
HIGH-level output current	$I_{OH}$	4.6	0, 5	5	-0.51	-1	-	mA
		2.5	0, 5	5	-1.6	-3.2	-	mA
		9.5	0, 10	10	-1.3	-2.6	-	mA
		13.5	0, 15	15	-3.4	-6.8	-	mA
LOW-level output voltage	$V_{OL}$	-	0, 5	5	-	0	0.05	V
		-	0, 10	10	-	0	0.05	V
		-	0, 15	15	-	0	0.05	V
HIGH-level output voltage	$V_{OH}$	-	0, 5	5	4.95	5	-	V
		-	0, 10	10	9.95	10	-	V
		-	0, 15	15	14.95	15	-	V
LOW-level input voltage	$V_{IL}$	0.5, 4.5	-	5	-	-	1.5	V
		1, 9	-	10	-	-	3	V
		1.5, 13.5	-	15	-	-	4	V
HIGH-level input voltage	$V_{IH}$	0.5, 4.5	-	5	3.5	-	-	V
		1, 9	-	10	7	-	-	V



		1.5, 13.5	-	15	11	-	-	V
input leakage current	$I_I$	-	0, 15	15	-	-	$\pm 1$	$\mu\text{A}$

### 3.3.2、DC Characteristics 2

( $T_{\text{amb}}=-40^{\circ}\text{C}$  to  $+125^{\circ}\text{C}$ , voltages are referenced to  $V_{\text{SS}}$  (ground=0V), unless otherwise specified.)

Parameter	Symbol	Conditions (V)			$T_{\text{amb}}=-40^{\circ}\text{C}$		$T_{\text{amb}}=+85^{\circ}\text{C}$		$T_{\text{amb}}=+125^{\circ}\text{C}$		Unit
		$V_O$	$V_{\text{IN}}$	$V_{\text{DD}}$	Min.	Max.	Min.	Max.	Min.	Max.	
supply current	$I_{\text{DD}}$	-	0, 5	5	-	1	-	7.5	-	7.5	$\mu\text{A}$
		-	0, 10	10	-	1	-	15	-	15	$\mu\text{A}$
		-	0, 15	15	-	1	-	30	-	30	$\mu\text{A}$
LOW-level output current	$I_{\text{OL}}$	0.4	0, 5	5	0.61	-	0.42	-	0.36	-	mA
		0.5	0, 10	10	1.5	-	1.1	-	0.9	-	mA
		1.5	0, 15	15	4	-	2.8	-	2.4	-	mA
HIGH-level output current	$I_{\text{OH}}$	4.6	0, 5	5	-0.61	-	-0.42	-	-0.36	-	mA
		2.5	0, 5	5	-1.8	-	-1.3	-	-1.15	-	mA
		9.5	0, 10	10	-1.5	-	-1.1	-	-0.9	-	mA
		13.5	0, 15	15	-4	-	-2.8	-	-2.4	-	mA
LOW-level output voltage	$V_{\text{OL}}$	-	0, 5	5	-	0.05	-	0.05	-	0.05	V
		-	0, 10	10	-	0.05	-	0.05	-	0.05	V
		-	0, 15	15	-	0.05	-	0.05	-	0.05	V
HIGH-level output voltage	$V_{\text{OH}}$	-	0, 5	5	4.95	-	4.95	-	4.95	-	V
		-	0, 10	10	9.95	-	9.95	-	9.95	-	V
		-	0, 15	15	14.95	-	14.95	-	14.95	-	V
LOW-level input voltage	$V_{\text{IL}}$	0.5, 4.5	-	5	-	1.5	-	1.5	-	1.5	V
		1, 9	-	10	-	3	-	3	-	3	V
		1.5, 13.5	-	15	-	4	-	4	-	4	V
HIGH-level input voltage	$V_{\text{IH}}$	0.5, 4.5	-	5	3.5	-	3.5	-	3.5	-	V
		1, 9	-	10	7	-	7	-	7	-	V
		1.5, 13.5	-	15	11	-	11	-	11	-	V
input leakage current	$I_I$	-	0, 15	15	-	$\pm 1$	-	$\pm 1$	-	$\pm 1$	$\mu\text{A}$

### 3.3.3、AC Characteristics

( $T_{\text{amb}}=25^{\circ}\text{C}$ ,  $V_{\text{SS}}=0\text{V}$ ,  $t_r, t_f=20\text{ns}$ ,  $C_L=50\text{pF}$ ,  $R_L=200\text{k}\Omega$ , unless otherwise specified.)

Parameter	Symbol	Conditions	Min.	Typ.	Max.	Unit	
propagation delay time	$t_{\text{PHL}}, t_{\text{PLH}}$	see Figure 4	$V_{\text{DD}}=5\text{V}$	-	150	300	ns
		$V_{\text{DD}}=10\text{V}$	-	75	150	ns	
		$V_{\text{DD}}=15\text{V}$	-	55	110	ns	
transition time	$t_{\text{THL}}, t_{\text{TLH}}$	see Figure 4	$V_{\text{DD}}=5\text{V}$	-	100	200	ns
		$V_{\text{DD}}=10\text{V}$	-	50	100	ns	
		$V_{\text{DD}}=15\text{V}$	-	40	80	ns	
input capacitance	$C_I$	any input	-	5	7.5	pF	



## 4、Testing Circuit

### 4.1、AC Testing Circuit

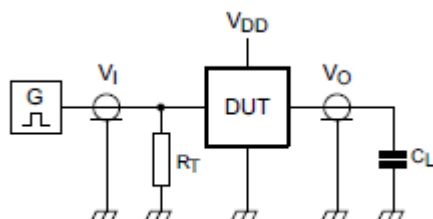

Figure 3. Test circuit for switching times

Definitions for test circuit:

DUT=Device Under Test.

$C_L$ =Load capacitance including jig and probe capacitance.

$R_T$ =Termination resistance should be equal to the output impedance  $Z_o$  of the pulse generator.

### 4.2、AC Testing Waveforms

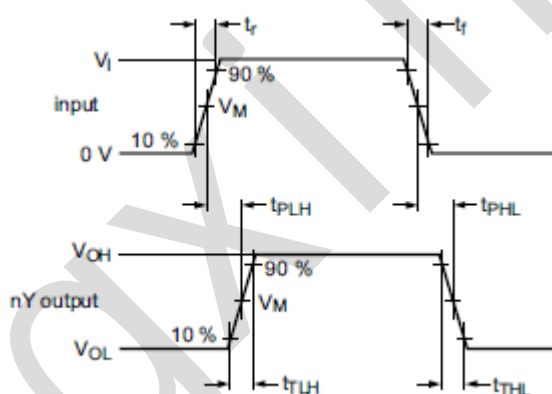

Figure 4. Input to output propagation delay and output transition times

### 4.3、Measurement Points

Supply voltage	Input	Output
$V_{DD}$	$V_M$	$V_M$
5V to 15V	$0.5 \times V_{DD}$	$0.5 \times V_{DD}$

### 4.4、Test Data

Supply voltage	Input		Load
$V_{DD}$	$V_I$	$t_r, t_f$	$C_L$
5V to 15V	$V_{SS}$ or $V_{DD}$	$\leq 20\text{ns}$	50pF





## 5、Package Information

### 5.1、DIP14

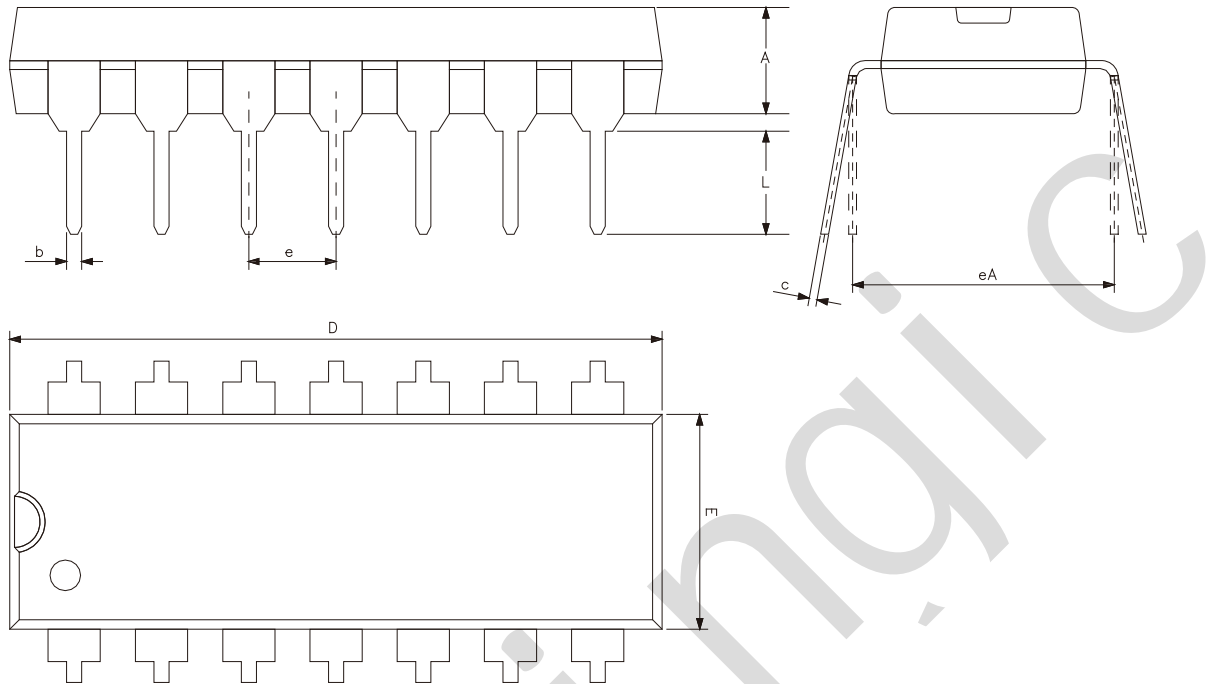

Symbol	Dimensions (mm)	
	Min.	Max.
A	3.05	3.60
b	0.33	0.56
c	0.20	0.36
D	18.80	19.40
E	6.20	6.60
e	2.54	
eA	7.62	10.90
L	2.92	-



灵星芯微 芯片封装

## 5.2、SOP14

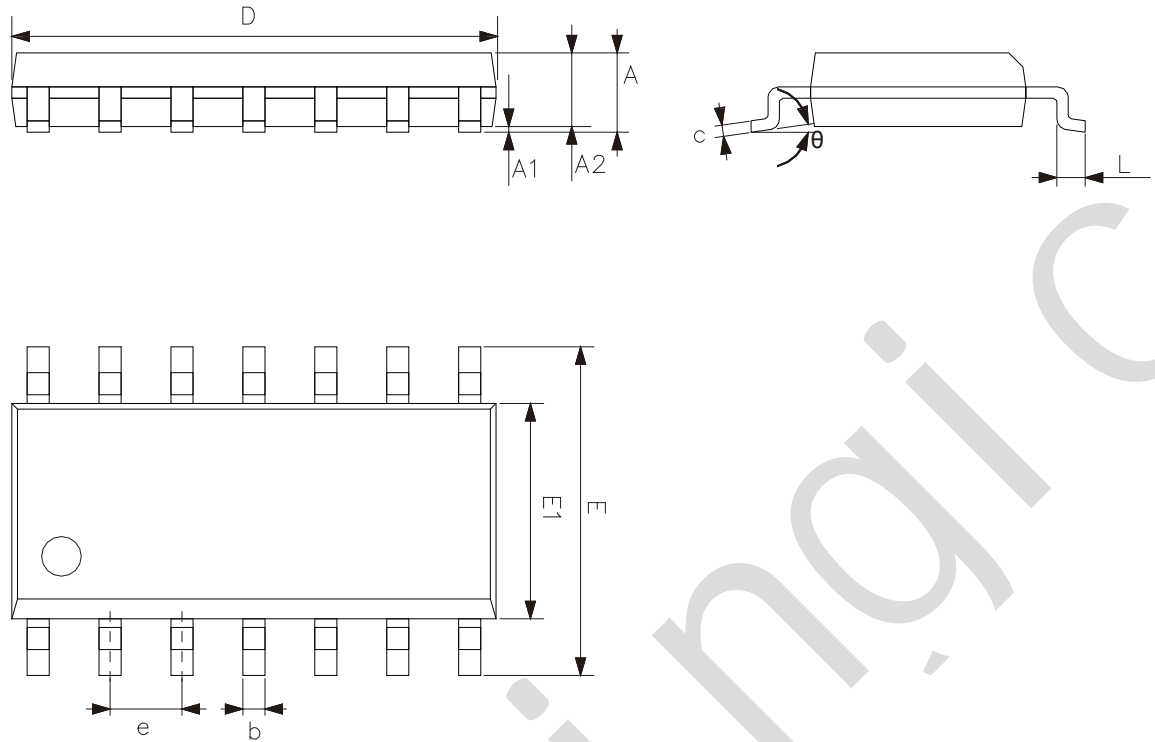

Symbol	Dimensions (mm)	
	Min.	Max.
A	1.50	1.75
A1	0.05	0.25
A2	1.30	-
b	0.33	0.50
c	0.19	0.25
D	8.43	8.76
E	5.80	6.25
E1	3.75	4.00
e	1.27	
L	0.40	0.89
$\theta$	0°	8°



### 5.3、TSSOP14

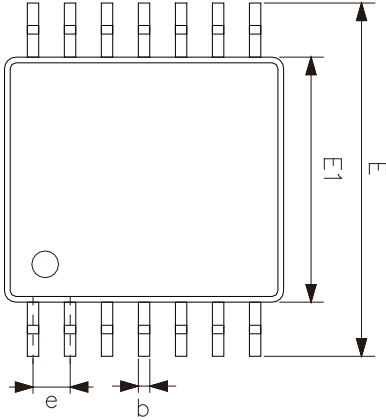
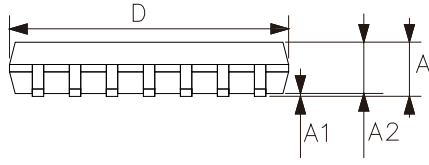

Symbol	Dimensions (mm)	
	Min.	Max.
A	-	1.20
A1	0.05	0.15
A2	0.80	1.05
b	0.19	0.30
c	0.09	0.20
D	4.90	5.10
E1	4.30	4.50
E	6.20	6.60
e	0.65	
L	0.45	0.75
L1	1.00	
$\theta$	0°	8°



## 6、 Statements And Notes

### 6.1、 The name and content of Hazardous substances or Elements in the product

Part name	Hazardous substances or Elements									
	Lead and lead compounds	Mercury and mercury compounds	Cadmium and cadmium compounds	Hexavalent chromium compounds	Polybrominated biphenyls	Polybrominated biphenyl ethers	Dibutyl phthalate	Butylbenzyl phthalate	Di-2-ethylhexyl phthalate	Diisobutyl phthalate
Lead frame	○	○	○	○	○	○	○	○	○	○
Plastic resin	○	○	○	○	○	○	○	○	○	○
Chip	○	○	○	○	○	○	○	○	○	○
The lead	○	○	○	○	○	○	○	○	○	○
Plastic sheet installed	○	○	○	○	○	○	○	○	○	○
explanation	○: Indicates that the content of hazardous substances or elements in the detection limit of the following the SJ/T11363-2006 standard. ×: Indicates that the content of hazardous substances or elements exceeding the SJ/T11363-2006 Standard limit requirements.									

### 6.2、 Notes

We Recommend you to read this chapter carefully before using this product.

The information in this chapter is provided for reference only and Lingxing disclaims any express or implied warranties, including but not limited to applicability, special application or non-infringement of third party rights.

This product is not suitable for critical equipment such as life-saving, life-sustaining or safety equipment. It is also not suitable for applications that may result in personal injury, death, or serious property or environmental damage due to product malfunction or failure. Lingxing will not be liable for any damages incurred by the customers at their own risk for such applications.

The customer is responsible for conducting all necessary tests Lingxing's application to avoid failure in the application or the application of the customer's third party users. Lingxing does not accept any liability.

The Company reserves the right to change or improve the information published in this chapter at any time. The information in this chapter are subject to change without notice. We recommend the customer to consult our sales staff before purchasing.

Please obtain related materials form Lingxing's regular channels and we are not responsible for its content if it is provided by sources other than our company.

In case of any conflict between the Chinese and English version, the version is subject to the Chinese one.

## X-ON Electronics

Largest Supplier of Electrical and Electronic Components

*Click to view similar products for [Logic Gates](#) category:*

*Click to view products by [lingxingic](#) manufacturer:*

Other Similar products are found below :

[NL17SG32DFT2G](#) [CD4068BE](#) [NL17SG86DFT2G](#) [NLX1G11AMUTCG](#) [NLX1G97MUTCG](#) [74LS38](#) [74LVC1G08Z-7](#) [CD4025BE](#)  
[NLV17SZ00DFT2G](#) [NLV17SZ126DFT2G](#) [NLV27WZ17DFT2G](#) [NLV74HC02ADR2G](#) [74HC32S14-13](#) [74LS133](#) [74LVC1G32Z-7](#)  
[74LVC1G86Z-7](#) [NLV74HC14ADR2G](#) [NLV74HC20ADR2G](#) [NLVVHC1G09DFT1G](#) [NLX2G86MUTCG](#) [74LVC2G32RA3-7](#)  
[74LVC2G00HD4-7](#) [NL17SG02P5T5G](#) [74LVC2G86HK3-7](#) [NLVVHC1G14DFT2G](#) [NLX1G99DMUTWG](#) [NLVVHC1G00DFT2G](#)  
[NLV7SZ57DFT2G](#) [NLV74VHC04DTR2G](#) [NLV27WZ00USG](#) [NLU1G86CMUTCG](#) [NLU1G08CMUTCG](#) [NL17SZ32P5T5G](#)  
[NL17SZ00P5T5G](#) [NL17SH02P5T5G](#) [74AUP2G00RA3-7](#) [NLVVHC1GT00DFT2G](#) [NLV74HC02ADTR2G](#) [NLX1G332CMUTCG](#)  
[NLVHCT132ADTR2G](#) [NL17SG86P5T5G](#) [NL17SZ05P5T5G](#) [NLV74VHC00DTR2G](#) [NLVVHC1G02DFT1G](#) [NLV74HC86ADR2G](#)  
[74LVC2G32HK3-7](#) [74LVC2G86RA3-7](#) [NL17SZ38DBVT1G](#) [NLV18SZ00DFT2G](#) [NLVVHC1G07DFT1G](#)