



CD4556 (LX)

Dual 1-of-4 decoder/demultiplexer

Product Specification

Specification Revision History:

Version	Date	Description
2023-04-A1	2023-04	New



Contents

1、 General Description.....	3
2、 Block Diagram And Pin Description	4
2.1、 Block Diagram	4
2.2、 Pin Configurations.....	4
2.3、 Pin Description	5
2.4、 Function Table.....	5
3、 Electrical Parameter	5
3.1、 Absolute Maximum Ratings.....	5
3.2、 Recommended Operating Conditions	6
3.3、 Electrical Characteristics	6
3.3.1、 DC Characteristics 1	6
3.3.2、 DC Characteristics 2	7
3.3.3、 AC Characteristics 1	8
3.3.4、 AC Characteristics 2	8
4、 Testing Circuit	9
4.1、 AC Testing Circuit	9
4.2、 Test Data	9
4.3、 AC Testing Waveforms.....	10
4.4、 Measurement Points	10
5、 Package Information	11
5.1、 DIP16	11
5.2、 SOP16	12
5.3、 TSSOP16.....	13
6、 Statements And Notes	14
6.1、 The name and content of Hazardous substances or Elements in the product	14
6.2、 Notes	14



1、General Description

The CD4556 is a dual 1-of-4 decoder/demultiplexer.

Features:

- Supply voltage range: 3V to 15V
- Temperature range: -40°C to +125°C
- Packaging information: DIP/SOP/TSSOP16

Ordering Information:

Tube packing specifications:

Part number	Packaging form	Marking code	Tube quantity	Boxed tube quantity	Boxed quantity	Notes
CD4556BE(LX)	DIP16	CD4556BE	25 PCS/tube	40 tube/box	1000 PCS/box	Dimensions of plastic enclosure: 19.0mm×6.4mm Pin spacing: 2.54mm
CD4556BM(LX)	SOP16	CD4556BM	50 PCS/tube	200 tube/box	10000 PCS/box	Dimensions of plastic enclosure: 10.0mm×3.9mm Pin spacing: 1.27mm
CD4556PW(LX)	TSSOP16	CD4556	96 PCS/tube	200 tube/box	19200 PCS/box	Dimensions of plastic enclosure: 5.0mm×4.4mm Pin spacing: 0.65mm

Reel packing specifications:

Part number	Packaging form	Marking code	Reel quantity	Boxed reel quantity	Notes
CD4556BM(LX)	SOP16	CD4556BM	2500PCS/reel	5000PCS/box	Dimensions of plastic enclosure: 10.0mm×3.9mm Pin spacing: 1.27mm
CD4556PW(LX)	TSSOP16	CD4556	5000PCS/reel	10000PCS/box	Dimensions of plastic enclosure: 5.0mm×4.4mm Pin spacing: 0.65mm



2、Block Diagram And Pin Description

2.1、Block Diagram

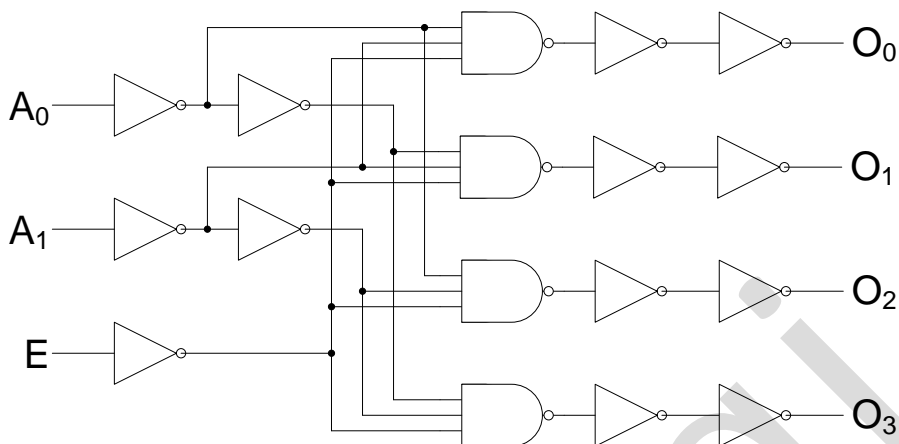
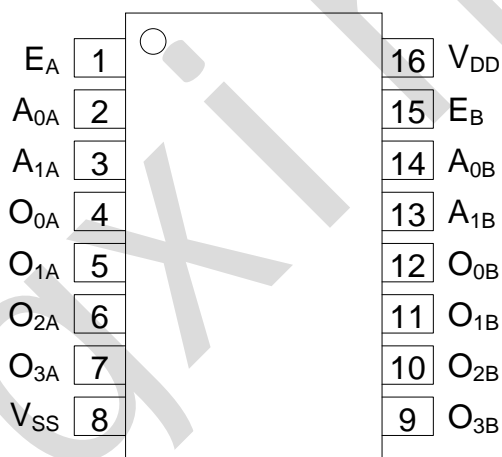

Figure 1. Functional diagram

2.2、Pin Configurations





2.3、Pin Description

Pin No.	Pin Name	Description
1	E _A	enable input
2	A _{0A}	address input
3	A _{1A}	address input
4	O _{0A}	output(active LOW)
5	O _{1A}	output(active LOW)
6	O _{2A}	output(active LOW)
7	O _{3A}	output(active LOW)
8	V _{SS}	ground supply voltage
9	O _{3B}	output(active LOW)
10	O _{2B}	output(active LOW)
11	O _{1B}	output(active LOW)
12	O _{0B}	output(active LOW)
13	A _{1B}	address input
14	A _{0B}	address input
15	E _B	enable input
16	V _{DD}	supply voltage

2.4、Function Table

Inputs			Outputs			
E	A ₀	A ₁	O ₀	O ₁	O ₂	O ₃
L	L	L	L	H	H	H
L	H	L	H	L	H	H
L	L	H	H	H	L	H
L	H	H	H	H	H	L
H	X	X	H	H	H	H

Note:

H=HIGH state (the more positive voltage);

L=LOW voltage level(the less positive voltage);

X=state is immaterial.

3、Electrical Parameter

3.1、Absolute Maximum Ratings

(Voltages are referenced to V_{SS} (ground=0V), unless otherwise specified.)

Parameter	Symbol	Conditions	Min.	Max.	Unit
supply voltage	V _{DD}	-	-0.5	+18	V
input voltage	V _I	all inputs	-0.5	V _{DD} +0.5	V
DC input current	I _{IK}	any one input	-	±10	mA
storage temperature	T _{stg}	-	-65	+150	°C
soldering temperature	T _L	10s	DIP	245	°C
			SOP/TSSOP	260	



3.2、Recommended Operating Conditions

Parameter	Symbol	Conditions	Min.	Typ.	Max.	Unit
supply voltage	V_{DD}	-	3	-	15	V
ambient temperature	T_{amb}	in free air	-40	-	+125	°C

3.3、Electrical Characteristics

3.3.1、DC Characteristics 1

($T_{amb}=-40^{\circ}\text{C}$ to $+85^{\circ}\text{C}$, voltages are referenced to V_{SS} (ground=0V), unless otherwise specified.)

Parameter	Symbol	V_{DD}	Conditions	Min.	Typ.	Max.	Unit
HIGH-level input voltage	V_{IH}	5V	-	3.5	-	-	V
		10V	-	7	-	-	V
		15V	-	11	-	-	V
LOW-level input voltage	V_{IL}	5V	-	-	-	1.5	V
		10V	-	-	-	3	V
		15V	-	-	-	4	V
HIGH-level output voltage	V_{OH}	5V	$ I_O <1\mu\text{A}$	4.95	-	-	V
		10V	$ I_O <1\mu\text{A}$	9.95	-	-	V
		15V	$ I_O <1\mu\text{A}$	14.95	-	-	V
LOW-level output voltage	V_{OL}	5V	$ I_O <1\mu\text{A}$	-	-	0.05	V
		10V	$ I_O <1\mu\text{A}$	-	-	0.05	V
		15V	$ I_O <1\mu\text{A}$	-	-	0.05	V
HIGH-level output current	I_{OH}	5V	$V_O=4.6\text{V}$	-	-	-0.34	mA
		5V	$V_O=2.5\text{V}$	-	-	-1.3	mA
		10V	$V_O=9.5\text{V}$	-	-	-0.55	mA
		15V	$V_O=13.5\text{V}$	-	-	-1.65	mA
LOW-level output current	I_{OL}	5V	$V_O=0.4\text{V}$	0.34	-	-	mA
		10V	$V_O=0.5\text{V}$	0.46	-	-	mA
		15V	$V_O=1.5\text{V}$	1.4	-	-	mA
input leakage current	I_I	15V	$V_I=15\text{V}$ or GND	-	-	± 2	μA
supply current	I_{DD}	5V	$V_I=5\text{V}$ or GND; $I_O=0\text{A}$	-	-	7.5	μA
		10V	$V_I=10\text{V}$ or GND; $I_O=0\text{A}$	-	-	15	μA
		15V	$V_I=15\text{V}$ or GND; $I_O=0\text{A}$	-	-	30	μA



3.3.2、DC Characteristics 2

($T_{amb} = -40^{\circ}\text{C}$ to $+125^{\circ}\text{C}$, voltages are referenced to V_{SS} (ground=0V), unless otherwise specified.)

Parameter	Symbol	V_{DD}	Conditions	Min.	Typ.	Max.	Unit
HIGH-level input voltage	V_{IH}	5V	-	3.5	-	-	V
		10V	-	7	-	-	V
		15V	-	11	-	-	V
LOW-level input voltage	V_{IL}	5V	-	-	-	1.5	V
		10V	-	-	-	3	V
		15V	-	-	-	4	V
HIGH-level output voltage	V_{OH}	5V	$ I_O < 1\mu\text{A}$	4.95	-	-	V
		10V	$ I_O < 1\mu\text{A}$	9.95	-	-	V
		15V	$ I_O < 1\mu\text{A}$	14.95	-	-	V
LOW-level output voltage	V_{OL}	5V	$ I_O < 1\mu\text{A}$	-	-	0.05	V
		10V	$ I_O < 1\mu\text{A}$	-	-	0.05	V
		15V	$ I_O < 1\mu\text{A}$	-	-	0.05	V
HIGH-level output current	I_{OH}	5V	$V_O = 4.6\text{V}$	-	-	-0.3	mA
		5V	$V_O = 2.5\text{V}$	-	-	-1.15	mA
		10V	$V_O = 9.5\text{V}$	-	-	-0.45	mA
		15V	$V_O = 13.5\text{V}$	-	-	-1.4	mA
LOW-level output current	I_{OL}	5V	$V_O = 0.4\text{V}$	0.29	-	-	mA
		10V	$V_O = 0.5\text{V}$	0.38	-	-	mA
		15V	$V_O = 1.5\text{V}$	1.2	-	-	mA
input leakage current	I_I	15V	$V_I = 15\text{V}$ or GND	-	-	± 4	μA
supply current	I_{DD}	5V	$V_I = 5\text{V}$ or GND; $I_O = 0\text{A}$	-	-	7.5	μA
		10V	$V_I = 10\text{V}$ or GND; $I_O = 0\text{A}$	-	-	15	μA
		15V	$V_I = 15\text{V}$ or GND; $I_O = 0\text{A}$	-	-	30	μA



3.3.3、AC Characteristics 1

($T_{amb}=-40^{\circ}\text{C}$ to $+85^{\circ}\text{C}$, $V_{SS}=0\text{V}$, unless otherwise specified.)

Parameter	Symbol	V_{DD}	Conditions	Min.	Typ.	Max.	Unit
HIGH to LOW propagation delay time	t_{PHL}	5V	An to Qn	-	130	255	ns
		10V	$C_L=50\text{pF}$	-	50	100	ns
		15V	see Figure 4	-	35	65	ns
		5V	En to Qn	-	120	240	ns
		10V	$C_L=50\text{pF}$	-	45	90	ns
		15V	see Figure 4	-	30	60	ns
LOW to HIGH propagation delay time	t_{PLH}	5V	An to Qn	-	105	210	ns
		10V	$C_L=50\text{pF}$	-	40	85	ns
		15V	see Figure 4	-	30	60	ns
		5V	En to Qn	-	105	205	ns
		10V	$C_L=50\text{pF}$	-	40	80	ns
		15V	see Figure 4	-	30	60	ns
transition time	t_{THL}, t_{TLH}	5V	see Figure 4	-	60	120	ns
		10V		-	30	60	ns
		15V		-	20	40	ns

3.3.4、AC Characteristics 2

($T_{amb}=-40^{\circ}\text{C}$ to $+125^{\circ}\text{C}$, $V_{SS}=0\text{V}$, unless otherwise specified.)

Parameter	Symbol	V_{DD}	Conditions	Min.	Typ.	Max.	Unit
HIGH to LOW propagation delay time	t_{PHL}	5V	An to Qn	-	-	305	ns
		10V	$C_L=50\text{pF}$	-	-	120	ns
		15V	see Figure 4	-	-	78	ns
		5V	En to Qn	-	-	280	ns
		10V	$C_L=50\text{pF}$	-	-	108	ns
		15V	see Figure 4	-	-	72	ns
LOW to HIGH propagation delay time	t_{PLH}	5V	An to Qn	-	-	42	ns
		10V	$C_L=50\text{pF}$	-	-	102	ns
		15V	see Figure 4	-	-	72	ns
		5V	En to Qn	-	-	245	ns
		10V	$C_L=50\text{pF}$	-	-	96	ns
		15V	see Figure 4	-	-	72	ns
transition time	t_{THL}, t_{TLH}	5V	see Figure 4	-	-	144	ns
		10V		-	-	72	ns
		15V		-	-	48	ns



4、Testing Circuit

4.1、AC Testing Circuit

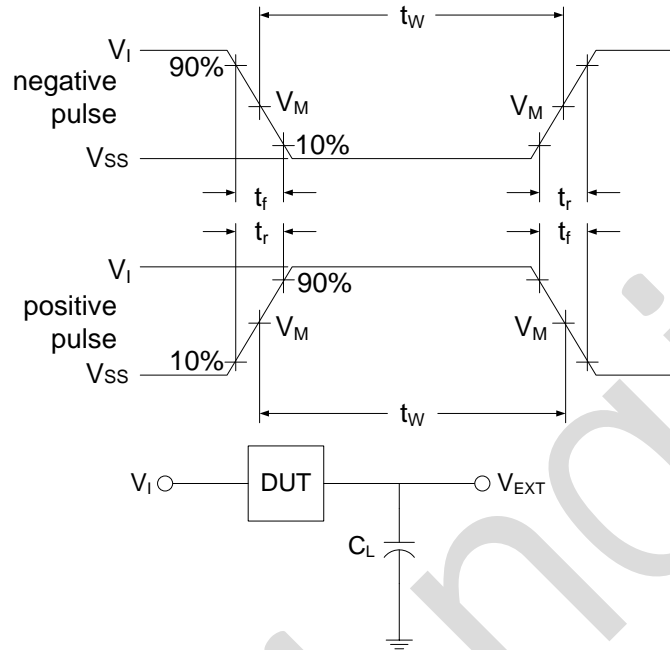

Figure 3. Load circuit

C_L includes probe and jig capacitance.

4.2、Test Data

Supply voltage	Input		Load	V_{EXT}		
	V_I	$t_r = t_f$		C_L	t_{PLH}/t_{PHL}	t_{PLZ}/t_{PZL}
V_{DD} 5V to 15V	V_{DD}	$\leq 20\text{ns}$	50pF	Open	V_{DD}	V_{SS}



4.3、AC Testing Waveforms

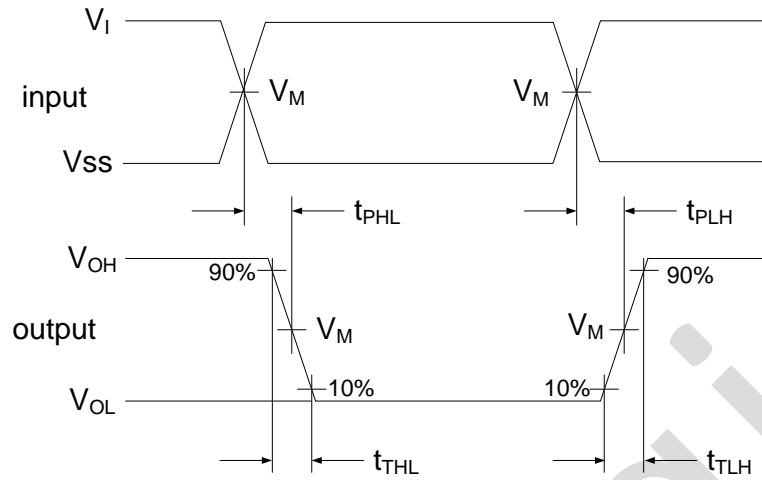

Figure 4. Propagation delay, output transition time

4.4、Measurement Points

Supply voltage	Input	Output		
		V_M	V_X	V_Y
V_{DD} 5V to 15V	$0.5 \times V_{DD}$	$0.5 \times V_{DD}$	$0.1 \times V_{DD}$	$0.9 \times V_{DD}$



5、Package Information

5.1、DIP16

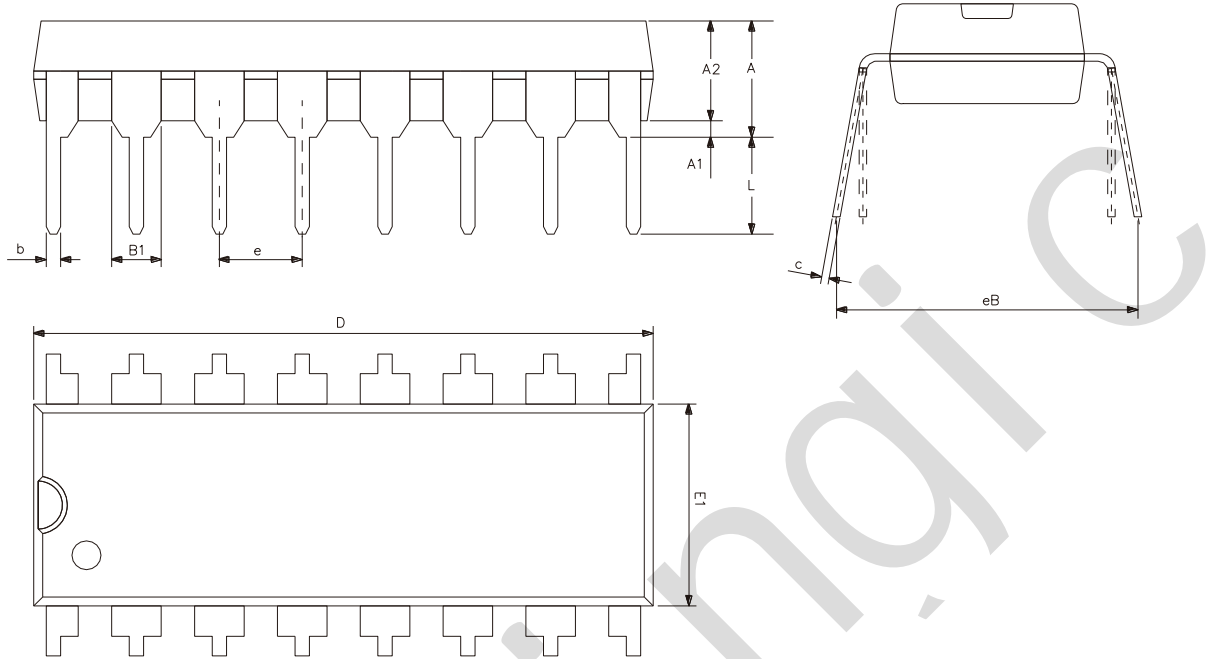

Symbol	Dimensions (mm)	
	Min.	Max.
A2	3.20	3.60
A1	0.51	-
A	3.60	5.33
L	3.00	3.60
b	0.36	0.56
B1	1.52	
D	18.80	19.94
E1	6.20	6.60
e	2.54	
c	0.20	0.36
eB	7.62	9.30



5.2、SOP16

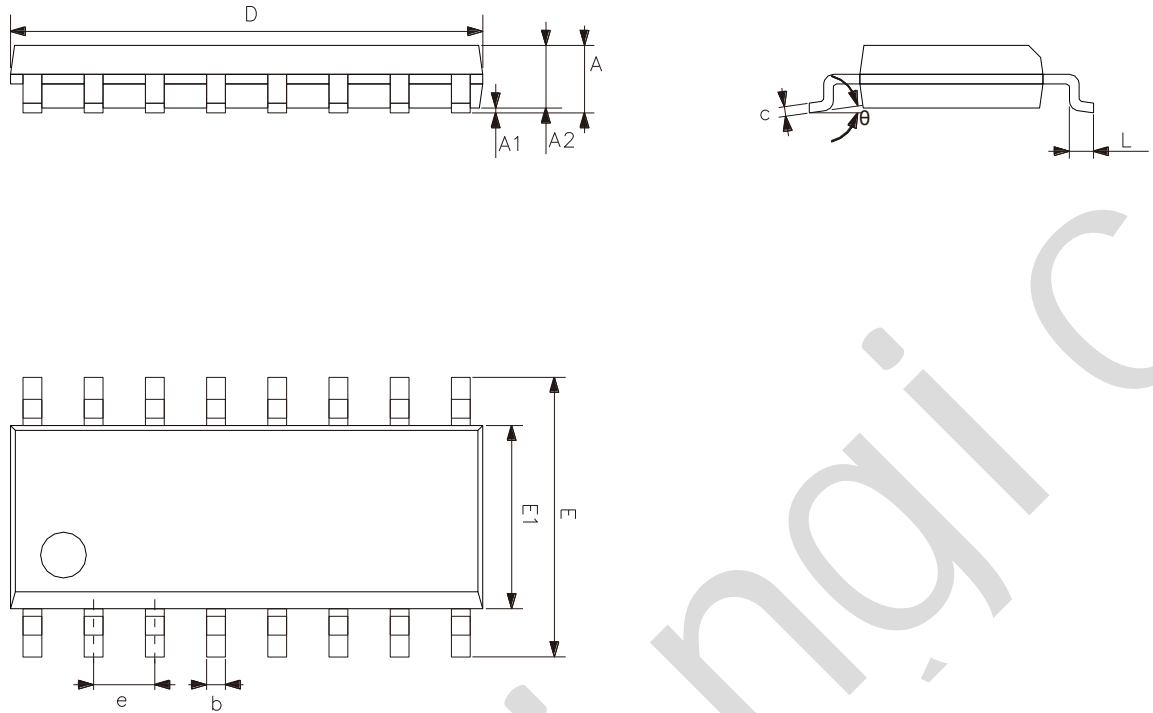

Symbol	Dimensions (mm)	
	Min.	Max.
A	1.35	1.80
A1	0.10	0.25
A2	1.25	1.55
b	0.33	0.51
c	0.19	0.25
D	9.50	10.10
E	5.80	6.30
E1	3.70	4.10
e	1.27	
L	0.35	0.89
θ	0°	8°



5.3、TSSOP16

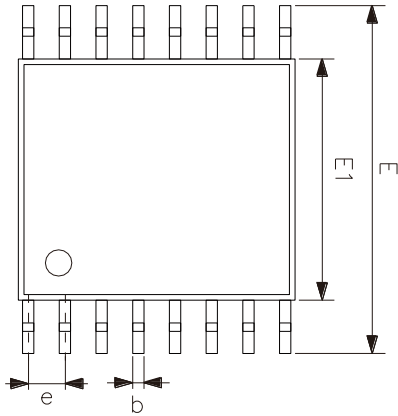
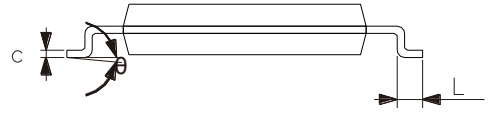
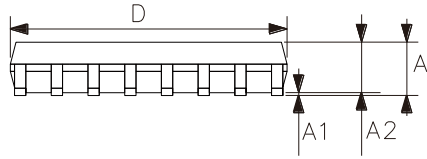

Symbol	Dimensions (mm)	
	Min.	Max.
A	-	1.20
A1	0.05	0.15
A2	0.80	1.05
b	0.19	0.30
c	0.09	0.20
D	4.90	5.10
E1	4.30	4.50
E	6.20	6.60
e	0.65	
L	0.45	0.75
θ	0°	8°



6、 Statements And Notes

6.1、 The name and content of Hazardous substances or Elements in the product

Part name	Hazardous substances or Elements									
	Lead and lead compounds	Mercury and mercury compounds	Cadmium and cadmium compounds	Hexavalent chromium compounds	Polybrominated biphenyls	Polybrominated biphenyl ethers	Dibutyl phthalate	Butylbenzyl phthalate	Di-2-ethylhexyl phthalate	Diisobutyl phthalate
Lead frame	○	○	○	○	○	○	○	○	○	○
Plastic resin	○	○	○	○	○	○	○	○	○	○
Chip	○	○	○	○	○	○	○	○	○	○
The lead	○	○	○	○	○	○	○	○	○	○
Plastic sheet installed	○	○	○	○	○	○	○	○	○	○
explanation	○: Indicates that the content of hazardous substances or elements in the detection limit of the following the SJ/T11363-2006 standard. ×: Indicates that the content of hazardous substances or elements exceeding the SJ/T11363-2006 Standard limit requirements.									

6.2、 Notes

We Recommend you to read this chapter carefully before using this product.

The information in this chapter is provided for reference only and Lingxing disclaims any express or implied warranties, including but not limited to applicability, special application or non-infringement of third party rights.

This product is not suitable for critical equipment such as life-saving, life-sustaining or safety equipment. It is also not suitable for applications that may result in personal injury, death, or serious property or environmental damage due to product malfunction or failure. Lingxing will not be liable for any damages incurred by the customers at their own risk for such applications.

The customer is responsible for conducting all necessary tests Lingxing's application to avoid failure in the application or the application of the customer's third party users. Lingxing does not accept any liability. The Company reserves the right to change or improve the information published in this chapter at any time. The information in this chapter are subject to change without notice. We recommend the customer to consult our sales staff before purchasing.

Please obtain related materials form Lingxing's regular channels and we are not responsible for its content if it is provided by sources other than our company.

In case of any conflict between the Chinese and English version, the version is subject to the Chinese one.

X-ON Electronics

Largest Supplier of Electrical and Electronic Components

Click to view similar products for [Encoders, Decoders, Multiplexers & Demultiplexers](#) category:

Click to view products by [lingxingic](#) manufacturer:

Other Similar products are found below :

[MC74HC163ADTG](#) [74HC253N](#) [NLV74VHC1G01DFT1G](#) [NLVHCT4851ADTR2G](#) [NLV14028BDR2G](#) [COMX-CAR-210](#) [SN74LS148N](#)
[PI3B3251LE](#) [PI3B3251QE](#) [NLV74HC4851AMNTWG](#) [MC74LVX257DG](#) [M74HCT4851ADWR2G](#) [NL7SZ19DBVT1G](#) [PI5C3253LEX](#)
[MC74HC251ADTG](#) [MC74ACT138NG](#) [NB3L8533DTR2G](#) [NLV74AC157DR2G](#) [74HC138DT](#) [74HC153DT](#) [74HC238DT](#) [74HC151DT](#)
[ADS131M02IRUKR](#) [CBMG709ATS16](#) [74HC238N](#) [HT74HC154ARWZ](#) [RS2G139XS16-G](#) [74HCT251D](#) [74HC138T](#) [U74HC138G-S16-R](#)
[AIP74HCT138SA.TB](#) [XD74C922](#) [RS1G157XC6](#) [74HC151M/TR](#) [AiP74HC237TA16.TB](#) [AIP74HC138TA16.TB](#) [74HC138DRG](#)
[AiP74LVC138TA16.TB](#) [CD4511BDRG](#) [AiP74LVC157TA16.TB](#) [SN74HC42N\(LX\)](#) [SN74LS157N\(LX\)](#) [SN74LS42N](#) [TC4053BFT\(EL,N\)](#)
[74VHC4052AFT\(BE\)](#) [TC74VHC138FK\(EL,K\)](#) [TC74HC151AF\(EL,F\)](#) [SN74HC145DR\(LX\)](#) [SN74HC139DR\(LX\)](#) [CD4028BM\(LX\)](#)