



灵星芯微 芯片经营

深圳市灵星芯微电子科技有限公司

Shenzhen Lingxing Microelectronics Technology Co., Ltd.

Tab: 835-12-B4

Number: SN7406-AX-LJ-A083EN

SN7406 (LX) Hex Inverter with Open-drain outputs

Product Specification

Specification Revision History:

Version	Date	Description
2023-07-A1	2023-07	New



Contents

1、 General Description.....	3
2、 Block Diagram And Pin Description	5
2.1、 Block Diagram	5
2.2、 Pin Configurations	5
2.3、 Pin Description.....	6
2.4、 Function Table	6
3、 Electrical Parameter	6
3.1、 Absolute Maximum Ratings.....	6
3.2、 Recommended Operating Conditions	7
3.3、 Electrical Characteristics.....	7
3.3.1、 DC Characteristics 1	7
3.3.2、 DC Characteristics 2	8
3.3.3、 AC Characteristics 1	9
3.3.4、 AC Characteristics 2	9
4、 Testing Circuit	10
4.1、 AC Testing Circuit.....	10
4.2、 AC Testing Waveforms.....	10
4.3、 Measurement Points	11
4.4、 Test Data	11
5、 Package Information	12
5.1、 DIP14.....	12
5.2、 SOP14.....	13
6、 Statements And Notes	14
6.1、 The name and content of Hazardous substances or Elements in the product	14
6.2、 Notes.....	14



1、General Description

The SN7406 contains six inverters. The outputs of the SN7406 are open-drain. The open-drain outputs require pull-up resistors to perform correctly.

Features:

- Specified from -40°C to +125°C
- Packaging information: DIP14/SOP14/TSSOP14

Ordering Information:

Tube packing specifications:

Type number	Packaging form	Marking code	Tube quantity	Boxed tube quantity	Boxed quantity	Notes
SN7406N(LX)	DIP14	SN7406N	25 PCS/tube	40 tube/box	1000 PCS/box	Dimensions of plastic enclosure: 19.0mm×6.4mm Pin spacing: 2.54mm
SN7406DR(LX)	SOP14	7406	50 PCS/tube	200 tube/box	10000 PCS/box	Dimensions of plastic enclosure: 8.7mm×3.9mm Pin spacing: 1.27mm



Reel packing specifications:

Type number	Packaging form	Marking code	Reel quantity	Boxed reel quantity	Notes
SN7406DR(LX)	SOP14	7406	2500 PCS/reel	5000 PCS/box	Dimensions of plastic enclosure: 8.7mm×3.9mm Pin spacing: 1.27mm

Note: If the physical information is inconsistent with the ordering information, please refer to the actual product.

2、Block Diagram And Pin Description

2.1、Block Diagram

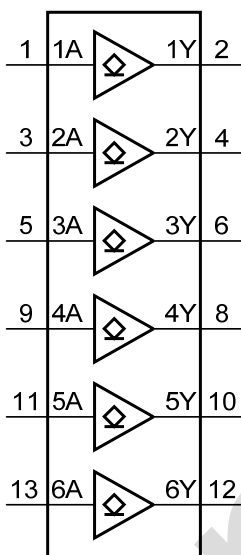

Figure 1. Logic symbol

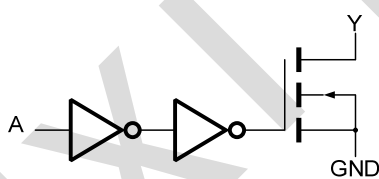
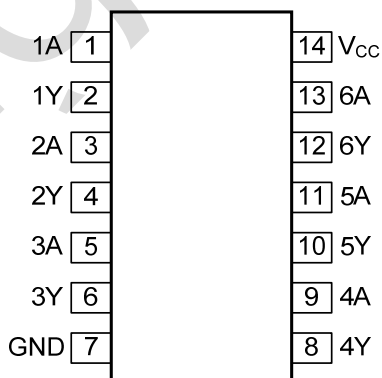

Figure 2. Logic diagram (one gate)

2.2、Pin Configurations





2.3、Pin Description

Pin No.	Pin Name	Description
1	1A	data input
2	1Y	data output
3	2A	data input
4	2Y	data output
5	3A	data input
6	3Y	data output
7	GND	ground (0V)
8	4Y	data output
9	4A	data input
10	5Y	data output
11	5A	data input
12	6Y	data output
13	6A	data input
14	V _{CC}	supply voltage

2.4、Function Table

Input	Output
nA	nY
L	Z
H	L

Note: H=HIGH voltage level; L=LOW voltage level; Z=high-impedance OFF-state.

3、Electrical Parameter

3.1、Absolute Maximum Ratings

(Voltages are referenced to GND (ground=0V), unless otherwise specified.)

Parameter	Symbol	Conditions	Min.	Max.	Unit
supply voltage	V _{CC}	-	-0.5	+7.0	V
output voltage	V _O	-	-0.5	+7.0	V
input clamping current	I _{IK}	V _I <-0.5V or V _I >V _{CC} +0.5V	-	±20	mA
output clamping current	I _{OK}	V _O <-0.5V	-	-20	mA
output current	I _O	-0.5V<V _O	-	-25	mA
supply current	I _{CC}	-	-	+50	mA
ground current	I _{GND}	-	-50	-	mA
storage temperature	T _{stg}	-	-65	+150	°C
total power dissipation	P _{tot}	-	-	500	mW
soldering temperature	T _L	10s	DIP	245	°C
			SOP	260	



3.2、Recommended Operating Conditions

Parameter	Symbol	Conditions	Min.	Typ.	Max.	Unit
supply voltage	V_{CC}	-	2.0	5.0	6.0	V
input voltage	V_I	-	0	-	V_{CC}	V
output voltage	V_O	-	0	-	V_{CC}	V
ambient temperature	T_{amb}	-	-40	-	+125	°C

3.3、Electrical Characteristics

3.3.1、DC Characteristics 1

(T_{amb} = -40°C to +85°C, voltages are referenced to GND (ground=0V), unless otherwise specified.)

Parameter	Symbol	Conditions	Min.	Typ.	Max.	Unit	
HIGH-level input voltage	V_{IH}	$V_{CC}=2.0V$	1.5	1.2	-	V	
		$V_{CC}=4.5V$	3.15	2.4	-	V	
		$V_{CC}=6.0V$	4.2	3.2	-	V	
LOW-level input voltage	V_{IL}	$V_{CC}=2.0V$	-	0.8	0.5	V	
		$V_{CC}=4.5V$	-	2.1	1.35	V	
		$V_{CC}=6.0V$	-	2.8	1.8	V	
LOW-level output voltage	V_{OL}	$V_I=V_{IH}$ or V_{IL}	$I_O=20\mu A$; $V_{CC}=2.0V$	-	0	0.1	V
			$I_O=20\mu A$; $V_{CC}=4.5V$	-	0	0.1	V
			$I_O=20\mu A$; $V_{CC}=6.0V$	-	0	0.1	V
			$I_O=4.0mA$; $V_{CC}=4.5V$	-	0.15	0.33	V
			$I_O=5.2mA$; $V_{CC}=6.0V$	-	0.16	0.33	V
input leakage current	I_I	$V_I=V_{CC}$ or GND; $V_{CC}=6.0V$	-	-	±2	uA	
OFF-state output current	I_{OZ}	per input pin; $V_I=V_{IL}$; $V_O=V_{CC}$ or GND; other inputs at V_{CC} or GND; $V_{CC}=6.0V$; $I_O=0A$	-	-	±2	uA	
supply current	I_{CC}	$V_I=V_{CC}$ or GND; $I_O=0A$; $V_{CC}=6.0V$	-	-	2	uA	



3.3.2、DC Characteristics 2

($T_{amb}=-40^{\circ}\text{C}$ to $+125^{\circ}\text{C}$, voltages are referenced to GND (ground=0V), unless otherwise specified.)

Parameter	Symbol	Conditions	Min.	Typ.	Max.	Unit	
HIGH-level input voltage	V_{IH}	$V_{CC}=2.0\text{V}$	1.5	-	-	V	
		$V_{CC}=4.5\text{V}$	3.15	-	-	V	
		$V_{CC}=6.0\text{V}$	4.2	-	-	V	
LOW-level input voltage	V_{IL}	$V_{CC}=2.0\text{V}$	-	-	0.5	V	
		$V_{CC}=4.5\text{V}$	-	-	1.35	V	
		$V_{CC}=6.0\text{V}$	-	-	1.8	V	
LOW-level output voltage	V_{OL}	$V_I=V_{IH}$ or V_{IL}	$I_O=20\mu\text{A}; V_{CC}=2.0\text{V}$	-	-	0.1	V
			$I_O=20\mu\text{A}; V_{CC}=4.5\text{V}$	-	-	0.1	V
			$I_O=20\mu\text{A}; V_{CC}=6.0\text{V}$	-	-	0.1	V
			$I_O=4.0\text{mA}; V_{CC}=4.5\text{V}$	-	-	0.4	V
			$I_O=5.2\text{mA}; V_{CC}=6.0\text{V}$	-	-	0.4	V
input leakage current	I_I	$V_I=V_{CC}$ or GND; $V_{CC}=6.0\text{V}$	-	-	± 4	μA	
OFF-state output current	I_{OZ}	per input pin; $V_I=V_{IL}$; $V_O=V_{CC}$ or GND; other inputs at V_{CC} or GND; $V_{CC}=6.0\text{V}$; $I_O=0\text{A}$	-	-	± 4	μA	
supply current	I_{CC}	$V_I=V_{CC}$ or GND; $I_O=0\text{A}$; $V_{CC}=6.0\text{V}$	-	-	4	μA	



3.3.3、AC Characteristics 1

($T_{amb}=-40^{\circ}\text{C}$ to $+85^{\circ}\text{C}$, $\text{GND}=0\text{V}$, $C_L=50\text{pF}$, unless otherwise specified.)

Parameter	Symbol	Conditions	Min.	Typ.	Max.	Unit	
nA to nY propagation delay	t_{pd}	see Figure 4 ^[1]	$V_{CC}=2.0\text{V}$	-	28	120	ns
			$V_{CC}=4.5\text{V}$	-	10	24	ns
			$V_{CC}=5.0\text{V}; C_L=15\text{pF}$	-	8	-	ns
			$V_{CC}=6.0\text{V}$	-	8	20	ns
transition time	t_t	see Figure 4 ^[2]	$V_{CC}=2.0\text{V}$	-	19	95	ns
			$V_{CC}=4.5\text{V}$	-	7	19	ns
			$V_{CC}=6.0\text{V}$	-	6	16	ns

Note:

[1] t_{pd} is the same as t_{PLZ} and t_{PZL} .

[2] t_t is the same as t_{THL} .

3.3.4、AC Characteristics 2

($T_{amb}=-40^{\circ}\text{C}$ to $+125^{\circ}\text{C}$, $\text{GND}=0\text{V}$, $C_L=50\text{pF}$, unless otherwise specified.)

Parameter	Symbol	Conditions	Min.	Typ.	Max.	Unit	
nA to nY propagation delay	t_{pd}	see Figure 4 ^[1]	$V_{CC}=2.0\text{V}$	-	-	145	ns
			$V_{CC}=4.5\text{V}$	-	-	29	ns
			$V_{CC}=6.0\text{V}$	-	-	25	ns
transition time	t_t	see Figure 4 ^[2]	$V_{CC}=2.0\text{V}$	-	-	110	ns
			$V_{CC}=4.5\text{V}$	-	-	22	ns
			$V_{CC}=6.0\text{V}$	-	-	19	ns

Note:

[1] t_{pd} is the same as t_{PLZ} and t_{PZL} .

[2] t_t is the same as t_{THL} .

4、Testing Circuit

4.1、AC Testing Circuit

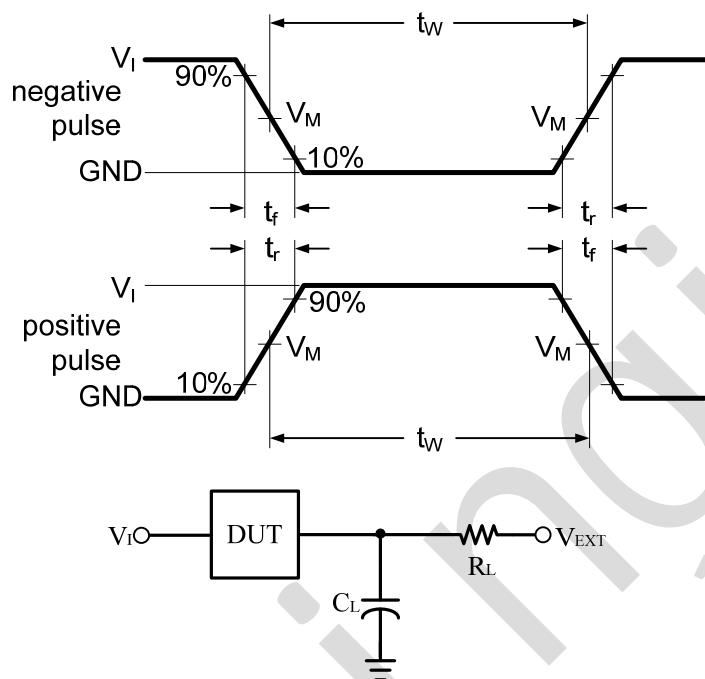

Figure 3. Test circuit for measuring switching times

C_L includes probe and jig capacitance.

4.2、AC Testing Waveforms

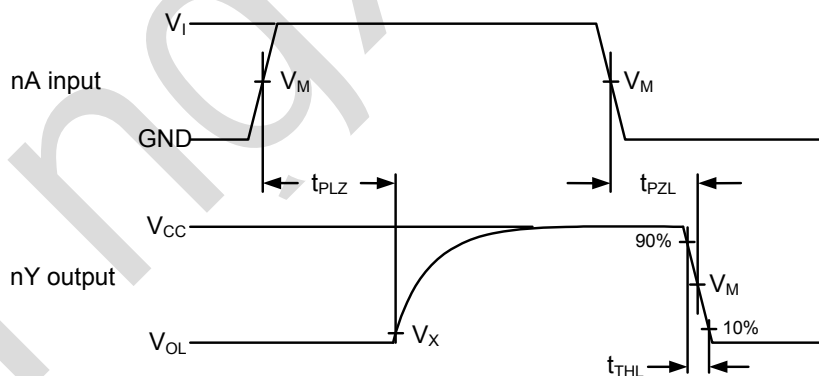

Figure 4. The input nA to output nY propagation delays and output transition times



4.3、Measurement Points

Input	Output	
V_M	V_M	V_X
$0.5 \times V_{CC}$	$0.5 \times V_{CC}$	$0.1 \times V_{CC}$

4.4、Test Data

Input		Load		S1 position
V_I	t_r, t_f	C_L	R_L	t_{pZL}, t_{pLZ}
V_{CC}	6ns	15pF, 50pF	1k Ω	V_{CC}



5、Package Information

5.1、DIP14

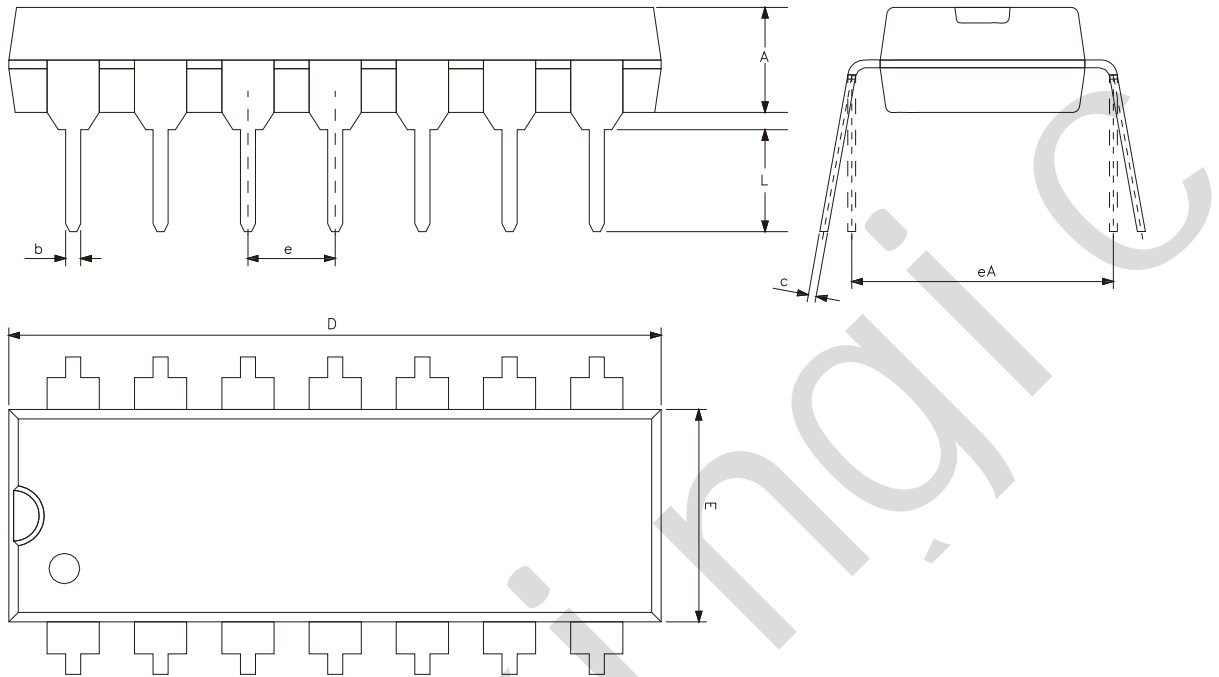

Symbol	Dimensions (mm)	
	Min.	Max.
A	3.05	3.60
b	0.33	0.56
c	0.20	0.36
D	18.80	19.40
E	6.20	6.60
e	2.54	
eA	7.62	10.90
L	2.92	-



5.2、SOP14

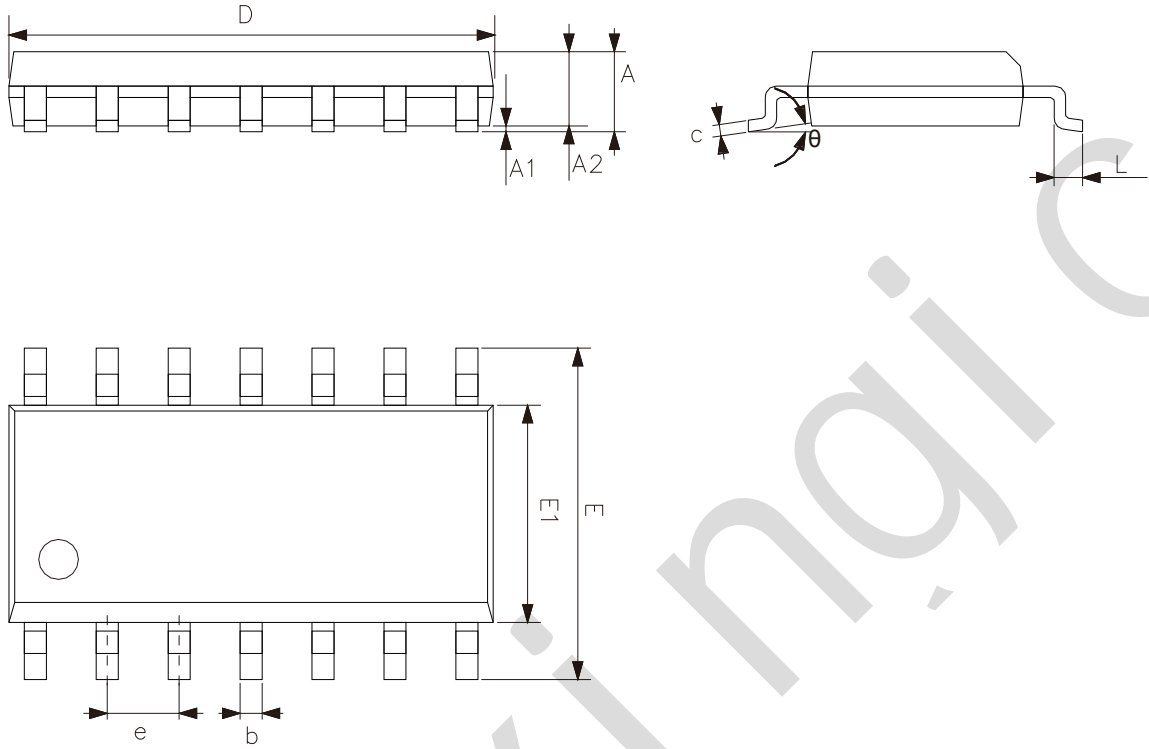

Symbol	Dimensions (mm)	
	Min.	Max.
A	1.50	1.75
A1	0.05	0.25
A2	1.30	-
b	0.33	0.50
c	0.19	0.25
D	8.43	8.76
E	5.80	6.25
E1	3.75	4.00
e	1.27	
L	0.40	0.89
θ	0°	8°



6、 Statements And Notes

6.1、 The name and content of Hazardous substances or Elements in the product

Part name	Hazardous substances or Elements									
	Lead and lead compounds	Mercury and mercury compounds	Cadmium and cadmium compounds	Hexavalent chromium compounds	Polybrominated biphenyls	Polybrominated biphenyl ethers	Dibutyl phthalate	Butylbenzyl phthalate	Di-2-ethylhexyl phthalate	Diisobutyl phthalate
Lead frame	○	○	○	○	○	○	○	○	○	○
Plastic resin	○	○	○	○	○	○	○	○	○	○
Chip	○	○	○	○	○	○	○	○	○	○
The lead	○	○	○	○	○	○	○	○	○	○
Plastic sheet installed	○	○	○	○	○	○	○	○	○	○
explanation	<p>○: Indicates that the content of hazardous substances or elements in the detection limit of the following the SJ/T11363-2006 standard.</p> <p>×: Indicates that the content of hazardous substances or elements exceeding the SJ/T11363-2006 Standard limit requirements.</p>									

6.2、 Notes

We recommend you to read this chapter carefully before using this product.

The information in this chapter is provided for reference only and Lingxing disclaims any express or implied warranties, including but not limited to applicability, special application or non-infringement of third party rights.

This product is not suitable for critical equipment such as life-saving, life-sustaining or safety equipment. It is also not suitable for applications that may result in personal injury, death, or serious property or environmental damage due to product malfunction or failure. Lingxing will not be liable for any damages incurred by the customers at their own risk for such applications.

The customer is responsible for conducting all necessary tests Lingxing's application to avoid failure in the application or the application of the customer's third party users. Lingxing does not accept any liability.

The Company reserves the right to change or improve the information published in this chapter at any time. The information in this chapter are subject to change without notice. We recommend the customer to consult our sales staff before purchasing.

Please obtain related materials from Lingxing's regular channels and we are not responsible for its content if it is provided by sources other than our company.

In case of any conflict between the Chinese and English version, the version is subject to the Chinese one.

X-ON Electronics

Largest Supplier of Electrical and Electronic Components

Click to view similar products for [Inverters](#) category:

Click to view products by [lingxingic](#) manufacturer:

Other Similar products are found below :

[E5-652Z](#) [NLX2G04BMX1TCG](#) [CD4009UBE](#) [TC4584BFN](#) [NL17SG14AMUTCG](#) [NLU2GU04BMX1TCG](#) [NLV17SZ14DFT2G](#)
[NLV74HC04ADTR2G](#) [NLU1G04AMUTCG](#) [NLX2G04CMUTCG](#) [NLX2G04AMUTCG](#) [NLV27WZ04DFT1G](#) [NLU1G04CMUTCG](#)
[NL17SZU04P5T5G](#) [74LVC06ADTR2G](#) [74LVC04ADR2G](#) [NLV37WZ04USG](#) [NLX3G14FMUTCG](#) [NL17SZ04P5T5G](#) [NL17SG14P5T5G](#)
[NLV27WZU04DFT2G](#) [NLV17SG14DFT2G](#) [NLVHC1G04DFT2G](#) [MC14069UBD](#) [NLU3G14CMX1TCG](#) [NLX2G14BMX1TCG](#)
[NLX2GU04AMX1TCG](#) [74HCT04DT](#) [74HCT14DT](#) [74LCX14FT\(AJ\)](#) [GN14D](#) [GN4069](#) [74HC04DM/TR](#) [HG74HC04M/TR](#) [CD4007BE](#)
[74HC14DN](#) [74HC14DM/TR](#) [74HC125M/TR](#) [HG74HC04MT/TR](#) [74HC14DMT/TR](#) [74HC04DN](#) [HT74HC04ARZ](#) [HT40106ARZ](#) [74HC14-](#)
[HXY](#) [IW4069UBN](#) [RS1GT04XC5](#) [RS6G14XP](#) [RS2G17XH6](#) [RS2G14XC6](#) [RS2G04XC6](#)