



SN74HC/HCT05 (LX)

Hex Inverter with Open-drain outputs

Product Specification

Specification Revision History:

Version	Date	Description
2022-11-A2	2022-11	Modify ambient temperature to $-40^{\circ}\text{C} \sim +125^{\circ}\text{C}$
2022-12-A3	2022-12	Modify Ordering Information



1、General Description

The SN74HC/HCT05 contains six inverters. The outputs of the SN74HC/HCT05 are open-drain and can be connected to other open-drain outputs to implement active-LOW wired-OR or active-HIGH wired-AND functions. The open-drain outputs require pull-up resistors to perform correctly.

Features:

- Input levels:
 - For SN74HC05: CMOS level
 - For SN74HCT05: TTL level
- Latch-up performance exceeds 100 mA per JESD 78 Class II level A
- Specified from -40°C to +125°C
- Packaging information: DIP14/SOP14/TSSOP14

Ordering Information:

Tube packing specifications:

Part number	Packaging form	Marking code	Tube quantity	Boxed tube quantity	Boxed quantity	Notes
SN74HC05N(LX)	DIP14	SN74HC05N	25 PCS/tube	40 tube/box	1000 PCS/box	Dimensions of plastic enclosure: 19.0mm×6.4mm Pin spacing: 2.54mm
SN74HCT05N(LX)	DIP14	SN74HCT05N	25 PCS/tube	40 tube/box	1000 PCS/box	Dimensions of plastic enclosure: 19.0mm×6.4mm Pin spacing: 2.54mm



Reel packing specifications:

Part number	Packaging form	Markingcode	Reel quantity	Boxed reel quantity	Notes
SN74HC05DR (LX)	SOP14	SN74HC05	4000 PCS/reel	8000 PCS/box	Dimensions of plastic enclosure: 8.7mm×3.9mm Pin spacing: 1.27mm
SN74HCT05DR (LX)	SOP14	SN74HCT05	4000 PCS/reel	8000 PCS/box	Dimensions of plastic enclosure: 8.7mm×3.9mm Pin spacing: 1.27mm
SN74HC05PWR (LX)	TSSOP14	SN74HC05	5000 PCS/reel	10000 PCS/box	Dimensions of plastic enclosure: 5.0mm×4.4mm Pin spacing: 0.65mm
SN74HCT05PWR (LX)	TSSOP14	SN74HCT05	5000 PCS/reel	10000 PCS/box	Dimensions of plastic enclosure: 5.0mm×4.4mm Pin spacing: 0.65mm

Note: If the physical information is inconsistent with the ordering information, please refer to the actual product.



2、Block Diagram And Pin Description

2.1、Block Diagram

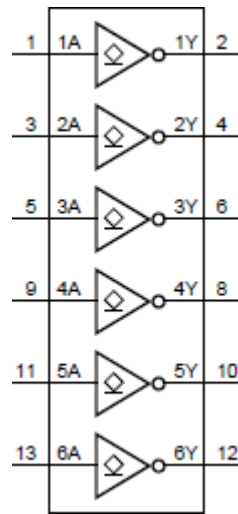

Figure 1. Logic symbol

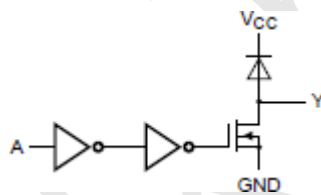
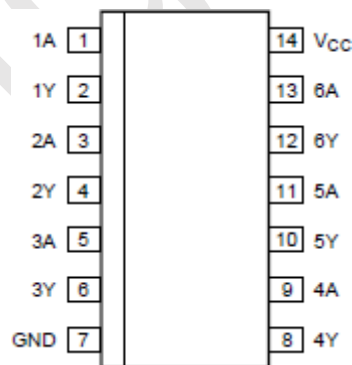

Figure 2. Logic diagram (one gate)

2.2、Pin Configurations





2.3、Pin Description

Pin No.	Pin Name	Description
1	1A	data input
2	1Y	data output
3	2A	data input
4	2Y	data output
5	3A	data input
6	3Y	data output
7	GND	ground (0V)
8	4Y	data output
9	4A	data input
10	5Y	data output
11	5A	data input
12	6Y	data output
13	6A	data input
14	V _{CC}	supply voltage

2.4、Function Table

Input	Output
nA	nY
L	Z
H	L

Note: H=HIGH voltage level; L=LOW voltage level; Z=high-impedance OFF-state.

3、Electrical Parameter

3.1、Absolute Maximum Ratings

(Voltages are referenced to GND (ground=0V), unless otherwise specified.)

Parameter	Symbol	Conditions	Min.	Max.	Unit
supply voltage	V _{CC}	-	-0.5	+7.0	V
output voltage	V _O	-	-0.5	+7.0	V
input clamping current	I _{IK}	V _I <-0.5V or V _I >V _{CC} +0.5V	-	±20	mA
output clamping current	I _{OK}	V _O <-0.5V	-	-20	mA
output current	I _O	-0.5V<V _O	-	-25	mA
supply current	I _{CC}	-	-	+50	mA
ground current	I _{GND}	-	-50	-	mA
storage temperature	T _{stg}	-	-65	+150	°C
total power dissipation	P _{tot}	-	-	500	mW
soldering temperature	T _L	10s	DIP	245	°C
			SOP	250	

Note:

[1] For DIP14 packages: above 70°C the value of P_{tot} derates linearly with 12mW/K.

[2] For SOP14 packages: above 70°C the value of P_{tot} derates linearly with 8mW/K.

[3] For (T)SSOP14 packages: above 60°C the value of P_{tot} derates linearly with 5.5mW/K.



3.2、Recommended Operating Conditions

Parameter	Symbol	Conditions	Min.	Typ.	Max.	Unit
SN74HC05						
supply voltage	V_{CC}	-	2.0	5.0	6.0	V
input voltage	V_I	-	0	-	V_{CC}	V
output voltage	V_O	-	0	-	V_{CC}	V
input transition rise and fall rate	$\Delta t/\Delta V$	$V_{CC}=2.0V$	-	-	625	ns/V
		$V_{CC}=4.5V$	-	1.67	139	ns/V
		$V_{CC}=6.0V$	-	-	83	ns/V
ambient temperature	T_{amb}	-	-40	-	+105	°C
SN74HCT05						
supply voltage	V_{CC}	-	4.5	5.0	5.5	V
input voltage	V_I	-	0	-	V_{CC}	V
output voltage	V_O	-	0	-	V_{CC}	V
input transition rise and fall rate	$\Delta t/\Delta V$	$V_{CC}=2.0V$	-	-	-	ns/V
		$V_{CC}=4.5V$	-	1.67	139	ns/V
		$V_{CC}=6.0V$	-	-	-	ns/V
ambient temperature	T_{amb}	-	-40	-	+105	°C

3.3、Electrical Characteristics

3.3.1、DC Characteristics 1

($T_{amb}=25^{\circ}C$, voltages are referenced to GND (ground=0V), unless otherwise specified.)

Parameter	Symbol	Conditions	Min.	Typ.	Max.	Unit	
SN74HC05							
HIGH-level input voltage	V_{IH}	$V_{CC}=2.0V$	1.5	1.2	-	V	
		$V_{CC}=4.5V$	3.15	2.4	-	V	
		$V_{CC}=6.0V$	4.2	3.2	-	V	
LOW-level input voltage	V_{IL}	$V_{CC}=2.0V$	-	0.8	0.5	V	
		$V_{CC}=4.5V$	-	2.1	1.35	V	
		$V_{CC}=6.0V$	-	2.8	1.8	V	
LOW-level output voltage	V_{OL}	$V_I=V_{IH}$ or V_{IL}	$I_O=20\mu A; V_{CC}=2.0V$	-	0	0.1	V
			$I_O=20\mu A; V_{CC}=4.5V$	-	0	0.1	V
			$I_O=20\mu A; V_{CC}=6.0V$	-	0	0.1	V
			$I_O=4.0mA; V_{CC}=4.5V$	-	0.15	0.26	V
			$I_O=5.2mA; V_{CC}=6.0V$	-	0.16	0.26	V
input leakage current	I_I	$V_I=V_{CC}$ or GND; $V_{CC}=6.0V$	-	-	± 0.1	μA	
OFF-state output current	I_{OZ}	per input pin; $V_I=V_{IL}; V_O=V_{CC}$ or GND; other inputs at V_{CC} or GND; $V_{CC}=6.0V; I_O=0A$	-	-	± 0.5	μA	
supply current	I_{CC}	$V_I=V_{CC}$ or GND; $I_O=0A; V_{CC}=6.0V$	-	-	2	μA	
input capacitance	C_I	-	-	3.5	-	pF	
SN74HCT05							



HIGH-level input voltage	V_{IH}	$V_{CC}=4.5V$ to $5.5V$	2.0	1.6	-	V	
LOW-level input voltage	V_{IL}	$V_{CC}=4.5V$ to $5.5V$	-	1.2	0.8	V	
LOW-level output voltage	V_{OL}	$V_I=V_{IH}$ or V_{IL} ; $V_{CC}=4.5V$	$I_O=20\mu A$	-	0	0.1	V
			$I_O=4.0mA$	-	0.15	0.26	V
input leakage current	I_I	$V_I=V_{CC}$ or GND; $V_{CC}=5.5V$	-	-	± 0.1	μA	
OFF-state output current	I_{OZ}	per input pin; $V_I=V_{IL}$; $V_O=V_{CC}$ or GND; other inputs at V_{CC} or GND; $V_{CC}=5.5V$; $I_O=0A$	-	-	± 0.5	μA	
supply current	I_{CC}	$V_I=V_{CC}$ or GND; $I_O=0A$; $V_{CC}=5.5V$	-	-	2	μA	
additional supply current	ΔI_{CC}	per input pin; $V_I=V_{CC}-2.1V$; other inputs at V_{CC} or GND; $I_O=0A$; $V_{CC}=4.5V$ to $5.5V$	-	100	360	μA	
input capacitance	C_I	-	-	3.5	-	pF	

3.3.2 、 DC Characteristics 2

($T_{amb}=-40^{\circ}C$ to $+85^{\circ}C$, voltages are referenced to GND (ground=0V), unless otherwise specified.)

Parameter	Symbol	Conditions	Min.	Typ.	Max.	Unit	
SN74HC05							
HIGH-level input voltage	V_{IH}	$V_{CC}=2.0V$	1.5	-	-	V	
		$V_{CC}=4.5V$	3.15	-	-	V	
		$V_{CC}=6.0V$	4.2	-	-	V	
LOW-level input voltage	V_{IL}	$V_{CC}=2.0V$	-	-	0.5	V	
		$V_{CC}=4.5V$	-	-	1.35	V	
		$V_{CC}=6.0V$	-	-	1.8	V	
LOW-level output voltage	V_{OL}	$V_I=V_{IH}$ or V_{IL}	$I_O=20\mu A$; $V_{CC}=2.0V$	-	-	0.1	V
			$I_O=20\mu A$; $V_{CC}=4.5V$	-	-	0.1	V
			$I_O=20\mu A$; $V_{CC}=6.0V$	-	-	0.1	V
			$I_O=4.0mA$; $V_{CC}=4.5V$	-	-	0.33	V
			$I_O=5.2mA$; $V_{CC}=6.0V$	-	-	0.33	V
input leakage current	I_I	$V_I=V_{CC}$ or GND; $V_{CC}=6.0V$	-	-	± 1.0	μA	
OFF-state output current	I_{OZ}	per input pin; $V_I=V_{IL}$; $V_O=V_{CC}$ or GND; other inputs at V_{CC} or GND; $V_{CC}=6.0V$; $I_O=0A$	-	-	± 5.0	μA	
supply current	I_{CC}	$V_I=V_{CC}$ or GND; $I_O=0A$; $V_{CC}=6.0V$	-	-	20	μA	
SN74HCT05							
HIGH-level input voltage	V_{IH}	$V_{CC}=4.5V$ to $5.5V$	2.0	-	-	V	
LOW-level input voltage	V_{IL}	$V_{CC}=4.5V$ to $5.5V$	-	-	0.8	V	
LOW-level	V_{OL}	$V_I=V_{IH}$ or V_{IL} ; $I_O=20\mu A$	-	-	0.1	V	



output voltage		$V_{CC}=4.5V$	$I_O=4.0mA$	-	-	0.33	V
input leakage current	I_I	$V_I=V_{CC}$ or GND; $V_{CC}=5.5V$		-	-	± 1.0	μA
OFF-state output current	I_{OZ}	per input pin; $V_I=V_{IL}$; $V_O=V_{CC}$ or GND; other inputs at V_{CC} or GND; $V_{CC}=5.5V$; $I_O=0A$		-	-	± 5.0	μA
supply current	I_{CC}	$V_I=V_{CC}$ or GND; $I_O=0A$; $V_{CC}=5.5V$		-	-	20	μA
additional supply current	ΔI_{CC}	per input pin; $V_I=V_{CC}-2.1V$; other inputs at V_{CC} or GND; $I_O=0A$; $V_{CC}=4.5V$ to $5.5V$		-	-	450	μA

3.3.3 DC Characteristics 3

($T_{amb}=-40^{\circ}C$ to $+105^{\circ}C$, voltages are referenced to GND (ground=0V), unless otherwise specified.)

Parameter	Symbol	Conditions	Min.	Typ.	Max.	Unit	
SN74HC05							
HIGH-level input voltage	V_{IH}	$V_{CC}=2.0V$	1.5	-	-	V	
		$V_{CC}=4.5V$	3.15	-	-	V	
		$V_{CC}=6.0V$	4.2	-	-	V	
LOW-level input voltage	V_{IL}	$V_{CC}=2.0V$	-	-	0.5	V	
		$V_{CC}=4.5V$	-	-	1.35	V	
		$V_{CC}=6.0V$	-	-	1.8	V	
LOW-level output voltage	V_{OL}	$V_I=V_{IH}$ or V_{IL}	$I_O=20\mu A$; $V_{CC}=2.0V$	-	-	0.1	V
			$I_O=20\mu A$; $V_{CC}=4.5V$	-	-	0.1	V
			$I_O=20\mu A$; $V_{CC}=6.0V$	-	-	0.1	V
			$I_O=4.0mA$; $V_{CC}=4.5V$	-	-	0.4	V
			$I_O=5.2mA$; $V_{CC}=6.0V$	-	-	0.4	V
input leakage current	I_I	$V_I=V_{CC}$ or GND; $V_{CC}=6.0V$	-	-	± 1.0	μA	
OFF-state output current	I_{OZ}	per input pin; $V_I=V_{IL}$; $V_O=V_{CC}$ or GND; other inputs at V_{CC} or GND; $V_{CC}=6.0V$; $I_O=0A$	-	-	± 10	μA	
supply current	I_{CC}	$V_I=V_{CC}$ or GND; $I_O=0A$; $V_{CC}=6.0V$	-	-	40	μA	
SN74HCT05							
HIGH-level input voltage	V_{IH}	$V_{CC}=4.5V$ to $5.5V$	2.0	-	-	V	
LOW-level input voltage	V_{IL}	$V_{CC}=4.5V$ to $5.5V$	-	-	0.8	V	
LOW-level output voltage	V_{OL}	$V_I=V_{IH}$ or V_{IL} ; $V_{CC}=4.5V$	$I_O=20\mu A$	-	-	0.1	V
			$I_O=4.0mA$	-	-	0.4	V
input leakage current	I_I	$V_I=V_{CC}$ or GND; $V_{CC}=5.5V$	-	-	± 1.0	μA	
OFF-state output current	I_{OZ}	per input pin; $V_I=V_{IL}$; $V_O=V_{CC}$ or GND; other inputs at V_{CC} or GND; $V_{CC}=5.5V$; $I_O=0A$	-	-	± 10	μA	
supply current	I_{CC}	$V_I=V_{CC}$ or GND; $I_O=0A$; $V_{CC}=5.5V$	-	-	40	μA	



additional supply current	ΔI_{CC}	per input pin; $V_I = V_{CC} - 2.1V$; other inputs at V_{CC} or GND; $I_O = 0A$; $V_{CC} = 4.5V$ to $5.5V$	-	-	490	μA
---------------------------	-----------------	--	---	---	-----	---------

3.3.4 、 AC Characteristics 1

($T_{amb} = 25^\circ C$, GND=0V, $C_L = 50pF$, unless otherwise specified.)

Parameter	Symbol	Conditions	Min.	Typ.	Max.	Unit	
SN74HC05							
nA to nY propagation delay	t_{pd}	see Figure 4 ^[1]	$V_{CC} = 2.0V$	-	28	95	ns
			$V_{CC} = 4.5V$	-	10	19	ns
			$V_{CC} = 5.0V$; $C_L = 15pF$	-	8	-	ns
			$V_{CC} = 6.0V$	-	8	16	ns
transition time	t_t	see Figure 4 ^[2]	$V_{CC} = 2.0V$	-	19	75	ns
			$V_{CC} = 4.5V$	-	7	15	ns
			$V_{CC} = 6.0V$	-	6	13	ns
power dissipation capacitance	C_{PD}	per package; $V_I = GND$ to V_{CC} ^[3]	-	4	-	pF	
SN74HCT05							
nA to nY propagation delay	t_{pd}	see Figure 4 ^[1]	$V_{CC} = 4.5V$	-	12	24	ns
			$V_{CC} = 5.0V$; $C_L = 15pF$	-	10	-	ns
transition time	t_t	$V_{CC} = 4.5V$; see Figure 4 ^[2]	-	7	15	ns	
power dissipation capacitance	C_{PD}	per package; $V_I = GND$ to $V_{CC} - 1.5V$ ^[3]	-	4	-	pF	

Note:

[1] t_{pd} is the same as t_{PLZ} and t_{PZL} .

[2] t_t is the same as t_{THL} .

[3] C_{PD} is used to determine the dynamic power dissipation (P_D in μW).

$P_D = C_{PD} \times V_{CC}^2 \times f_i \times N + \sum (C_L \times V_{CC}^2 \times f_o)$ where:

f_i = input frequency in MHz; f_o = output frequency in MHz;

C_L = output load capacitance in pF;

V_{CC} = supply voltage in V;

N = number of inputs switching;

$\sum (C_L \times V_{CC}^2 \times f_o)$ = sum of outputs.



3.3.5 、 AC Characteristics 2

($T_{amb}=-40^{\circ}\text{C}$ to $+85^{\circ}\text{C}$, $\text{GND}=0\text{V}$, $C_L=50\text{pF}$, unless otherwise specified.)

Parameter	Symbol	Conditions	Min.	Typ.	Max.	Unit	
SN74HC05							
nA to nY propagation delay	t_{pd}	see Figure 4 ^[1]	$V_{CC}=2.0\text{V}$	-	-	120	ns
			$V_{CC}=4.5\text{V}$	-	-	24	ns
			$V_{CC}=6.0\text{V}$	-	-	20	ns
transition time	t_t	see Figure 4 ^[2]	$V_{CC}=2.0\text{V}$	-	-	95	ns
			$V_{CC}=4.5\text{V}$	-	-	19	ns
			$V_{CC}=6.0\text{V}$	-	-	16	ns
SN74HCT05							
nA to nY propagation delay	t_{pd}	see Figure 4 ^[1]	$V_{CC}=4.5\text{V}$	-	-	30	ns
transition time	t_t	$V_{CC}=4.5\text{V}$; see Figure 4 ^[2]		-	-	19	ns

Note:

[1] t_{pd} is the same as t_{PLZ} and t_{PZL} .

[2] t_t is the same as t_{THL} .

3.3.6 、 AC Characteristics 3

($T_{amb}=-40^{\circ}\text{C}$ to $+105^{\circ}\text{C}$, $\text{GND}=0\text{V}$, $C_L=50\text{pF}$, unless otherwise specified.)

Parameter	Symbol	Conditions	Min.	Typ.	Max.	Unit	
SN74HC05							
nA to nY propagation delay	t_{pd}	see Figure 4 ^[1]	$V_{CC}=2.0\text{V}$	-	-	145	ns
			$V_{CC}=4.5\text{V}$	-	-	29	ns
			$V_{CC}=6.0\text{V}$	-	-	25	ns
transition time	t_t	see Figure 4 ^[2]	$V_{CC}=2.0\text{V}$	-	-	110	ns
			$V_{CC}=4.5\text{V}$	-	-	22	ns
			$V_{CC}=6.0\text{V}$	-	-	19	ns
SN74HCT05							
nA to nY propagation delay	t_{pd}	see Figure 4 ^[1]	$V_{CC}=4.5\text{V}$	-	-	36	ns
transition time	t_t	$V_{CC}=4.5\text{V}$; see Figure 4 ^[2]		-	-	22	ns

Note:

[1] t_{pd} is the same as t_{PLZ} and t_{PZL} .

[2] t_t is the same as t_{THL} .



4、Testing Circuit

4.1、AC Testing Circuit

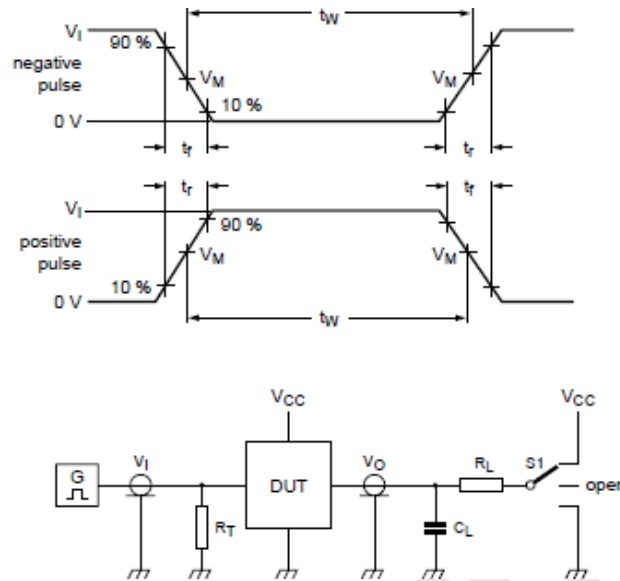

Figure 3. Test circuit for measuring switching times

Definitions for test circuit:

C_L =Load capacitance including jig and probe capacitance.

R_T =Termination resistance should be equal to the output impedance Z_o of the pulse generator.

R_L =Load resistance.

S1=Test selection switch.

4.2、AC Testing Waveforms

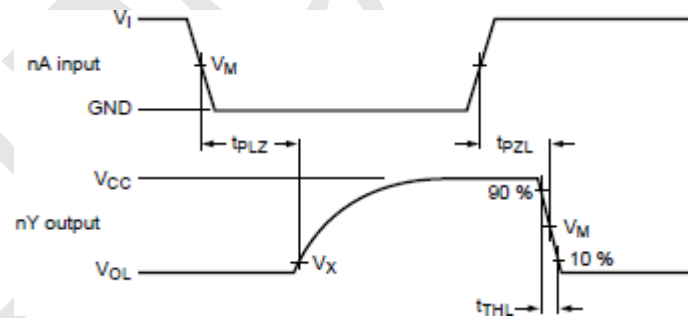

Figure 4. The input nA to output nY propagation delays and output transition times



4.3、Measurement Points

Type	Input	Output	
	V_M	V_M	V_X
SN74HC05	$0.5 \times V_{CC}$	$0.5 \times V_{CC}$	$0.1 \times V_{CC}$
SN74HCT05	1.3V	1.3V	$0.1 \times V_{CC}$

4.4、Test Data

Type	Input		Load		S1 position
	V_I	t_r, t_f	C_L	R_L	t_{pZL}, t_{PLZ}
SN74HC05	V_{CC}	6ns	15pF, 50pF	1k Ω	V_{CC}
SN74HCT05	3V	6ns	15pF, 50pF	1k Ω	V_{CC}



5、Package Information

5.1、DIP14

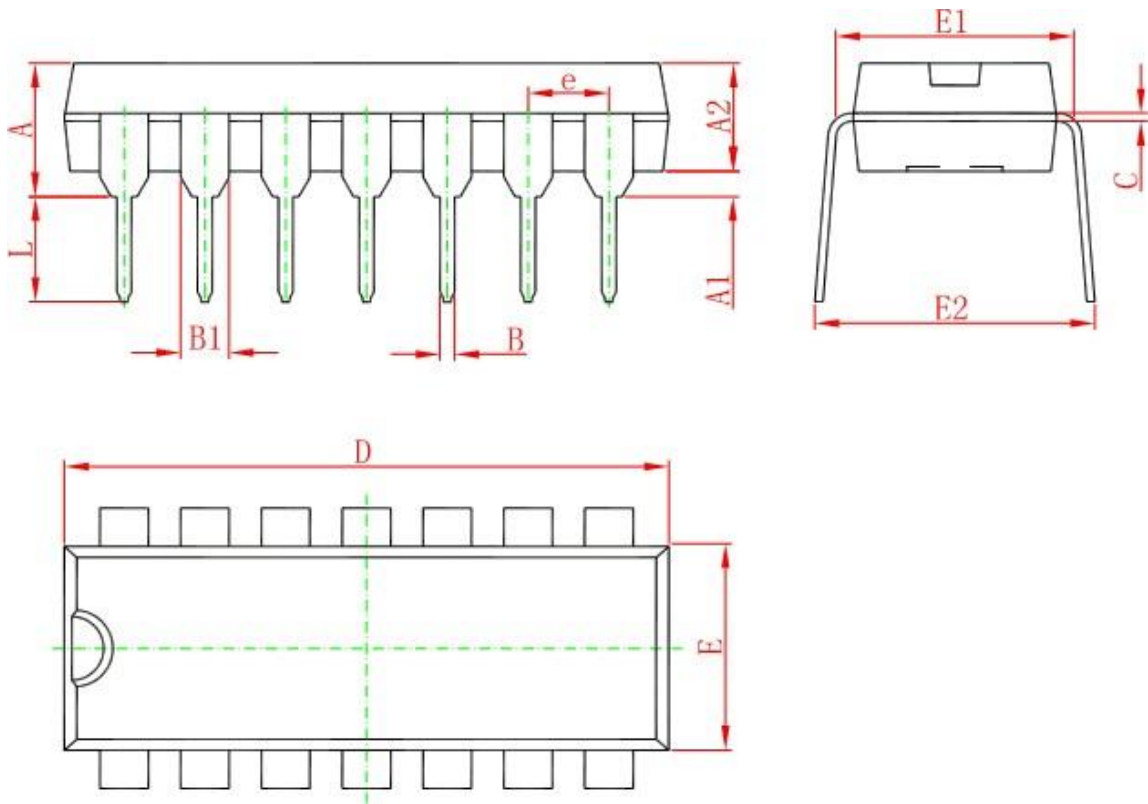

Symbol	Dimensions In Millimeters		Dimensions In Inches	
	Min	Max	Min	Max
A	3.710	4.310	0.146	0.170
A1	0.510		0.020	
A2	3.200	3.600	0.126	0.142
B	0.380	0.570	0.015	0.022
B1	1.524 (BSC)		0.060 (BSC)	
C	0.204	0.360	0.008	0.014
D	18.800	19.200	0.740	0.756
E	6.200	6.600	0.244	0.260
E1	7.320	7.920	0.288	0.312
e	2.540 (BSC)		0.100 (BSC)	
L	3.000	3.600	0.118	0.142
E2	8.400	9.000	0.331	0.354



5.2、SOP14

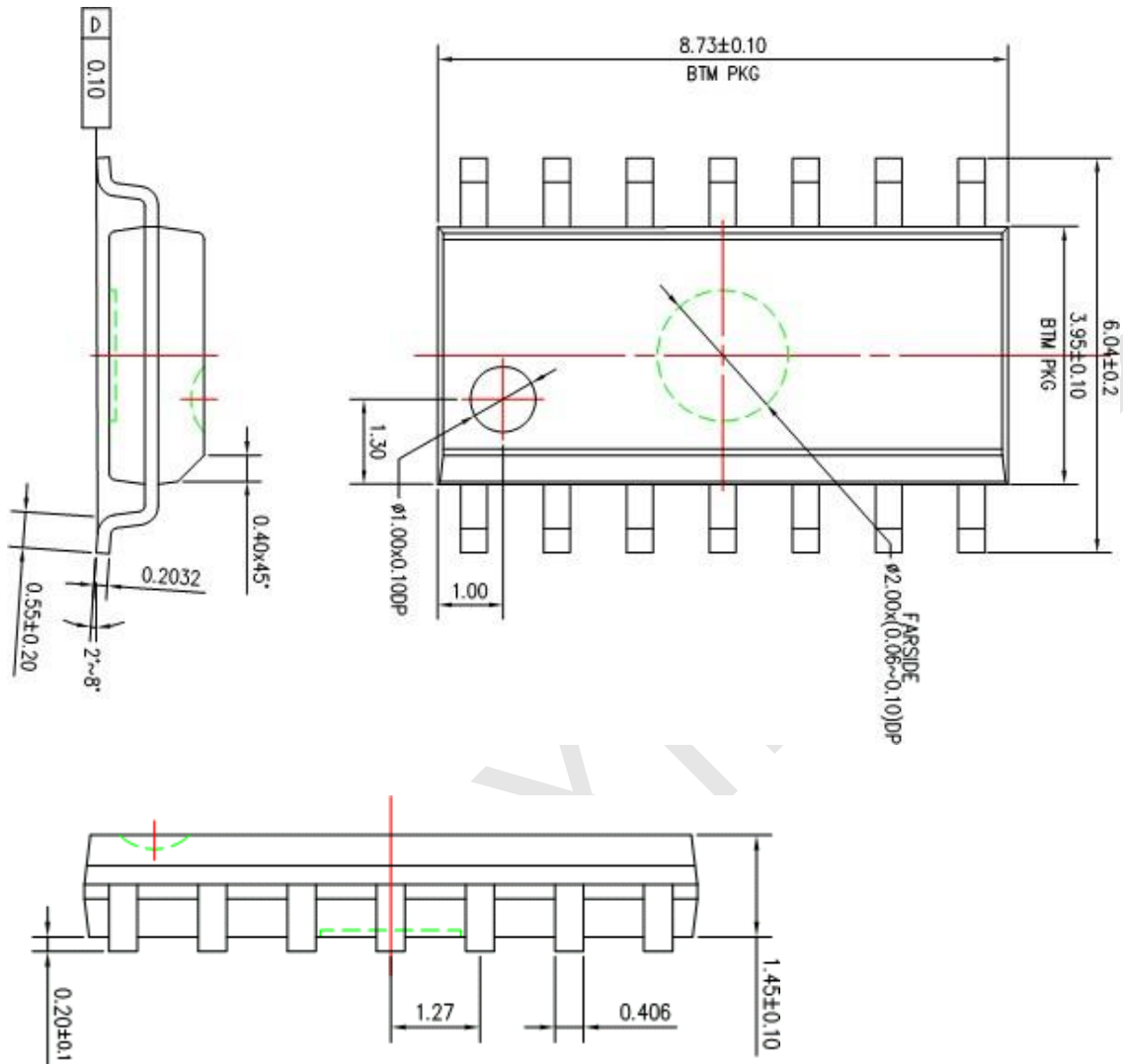



5.3、TSSOP14

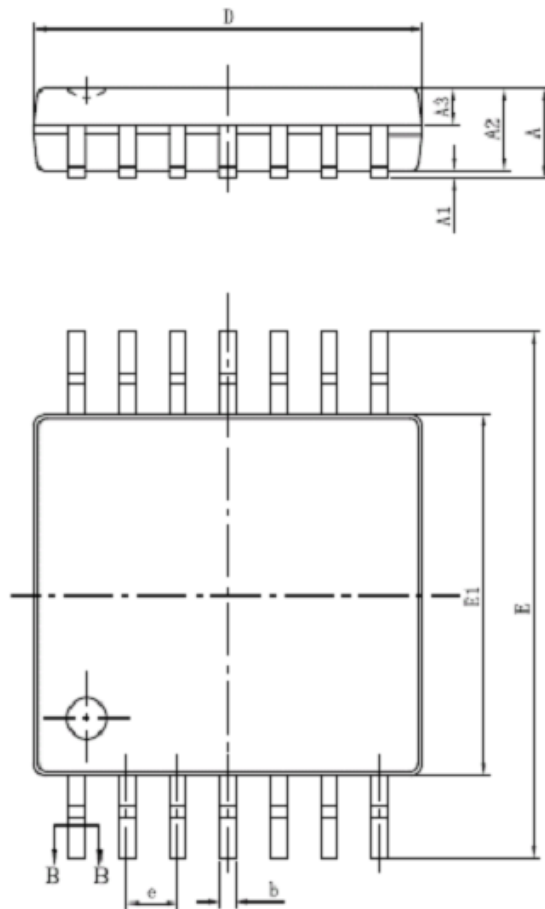

SYMBOL	MILLIMETER	
	MIN	MAX
A	—	1.20
A1	0.05	0.15
A2	0.90	1.05
A3	0.39	0.49
b	0.20	0.30
b1	0.19	0.25
c	0.13	0.19
c1	0.12	0.14
D	4.86	5.06
E1	4.30	4.50
E	6.20	6.60
e	0.65BSC	
L	0.45	0.75
L1	1.00BSC	
θ	0	8°

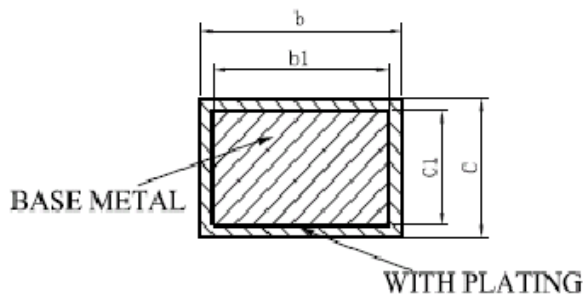

SECTION B-B



6、 Statements And Notes

6.1 、 The name and content of Hazardous substances or Elements in the product

Part name	Hazardous substances or Elements									
	Lead and lead compounds	Mercury and mercury compounds	Cadmium and cadmium compounds	Hexavalent chromium compounds	Polybrominated biphenyls	Polybrominated biphenyl ethers	Dibutyl phthalate	Butylbenzyl phthalate	Di-2-ethylhexyl phthalate	Diisobutyl phthalate
Lead frame	○	○	○	○	○	○	○	○	○	○
Plastic resin	○	○	○	○	○	○	○	○	○	○
Chip	○	○	○	○	○	○	○	○	○	○
The lead	○	○	○	○	○	○	○	○	○	○
Plastic sheet installed	○	○	○	○	○	○	○	○	○	○
explanation	○: Indicates that the content of hazardous substances or elements in the detection limit of the following the SJ/T11363-2006 standard. ×: Indicates that the content of hazardous substances or elements exceeding the SJ/T11363-2006 Standard limit requirements.									

6.2 、 Notion

Recommended carefully reading this information before the use of this product;

The information in this document are subject to change without notice;

This information is using to the reference only, the company is not responsible for any loss;

The company is not responsible for the any infringement of the third party patents or other rights of the responsibility.

X-ON Electronics

Largest Supplier of Electrical and Electronic Components

Click to view similar products for [Inverters](#) category:

Click to view products by [lingxingic](#) manufacturer:

Other Similar products are found below :

[E5-652Z](#) [NLX2G04BMX1TCG](#) [CD4009UBE](#) [TC4584BFN](#) [NL17SG14AMUTCG](#) [NLU2GU04BMX1TCG](#) [NLV17SZ14DFT2G](#)
[NLV74HC04ADTR2G](#) [NLU1G04AMUTCG](#) [NLX2G04CMUTCG](#) [NLX2G04AMUTCG](#) [NLV27WZ04DFT1G](#) [NLU1G04CMUTCG](#)
[NL17SZU04P5T5G](#) [74LVC06ADTR2G](#) [74LVC04ADR2G](#) [NLV37WZ04USG](#) [NLX3G14FMUTCG](#) [NL17SZ04P5T5G](#) [NL17SG14P5T5G](#)
[NLV27WZU04DFT2G](#) [NLV17SG14DFT2G](#) [NLVHC1G04DFT2G](#) [MC14069UBD](#) [NLU3G14CMX1TCG](#) [NLX2G14BMX1TCG](#)
[NLX2GU04AMX1TCG](#) [74HCT04DT](#) [74HCT14DT](#) [74LCX14FT\(AJ\)](#) [EG8015](#) [GN14D](#) [GN4069](#) [74HC04DM/TR](#) [HG74HC04M/TR](#)
[CD40106DM/TR](#) [CD4007BE](#) [74HC14DN](#) [74HC14DM/TR](#) [CD4069UBE](#) [74HC125M/TR](#) [CD4069UBMT/TR](#) [HG74HC04MT/TR](#)
[74HC14DMT/TR](#) [74HC04DN](#) [HT74HC04ARZ](#) [HT40106ARZ](#) [74HC14-HXY](#) [IW4069UBN](#) [RS1GT04XC5](#)