



SN74HC/HCT112

Dual JK flip-flop with set and reset; negative-edge trigger

Product Specification

Specification Revision History:

Version	Date	Description
2023-06-A0	2023-06	New
2023-11-A1	2023-11	Parameter modification



Contents

1、 General Description.....	1
2、 Block Diagram And Pin Description	4
2.1、 Block Diagram	4
2.2、 Pin Configurations	4
2.3、 Pin Description.....	5
3、 Electrical Parameter	6
3.1、 Absolute Maximum Ratings.....	6
3.2、 Electrical Characteristics.....	6
3.2.1、 DC Characteristics 1	6
3.2.2、 DC Characteristics 2.....	7
3.3.3、 AC Characteristics 1	8
3.3.4、 AC Characteristics 2.....	9
4、 Testing Circuit	12
4.1、 DC Testing Circuit.....	12
4.2、 AC Testing Circuit.....	12
4.3、 AC Testing Waveforms.....	13
4.4、 Measurement Points	14
5、 Package Information	15
5.1、 DIP16.....	15
5.2、 SOP16.....	16
5.3、 TSSOP16.....	17
6、 Statements And Notes	18
6.1、 The name and content of Hazardous substances or Elements in the product	18
6.2、 Notes.....	18



灵星芯微 集成电路

1、General Description

The SN74HC/HCT112 is a dual negative-edge triggered JK flip-flop.

Features:

- Supply voltage range:
SN74HC112: 2~6V
SN74HCT112: 4.5~5.5V
- Input levels:
SN74HC112: CMOS level
SN74HCT112: TTL level
- Temperature range: -40°C to +125°C
- Packaging information: DIP16/SOP16/TSSOP16



Ordering Information:

Tube packing specifications:

Part number	Packaging form	Marking code	Tube quantity	Boxed tube quantity	Boxed quantity	Notes
SN74HC112N(LX)	DIP16	SN74HC112N	25 PCS/tube	40 tube/box	1000 PCS/box	Dimensions of plastic enclosure: 19.0mm×6.4mm Pin spacing: 2.54mm
SN74HCT112N(LX)	DIP16	SN74HCT112N	25 PCS/tube	40 tube/box	1000 PCS/box	Dimensions of plastic enclosure: 19.0mm×6.4mm Pin spacing: 2.54mm
SN74HC112D(LX)	SOP16	HC112	50 PCS/tube	200 tube/box	10000 PCS/box	Dimensions of plastic enclosure: 10.0mm×3.9mm Pin spacing: 1.27mm
SN74HCT112D(LX)	SOP16	HCT112	50 PCS/tube	200 tube/box	10000 PCS/box	Dimensions of plastic enclosure: 10.0mm×3.9mm Pin spacing: 1.27mm
SN74HC112P(LX)	TSSOP16	HC112	96 PCS/tube	200 tube/box	19200 PCS/box	Dimensions of plastic enclosure: 5.0mm×4.4mm Pin spacing: 0.65mm
SN74HCT112P(LX)	TSSOP16	HCT112	96 PCS/tube	200 tube/box	19200 PCS/box	Dimensions of plastic enclosure: 5.0mm×4.4mm Pin spacing: 0.65mm



灵星芯微 精密制程

Reel packing specifications:

Part number	Packaging form	Marking code	Reel quantity	Boxed reel quantity	Notes
SN74HC112DR(LX)	SOP16	HC112	2500 PCS/reel	5000 PCS/box	Dimensions of plastic enclosure: 10.0mm×3.9mm Pin spacing:1.27mm
SN74HCT112DR(LX)	SOP16	HCT112	2500 PCS/reel	5000 PCS/box	Dimensions of plastic enclosure: 10.0mm×3.9mm Pin spacing:1.27mm
SN74HC112PR(LX)	TSSOP16	HC112	5000 PCS/reel	10000 PCS/box	Dimensions of plastic enclosure: 5.0mm×4.4mm Pin spacing:0.65mm
SN74HCT112PR(LX)	TSSOP16	HCT112	5000 PCS/reel	10000 PCS/box	Dimensions of plastic enclosure: 5.0mm×4.4mm Pin spacing:0.65mm

Note 1: "XX" refers to variable content, meaning year and package batch serial number.

Note 2: If the physical information is inconsistent with the ordering information, please refer to the actual product.



2、Block Diagram And Pin Description

2.1、Block Diagram

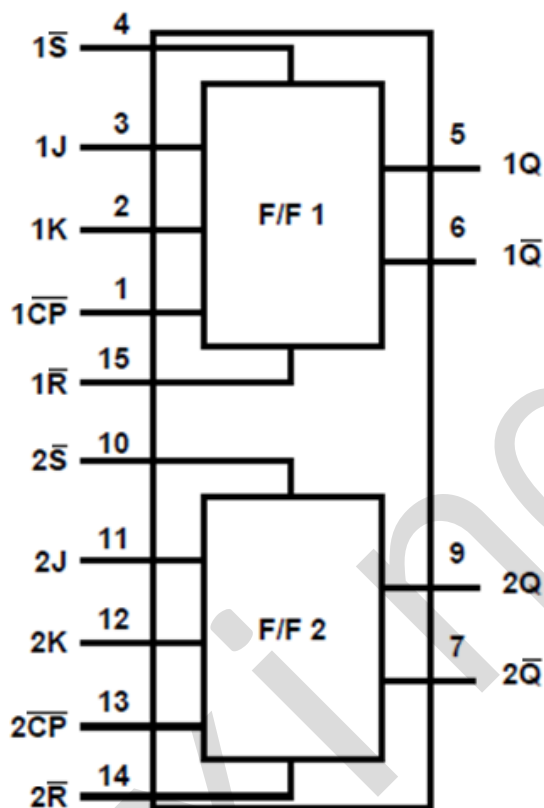
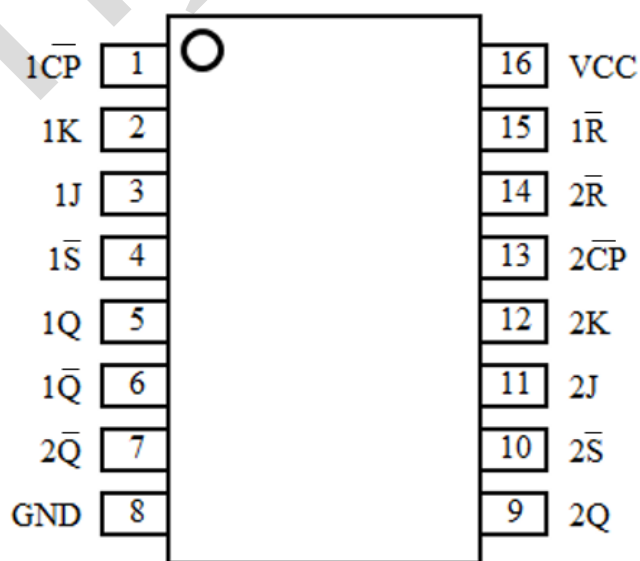

Figure 1. Functional diagram

2.2、Pin Configurations





2.3、Pin Description

Pin No.	Pin Name	Description
1	$\overline{1CP}$	clock input (HIGH-to-LOW; edge-triggered)
2	1K	data input
3	1J	data input
4	$\overline{1S}$	set input (active LOW)
5	1Q	true flip-flop output
6	$\overline{1Q}$	complement flip-flop output
7	$\overline{2Q}$	complement flip-flop output
8	GND	ground (0V)
9	2Q	true flip-flop output
10	$\overline{2S}$	set input (active LOW)
11	2J	data input
12	2K	data input
13	$\overline{2CP}$	clock input (HIGH-to-LOW; edge-triggered)
14	$\overline{2R}$	reset input (active LOW)
15	$\overline{1R}$	reset input (active LOW)
16	VCC	supply voltage

2.4、Function Table

Inputs					Outputs	
\overline{S}	\overline{R}	\overline{CP}	J	K	Q	\overline{Q}
L	H	X	X	X	H	L
H	L	X	X	X	L	H
L	L	X	X	X	H(Note 1)	H(Note 1)
H	H	↓	L	L	No Change	
H	H	↓	H	L	H	L
H	H	↓	L	H	L	H
H	H	↓	H	H	Toggle	
H	H	H	X	X	No Change	

H= High Level (Steady State)

L= Low Level (Steady State)

X= Don't Care

↓ = High-to-Low Transition

NOTE 1: Output states unpredictable if both S and R go High simultaneously after both being low at the same time



3、Electrical Parameter

3.1、Absolute Maximum Ratings

($T_{amb}=25^{\circ}\text{C}$, All voltage referenced to V_{ss} , unless otherwise specified)

Parameter	Symbol	Conditions	Min.	Max.	Unit
supply voltage	V_{CC}	-	-0.5	+7	V
supply current	I_{CC}	-	-	50	mA
ground current	I_{GND}	-	-50	-	mA
input clamping current	I_{IK}	$V_I < -0.5\text{V}$ or $V_I > V_{CC}+0.5\text{V}$	-	± 20	mA
output clamping current	I_{OK}	$V_O < -0.5\text{V}$ or $V_O > V_{CC}+0.5\text{V}$	-	± 20	mA
output current	I_O	$-0.5\text{V} < V_O < V_{CC}+0.5\text{V}$	-	± 25	mA
storage temperature	T_{stg}	-	-65	+150	$^{\circ}\text{C}$
soldering temperature	T_L	10s	DIP	245	$^{\circ}\text{C}$
			SOP/TSSOP	260	

3.2、Electrical Characteristics

3.2.1、DC Characteristics 1

($T_{amb}=-40^{\circ}\text{C}$ to $+85^{\circ}\text{C}$, voltages are referenced to V_{SS} (ground=0V), unless otherwise specified.)

Parameter	Symbol	V_{CC}	Conditions	Min.	Typ.	Max.	Unit
SN74HC112							
HIGH-level input voltage	V_{IH}	2.0V	-	1.5	1.2	-	V
		4.5V	-	3.15	2.4	-	V
		6.0V	-	4.2	3.2	-	V
LOW-level input voltage	V_{IL}	2.0V	-	-	0.8	0.5	V
		4.5V	-	-	2.1	1.35	V
		6.0V	-	-	2.8	1.8	V
HIGH-level output voltage	V_{OH}	2.0V	$I_O=-20\mu\text{A}$	1.9	2.0	-	V
		4.5V	$I_O=-20\mu\text{A}$	4.4	4.5	-	V
		6.0V	$I_O=-20\mu\text{A}$	5.9	6.0	-	V
		4.5V	$I_O=-4.0\text{mA}$	3.84	4.32	-	V
		6.0V	$I_O=-5.2\text{mA}$	5.34	5.81	-	V
LOW-level output voltage	V_{OL}	2.0V	$I_O=20\mu\text{A}$	-	0	0.1	V
		4.5V	$I_O=20\mu\text{A}$	-	0	0.1	V
		6.0V	$I_O=20\mu\text{A}$	-	0	0.1	V
		4.5V	$I_O=4.0\text{mA}$	-	0.15	0.33	V
		6.0V	$I_O=5.2\text{mA}$	-	0.16	0.33	V
input leakage current	I_I	6.0V	$V_I=V_{CC}$ or GND	-	-	± 1	μA
supply current	I_{CC}	6.0V	$V_I=V_{CC}$ or GND; $I_O=0\text{A}$	-	-	80	μA
SN74HCT112							
HIGH-level input voltage	V_{IH}	4.5~5.5V	-	2.0	1.6	-	V
LOW-level input voltage	V_{IL}	4.5~5.5V	-	-	1.2	0.8	V
HIGH-level	V_{OH}	4.5V	$I_O=-20\mu\text{A}$	4.4	4.5	-	V



output voltage			$I_O=-4.0mA$	3.84	4.32	-	V
LOW-level output voltage	V_{OL}	4.5V	$I_O=20\mu A$	-	0	0.1	V
			$I_O=4.0mA$	-	0.15	0.33	V
input leakage current	I_I	5.5V	$V_I=V_{CC}$ or GND	-	-	± 1	μA
supply current	I_{CC}	6.0V	$V_I=V_{CC}$ or GND; $I_O=0A$	-	-	80	μA
additional supply current	ΔI_{CC}	4.5~5.5V	One input at $V_I=V_{CC}-2.1V$; Other inputs at V_{CC} or GND; $I_O=0A$	-	-	135	μA

3.2.2、DC Characteristics 2

($T_{amb}=-40^{\circ}C$ to $+125^{\circ}C$, voltages are referenced to V_{SS} (ground=0V), unless otherwise specified.)

Parameter	Symbol	V_{CC}	Conditions	Min.	Typ.	Max.	Unit
SN74HC112							
HIGH-level input voltage	V_{IH}	2.0V	-	1.5	-	-	V
		4.5V	-	3.15	-	-	V
		6.0V	-	4.2	-	-	V
LOW-level input voltage	V_{IL}	2.0V	-	-	-	0.5	V
		4.5V	-	-	-	1.35	V
		6.0V	-	-	-	1.8	V
HIGH-level output voltage	V_{OH}	2.0V	$I_O=-20\mu A$	1.9	-	-	V
		4.5V	$I_O=-20\mu A$	4.4	-	-	V
		6.0V	$I_O=-20\mu A$	5.9	-	-	V
		4.5V	$I_O=-4.0mA$	3.7	-	-	V
		6.0V	$I_O=-5.2mA$	5.2	-	-	V
LOW-level output voltage	V_{OL}	2.0V	$I_O=20\mu A$	-	-	0.1	V
		4.5V	$I_O=20\mu A$	-	-	0.1	V
		6.0V	$I_O=20\mu A$	-	-	0.1	V
		4.5V	$I_O=4.0mA$	-	-	0.4	V
		6.0V	$I_O=5.2mA$	-	-	0.4	V
input leakage current	I_I	6.0V	$V_I=V_{CC}$ or GND	-	-	± 1	μA
supply current	I_{CC}	6.0V	$V_I=V_{CC}$ or GND; $I_O=0A$	-	-	160	μA
SN74HCT112							
HIGH-level input voltage	V_{IH}	4.5~5.5V	-	2.0	-	-	V
LOW-level input voltage	V_{IL}	4.5~5.5V	-	-	-	0.8	V
HIGH-level output voltage	V_{OH}	4.5V	$I_O=-20\mu A$	4.4	-	-	V
			$I_O=-4.0mA$	3.7	-	-	V
LOW-level output voltage	V_{OL}	4.5V	$I_O=20\mu A$	-	-	0.1	V
			$I_O=4.0mA$	-	-	0.4	V
input leakage current	I_I	5.5V	$V_I=V_{CC}$ or GND	-	-	± 1	μA
supply current	I_{CC}	6.0V	$V_I=V_{CC}$ or GND; $I_O=0A$	-	-	160	μA
additional	ΔI_{CC}	4.5~	One input at $V_I=V_{CC}-2.1V$;	-	-	147	μA



supply current		5.5V	Other inputs at V _{CC} or GND; I _O =0A				
----------------	--	------	---	--	--	--	--

3.3.3、AC Characteristics 1

(T_{amb}=-40°C to +85°C, V_{SS}=0V, unless otherwise specified.)

Parameter	Symbol	V _{CC}	Conditions	Min.	Typ.	Max.	Unit	
SN74HC112								
nCP to nQ propagation delay		2.0V	C _L =50pF	see Figure 5	-	55	220	ns
		4.5V	C _L =50pF		-	20	44	ns
		5.0V	C _L =15pF		-	17	-	ns
		6.0V	C _L =50pF		-	16	37	ns
nCP to nQ propagation delay	t _{PLH} , t _{PHL}	2.0V	C _L =50pF	see Figure 5	-	55	220	ns
		4.5V	C _L =50pF		-	20	44	ns
		5.0V	C _L =15pF		-	17	-	ns
		6.0V	C _L =50pF		-	16	37	ns
nR to nQ、nQ propagation delay		2.0V	C _L =50pF	see Figure 6	-	58	225	ns
		4.5V	C _L =50pF		-	21	45	ns
		5.0V	C _L =15pF		-	18	-	ns
		6.0V	C _L =50pF		-	17	38	ns
nS to nQ、nQ propagation delay		2.0V	C _L =50pF	see Figure 6	-	50	295	ns
		4.5V	C _L =50pF		-	18	39	ns
		5.0V	C _L =15pF		-	15	-	ns
		6.0V	C _L =50pF		-	14	33	ns
transition time	t _{THL} , t _{TLH}	2.0V	C _L =50pF	see Figure 5	-	19	95	ns
		4.5V	C _L =50pF		-	7	19	ns
		6.0V	C _L =50pF		-	6	16	ns
nCP HIGH or LOW pulse width	t _w	2.0V	C _L =50pF	see Figure 5	100	22	-	ns
		4.5V	C _L =50pF		20	8	-	ns
		6.0V	C _L =50pF		17	6	-	ns
nS,nR LOW pulse width		2.0V	C _L =50pF	see Figure 6	100	22	-	ns
		4.5V	C _L =50pF		20	8	-	ns
		6.0V	C _L =50pF		17	6	-	ns
nR to nCP recovery time	t _{rec}	2.0V	C _L =50pF	see Figure 6	125	22	-	ns
		4.5V	C _L =50pF		25	8	-	ns
		6.0V	C _L =50pF		21	6	-	ns
nS to nCP recovery time		2.0V	C _L =50pF	see Figure 6	100	-19	-	ns
		4.5V	C _L =50pF		20	-7	-	ns
		6.0V	C _L =50pF		17	-6	-	ns
nJ and nK to nCP set-up time	t _{su}	2.0V	C _L =50pF	see Figure 5	100	19	-	ns
		4.5V	C _L =50pF		20	7	-	ns
		6.0V	C _L =50pF		17	6	-	ns
nJ and nK to nCP hold time	t _h	2.0V	C _L =50pF	see Figure 5	0	-11	-	ns
		4.5V	C _L =50pF		0	-4	-	ns
		6.0V	C _L =50pF		0	-3	-	ns
maxiumum	f _{max}	2.0V	C _L =50pF	see Figure 5	4.8	20	-	MHz



frequency		4.5V	$C_L=50\text{pF}$		24	60	-	MHz
		5.0V	$C_L=15\text{pF}$		-	66	-	MHz
		6.0V	$C_L=50\text{pF}$		28	71	-	MHz
SN74HCT112								
\overline{nCP} to \overline{nQ} propagation delay	t_{PLH}, t_{PHL}	4.5V	$C_L=50\text{pF}$	see Figure 5	-	21	44	ns
		5.0V	$C_L=15\text{pF}$		-	19	-	ns
\overline{nCP} to \overline{nQ} propagation delay		4.5V	$C_L=50\text{pF}$	see Figure 5	-	23	50	ns
		5.0V	$C_L=15\text{pF}$		-	19	-	ns
\overline{nR} to \overline{nQ} 、 \overline{nQ} propagation delay		4.5V	$C_L=50\text{pF}$	see Figure 6	-	22	46	ns
		5.0V	$C_L=15\text{pF}$		-	19	-	ns
\overline{nS} to \overline{nQ} 、 \overline{nQ} propagation delay		4.5V	$C_L=50\text{pF}$	see Figure 6	-	18	40	ns
		5.0V	$C_L=15\text{pF}$		-	15	-	ns
transition time		t_{THL}, t_{TLH}	4.5V	$C_L=50\text{pF}$	see Figure 5	-	7	19
\overline{nCP} HIGH or LOW pulse width	t_w	4.5V	$C_L=50\text{pF}$	see Figure 5	20	8	-	ns
$\overline{nS}, \overline{nR}$ LOW pulse width		4.5V	$C_L=50\text{pF}$	see Figure 6	23	10	-	ns
\overline{nR} to \overline{nCP} recovery time	t_{rec}	4.5V	$C_L=50\text{pF}$	see Figure 6	25	11	-	ns
\overline{nS} to \overline{nCP} recovery time		4.5V	$C_L=50\text{pF}$	see Figure 6	25	-8	-	ns
\overline{nJ} and \overline{nK} to \overline{nCP} set-up time	t_{su}	4.5V	$C_L=50\text{pF}$	see Figure 5	20	7	-	ns
\overline{nJ} and \overline{nK} to \overline{nCP} hold time	t_h	4.5V	$C_L=50\text{pF}$	see Figure 5	0	-7	-	ns
maximum frequency	f_{max}	4.5V	$C_L=50\text{pF}$	see Figure 5	24	64	-	MHz
		5.0V	$C_L=15\text{pF}$		-	70	-	MHz

3.3.4、AC Characteristics 2

($T_{amb}=-40^{\circ}\text{C}$ to $+125^{\circ}\text{C}$, $V_{SS}=0\text{V}$, unless otherwise specified.)

Parameter	Symbol	V_{CC}	Conditions	Min.	Typ.	Max.	Unit	
SN74HC112								
\overline{nCP} to \overline{nQ} propagation delay	t_{PLH}, t_{PHL}	2.0V	$C_L=50\text{pF}$	see Figure 3	-	-	265	ns
		4.5V	$C_L=50\text{pF}$		-	-	53	ns
		6.0V	$C_L=50\text{pF}$		-	-	45	ns
\overline{nCP} to \overline{nQ} propagation delay		2.0V	$C_L=50\text{pF}$	see Figure 3	-	-	265	ns
		4.5V	$C_L=50\text{pF}$		-	-	53	ns
		6.0V	$C_L=50\text{pF}$		-	-	45	ns
\overline{nR} to \overline{nQ} 、 \overline{nQ} propagation		2.0V	$C_L=50\text{pF}$	see Figure 4	-	-	270	ns
		4.5V	$C_L=50\text{pF}$		-	-	54	ns



delay		6.0V	$C_L=50pF$		-	-	46	ns
$\bar{n}S$ to $\bar{n}Q$ 、 $\bar{n}Q$ propagation delay		2.0V	$C_L=50pF$	see Figure 4	-	-	235	ns
		4.5V	$C_L=50pF$		-	-	47	ns
		6.0V	$C_L=50pF$		-	-	40	ns
		6.0V	$C_L=50pF$		-	-	40	ns
transition time	t_{THL}, t_{TLH}	2.0V	$C_L=50pF$	see Figure 3	-	-	110	ns
		4.5V	$C_L=50pF$		-	-	22	ns
		6.0V	$C_L=50pF$		-	-	19	ns
$\bar{n}CP$ HIGH or LOW pulse width	t_w	2.0V	$C_L=50pF$	see Figure 3	120	-	-	ns
		4.5V	$C_L=50pF$		24	-	-	ns
		6.0V	$C_L=50pF$		20	-	-	ns
$\bar{n}S, \bar{n}R$ LOW pulse width	t_w	2.0V	$C_L=50pF$	see Figure 4	120	-	-	ns
		4.5V	$C_L=50pF$		24	-	-	ns
		6.0V	$C_L=50pF$		20	-	-	ns
$\bar{n}R$ to $\bar{n}CP$ recovery time	t_{rec}	2.0V	$C_L=50pF$	see Figure 4	150	-	-	ns
		4.5V	$C_L=50pF$		30	-	-	ns
		6.0V	$C_L=50pF$		26	-	-	ns
$\bar{n}S$ to $\bar{n}CP$ recovery time	t_{rec}	2.0V	$C_L=50pF$	see Figure 4	120	-	-	ns
		4.5V	$C_L=50pF$		24	-	-	ns
		6.0V	$C_L=50pF$		20	-	-	ns
$\bar{n}J$ and $\bar{n}K$ to $\bar{n}CP$ set-up time	t_{su}	2.0V	$C_L=50pF$	see Figure 3	120	-	-	ns
		4.5V	$C_L=50pF$		24	-	-	ns
		6.0V	$C_L=50pF$		20	-	-	ns
$\bar{n}J$ and $\bar{n}K$ to $\bar{n}CP$ hold time	t_h	2.0V	$C_L=50pF$	see Figure 3	0	-	-	ns
		4.5V	$C_L=50pF$		0	-	-	ns
		6.0V	$C_L=50pF$		0	-	-	ns
maximum frequency	f_{max}	2.0V	$C_L=50pF$	see Figure 3	4.0	-	-	MHZ
		4.5V	$C_L=50pF$		20	-	-	MHZ
		6.0V	$C_L=50pF$		24	-	-	NHZ

SN74HCT112

$\bar{n}CP$ to $\bar{n}Q$ propagation delay	t_{PLH}, t_{PHL}	4.5V	$C_L=50pF$	see Figure 3	-	-	53	ns
$\bar{n}CP$ to $\bar{n}Q$ propagation delay		4.5V	$C_L=50pF$	see Figure 3	-	-	60	ns
$\bar{n}R$ to $\bar{n}Q$ 、 $\bar{n}Q$ propagation delay		4.5V	$C_L=50pF$	see Figure 4	-	-	56	ns
$\bar{n}S$ to $\bar{n}Q$ 、 $\bar{n}Q$ propagation delay		4.5V	$C_L=50pF$	see Figure 4	-	-	48	ns
transition time	t_{THL}, t_{TLH}	4.5V	$C_L=50pF$	see Figure 3	-	-	22	ns
$\bar{n}CP$ HIGH or LOW pulse width	t_w	4.5V	$C_L=50pF$	see Figure 3	24	-	-	ns
$\bar{n}S, \bar{n}R$ LOW		4.5V	$C_L=50pF$	see Figure 4	27	-	-	ns



灵星芯微 集成电路

pulse width								
nR to nCP recovery time	trec	4.5V	C _L =50pF	see Figure 4	30	-	-	ns
nS to nCP recovery time		4.5V	C _L =50pF	see Figure 4	30	-	-	ns
nJ and nK to n CP set-up time	tsu	4.5V	C _L =50pF	see Figure 3	24	-	-	ns
nJ and nK to n CP hold time	th	4.5V	C _L =50pF	see Figure 3	0	-	-	ns
maximum frequency	fmax	4.5V	C _L =50pF	see Figure 3	20	-	-	MHZ

4、Testing Circuit

4.1、DC Testing Circuit

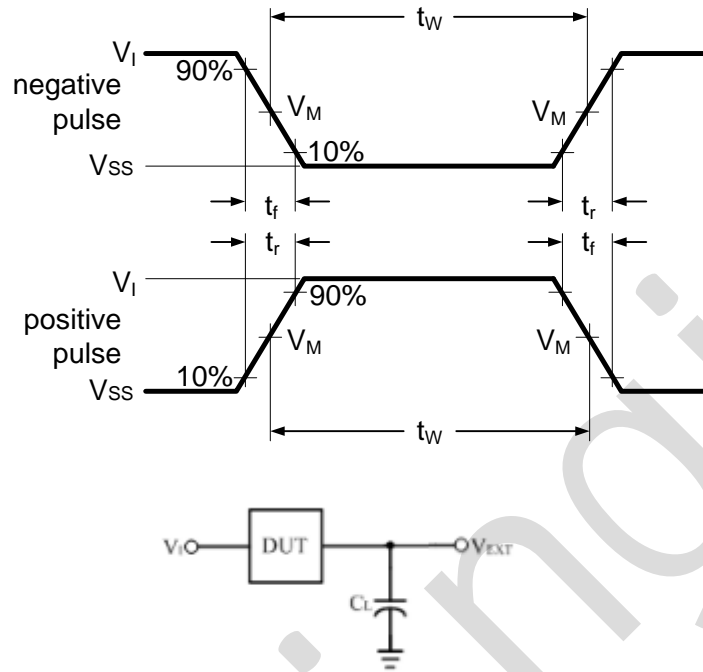

Figure 2 Load circuit

C_L includes probe and jig capacitance.

4.2、AC Testing Circuit

Type	Input		Load	V_{EXT}		
	V_I	$t_r = t_f$	C_L	t_{PLH}/t_{PHL}	t_{PLZ}/t_{PZL}	t_{PHZ}/t_{PZH}
SN74HC112	V_{CC}	6.0ns	50pF	Open	V_{CC}	GND
SN74HCT112	3.0V	6.0ns	50pF	Open	V_{CC}	GND



4.3、AC Testing Waveforms

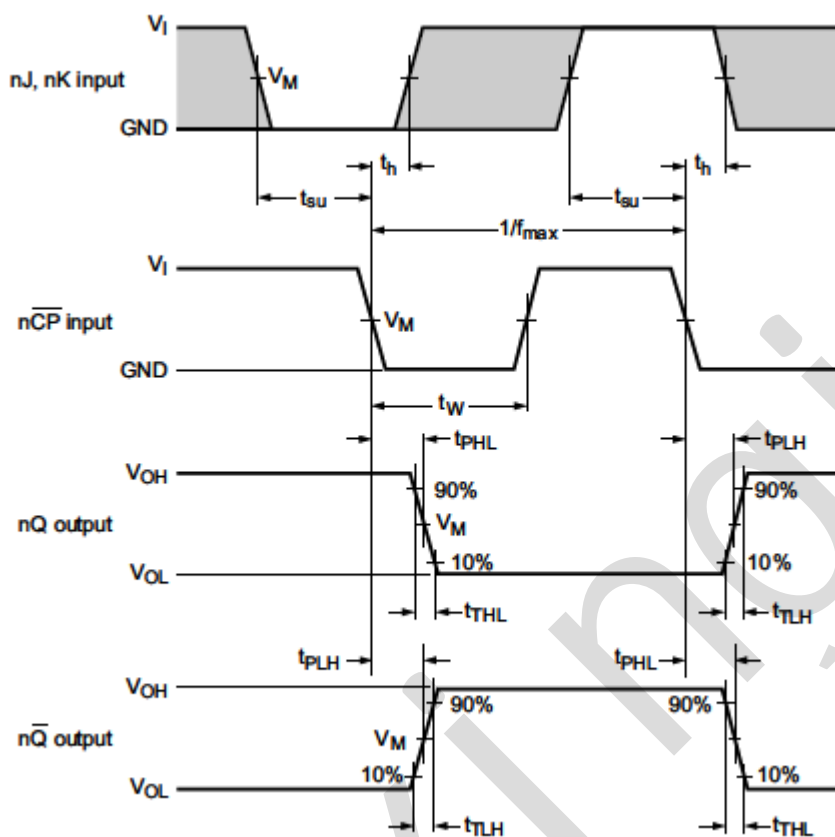

Figure 3 Clock propagation delays, output transition time, pulse width, set-up, hold times, and maximum frequency

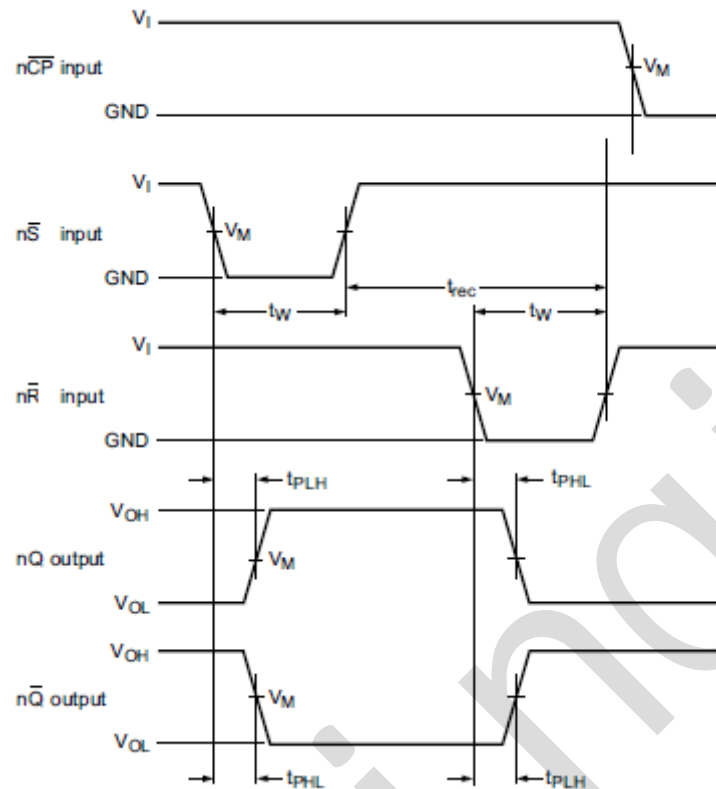

Figure 4 Set and reset propagation delays, pulse widths and recovery time

4.4. Measurement Points

Type	Input	Output		
	V_M	V_M	V_X	V_Y
SN74HC112	$0.5 \times V_{CC}$	$0.5 \times V_{CC}$	$0.1 \times V_{CC}$	$0.9 \times V_{CC}$
SN74HCT112	1.3V	1.3V	$0.1 \times V_{CC}$	$0.9 \times V_{CC}$



5、Package Information

5.1、DIP16

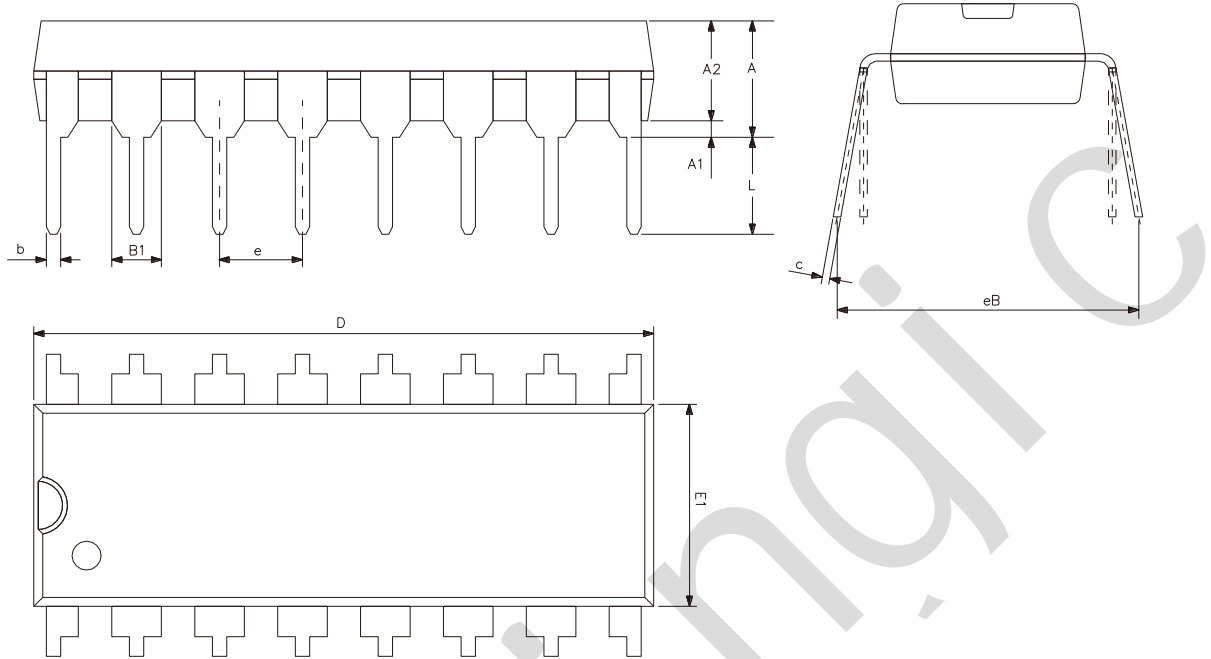

Symbol	Dimensions (mm)	
	Min.	Max.
A2	3.20	3.60
A1	0.51	-
A	3.60	5.33
L	3.00	3.60
b	0.36	0.56
B1	1.52	
D	18.80	19.94
E1	6.20	6.60
e	2.54	
c	0.20	0.36
eB	7.62	9.30



灵星芯微 精芯经营

5.2、SOP16

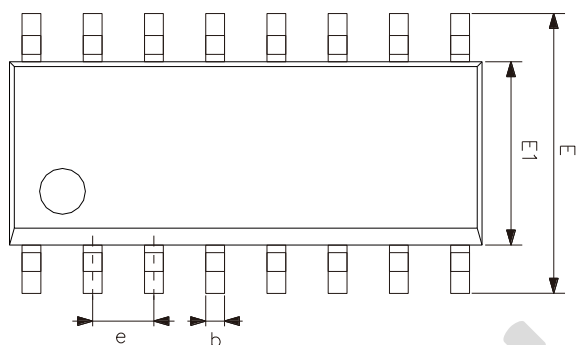
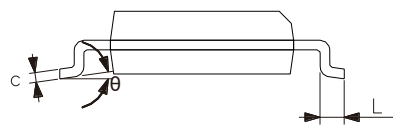
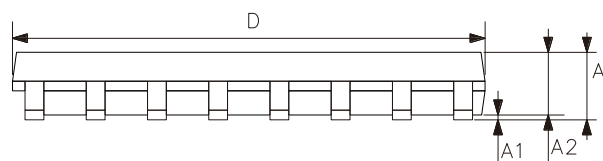

Symbol	Dimensions (mm)	
	Min.	Max.
A	1.35	1.80
A1	0.10	0.25
A2	1.25	1.55
b	0.33	0.51
c	0.19	0.25
D	9.50	10.10
E	5.80	6.30
E1	3.70	4.10
e	1.27	
L	0.35	0.89
θ	0°	8°



5.3、TSSOP16

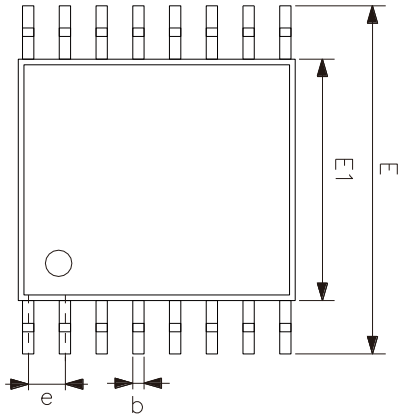
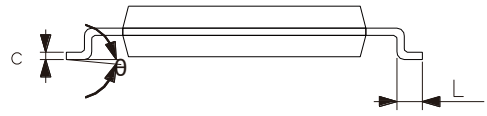
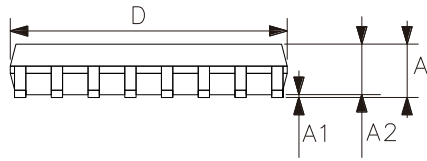

Symbol	Dimensions (mm)	
	Min.	Max.
A	-	1.20
A1	0.05	0.15
A2	0.80	1.05
b	0.19	0.30
c	0.09	0.20
D	4.90	5.10
E1	4.30	4.50
E	6.20	6.60
e	0.65	
L	0.45	0.75
θ	0°	8°

X-ON Electronics

Largest Supplier of Electrical and Electronic Components

Click to view similar products for [Flip-Flops](#) category:

Click to view products by [lingxingic](#) manufacturer:

Other Similar products are found below :

[NLV74HC74ADTR2G](#) [74F574SC](#) [NLV14013BDR2G](#) [NLV74HC74ADR2G](#) [MC10EP131MNG](#) [MC74AC74DTR2](#) [74VHC574FT\(BJ\)](#)
[HT4093ARZ](#) [SN74HC374ANSR](#) [CD4528BE](#) [CD4027BE](#) [RS74HC74XQ](#) [RS1G79XC5](#) [CD40106BM-JSM](#) [74HCT273PW-Q100J](#)
[CLVC2G74QDCURG4Q1](#) [CD4067TA24.TB](#) [CD4013SA.TR](#) [AIP74HCT14TA14.TB](#) [CD4013BPWRG](#) [AiP74LVC74TA14.TB](#)
[CD4013BDRG](#) [CD4528SA16.TR](#) [AIP74HC273SA.TB](#) [SN74HCS74QDYRQ1](#) [CD4013TA14.TB](#) [SN74LS107N](#) [SN74LS374DWR](#)
[SN74LVC2G14DC\(LX\)](#) [74VHCT574AFT](#) [TC4013BF\(EL,N,F\)](#) [74VHCT9541AFT](#) [74LCX374FT\(AJ\)](#) [TC7WZ74FK,LXGJ\(CT](#)
[74LCX374FT](#) [74VHC174FT\(TB,BJ\)](#) [TC7WH74FK,LJ](#) [SN74HC374PW\(LX\)](#) [SN74LVC1G17DC\(LX\)](#) [SN74HC174DR\(LX\)](#)
[SN74HC112N\(LX\)](#) [SN74HC74DR\(LX\)](#) [CD40174BE\(LX\)](#) [CD40175BE\(LX\)](#) [SN74LS374N](#) [SN74HC173N](#) [SN74HC107DR\(LX\)](#)
[SN74HC107N\(LX\)](#) [SN74LS174DR\(LX\)](#) [SN74LS273N\(LX\)](#)