



SN74HC/HCT13 (LX) Dual 4-Input Nand Schmitt Trigger

Product Specification

Specification Revision History:

Version	Date	Description
2023-12-A0	2023-12	New
2024-01-A1	2024-01	Parameter modification



Contents

1、 General Description.....	1
2、 Block Diagram And Pin Description	2
2.1、 Block Diagram	2
2.2、 Pin Configurations.....	2
2.3、 Pin Description.....	2
2.3、 Function Table.....	3
3、 Electrical Parameter	3
3.1、 Absolute Maximum Ratings.....	3
3.2、 Recommended Operating Conditions.....	3
3.3、 Electrical Characteristics	4
3.3.1、 DC Characteristics 1	4
3.3.2、 DC Characteristics 2.....	5
3.3.3、 AC Characteristics 1	6
3.3.4、 AC Characteristics 2.....	6
4、 Testing Circuit	7
4.1、 AC Testing Circuit	7
4.2、 Test Data	7
4.3、 AC Testing Waveforms.....	8
4.4、 Measurement Points	8
5、 Package Information	9
5.1、 DIP14	9
5.2、 SOP14	10
5.3、 TSSOP14.....	11
6、 Statements And Notes	12



1、General Description

The SN74HC/HCT13 provides two 4-input NAND gates with Schmitt-trigger inputs.

Features:

- Supply voltage range:
SN74HC13: 2~6V
SN74HCT13: 4.5~5.5V
- Input levels:
SN74HC13: CMOS level
SN74HCT13: TTL level
- Temperature range: -40°C to +125°C
- Packaging information: DIP14/SOP14/TSSOP14

Ordering Information:

Tube packing specifications:

Part number	Packaging form	Marking code	Tube quantity	Boxed tube quantity	Boxed quantity	Notes
SN74HC13N(LX)	DIP14	SN74HC13N	25 PCS/tube	40 tube/box	1000 PCS/box	Dimensions of plastic enclosure: 19.0mm×6.4mm Pin spacing: 2.54mm
SN74HCT13N(LX)	DIP14	SN74HCT13N	25 PCS/tube	40 tube/box	1000 PCS/box	Dimensions of plastic enclosure: 19.0mm×6.4mm Pin spacing: 2.54mm

Reel packing specifications:

Part number	Packaging form	Marking code	Reel quantity	Boxed reel quantity	Notes
SN74HC13DR(LX)	SOP14	HC13	2500 PCS/reel	5000 PCS/box	Dimensions of plastic enclosure: 8.7mm×3.9mm Pin spacing: 1.27mm
SN74HCT13DR(LX)	SOP14	HCT13	2500 PCS/reel	5000 PCS/box	Dimensions of plastic enclosure: 8.7mm×3.9mm Pin spacing: 1.27mm
SN74HC13P(LX)	TSSOP14	HC13	5000 PCS/reel	10000 PCS/box	Dimensions of plastic enclosure: 5.0mm×4.4mm Pin spacing: 0.65mm
SN74HCT13P(LX)	TSSOP14	HCT13	5000 PCS/reel	10000 PCS/box	Dimensions of plastic enclosure: 5.0mm×4.4mm Pin spacing: 0.65mm

Note: If the physical information is inconsistent with the ordering information, please refer to the actual product.

2、Block Diagram And Pin Description

2.1、Block Diagram

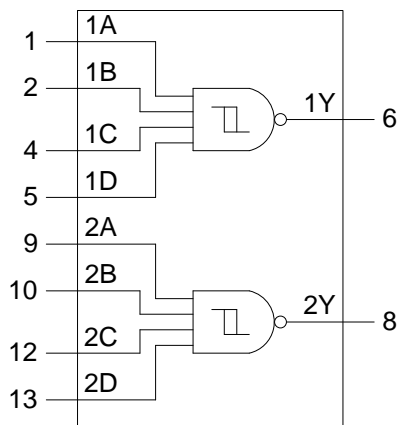

Figure 1. Logic symbol

2.2、Pin Configurations

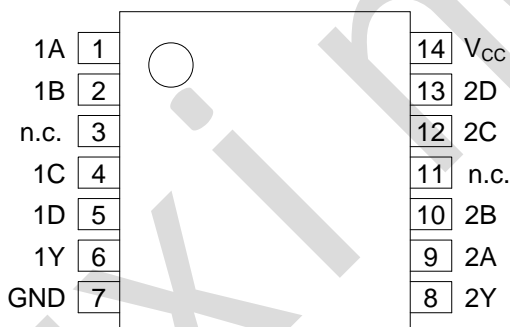

Figure 2. Pin Configurations

2.3、Pin Description

Pin No.	Pin Name	Description
1	1A	data input
2	1B	data input
3	n.c.	not connect
4	1C	data input
5	1D	data input
6	1Y	data output
7	GND	ground (0V)
8	2Y	data output
9	2A	data input
10	2B	data input
11	n.c.	not connect
12	2C	data input
13	2D	data input
14	V _{CC}	supply voltage



2.3、Function Table

Input				Output
nA	nB	nC	nD	nY
L	X	X	X	H
X	L	X	X	H
X	X	L	X	H
X	X	X	L	H
H	H	H	H	L

Note: H=HIGH voltage level; L=LOW voltage level; X=don't care.

3、Electrical Parameter

3.1、Absolute Maximum Ratings

(Voltages are referenced to GND (ground=0V), unless otherwise specified.)

Parameter	Symbol	Conditions	Min.	Max.	Unit
supply voltage	V_{CC}	-	-0.5	+7	V
supply current	I_{CC}	-	-	50	mA
ground current	I_{GND}	-	-50	-	mA
input clamping current	I_{IK}	$V_I < -0.5V$ or $V_I > V_{CC}+0.5V$	-	± 20	mA
output clamping current	I_{OK}	$V_O < -0.5V$ or $V_O > V_{CC}+0.5V$	-	± 20	mA
output current	I_O	$-0.5V < V_O < V_{CC}+0.5V$	-	± 25	mA
storage temperature	T_{stg}	-	-65	+150	$^{\circ}C$
soldering temperature	T_L	10s	DIP		$^{\circ}C$
			SOP/TSSOP		
			245		
			260		

3.2、Recommended Operating Conditions

Parameter	Symbol	Conditions	Min.	Typ.	Max.	Unit
SN74HC13						
supply voltage	V_{CC}	-	2.0	5.0	6.0	V
input voltage	V_I	-	0	-	V_{CC}	V
output voltage	V_O	-	0	-	V_{CC}	V
ambient temperature	T_{amb}	-	-40	-	+125	$^{\circ}C$
SN74HCT13						
supply voltage	V_{CC}	-	4.5	5.0	5.5	V
input voltage	V_I	-	0	-	V_{CC}	V
output voltage	V_O	-	0	-	V_{CC}	V
ambient temperature	T_{amb}	-	-40	-	+125	$^{\circ}C$



3.3、Electrical Characteristics

3.3.1、DC Characteristics 1

($T_{amb} = -40^{\circ}\text{C}$ to $+85^{\circ}\text{C}$, voltages are referenced to GND (ground=0V), unless otherwise specified.)

Parameter	Symbol	V _{CC}	Conditions	Min.	Typ.	Max.	Unit
SN74HC13							
positive-going threshold voltage	V _{T+}	2.0V	-	0.7	1.18	1.5	V
		4.5V	-	1.7	2.38	3.15	V
		6.0V	-	2.1	3.14	4.2	V
negative-going threshold voltage	V _{T-}	2.0V	-	0.3	0.52	0.9	V
		4.5V	-	0.9	1.4	2.0	V
		6.0V	-	1.2	1.89	2.6	V
hysteresis voltage	V _H	2.0V	-	0.2	0.66	1.0	V
		4.5V	-	0.4	0.98	1.4	V
		6.0V	-	0.6	1.25	1.6	V
HIGH-level output voltage	V _{OH}	2.0V	I _O =-20uA	1.9	2.0	-	V
		4.5V	I _O =-20uA	4.4	4.5	-	V
		6.0V	I _O =-20uA	5.9	6.0	-	V
		4.5V	I _O =-4.0mA	3.84	4.32	-	V
		6.0V	I _O =-5.2mA	5.34	5.81	-	V
LOW-level output voltage	V _{OL}	2.0V	I _O =20uA	-	0	0.1	V
		4.5V	I _O =20uA	-	0	0.1	V
		6.0V	I _O =20uA	-	0	0.1	V
		4.5V	I _O =4.0mA	-	0.15	0.33	V
		6.0V	I _O =5.2mA	-	0.16	0.33	V
input leakage current	I _I	6.0V	V _I =V _{CC} or GND	-	-	±1.0	uA
supply current	I _{CC}	6.0V	V _I =V _{CC} or GND; I _O =0A	-	-	20	uA
SN74HCT13							
positive-going threshold voltage	V _{T+}	4.5V	-	1.2	1.41	1.9	V
		5.5V	-	1.4	1.59	2.1	V
negative-going threshold voltage	V _{T-}	4.5V	-	0.5	0.85	1.2	V
		5.5V	-	0.6	0.99	1.4	V
hysteresis voltage	V _H	4.5V	-	0.4	0.56	-	V
		5.5V	-	0.4	0.6	-	V
HIGH-level output voltage	V _{OH}	4.5V	I _O =-20uA	4.4	4.5	-	V
			I _O =-4.0mA	3.84	4.32	-	V
LOW-level output voltage	V _{OL}	4.5V	I _O =20uA	-	0	0.1	V
			I _O =4.0mA	-	0.15	0.33	V
input leakage current	I _I	5.5V	V _I =V _{CC} or GND	-	-	±1.0	uA
supply current	I _{CC}	5.5V	V _I =V _{CC} or GND; I _O =0A	-	-	20	uA
additional supply current	ΔI _{CC}	4.5~5.5V	One input at V _I =V _{CC} -2.1V; Other inputs at V _{CC} or GND; I _O =0A	-	-	135	uA



3.3.2、DC Characteristics 2

($T_{amb} = -40^{\circ}\text{C}$ to $+125^{\circ}\text{C}$, voltages are referenced to GND (ground=0V), unless otherwise specified.)

Parameter	Symbol	V _{CC}	Conditions	Min.	Typ.	Max.	Unit
SN74HC13							
positive-going threshold voltage	V _{T+}	2.0V	-	0.7	-	1.5	V
		4.5V	-	1.7	-	3.15	V
		6.0V	-	2.1	-	4.2	V
negative-going threshold voltage	V _{T-}	2.0V	-	0.3	-	0.9	V
		4.5V	-	0.9	-	2.0	V
		6.0V	-	1.2	-	2.6	V
hysteresis voltage	V _H	2.0V	-	0.2	-	1.0	V
		4.5V	-	0.4	-	1.4	V
		6.0V	-	0.6	-	1.6	V
HIGH-level output voltage	V _{OH}	2.0V	I _O =-20uA	1.9	-	-	V
		4.5V	I _O =-20uA	4.4	-	-	V
		6.0V	I _O =-20uA	5.9	-	-	V
		4.5V	I _O =-4.0mA	3.7	-	-	V
		6.0V	I _O =-5.2mA	5.2	-	-	V
LOW-level output voltage	V _{OL}	2.0V	I _O =20uA	-	-	0.1	V
		4.5V	I _O =20uA	-	-	0.1	V
		6.0V	I _O =20uA	-	-	0.1	V
		4.5V	I _O =4.0mA	-	-	0.4	V
		6.0V	I _O =5.2mA	-	-	0.4	V
input leakage current	I _I	6.0V	V _I =V _{CC} or GND	-	-	±1.0	uA
supply current	I _{CC}	6.0V	V _I =V _{CC} or GND; I _O =0A	-	-	40	uA
SN74HCT13							
positive-going threshold voltage	V _{T+}	4.5V	-	1.2	-	1.9	V
		5.5V	-	1.4	-	2.1	V
negative-going threshold voltage	V _{T-}	4.5V	-	0.5	-	1.2	V
		5.5V	-	0.6	-	1.4	V
hysteresis voltage	V _H	4.5V	-	0.4	-	-	V
		5.5V	-	0.4	-	-	V
HIGH-level output voltage	V _{OH}	4.5V	I _O =-20uA	4.4	-	-	V
			I _O =-4.0mA	3.7	-	-	V
LOW-level output voltage	V _{OL}	4.5V	I _O =20uA	-	-	0.1	V
			I _O =4.0mA	-	-	0.4	V
input leakage current	I _I	5.5V	V _I =V _{CC} or GND	-	-	±1.0	uA
supply current	I _{CC}	5.5V	V _I =V _{CC} or GND; I _O =0A	-	-	40	uA
additional supply current	ΔI _{CC}	4.5~5.5V	One input at V _I =V _{CC} -2.1V; Other inputs at V _{CC} or GND; I _O =0A	-	-	147	uA



3.3.3、AC Characteristics 1

($T_{amb} = -40^{\circ}\text{C}$ to $+85^{\circ}\text{C}$, voltages are referenced to GND (ground=0V), unless otherwise specified.)

Parameter	Symbol	V _{CC}	Conditions	Min.	Typ.	Max.	Unit	
SN74HC13								
propagation delay	t _{PLH} , t _{PHL}	2.0V	C _L =50pF	see Figure 4	-	41	155	ns
		4.5V	C _L =50pF		-	15	31	ns
		5.0V	C _L =15pF		-	12	-	ns
		6.0V	C _L =50pF		-	12	26	ns
transition time	t _{THL} , t _{TLH}	2.0V	C _L =50pF	see Figure 4	-	19	95	ns
		4.5V	C _L =50pF		-	7	19	ns
		6.0V	C _L =50pF		-	6	15	ns
SN74HCT13								
propagation delay	t _{PLH} , t _{PHL}	4.5V	C _L =50pF	see Figure 4	-	20	43	ns
		5.0V	C _L =15pF		-	17	-	ns
transition time	t _{THL} , t _{TLH}	4.5V	C _L =50pF	see Figure 4	-	7	19	ns

3.3.4、AC Characteristics 2

($T_{amb} = -40^{\circ}\text{C}$ to $+125^{\circ}\text{C}$, voltages are referenced to GND (ground=0V), unless otherwise specified.)

Parameter	Symbol	V _{CC}	Conditions	Min.	Typ.	Max.	Unit	
SN74HC13								
propagation delay	t _{PLH} , t _{PHL}	2.0V	C _L =50pF	see Figure 4	-	-	190	ns
		4.5V	C _L =50pF		-	-	38	ns
		6.0V	C _L =50pF		-	-	32	ns
transition time	t _{THL} , t _{TLH}	2.0V	C _L =50pF	see Figure 4	-	-	110	ns
		4.5V	C _L =50pF		-	-	22	ns
		6.0V	C _L =50pF		-	-	19	ns
SN74HCT13								
propagation delay	t _{PLH} , t _{PHL}	4.5V	C _L =50pF	see Figure 4	-	-	51	ns
transition time	t _{THL} , t _{TLH}	4.5V	C _L =50pF	see Figure 4	-	-	22	ns

4、Testing Circuit

4.1、AC Testing Circuit

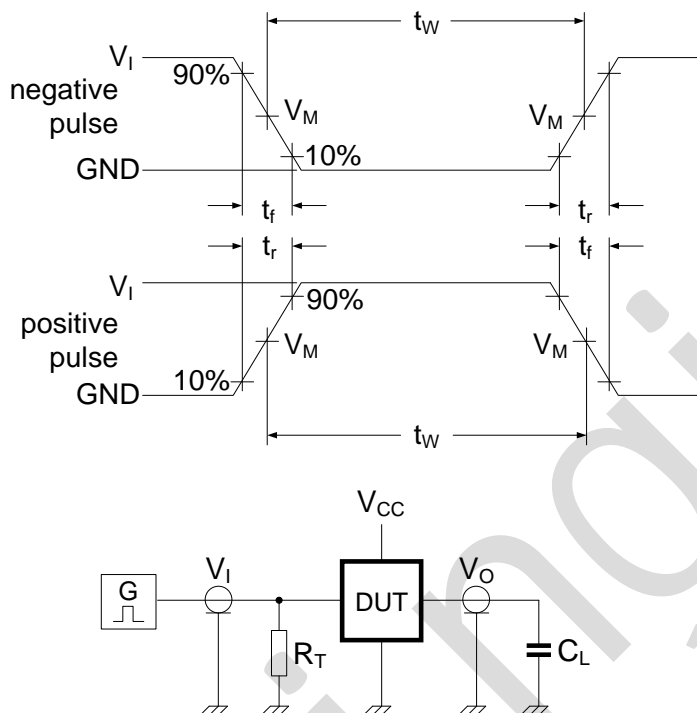

Figure 3. Test circuit for measuring switching times

C_L includes probe and jig capacitance.

4.2、Test Data

Type	Input		Load	Test
	V_I	$t_r = t_f$	C_L	
SN74HC13	V_{CC}	6.0ns	15pF, 50pF	t_{PLH}/t_{PHL}
SN74HCT13	3.0V	6.0ns	15pF, 50pF	t_{PLH}/t_{PHL}

4.3、AC Testing Waveforms

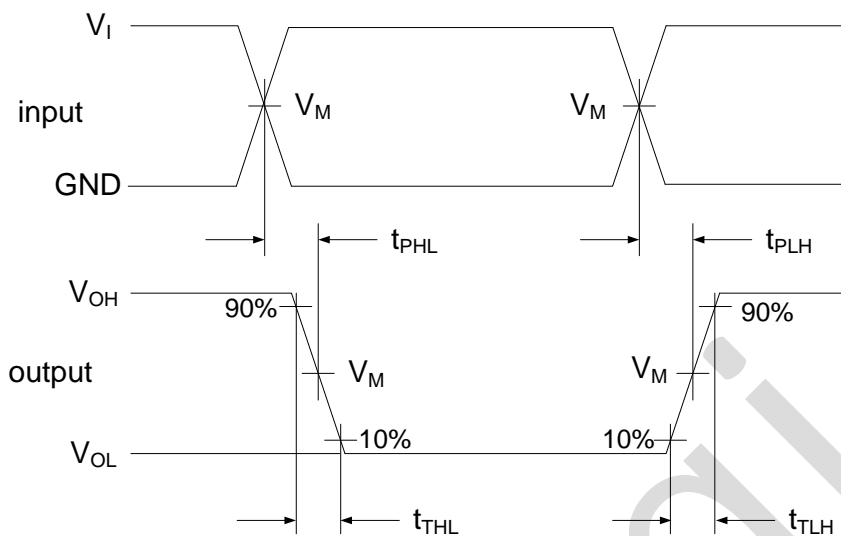

Figure 4. Propagation delay, output transition time

4.4、Measurement Points

Type	Input	Output		
	V_M	V_M	V_X	V_Y
SN74HC13	$0.5 \times V_{CC}$	$0.5 \times V_{CC}$	$0.1 \times V_{CC}$	$0.9 \times V_{CC}$
SN74HCT13	1.3V	1.3V	$0.1 \times V_{CC}$	$0.9 \times V_{CC}$



5、Package Information

5.1、DIP14

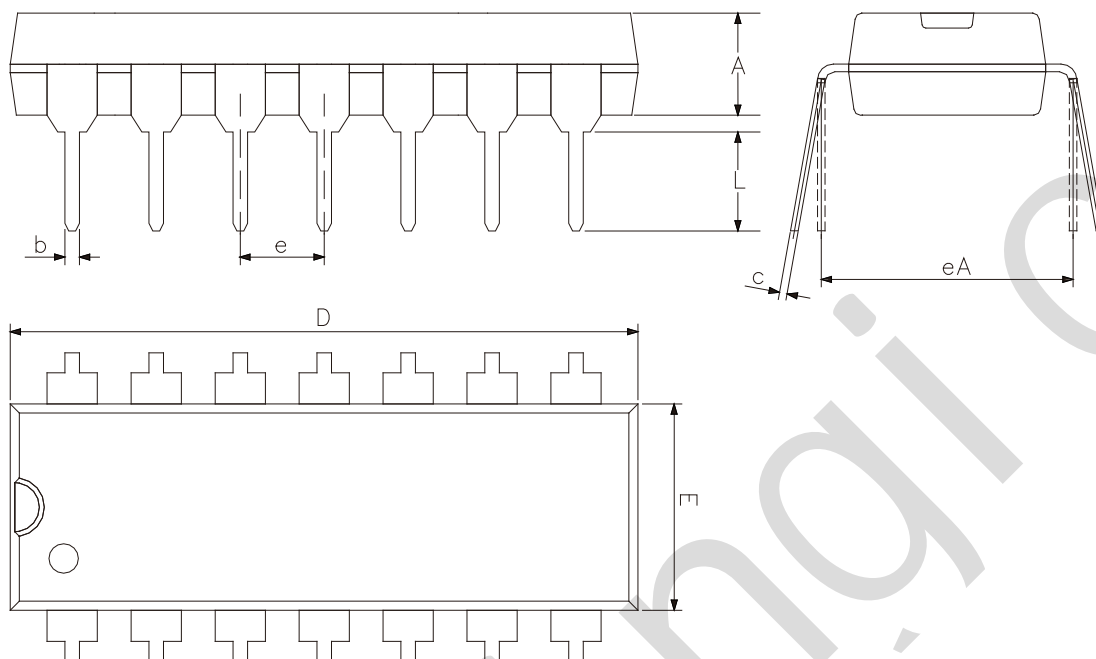

2023/12/A	Dimensions In Millimeters		
	Symbol	Min	Max
	A	3.05	3.60
	b	0.33	0.56
	c	0.20	0.36
	D	18.80	19.40
	E	6.20	6.60
	e	2.54	
	eA	7.62	10.90
	L	2.92	—

5.2、SOP14

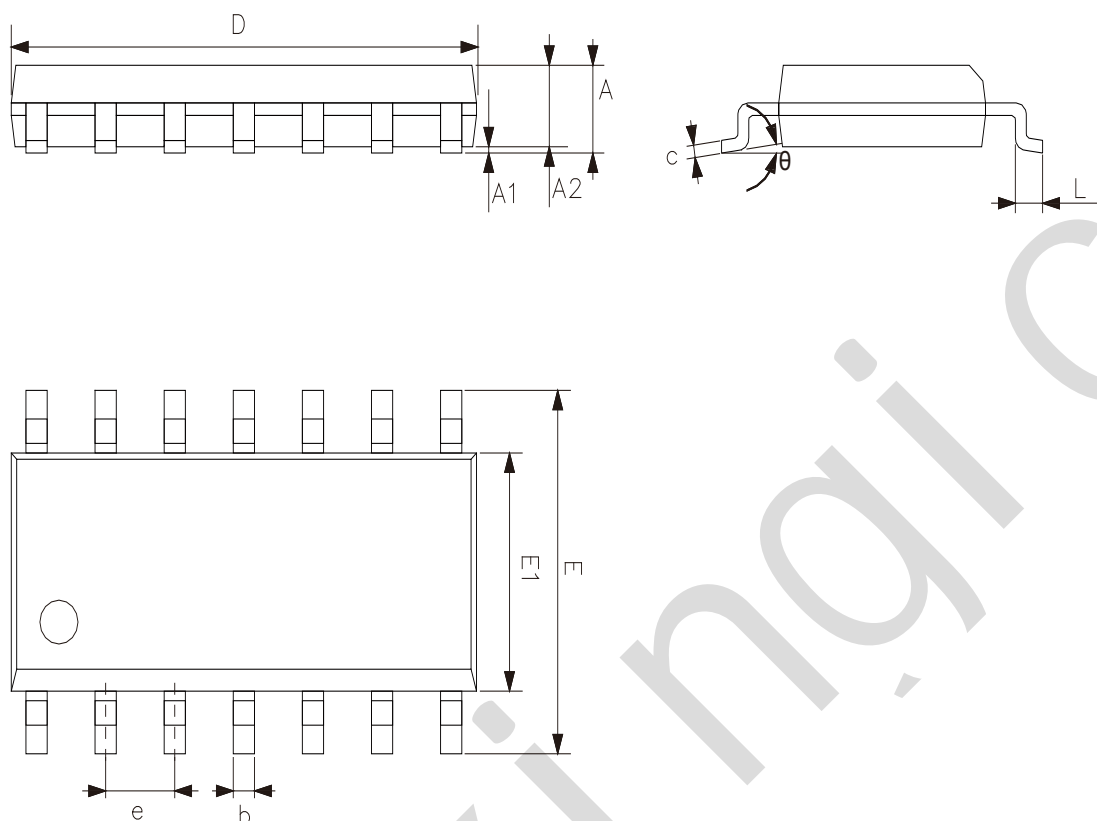

2023/12/A	Dimensions In Millimeters	
Symbol	Min.	Max.
A	1.50	1.75
A1	0.05	0.25
A2	1.30	—
b	0.33	0.50
c	0.19	0.25
D	8.43	8.76
E	5.80	6.25
E1	3.75	4.00
e	1.27	
L	0.40	0.89
θ	0°	8°

5.3、TSSOP14

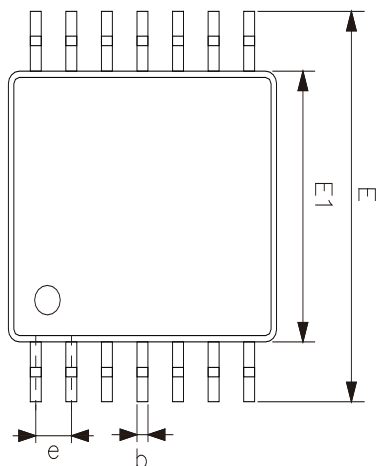
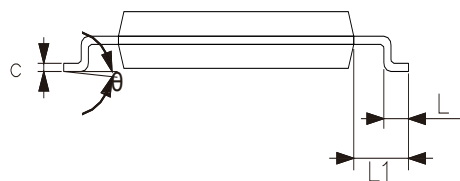
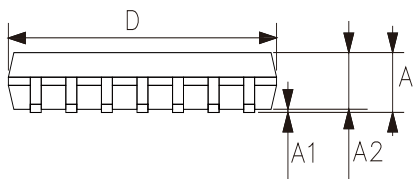

2023/12/A	Dimensions In Millimeters	
Symbol	Min	Max
A	—	1.20
A1	0.05	0.15
A2	0.80	1.05
b	0.19	0.30
c	0.09	0.20
D	4.90	5.10
E1	4.30	4.50
E	6.20	6.60
e	0.65	
L	0.45	0.75
L1	1.00	
θ	0°	8°



6、Statements And Notes

Recommended carefully reading this information before the use of this product;

The information in this document are subject to change without notice;

This information is using to the reference only, the company is not responsible for any loss;

The company is not responsible for the any infringement of the third party patents or other rights of the responsibility.

Lingxingmicro.com

X-ON Electronics

Largest Supplier of Electrical and Electronic Components

Click to view similar products for [Logic Gates](#) category:

Click to view products by [lingxingic](#) manufacturer:

Other Similar products are found below :

[74HC85N](#) [NL17SG32DFT2G](#) [CD4068BE](#) [NL17SG86DFT2G](#) [NLX1G11AMUTCG](#) [NLX1G97MUTCG](#) [74LS38](#) [74LVC1G08Z-7](#)
[CD4025BE](#) [NLV17SZ00DFT2G](#) [NLV17SZ126DFT2G](#) [NLV27WZ17DFT2G](#) [NLV74HC02ADR2G](#) [74HC32S14-13](#) [74LS133](#)
[74LVC1G32Z-7](#) [74LVC1G86Z-7](#) [NLV74HC14ADR2G](#) [NLV74HC20ADR2G](#) [NLVVHC1G09DFT1G](#) [NLX2G86MUTCG](#)
[74LVC2G32RA3-7](#) [74LVC2G00HD4-7](#) [NL17SG02P5T5G](#) [74LVC2G86HK3-7](#) [NLVVHC1G14DFT2G](#) [NLX1G99DMUTWG](#)
[NLVVHC1G00DFT2G](#) [NLV7SZ57DFT2G](#) [NLV74VHC04DTR2G](#) [NLV27WZ00USG](#) [NLU1G86CMUTCG](#) [NLU1G08CMUTCG](#)
[NL17SZ32P5T5G](#) [NL17SZ00P5T5G](#) [NL17SH02P5T5G](#) [74AUP2G00RA3-7](#) [NLVVHC1GT00DFT2G](#) [NLV74HC02ADTR2G](#)
[NLX1G332CMUTCG](#) [NLVHCT132ADTR2G](#) [NL17SG86P5T5G](#) [NL17SZ05P5T5G](#) [NLV74VHC00DTR2G](#) [NLVVHC1G02DFT1G](#)
[NLV74HC86ADR2G](#) [74LVC2G32HK3-7](#) [74LVC2G86RA3-7](#) [NL17SZ38DBVT1G](#) [NLV18SZ00DFT2G](#)