



SN74HC/HCT157 (LX) Quad 2-input Multiplexer

Product Specification

Specification Revision History:

Version	Date	Description
2021-11-A2	2021-11	Modify Ordering Information; Modify ambient temperature to -40°C ~ $+125^{\circ}\text{C}$.
2021-12-A3	2021-12	Modify Ordering Information



1、General Description

The SN74HC/HCT157 are quad 2-input multiplexers which select 4 bits of data from two sources under the control of a common data select input (S). The enable input (\bar{E}) is active LOW. When \bar{E} is HIGH, all of the outputs (1Y to 4Y) are forced LOW regardless of all other input conditions.

Moving the data from two groups of registers to four common output buses is a common use of the SN74HC/HCT157. The state of the common data select input (S) determines the particular register from which the data comes. It can also be used as function generator. The device is useful for implementing highly irregular logic by generating any four of the 16 different functions of two variables with one variable common. The SN74HC/HCT157 is logic implementation of a 4-pole, 2-position switch, where the position of the switch is determined by the logic levels applied to S.

The logic equations are:

$$1Y = \bar{E} \times (1I1 \times S + 1I0 \times \bar{S})$$

$$2Y = \bar{E} \times (2I1 \times S + 2I0 \times \bar{S})$$

$$3Y = \bar{E} \times (3I1 \times S + 3I0 \times \bar{S})$$

$$4Y = \bar{E} \times (4I1 \times S + 4I0 \times \bar{S})$$

The SN74HC/HCT157 is identical to the SN74HC/HCT158 but has non-inverting (true) outputs.

Features:

- Input levels:
 - For SN74HC157: CMOS level
 - For SN74HCT157: TTL level
- Low-power dissipation
- Non-inverting data path
- Specified from -40°C to +125°C
- Packaging information: DIP16/SOP16/TSSOP16



深圳市灵星芯微电子科技有限公司

Shenzhen Lingxing Microelectronics Technology Co., Ltd.

版次: B1

编号: SN74HC/HCT157-LX-A157

Ordering Information:

Tube packing specifications:

Part number	Packaging form	Marking code	Tube quantity	Boxed tube quantity	Boxed quantity	Notes
SN74HC157N (LX)	DIP16	SN74HC157N	25 PCS/tube	40 tube/box	1000 PCS/box	Dimensions of plastic enclosure: 19.0mm×6.4mm Pin spacing: 2.54mm
SN74HCT157N (LX)	DIP16	SN74HCT157N	25 PCS/tube	40 tube/box	1000 PCS/box	Dimensions of plastic enclosure: 19.0mm×6.4mm Pin spacing: 2.54mm



Reel packing specifications:

Part number	Packaging form	Markingcode	Reel quantity	Boxed reel quantity	Notes
SN74HC157DR (LX)	SOP16	HC157	2500 PCS/reel	5000 PCS/box	Dimensions of plastic enclosure: 10.0mm×3.9mm Pin spacing:1.27mm
SN74HCT157DR (LX)	SOP16	HCT157	4000 PCS/reel	8000 PCS/box	Dimensions of plastic enclosure: 10.0mm×3.9mm Pin spacing:1.27mm
SN74HC157PWR (LX)	TSSOP16	74HC157	5000 PCS/reel	10000 PCS/box	Dimensions of plastic enclosure: 5.0mm×4.4mm Pin spacing:0.65mm
SN74HCT157PWR (LX)	TSSOP16	74HCT157	5000 PCS/reel	10000 PCS/box	Dimensions of plastic enclosure: 5.0mm×4.4mm Pin spacing:0.65mm

Note: If the physical information is inconsistent with the ordering information, please refer to the actual product.



2、Block Diagram And Pin Description

2.1、Block Diagram

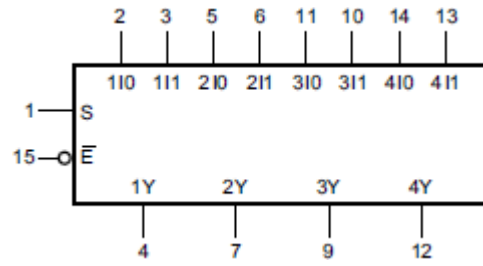

Figure 1. Logic symbol

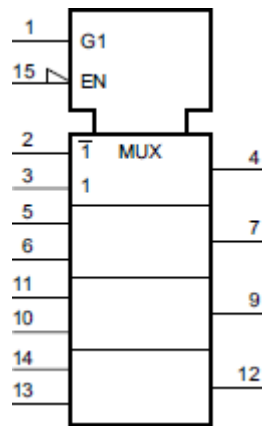

Figure 2. IEC logic symbol

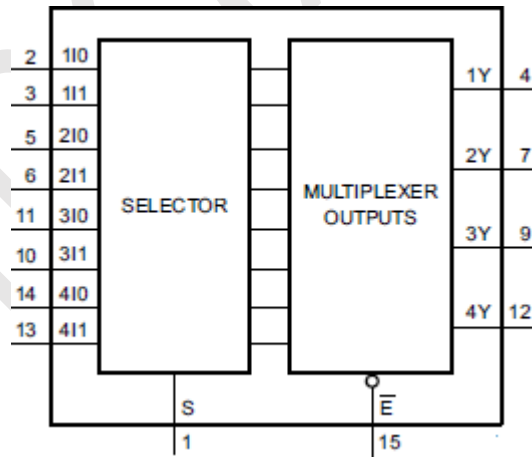

Figure 3. Functional diagram

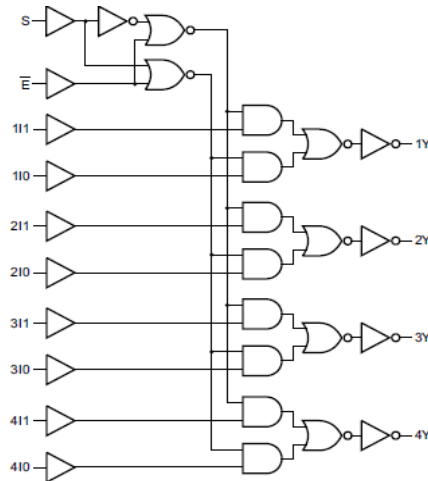
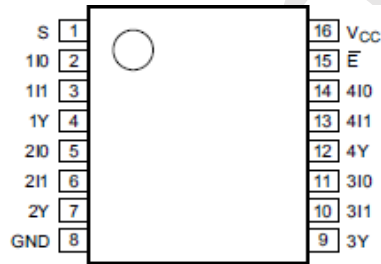

Figure 4. Logic diagram

2.2 、 Pin Configurations



2.3 、 Pin Description

Pin No.	Pin Name	Description
1	S	common data select input
2	1I0	data input from source 0
3	1I1	data input from source 1
4	1Y	multiplexer output
5	2I0	data input from source 0
6	2I1	data input from source 1
7	2Y	multiplexer output
8	GND	ground (0V)
9	3Y	multiplexer output
10	3I1	data input from source 1
11	3I0	data input from source 0
12	4Y	multiplexer output
13	4I1	data input from source 1
14	4I0	data input from source 0
15	E	enable input (active LOW)
16	V _{CC}	supply voltage



2.4、Function Table

Input				Output
\bar{E}	S	nI0	nI1	nY
H	X	X	X	L
L	L	L	X	L
L	L	H	X	H
L	H	X	L	L
L	H	X	H	H

Note: H=HIGH voltage level; L=LOW voltage level; X=don't care.

3、Electrical Parameter

3.1、Absolute Maximum Ratings

(Voltages are referenced to GND (ground=0V), unless otherwise specified.)

Parameter	Symbol	Conditions	Min.	Max.	Unit
supply voltage	V_{CC}	-	-0.5	+7.0	V
input clamping current	I_{IK}	$V_I < -0.5V$ or $V_I > V_{CC}+0.5V$	-	± 20	mA
output clamping current	I_{OK}	$V_O < -0.5V$ or $V_O > V_{CC}+0.5V$	-	± 20	mA
output current	I_O	$V_O = -0.5V$ to $(V_{CC}+0.5V)$	-	± 25	mA
supply current	I_{CC}	-	-	+50	mA
ground current	I_{GND}	-	-50	-	mA
storage temperature	T_{stg}	-	-65	+150	$^{\circ}C$
total power dissipation	P_{tot}	-	-	500	mW
soldering temperature	T_L	10s	DIP	245	$^{\circ}C$
			SOP	250	$^{\circ}C$

Note:

- [1] For DIP16 packages: above $70^{\circ}C$ the value of P_{tot} derates linearly with 12mW/K.
- [2] For SOP16 packages: above $70^{\circ}C$ the value of P_{tot} derates linearly with 8mW/K.
- [3] For (T)SSOP16 packages: above $60^{\circ}C$ the value of P_{tot} derates linearly with 5.5mW/K.



3.2、Recommended Operating Conditions

Parameter	Symbol	Conditions	Min.	Typ.	Max.	Unit
SN74HC157						
supply voltage	V_{CC}	-	2.0	5.0	6.0	V
input voltage	V_I	-	0	-	V_{CC}	V
output voltage	V_O	-	0	-	V_{CC}	V
input transition rise and fall rate	$\Delta t/\Delta V$	$V_{CC}=2.0V$	-	-	625	ns/V
		$V_{CC}=4.5V$	-	1.67	139	ns/V
		$V_{CC}=6.0V$	-	-	83	ns/V
ambient temperature	T_{amb}	-	-40	-	+105	°C
SN74HCT157						
supply voltage	V_{CC}	-	4.5	5.0	5.5	V
input voltage	V_I	-	0	-	V_{CC}	V
output voltage	V_O	-	0	-	V_{CC}	V
input transition rise and fall rate	$\Delta t/\Delta V$	$V_{CC}=4.5V$	-	1.67	139	ns/V
ambient temperature	T_{amb}	-	-40	-	+105	°C

3.3、Electrical Characteristics

3.3.1、DC Characteristics 1

($T_{amb}=25^{\circ}C$, voltages are referenced to GND (ground=0V), unless otherwise specified.)

Parameter	Symbol	Conditions	Min.	Typ.	Max.	Unit	
SN74HC157							
HIGH-level input voltage	V_{IH}	$V_{CC}=2.0V$	1.5	1.2	-	V	
		$V_{CC}=4.5V$	3.15	2.4	-	V	
		$V_{CC}=6.0V$	4.2	3.2	-	V	
LOW-level input voltage	V_{IL}	$V_{CC}=2.0V$	-	0.8	0.5	V	
		$V_{CC}=4.5V$	-	2.1	1.35	V	
		$V_{CC}=6.0V$	-	2.8	1.8	V	
HIGH-level output voltage	V_{OH}	$V_I=V_{IH}$ or V_{IL}	$I_O=-20\mu A; V_{CC}=2.0V$	1.9	2.0	-	V
			$I_O=-20\mu A; V_{CC}=4.5V$	4.4	4.5	-	V
			$I_O=-20\mu A; V_{CC}=6.0V$	5.9	6.0	-	V
			$I_O=-4.0mA; V_{CC}=4.5V$	3.98	4.32	-	V
			$I_O=-5.2mA; V_{CC}=6.0V$	5.48	5.81	-	V
LOW-level output voltage	V_{OL}	$V_I=V_{IH}$ or V_{IL}	$I_O=20\mu A; V_{CC}=2.0V$	-	0	0.1	V
			$I_O=20\mu A; V_{CC}=4.5V$	-	0	0.1	V
			$I_O=20\mu A; V_{CC}=6.0V$	-	0	0.1	V
			$I_O=4.0mA; V_{CC}=4.5V$	-	0.15	0.26	V
			$I_O=5.2mA; V_{CC}=6.0V$	-	0.16	0.26	V
input leakage current	I_I	$V_I=V_{CC}$ or GND; $V_{CC}=6.0V$	-	-	± 0.1	μA	
supply current	I_{CC}	$V_I=V_{CC}$ or GND; $I_O=0A; V_{CC}=6.0V$	-	-	8.0	μA	
input capacitance	C_I	-	-	3.5	-	pF	



深圳市灵星芯微电子科技有限公司

Shenzhen Lingxing Microelectronics Technology Co., Ltd.

版次: B1

编号: SN74HC/HCT157-LX-A157

SN74HCT157							
HIGH-level input voltage	V_{IH}	$V_{CC}=4.5V$ to $5.5V$		2.0	1.6	-	V
LOW-level input voltage	V_{IL}	$V_{CC}=4.5V$ to $5.5V$		-	1.2	0.8	V
HIGH-level output voltage	V_{OH}	$V_I=V_{IH}$ or V_{IL} ; $V_{CC}=4.5V$	$I_O=-20\mu A$	4.4	4.5	-	V
			$I_O=-4.0mA$	3.98	4.32	-	V
LOW-level output voltage	V_{OL}	$V_I=V_{IH}$ or V_{IL} ; $V_{CC}=4.5V$	$I_O=20\mu A$	-	0	0.1	V
			$I_O=4.0mA$	-	0.15	0.26	V
input leakage current	I_I	$V_I=V_{CC}$ or GND; $V_{CC}=5.5V$		-	-	± 0.1	μA
supply current	I_{CC}	$V_I=V_{CC}$ or GND; $I_O=0A$; $V_{CC}=5.5V$		-	-	8.0	μA
additional supply current	ΔI_{CC}	$V_I=V_{CC}-2.1V$; other inputs at V_{CC} or GND; $I_O=0A$; $V_{CC}=4.5V$ to $5.5V$	per input pin; nI0, nI1 inputs	-	100	360	μA
			per input pin; E input	-	60	216	μA
			per input pin; S input	-	100	360	μA
input capacitance	C_I	-		-	3.5	-	pF

3.3.2 、 DC Characteristics 2

($T_{amb}=-40^{\circ}C$ to $+85^{\circ}C$, voltages are referenced to GND (ground=0V), unless otherwise specified.)

Parameter	Symbol	Conditions	Min.	Typ.	Max.	Unit	
SN74HC157							
HIGH-level input voltage	V_{IH}	$V_{CC}=2.0V$	1.5	-	-	V	
		$V_{CC}=4.5V$	3.15	-	-	V	
		$V_{CC}=6.0V$	4.2	-	-	V	
LOW-level input voltage	V_{IL}	$V_{CC}=2.0V$	-	-	0.5	V	
		$V_{CC}=4.5V$	-	-	1.35	V	
		$V_{CC}=6.0V$	-	-	1.8	V	
HIGH-level output voltage	V_{OH}	$V_I=V_{IH}$ or V_{IL}	$I_O=-20\mu A$; $V_{CC}=2.0V$	1.9	-	-	V
			$I_O=-20\mu A$; $V_{CC}=4.5V$	4.4	-	-	V
			$I_O=-20\mu A$; $V_{CC}=6.0V$	5.9	-	-	V
			$I_O=-4.0mA$; $V_{CC}=4.5V$	3.84	-	-	V
			$I_O=-5.2mA$; $V_{CC}=6.0V$	5.34	-	-	V
LOW-level output voltage	V_{OL}	$V_I=V_{IH}$ or V_{IL}	$I_O=20\mu A$; $V_{CC}=2.0V$	-	-	0.1	V
			$I_O=20\mu A$; $V_{CC}=4.5V$	-	-	0.1	V
			$I_O=20\mu A$; $V_{CC}=6.0V$	-	-	0.1	V
			$I_O=4.0mA$; $V_{CC}=4.5V$	-	-	0.33	V
			$I_O=5.2mA$; $V_{CC}=6.0V$	-	-	0.33	V
input leakage current	I_I	$V_I=V_{CC}$ or GND; $V_{CC}=6.0V$	-	-	± 1.0	μA	
supply current	I_{CC}	$V_I=V_{CC}$ or GND; $I_O=0A$; $V_{CC}=6.0V$	-	-	80	μA	
SN74HCT157							



深圳市灵星芯微电子科技有限公司

Shenzhen Lingxing Microelectronics Technology Co., Ltd.

版次: B1

编号: SN74HC/HCT157-LX-A157

HIGH-level input voltage	V_{IH}	$V_{CC}=4.5V$ to $5.5V$	2.0	-	-	V	
LOW-level input voltage	V_{IL}	$V_{CC}=4.5V$ to $5.5V$	-	-	0.8	V	
HIGH-level output voltage	V_{OH}	$V_I=V_{IH}$ or V_{IL} ; $V_{CC}=4.5V$	$I_O=-20\mu A$	4.4	-	-	V
			$I_O=-4.0mA$	3.84	-	-	V
LOW-level output voltage	V_{OL}	$V_I=V_{IH}$ or V_{IL} ; $V_{CC}=4.5V$	$I_O=20\mu A$	-	-	0.1	V
			$I_O=4.0mA$	-	-	0.33	V
input leakage current	I_I	$V_I=V_{CC}$ or GND; $V_{CC}=5.5V$	-	-	± 1.0	μA	
supply current	I_{CC}	$V_I=V_{CC}$ or GND; $I_O=0A$; $V_{CC}=5.5V$	-	-	80	μA	
additional supply current	ΔI_{CC}	$V_I=V_{CC}-2.1V$; other inputs at V_{CC} or GND; $I_O=0A$; $V_{CC}=4.5V$ to $5.5V$	per input pin; n10, n11 inputs	-	-	450	μA
			per input pin; \bar{E} input	-	-	270	μA
			per input pin; S input	-	-	450	μA

3.3.3 、 DC Characteristics 3

($T_{amb}=-40^{\circ}C$ to $+105^{\circ}C$, voltages are referenced to GND (ground=0V), unless otherwise specified.)

Parameter	Symbol	Conditions	Min.	Typ.	Max.	Unit	
SN74HC157							
HIGH-level input voltage	V_{IH}	$V_{CC}=2.0V$	1.5	-	-	V	
		$V_{CC}=4.5V$	3.15	-	-	V	
		$V_{CC}=6.0V$	4.2	-	-	V	
LOW-level input voltage	V_{IL}	$V_{CC}=2.0V$	-	-	0.5	V	
		$V_{CC}=4.5V$	-	-	1.35	V	
		$V_{CC}=6.0V$	-	-	1.8	V	
HIGH-level output voltage	V_{OH}	$V_I=V_{IH}$ or V_{IL}	$I_O=-20\mu A$; $V_{CC}=2.0V$	1.9	-	-	V
			$I_O=-20\mu A$; $V_{CC}=4.5V$	4.4	-	-	V
			$I_O=-20\mu A$; $V_{CC}=6.0V$	5.9	-	-	V
			$I_O=-4.0mA$; $V_{CC}=4.5V$	3.7	-	-	V
			$I_O=-5.2mA$; $V_{CC}=6.0V$	5.2	-	-	V
LOW-level output voltage	V_{OL}	$V_I=V_{IH}$ or V_{IL}	$I_O=20\mu A$; $V_{CC}=2.0V$	-	-	0.1	V
			$I_O=20\mu A$; $V_{CC}=4.5V$	-	-	0.1	V
			$I_O=20\mu A$; $V_{CC}=6.0V$	-	-	0.1	V
			$I_O=4.0mA$; $V_{CC}=4.5V$	-	-	0.4	V
			$I_O=5.2mA$; $V_{CC}=6.0V$	-	-	0.4	V
input leakage current	I_I	$V_I=V_{CC}$ or GND; $V_{CC}=6.0V$	-	-	± 1.0	μA	
supply current	I_{CC}	$V_I=V_{CC}$ or GND; $I_O=0A$; $V_{CC}=6.0V$	-	-	160	μA	
SN74HCT157							
HIGH-level input voltage	V_{IH}	$V_{CC}=4.5V$ to $5.5V$	2.0	-	-	V	
LOW-level input voltage	V_{IL}	$V_{CC}=4.5V$ to $5.5V$	-	-	0.8	V	



深圳市灵星芯微电子科技有限公司

Shenzhen Lingxing Microelectronics Technology Co., Ltd.

版次: B1

编号: SN74HC/HCT157-LX-A157

HIGH-level output voltage	V_{OH}	$V_I=V_{IH}$ or V_{IL} ; $V_{CC}=4.5V$	$I_O=-20\mu A$	4.4	-	-	V
			$I_O=-4.0mA$	3.7	-	-	V
LOW-level output voltage	V_{OL}	$V_I=V_{IH}$ or V_{IL} ; $V_{CC}=4.5V$	$I_O=20\mu A$	-	-	0.1	V
			$I_O=4.0mA$	-	-	0.4	V
input leakage	I_I	$V_I=V_{CC}$ or GND; $V_{CC}=5.5V$		-	-	± 1.0	μA
current							
supply current	I_{CC}	$V_I=V_{CC}$ or GND; $I_O=0A$; $V_{CC}=5.5V$		-	-	160	μA
additional supply current	ΔI_{CC}	$V_I=V_{CC}-2.1V$; other inputs at V_{CC} or GND; $I_O=0A$; $V_{CC}=4.5V$ to $5.5V$	per input pin; nI0, nI1 inputs	-	-	490	μA
			per input pin; E input	-	-	294	μA
			per input pin; S input	-	-	490	μA

3.3.4 、 AC Characteristics 1

($T_{amb}=25^{\circ}C$, GND =0V, $C_L=50pF$, unless otherwise specified.)

Parameter	Symbol	Conditions	Min.	Typ.	Max.	Unit	
SN74HC157							
propagation delay	t_{pd}	nI0, nI1 to nY; see Figure 6 ^[1]	$V_{CC}=2.0V$	-	36	125	ns
			$V_{CC}=4.5V$	-	13	25	ns
			$V_{CC}=5.0V$; $C_L=15pF$	-	11	-	ns
			$V_{CC}=6.0V$	-	10	21	ns
		S to nY; see Figure 6 ^[1]	$V_{CC}=2.0V$	-	41	125	ns
			$V_{CC}=4.5V$	-	15	25	ns
			$V_{CC}=5.0V$; $C_L=15pF$	-	12	-	ns
			$V_{CC}=6.0V$	-	12	21	ns
		E to nY; see Figure 7 ^[1]	$V_{CC}=2.0V$	-	39	115	ns
			$V_{CC}=4.5V$	-	14	23	ns
			$V_{CC}=5.0V$; $C_L=15pF$	-	11	-	ns
			$V_{CC}=6.0V$	-	11	20	ns
transition time	t_t	nY; see Figure 6 ^[2]	$V_{CC}=2.0V$	-	19	75	ns
			$V_{CC}=4.5V$	-	7	15	ns
			$V_{CC}=6.0V$	-	6	13	ns
power dissipation capacitance	C_{PD}	$C_L=50pF$; $f=1MHz$; $V_I=GND$ to V_{CC} ^[3]	-	70	-	pF	
SN74HCT157							
propagation delay	t_{pd}	nI0, nI1 to nY; see Figure 6 ^[1]	$V_{CC}=4.5V$	-	16	27	ns
			$V_{CC}=5.0V$; $C_L=15pF$	-	13	-	ns
		S to nY; see Figure 6 ^[1]	$V_{CC}=4.5V$	-	22	37	ns
			$V_{CC}=5.0V$; $C_L=15pF$	-	19	-	ns
		E to nY; see Figure 7 ^[1]	$V_{CC}=4.5V$	-	15	26	ns
		$V_{CC}=5.0V$; $C_L=15pF$	-	12	-	ns	
transition time	t_t	nY; $V_{CC}=4.5V$; see Figure 6 ^[2]	-	7	15	ns	



power dissipation capacitance	C_{PD}	$C_L=50\text{pF}; f=1\text{MHz}; V_I=\text{GND to } V_{CC}-1.5\text{V}^{[3]}$	-	70	-	pF
-------------------------------	----------	---	---	----	---	----

Note:

[1] t_{pd} is the same as t_{PLH} and t_{PHL} .

[2] t_t is the same as t_{THL} and t_{TLH} .

[3] C_{PD} is used to determine the dynamic power dissipation (P_D in uW).

$$P_D = C_{PD} \times V_{CC}^2 \times f_i \times N + \sum (C_L \times V_{CC}^2 \times f_o) \text{ where:}$$

f_i =input frequency in MHz;

f_o =output frequency in MHz;

C_L =output load capacitance in pF;

V_{CC} =supply voltage in V;

N =number of inputs switching;

$\sum (C_L \times V_{CC}^2 \times f_o)$ =sum of outputs.

3.3.5 、 AC Characteristics 2

($T_{amb}=-40^\circ\text{C}$ to $+85^\circ\text{C}$, $\text{GND}=0\text{V}$, $C_L=50\text{pF}$, unless otherwise specified.)

Parameter	Symbol	Conditions	Min.	Typ.	Max.	Unit	
SN74HC157							
propagation delay	t_{pd}	nI0, nI1 to nY; see Figure 6 ^[1]	$V_{CC}=2.0\text{V}$	-	-	155	ns
			$V_{CC}=4.5\text{V}$	-	-	31	ns
			$V_{CC}=6.0\text{V}$	-	-	26	ns
		S to nY; see Figure 6 ^[1]	$V_{CC}=2.0\text{V}$	-	-	155	ns
			$V_{CC}=4.5\text{V}$	-	-	31	ns
			$V_{CC}=6.0\text{V}$	-	-	26	ns
		E to nY; see Figure 7 ^[1]	$V_{CC}=2.0\text{V}$	-	-	145	ns
			$V_{CC}=4.5\text{V}$	-	-	29	ns
			$V_{CC}=6.0\text{V}$	-	-	25	ns
transition time	t_t	nY; see Figure 6 ^[2]	$V_{CC}=2.0\text{V}$	-	-	95	ns
			$V_{CC}=4.5\text{V}$	-	-	19	ns
			$V_{CC}=6.0\text{V}$	-	-	16	ns
SN74HCT157							
propagation delay	t_{pd}	nI0, nI1 to nY; see Figure 6 ^[1]	$V_{CC}=4.5\text{V}$	-	-	34	ns
		S to nY; see Figure 6 ^[1]	$V_{CC}=4.5\text{V}$	-	-	46	ns
		E to nY; see Figure 7 ^[1]	$V_{CC}=4.5\text{V}$	-	-	33	ns
transition time	t_t	nY; $V_{CC}=4.5\text{V}$; see Figure 6 ^[2]	-	-	19	ns	

Note:

[1] t_{pd} is the same as t_{PLH} and t_{PHL} .

[2] t_t is the same as t_{THL} and t_{TLH} .



3.3.6 、 AC Characteristics 3

($T_{amb}=-40^{\circ}C$ to $+105^{\circ}C$, $GND=0V$, $C_L=50pF$, unless otherwise specified.)

Parameter	Symbol	Conditions	Min.	Typ.	Max.	Unit	
SN74HC157							
propagation delay	t_{pd}	nI0, nI1 to nY; see Figure 6 ^[1]	$V_{CC}=2.0V$	-	-	190	ns
			$V_{CC}=4.5V$	-	-	38	ns
			$V_{CC}=6.0V$	-	-	32	ns
		S to nY; see Figure 6 ^[1]	$V_{CC}=2.0V$	-	-	190	ns
			$V_{CC}=4.5V$	-	-	38	ns
			$V_{CC}=6.0V$	-	-	32	ns
		E to nY; see Figure 7 ^[1]	$V_{CC}=2.0V$	-	-	175	ns
			$V_{CC}=4.5V$	-	-	35	ns
			$V_{CC}=6.0V$	-	-	30	ns
transition time	t_t	nY; see Figure 6 ^[2]	$V_{CC}=2.0V$	-	-	110	ns
			$V_{CC}=4.5V$	-	-	22	ns
			$V_{CC}=6.0V$	-	-	19	ns
SN74HCT157							
propagation delay	t_{pd}	nI0, nI1 to nY; see Figure 6 ^[1]	$V_{CC}=4.5V$	-	-	41	ns
		S to nY; see Figure 6 ^[1]	$V_{CC}=4.5V$	-	-	56	ns
		E to nY; see Figure 7 ^[1]	$V_{CC}=4.5V$	-	-	39	ns
transition time	t_t	nY; $V_{CC}=4.5V$; see Figure 6 ^[2]	-	-	22	ns	

Note:

[1] t_{pd} is the same as t_{PLH} and t_{PHL} .

[2] t_t is the same as t_{THL} and t_{TLH} .

4、Testing Circuit

4.1、AC Testing Circuit

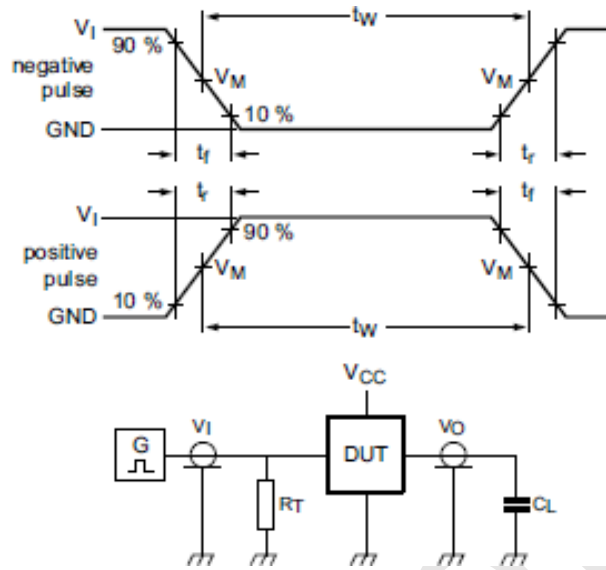

Figure 5. Test circuit for measuring switching times

Definitions for test circuit:

C_L =Load capacitance including jig and probe capacitance.

R_T =Termination resistance should be equal to the output impedance Z_o of the pulse generator.

4.2、AC Testing Waveforms

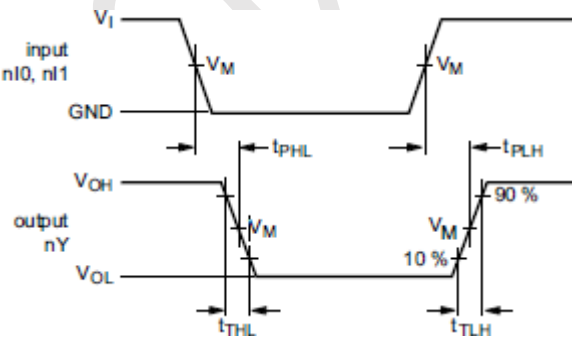

Figure 6. Propagation delay input (nI0, nI1, S) to output (nYn)

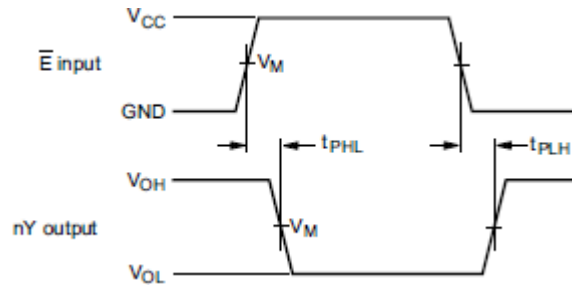

Figure 7. Propagation delay input (\bar{E}) to output (nY)

4.3 、 Measurement Points

Type	Input	Output
	V_M	V_M
SN74HC157	$0.5 \times V_{CC}$	$0.5 \times V_{CC}$
SN74HCT157	1.3V	1.3V

4.4 、 Test Data

Type	Input		Load	Test
	V_I	t_r, t_f	C_L	
SN74HC157	V_{CC}	6ns	15pF, 50pF	t_{PHL}, t_{PLH}
SN74HCT157	3V	6ns	15pF, 50pF	t_{PHL}, t_{PLH}



5、Package Information

5.1、DIP16

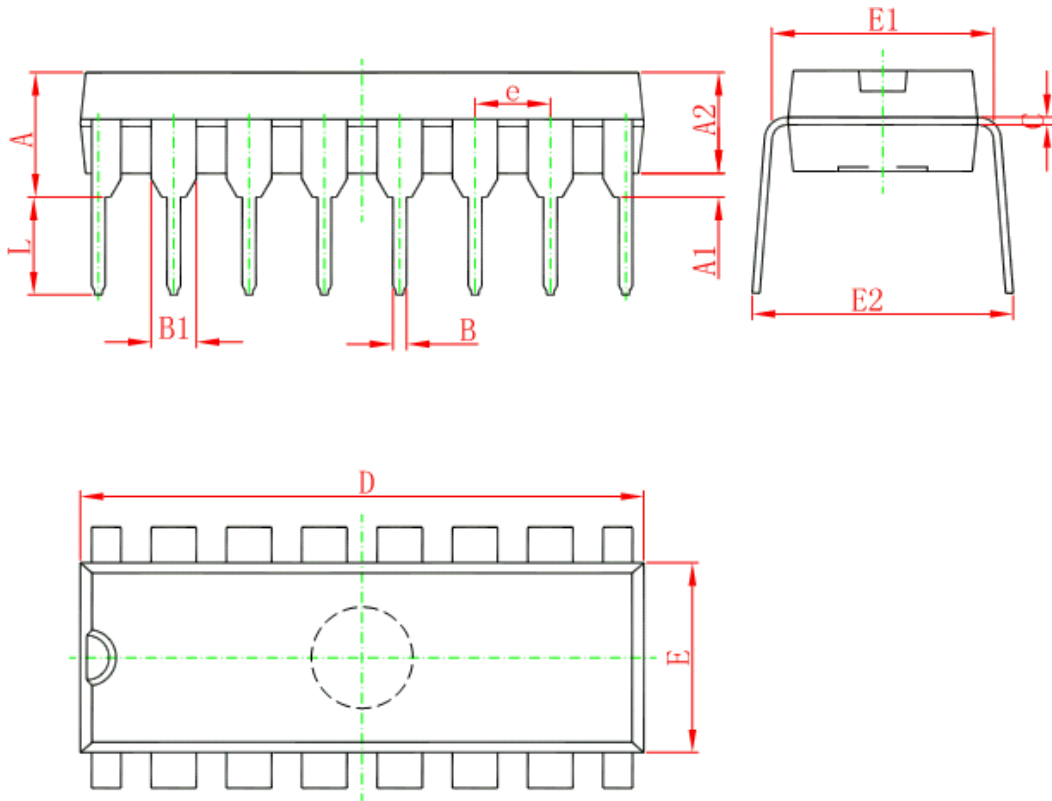

Symbol	Dimensions In Millimeters		Dimensions In Inches	
	Min	Max	Min	Max
A	3.710	4.310	0.146	0.170
A1	0.510		0.020	
A2	3.200	3.600	0.126	0.142
B	0.380	0.570	0.015	0.022
B1	1.524 (BSC)		0.060 (BSC)	
C	0.204	0.360	0.008	0.014
D	18.800	19.200	0.740	0.756
E	6.200	6.600	0.244	0.260
E1	7.320	7.920	0.288	0.312
e	2.540 (BSC)		0.100 (BSC)	
L	3.000	3.600	0.118	0.142
E2	8.400	9.000	0.331	0.354



5.2、SOP16

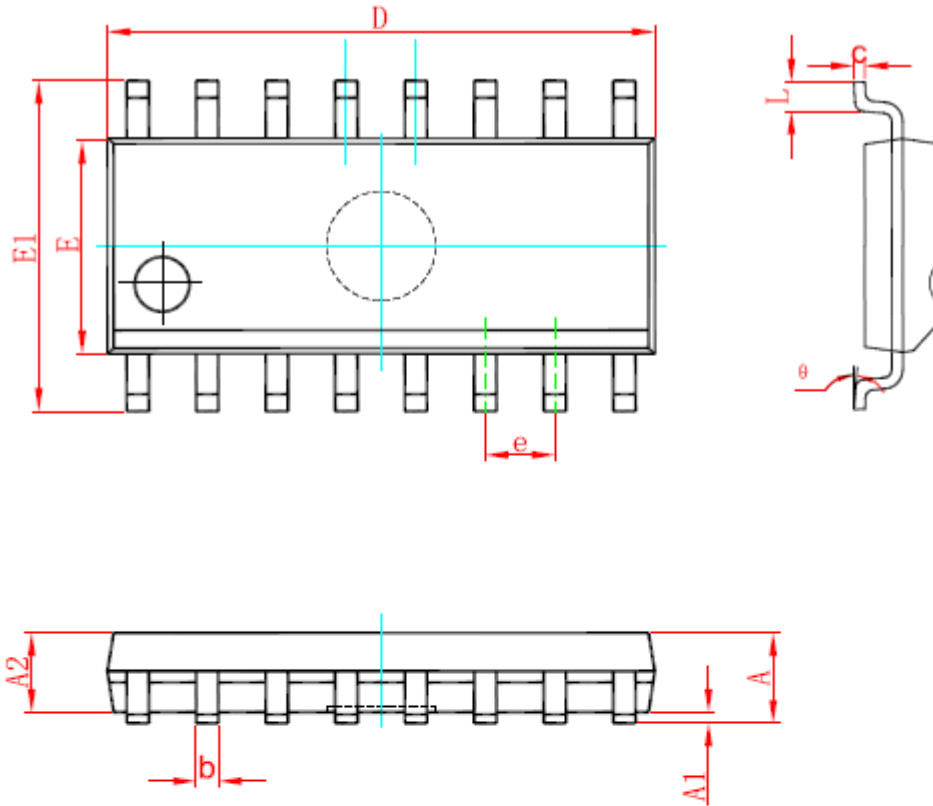

Symbol	Dimensions In Millimeters		Dimensions In Inches	
	Min	Max	Min	Max
A	1.350	1.750	0.053	0.069
A1	0.100	0.250	0.004	0.010
A2	1.350	1.550	0.053	0.061
b	0.330	0.510	0.013	0.020
c	0.170	0.250	0.007	0.010
D	9.800	10.200	0.386	0.402
E	3.800	4.000	0.150	0.157
E1	5.800	6.200	0.228	0.244
e	1.270 (BSC)		0.050 (BSC)	
L	0.400	1.270	0.016	0.050
θ	0°	8°	0°	8°



5.3、TSSOP16

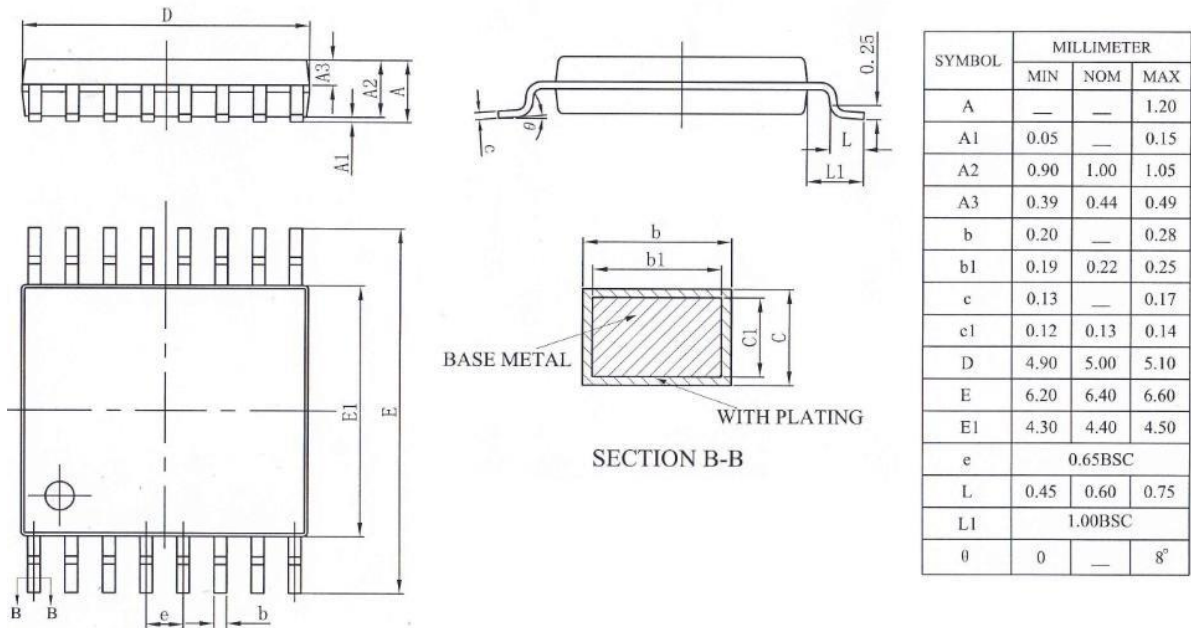



6、 Statements And Notes

6.1 、 The name and content of Hazardous substances or Elements in the product

Part name	Hazardous substances or Elements									
	Lead and lead compounds	Mercury and mercury compounds	Cadmium and cadmium compounds	Hexavalent chromium compounds	Polybrominated biphenyls	Polybrominated biphenyl ethers	Dibutyl phthalate	Butylbenzyl phthalate	Di-2-ethylhexyl phthalate	Diisobutyl phthalate
Lead frame	○	○	○	○	○	○	○	○	○	○
Plastic resin	○	○	○	○	○	○	○	○	○	○
Chip	○	○	○	○	○	○	○	○	○	○
The lead	○	○	○	○	○	○	○	○	○	○
Plastic sheet installed	○	○	○	○	○	○	○	○	○	○
explanation	○: Indicates that the content of hazardous substances or elements in the detection limit of the following the SJ/T11363-2006 standard. ×: Indicates that the content of hazardous substances or elements exceeding the SJ/T11363-2006 Standard limit requirements.									

6.2 、 Notion

Recommended carefully reading this information before the use of this product;

The information in this document are subject to change without notice;

This information is using to the reference only, the company is not responsible for any loss;

The company is not responsible for the any infringement of the third party patents or other rights of the responsibility.

X-ON Electronics

Largest Supplier of Electrical and Electronic Components

Click to view similar products for [Encoders, Decoders, Multiplexers & Demultiplexers](#) *category:*

Click to view products by [lingxingic](#) *manufacturer:*

Other Similar products are found below :

[MC74HC163ADTG](#) [74HC253N](#) [NLV74VHC1G01DFT1G](#) [NLVHCT4851ADTR2G](#) [NLV14028BDR2G](#) [COMX-CAR-210](#) [SN74LS148N](#)
[PI3B3251LE](#) [PI3B3251QE](#) [NLV74HC4851AMNTWG](#) [MC74LVX257DG](#) [M74HCT4851ADWR2G](#) [NL7SZ19DBVT1G](#) [PI5C3253LEX](#)
[MC74HC251ADTG](#) [MC74ACT138NG](#) [NB3L8533DTR2G](#) [NLV74AC157DR2G](#) [74HC138DT](#) [74HC153DT](#) [74HC238DT](#) [74HC151DT](#)
[ADS131M02IRUKR](#) [CBMG709ATS16](#) [74HC238N](#) [HT74HC154ARWZ](#) [RS2G139XS16-G](#) [74HCT251D](#) [74HC138T](#) [U74HC138G-S16-R](#)
[AIP74HCT138SA.TB](#) [XD74C922](#) [RS1G157XC6](#) [74HC151M/TR](#) [AiP74HC237TA16.TB](#) [AIP74HC138TA16.TB](#) [74HC138DRG](#)
[AiP74LVC138TA16.TB](#) [CD4511BDRG](#) [AiP74LVC157TA16.TB](#) [SN74HC42N\(LX\)](#) [SN74LS157N\(LX\)](#) [SN74LS42N](#) [TC4053BFT\(EL,N\)](#)
[74VHC4052AFT\(BE\)](#) [TC74VHC138FK\(EL,K\)](#) [TC74HC151AF\(EL,F\)](#) [SN74HC145DR\(LX\)](#) [SN74HC139DR\(LX\)](#) [CD4028BM\(LX\)](#)