



SN74HC166/HCT166 (LX) 8-bit parallel-in/serial out shift register

Product Specification

Specification Revision History:

Version	Date	Description
2023-10-A0	2023-10	New
2023-11-A1	2023-11	Parameter modification
2024-04-A2	2024-04	Modify the content



Contents

1、 General Description.....	1
2、 Block Diagram And Pin Description	2
2.1、 Block Diagram	2
2.2、 Pin Configurations.....	2
2.3、 Pin Description.....	3
2.4、 Function Table.....	3
3、 Electrical Parameter	4
3.1、 Absolute Maximum Ratings.....	4
3.2、 Recommended Operating Conditions.....	4
3.3、 Electrical Characteristics	5
3.3.1、 DC Characteristics 1	5
3.3.2、 DC Characteristics 2.....	6
3.3.3、 AC Characteristics 1	7
3.3.4、 AC Characteristics 2.....	9
4、 Testing Circuit	10
4.1、 AC Testing Circuit	10
4.2、 Test Data	11
4.3、 AC Testing Waveforms.....	11
4.4、 Measurement Points	12
5、 Package Information	13
5.1、 DIP16	13
5.2、 SOP16.....	14
5.3、 TSSOP16.....	15
6、 Statements And Notes	16



1、General Description

The SN74HC/HCT166 is an 8-bit serial or parallel-in/serial-out shift register.

Features:

- Supply voltage range:
SN74HC166: 2~6V
SN74HCT166: 4.5~5.5V
- Input levels:
SN74HC166: CMOS level
SN74HCT166: TTL level
- Temperature range: -40°C to +125°C
- Packaging information: DIP16/SOP16/TSSOP16

Ordering Information:

Tube packing specifications:

Part number	Packaging form	Marking code	Tube quantity	Boxed tube quantity	Boxed quantity	Notes
SN74HC166N(LX)	DIP16	SN74HC166N	25 PCS/tube	40 tube/box	1000 PCS/box	Dimensions of plastic enclosure: 19.0mm×6.4mm Pin spacing: 2.54mm
SN74HCT166N(LX)	DIP16	SN74HCT166N	25 PCS/tube	40 tube/box	1000 PCS/box	Dimensions of plastic enclosure: 19.0mm×6.4mm Pin spacing: 2.54mm

Reel packing specifications:

Part number	Packaging form	Markingcode	Reel quantity	Boxed reel quantity	Notes
SN74HC166DR(LX)	SOP16	HC166	2500 PCS/reel	5000 PCS/box	Dimensions of plastic enclosure: 8.7mm×3.9mm Pin spacing: 1.27mm
SN74HCT166DR(LX)	SOP16	HCT166	2500 PCS/reel	5000 PCS/box	Dimensions of plastic enclosure: 8.7mm×3.9mm Pin spacing: 1.27mm
SN74HC166PW(LX)	TSSOP16	HC166	5000 PCS/reel	10000 PCS/box	Dimensions of plastic enclosure: 5.0mm×4.4mm Pin spacing: 0.65mm
SN74HCT166PW(LX)	TSSOP16	HCT166	5000 PCS/reel	10000 PCS/box	Dimensions of plastic enclosure: 5.0mm×4.4mm Pin spacing: 0.65mm

Note: If the physical information is inconsistent with the ordering information, please refer to the actual product.



2、Block Diagram And Pin Description

2.1、Block Diagram

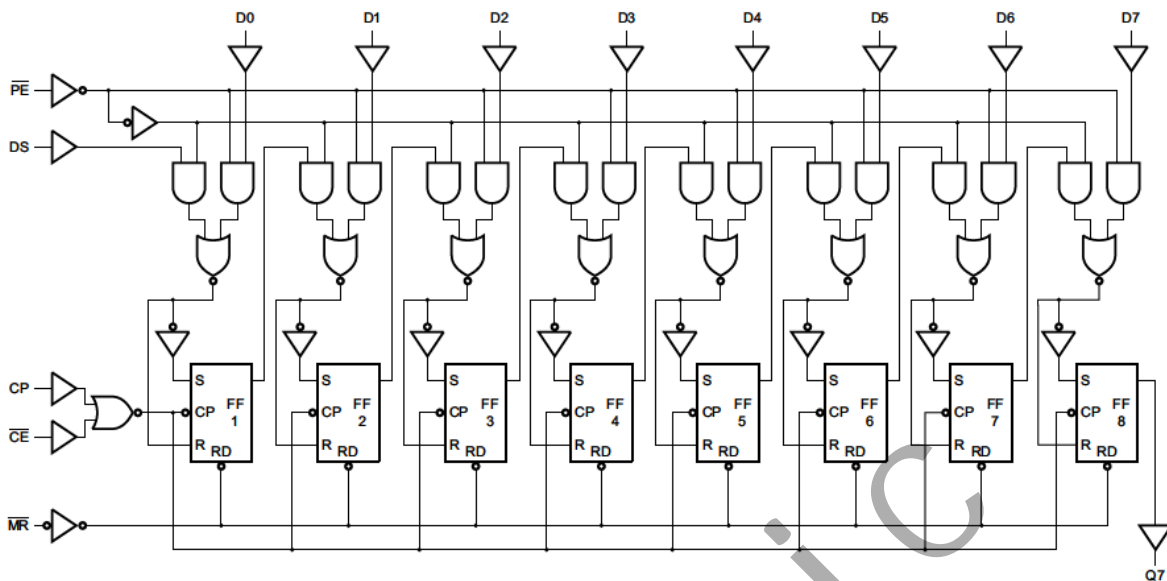
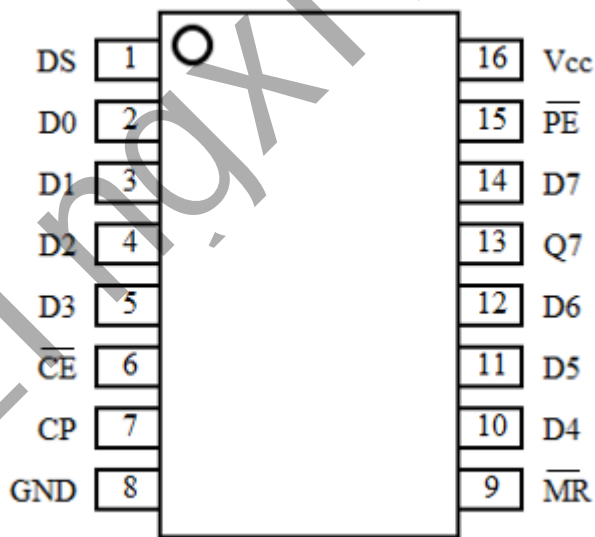

Figure 1. Logic symbol

2.2、Pin Configurations





2.3、Pin Description

Pin No.	Pin Name	Description
1	DS	serial data input
2	D0	parallel data input
3	D1	parallel data input
4	D2	parallel data input
5	D3	parallel data input
6	\overline{CE}	clock enable input (active LOW)
7	CP	clock input (LOW-to-HIGH edge-triggered)
8	GND	ground (0V)
9	\overline{MR}	asynchronous master reset (active LOW)
10	D4	parallel data input
11	D5	parallel data input
12	D6	parallel data input
13	Q7	serial output from the last stage
14	D7	parallel data input
15	\overline{PE}	parallel enable input (active LOW)
16	V _{CC}	supply voltage

2.4、Function Table

Operating modes	Inputs					Qn registers		Output
	\overline{PE}	\overline{CE}	CP	DS	D0 to D7	Q0	Q1 to Q6	Q7
parallel load	l	l	↑	X	l	L	L to L	L
	l	l	↑	X	h	H	H to H	H
serial shift	h	l	↑	l	X	L	q0 to q5	q6
	h	l	↑	h	X	H	q0 to q5	q6
hold "do nothing"	X	H	X	X	X	q0	q1 to q6	q7

Note:

H = HIGH voltage level;

h = HIGH voltage level one set-up time prior to the LOW-to-HIGH clock transition;

L = LOW voltage level;

l = LOW voltage level one set-up time prior to the LOW-to-HIGH clock transition;

q = state of the referenced output one set-up time prior to the LOW-to-HIGH clock transition;

X = don't care;

↑ = LOW-to-HIGH clock transition.



3、Electrical Parameter

3.1、Absolute Maximum Ratings

(Voltages are referenced to GND (ground=0V), unless otherwise specified.)

Parameter	Symbol	Conditions	Min.	Max.	Unit
supply voltage	V_{CC}	-	-0.5	+7	V
supply current	I_{CC}	-	-	50	mA
ground current	I_{GND}	-	-50	-	mA
input clamping current	I_{IK}	$V_I < -0.5V$ or $V_I > V_{CC}+0.5V$	-	± 20	mA
output clamping current	I_{OK}	$V_O < -0.5V$ or $V_O > V_{CC}+0.5V$	-	± 20	mA
output current	I_O	$-0.5V < V_O < V_{CC}+0.5V$	-	± 25	mA
storage temperature	T_{stg}	-	-65	+150	$^{\circ}C$
soldering temperature	T_L	10s	DIP		$^{\circ}C$
			SOP/TSSOP		

3.2、Recommended Operating Conditions

Parameter	Symbol	Conditions	Min.	Typ.	Max.	Unit
SN74HC166						
supply voltage	V_{CC}	-	2.0	5.0	6.0	V
input voltage	V_I	-	0	-	V_{CC}	V
output voltage	V_O	-	0	-	V_{CC}	V
ambient temperature	T_{amb}	-	-40	-	+125	$^{\circ}C$
SN74HCT166						
supply voltage	V_{CC}	-	4.5	5.0	5.5	V
input voltage	V_I	-	0	-	V_{CC}	V
output voltage	V_O	-	0	-	V_{CC}	V
ambient temperature	T_{amb}	-	-40	-	+125	$^{\circ}C$



3.3、Electrical Characteristics

3.3.1、DC Characteristics 1

($T_{amb} = -40^{\circ}\text{C}$ to $+85^{\circ}\text{C}$, voltages are referenced to GND (ground=0V), unless otherwise specified.)

Parameter	Symbol	V _{CC}	Conditions	Min.	Typ.	Max.	Unit
SN74HC166							
HIGH-level input voltage	V _{IH}	2.0V	-	1.5	1.2	-	V
		4.5V	-	3.15	2.4	-	V
		6.0V	-	4.2	3.2	-	V
LOW-level input voltage	V _{IL}	2.0V	-	-	0.8	0.5	V
		4.5V	-	-	2.1	1.35	V
		6.0V	-	-	2.8	1.8	V
HIGH-level output voltage	V _{OH}	2.0V	I _O = -20uA	1.9	2.0	-	V
		4.5V	I _O = -20uA	4.4	4.5	-	V
		6.0V	I _O = -20uA	5.9	6.0	-	V
		4.5V	I _O = -4.0mA	3.84	4.32	-	V
		6.0V	I _O = -5.2mA	5.34	5.81	-	V
LOW-level output voltage	V _{OL}	2.0V	I _O = 20uA	-	0	0.1	V
		4.5V	I _O = 20uA	-	0	0.1	V
		6.0V	I _O = 20uA	-	0	0.1	V
		4.5V	I _O = 4.0mA	-	0.15	0.33	V
		6.0V	I _O = 5.2mA	-	0.16	0.33	V
input leakage current	I _I	6.0V	V _I = V _{CC} or GND	-	-	±1	uA
supply current	I _{CC}	6.0V	V _I = V _{CC} or GND; I _O = 0A	-	-	80	uA
SN74HCT166							
HIGH-level input voltage	V _{IH}	4.5~5.5V	-	2.0	1.6	-	V
LOW-level input voltage	V _{IL}	4.5~5.5V	-	-	1.2	0.8	V
HIGH-level output voltage	V _{OH}	4.5V	I _O = -20uA	4.4	4.5	-	V
			I _O = -4.0mA	3.84	4.32	-	V
LOW-level output voltage	V _{OL}	4.5V	I _O = 20uA	-	0	0.1	V
			I _O = 5.2mA	-	0.16	0.33	V
input leakage current	I _I	5.5V	V _I = V _{CC} or GND	-	-	±1	uA
supply current	I _{CC}	4.5V	V _I = V _{CC} or GND; I _O = 0A	-	-	80	uA
additional supply current	ΔI _{CC}	4.5~5.5V	One input at V _I = V _{CC} - 2.1V; Other inputs at V _{CC} or GND; I _O = 0A	-	-	135	uA



3.3.2、DC Characteristics 2

($T_{amb} = -40^{\circ}\text{C}$ to $+125^{\circ}\text{C}$, voltages are referenced to GND (ground=0V), unless otherwise specified.)

Parameter	Symbol	V _{CC}	Conditions	Min.	Typ.	Max.	Unit
SN74HC166							
HIGH-level input voltage	V _{IH}	2.0V	-	1.5	-	-	V
		4.5V	-	3.15	-	-	V
		6.0V	-	4.2	-	-	V
LOW-level input voltage	V _{IL}	2.0V	-	-	-	0.5	V
		4.5V	-	-	-	1.35	V
		6.0V	-	-	-	1.8	V
HIGH-level output voltage	V _{OH}	2.0V	I _O = -20uA	1.9	-	-	V
		4.5V	I _O = -20uA	4.4	-	-	V
		6.0V	I _O = -20uA	5.9	-	-	V
		4.5V	I _O = -4.0mA	3.7	-	-	V
		6.0V	I _O = -5.2mA	5.2	-	-	V
LOW-level output voltage	V _{OL}	2.0V	I _O = 20uA	-	-	0.1	V
		4.5V	I _O = 20uA	-	-	0.1	V
		6.0V	I _O = 20uA	-	-	0.1	V
		4.5V	I _O = 4.0mA	-	-	0.4	V
		6.0V	I _O = 5.2mA	-	-	0.4	V
input leakage current	I _I	6.0V	V _I = V _{CC} or GND	-	-	±1	uA
supply current	I _{CC}	6.0V	V _I = V _{CC} or GND; I _O = 0A	-	-	160	uA
SN74HCT166							
HIGH-level input voltage	V _{IH}	4.5~5.5V	-	2.0	-	-	V
LOW-level input voltage	V _{IL}	4.5~5.5V	-	-	-	0.8	V
HIGH-level output voltage	V _{OH}	4.5V	I _O = -20uA	4.4	-	-	V
			I _O = -4.0mA	3.7	-	-	V
LOW-level output voltage	V _{OL}	4.5V	I _O = 20uA	-	-	0.1	V
			I _O = 5.2mA	-	-	0.4	V
input leakage current	I _I	5.5V	V _I = V _{CC} or GND	-	-	±1	uA
supply current	I _{CC}	4.5V	V _I = V _{CC} or GND; I _O = 0A	-	-	160	uA
additional supply current	ΔI _{CC}	4.5~5.5V	One input at V _I = V _{CC} - 2.1V; Other inputs at V _{CC} or GND; I _O = 0A	-	-	147	uA



3.3.3、AC Characteristics 1

($T_{amb} = -40^{\circ}\text{C}$ to $+85^{\circ}\text{C}$, voltages are referenced to GND (ground=0V), unless otherwise specified.)

Parameter	Symbol	V _{CC}	Conditions	Min.	Typ.	Max.	Unit	
SN74HC166								
CP to Q7 propagation delay	t_{PLH}, t_{PHL}	2.0V	$C_L=50\text{pF}$	see Figure 4	-	50	190	ns
		4.5V	$C_L=50\text{pF}$		-	18	38	ns
		5.0V	$C_L=15\text{pF}$		-	15	-	ns
		6.0V	$C_L=50\text{pF}$		-	14	33	ns
$\overline{\text{MR}}$ to Q7 propagation delay	t_{PLH}, t_{PHL}	2.0V	$C_L=50\text{pF}$	see Figure 5	-	47	200	ns
		4.5V	$C_L=50\text{pF}$		-	17	40	ns
		5.0V	$C_L=15\text{pF}$		-	14	-	ns
		6.0V	$C_L=50\text{pF}$		-	14	34	ns
transition time	t_{THL}, t_{TLH}	2.0V	$C_L=50\text{pF}$	see Figure 4	-	19	95	ns
		4.5V	$C_L=50\text{pF}$		-	7	19	ns
		6.0V	$C_L=50\text{pF}$		-	6	16	ns
CP input HIGH or LOW pulse width	t_w	2.0V	$C_L=50\text{pF}$	see Figure 4	100	17	-	ns
		4.5V	$C_L=50\text{pF}$		20	6	-	ns
		6.0V	$C_L=50\text{pF}$		17	5	-	ns
$\overline{\text{MR}}$ input LOW pulse width	t_w	2.0V	$C_L=50\text{pF}$	see Figure 5	125	25	-	ns
		4.5V	$C_L=50\text{pF}$		25	9	-	ns
		6.0V	$C_L=50\text{pF}$		21	7	-	ns
$\overline{\text{MR}}$ to CP recovery time	t_{rec}	2.0V	$C_L=50\text{pF}$	see Figure 5	0	-19	-	ns
		4.5V	$C_L=50\text{pF}$		0	-7	-	ns
		6.0V	$C_L=50\text{pF}$		0	-6	-	ns
Dn, $\overline{\text{CE}}$ to CP set_up time	t_{su}	2.0V	$C_L=50\text{pF}$	see Figure 6	100	14	-	ns
		4.5V	$C_L=50\text{pF}$		20	5	-	ns
		6.0V	$C_L=50\text{pF}$		17	4	-	ns
$\overline{\text{PE}}$ to CP set_up time	t_{su}	2.0V	$C_L=50\text{pF}$	see Figure 6	125	33	-	ns
		4.5V	$C_L=50\text{pF}$		25	12	-	ns
		6.0V	$C_L=50\text{pF}$		21	10	-	ns
Dn, $\overline{\text{CE}}$ to CP hold time	t_h	2.0V	$C_L=50\text{pF}$	see Figure 6	2	-8	-	ns
		4.5V	$C_L=50\text{pF}$		2	-3	-	ns
		6.0V	$C_L=50\text{pF}$		2	-2	-	ns
$\overline{\text{PE}}$ to CP hold time	t_h	2.0V	$C_L=50\text{pF}$	see Figure 6	0	-28	-	ns
		4.5V	$C_L=50\text{pF}$		0	-10	-	ns
		6.0V	$C_L=50\text{pF}$		0	-8	-	ns
maximum frequency	f_{max}	2.0V	$C_L=50\text{pF}$	see Figure 4	4.8	19	-	MHZ
		4.5V	$C_L=50\text{pF}$		24	57	-	MHZ
		5.0V	$C_L=15\text{pF}$		-	63	-	MHZ
		6.0V	$C_L=50\text{pF}$		28	68	-	MHZ



SN74HCT166								
CP to Q7 propagation delay		4.5V	$C_L=50\text{pF}$	see Figure 4	-	23	50	ns
		5.0V	$C_L=15\text{pF}$		-	20	-	ns
MR to Q7 propagation delay	t_{PLH}, t_{PHL}	4.5V	$C_L=50\text{pF}$	see Figure 5	-	22	50	ns
		5.0V	$C_L=15\text{pF}$		-	19	-	ns
transition time	t_{THL}, t_{TLH}	4.5V	$C_L=50\text{pF}$	see Figure 4	-	7	19	ns
CP input HIGH or LOW pulse width	tw	4.5V	$C_L=50\text{pF}$	see Figure 4	25	9	-	ns
MR input LOW pulse width		4.5V	$C_L=50\text{pF}$	see Figure 5	31	11	-	ns
MR to CP recovery time	trec	4.5V	$C_L=50\text{pF}$	see Figure 5	0	-7	-	ns
Dn, CE to CP set_up time	tsu	4.5V	$C_L=50\text{pF}$	see Figure 6	20	8	-	ns
PE to CP set_up time		4.5V	$C_L=50\text{pF}$		38	15	-	ns
Dn, CE to CP hold time	th	4.5V	$C_L=50\text{pF}$	see Figure 6	0	-3	-	ns
PE to CP hold time		4.5V	$C_L=50\text{pF}$		0	-13	-	ns
maximum frequency	fmax	4.5V	$C_L=50\text{pF}$	see Figure 4	20	45	-	MHZ
		5.0V	$C_L=15\text{pF}$		-	50	-	MHZ



3.3.4、AC Characteristics 2

($T_{amb} = -40^{\circ}\text{C}$ to $+125^{\circ}\text{C}$, voltages are referenced to GND (ground=0V), unless otherwise specified.)

Parameter	Symbol	V _{CC}	Conditions	Min.	Typ.	Max.	Unit	
SN74HC166								
CP to Q7 propagation delay	t_{PLH}, t_{PHL}	2.0V	$C_L=50\text{pF}$	see Figure 4	-	-	225	ns
		4.5V	$C_L=50\text{pF}$		-	-	45	ns
		6.0V	$C_L=50\text{pF}$		-	-	38	ns
MR to Q7 propagation delay	t_{PLH}, t_{PHL}	2.0V	$C_L=50\text{pF}$	see Figure 5	-	-	240	ns
		4.5V	$C_L=50\text{pF}$		-	-	48	ns
		6.0V	$C_L=50\text{pF}$		-	-	41	ns
transition time	t_{THL}, t_{TLH}	2.0V	$C_L=50\text{pF}$	see Figure 4	-	-	110	ns
		4.5V	$C_L=50\text{pF}$		-	-	22	ns
		6.0V	$C_L=50\text{pF}$		-	-	19	ns
CP input HIGH or LOW pulse width	tw	2.0V	$C_L=50\text{pF}$	see Figure 4	120	-	-	ns
		4.5V	$C_L=50\text{pF}$		24	-	-	ns
		6.0V	$C_L=50\text{pF}$		20	-	-	ns
MR input LOW pulse width	tw	2.0V	$C_L=50\text{pF}$	see Figure 5	150	-	-	ns
		4.5V	$C_L=50\text{pF}$		30	-	-	ns
		6.0V	$C_L=50\text{pF}$		26	-	-	ns
MR to CP recovery time	trec	2.0V	$C_L=50\text{pF}$	see Figure 5	0	-	-	ns
		4.5V	$C_L=50\text{pF}$		0	-	-	ns
		6.0V	$C_L=50\text{pF}$		0	-	-	ns
Dn, CE to CP set_up time	tsu	2.0V	$C_L=50\text{pF}$	see Figure 6	120	-	-	ns
		4.5V	$C_L=50\text{pF}$		24	-	-	ns
		6.0V	$C_L=50\text{pF}$		20	-	-	ns
PE to CP set_up time	tsu	2.0V	$C_L=50\text{pF}$	see Figure 6	150	-	-	ns
		4.5V	$C_L=50\text{pF}$		30	-	-	ns
		6.0V	$C_L=50\text{pF}$		26	-	-	ns
Dn, CE to CP hold time	th	2.0V	$C_L=50\text{pF}$	see Figure 6	2	-	-	ns
		4.5V	$C_L=50\text{pF}$		2	-	-	ns
		6.0V	$C_L=50\text{pF}$		2	-	-	ns
PE to CP hold time	th	2.0V	$C_L=50\text{pF}$	see Figure 6	0	-	-	ns
		4.5V	$C_L=50\text{pF}$		0	-	-	ns
		6.0V	$C_L=50\text{pF}$		0	-	-	ns
maximum frequency	fmax	2.0V	$C_L=50\text{pF}$	see Figure 4	4	-	-	MHZ
		4.5V	$C_L=50\text{pF}$		20	-	-	MHZ
		6.0V	$C_L=50\text{pF}$		24	-	-	MHZ



SN74HCT166								
CP to Q7 propagation delay	t_{PLH}, t_{PHL}	4.5V	$C_L=50pF$	see Figure 4	-	-	60	ns
MR to Q7 propagation delay		4.5V	$C_L=50pF$	see Figure 5	-	-	60	ns
transition time	t_{THL}, t_{TLH}	4.5V	$C_L=50pF$	see Figure 4	-	-	22	ns
CP input HIGH or LOW pulse width	tw	4.5V	$C_L=50pF$	see Figure 4	30	-	-	ns
MR input LOW pulse width		4.5V	$C_L=50pF$	see Figure 5	38	-	-	ns
MR to CP recovery time	trec	4.5V	$C_L=50pF$	see Figure 5	0	-	-	ns
Dn, CE to CP set_up time	tsu	4.5V	$C_L=50pF$	see Figure 6	24	-	-	ns
PE to CP set_up time		4.5V	$C_L=50pF$		45	-	-	ns
Dn, CE to CP hold time	th	4.5V	$C_L=50pF$	see Figure 6	0	-	-	ns
PE to CP hold time		4.5V	$C_L=50pF$		0	-	-	ns
maximum frequency	fmax	4.5V	$C_L=50pF$	see Figure 4	17	-	-	MHZ

4、Testing Circuit

4.1、AC Testing Circuit

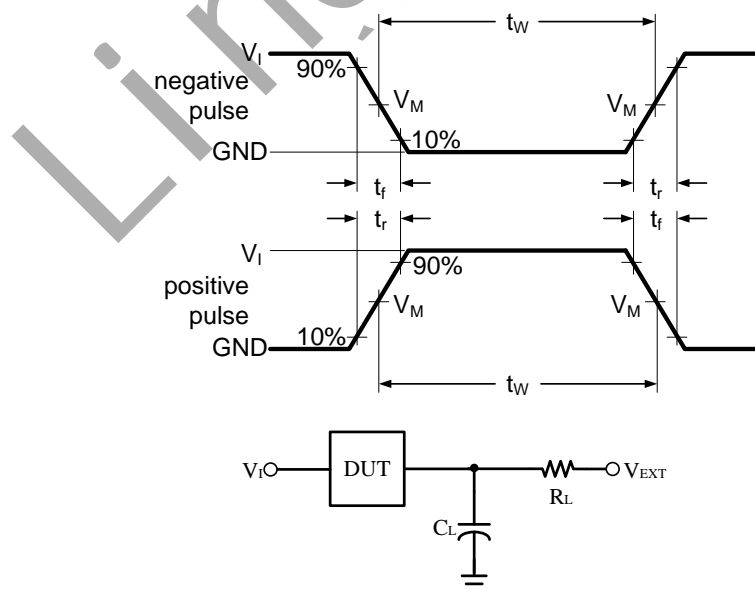

Figure 3. Test circuit for measuring switching times

C_L includes probe and jig capacitance.



4.2、Test Data

Type	Input		Load		V _{EXT}		
	V _I	t _r = t _f	C _L	R _L	t _{PLH} /t _{PHL}	t _{PLZ} /t _{PZL}	t _{PHZ} /t _{PZH}
SN74HC166	V _{CC}	3.0ns	15pF, 50pF	1KΩ	Open	V _{CC}	GND
SN74HCT166	3.0V	3.0ns	15pF, 50pF	1KΩ	Open	V _{CC}	GND

4.3、AC Testing Waveforms

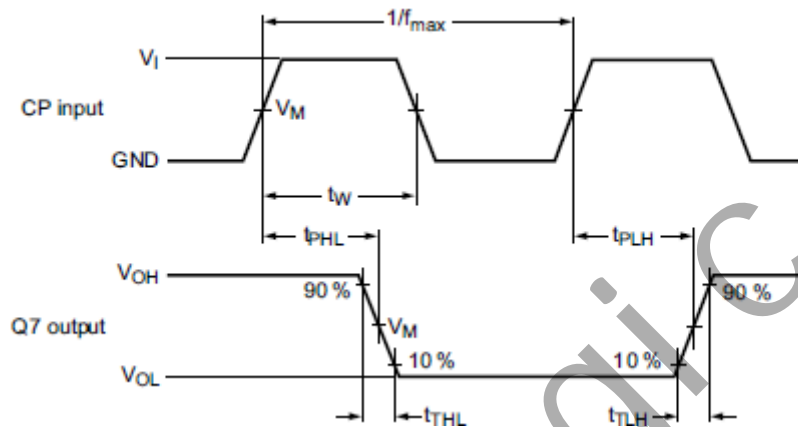

Figure 4. Clock (CP) to output (Q7) propagation delays, pulse width, output transition times and maximum Frequency

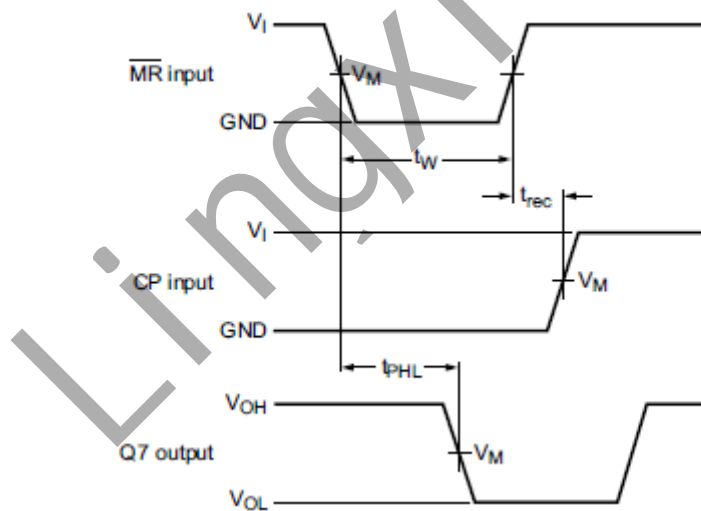

Figure 5. Master reset (\bar{MR}) pulse width, \bar{MR} to output (Q7) propagation delay and \bar{MR} to clock (CP) recovery time

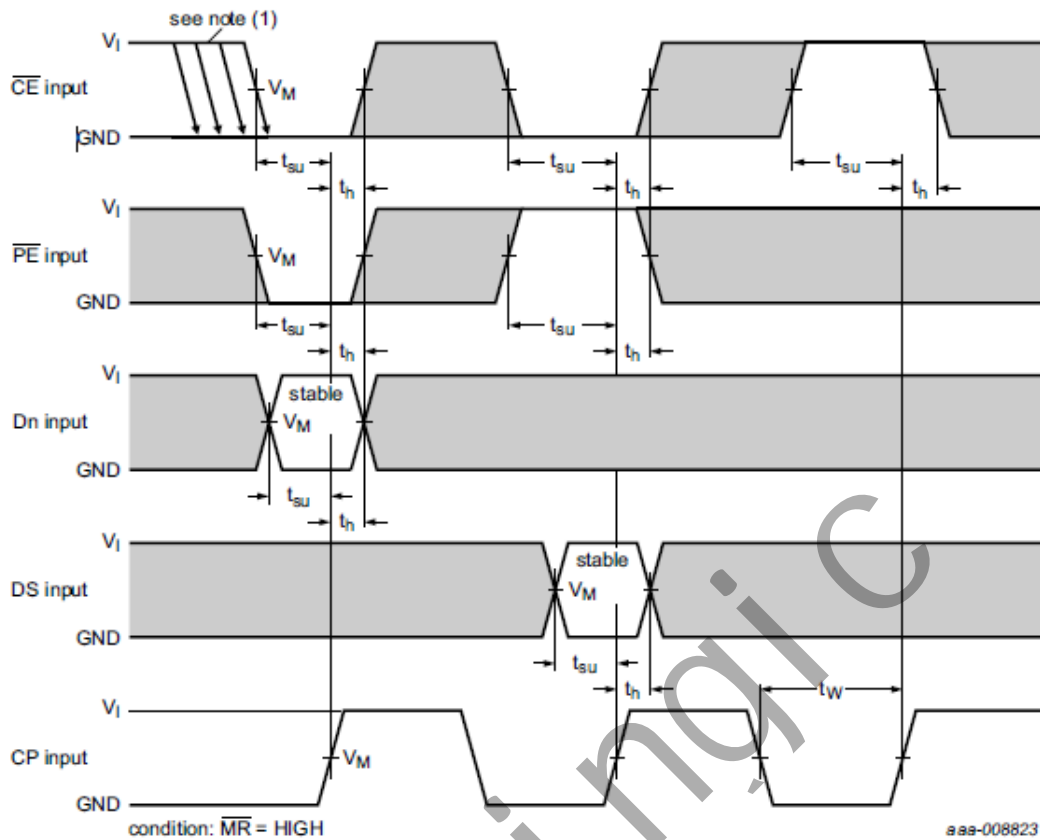

Figure 6. Set-up and hold times

4.4. Measurement Points

Type	Input	Output
	V_M	V_M
SN74HC166	$0.5 \times V_{CC}$	$0.5 \times V_{CC}$
SN74HCT166	1.3V	1.3V



5、Package Information

5.1、DIP16

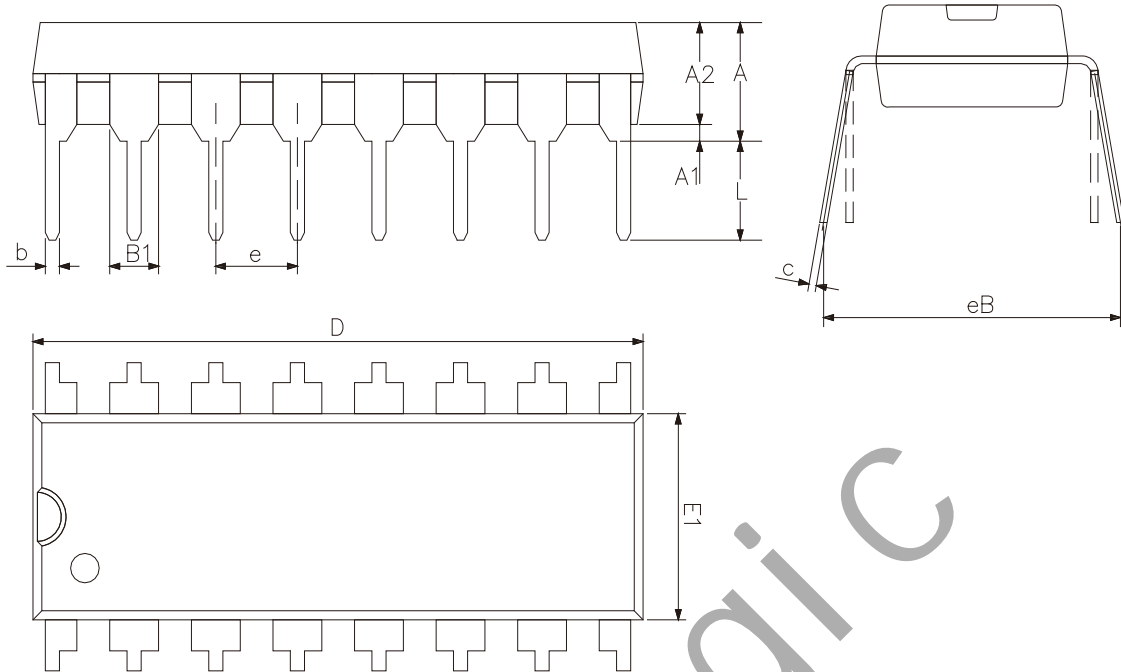

2023/12/A	Dimensions In Millimeters	
Symbol	Min	Max
A2	3.20	3.60
A1	0.51	—
A	3.60	5.33
L	3.00	—
b	0.36	0.56
B1	1.52	
D	18.80	19.94
E1	6.20	6.60
e	2.54	
c	0.20	0.36
eB	7.62	9.30



5.2、SOP16

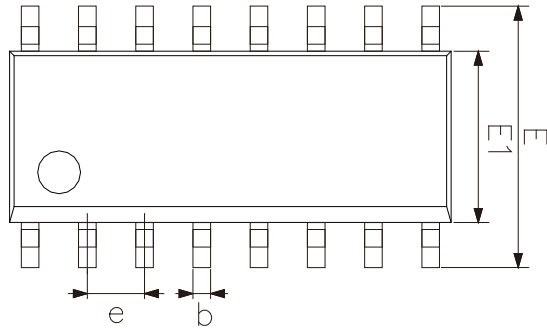
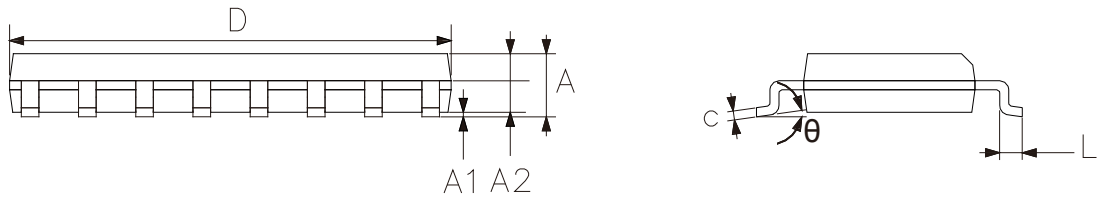

2023/12/A Symbol	Dimensions In Millimeters	
	Min.	Max.
A	1.35	1.80
A1	0.10	0.25
A2	1.25	1.55
b	0.33	0.51
c	0.19	0.25
D	9.50	10.10
E	5.80	6.30
E1	3.70	4.10
e	1.27	
L	0.35	0.89
θ	0°	8°



5.3、TSSOP16

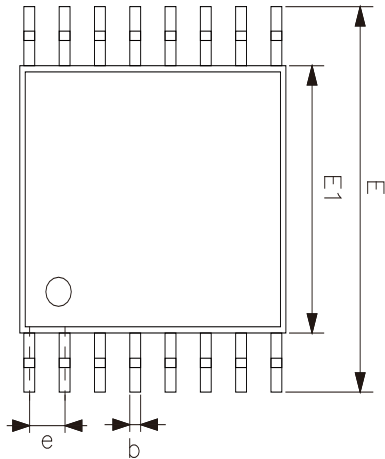
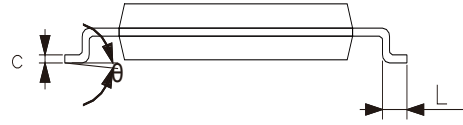
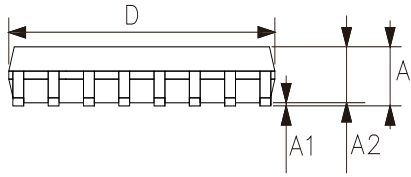

2023/12/A Symbol	Dimensions In Millimeters	
	Min	Max
A	—	1.20
A1	0.05	0.15
A2	0.80	1.05
b	0.19	0.30
c	0.09	0.20
D	4.90	5.10
E1	4.30	4.50
E	6.20	6.60
e	0.65	
L	0.45	0.75
θ	0°	8°



灵星芯微 同芯共赢

6、Statements And Notes

Recommended carefully reading this information before the use of this product;

The information in this document are subject to change without notice;

This information is using to the reference only, the company is not responsible for any loss;

The company is not responsible for the any infringement of the third party patents or other rights of the responsibility.

Lingxingic

X-ON Electronics

Largest Supplier of Electrical and Electronic Components

Click to view similar products for [Counter Shift Registers](#) category:

Click to view products by [lingxingic](#) manufacturer:

Other Similar products are found below :

[CD4031BE](#) [CD4034BE](#) [NLV74HC165ADTR2G](#) [5962-9172201M2A](#) [MC100EP142MNG](#) [MC100EP016AMNG](#) [MC74LV594ADR2G](#)
[NLV14094BDTR2G](#) [NLV74HC589ADR2G](#) [AiP74HC595TA16.TR](#) [SN74LS295BN](#) [AIP74HC164TA14.TR](#) [TM74HC164](#) [74HC164D](#)
[AiP74HC165SA16.TR](#) [74HC573D](#) [AiP74HC165TA16.TR](#) [XL74HC597-TS](#) [74HC164MT/TR](#) [XL74HC595TS](#) [74HC595DMT/TR](#)
[CD4094DMT/TR](#) [74HC595D\(MS\)](#) [CD4094DM/TR](#) [74HC164D](#) [GN165D](#) [74HC595DM/TR](#) [AIP74HC595SA.TR](#) [XL4021B](#)
[74HC164D\(MS\)](#) [74HC595MT/TR](#) [XL74HC165-TS](#) [74HC595D](#) [74HC595D](#) [74HC595D.](#) [74HCT595BQ](#) [RS595SXTSS16](#)
[Aip74HC595SA16.TR](#) [SN74LS164DR-HXY](#) [74HC164DR](#) [RS595SXS16](#) [74HC165-HXY](#) [RS164XQ](#) [GN74HC595D](#) [74HC164DRG](#)
[XD74HC165](#) [SN74LV165AQWBQBRQ1](#) [AiP74HC4094SA16.TR](#) [HX74HC595IDRG](#) [CD4094DN](#)