



SN74HC/HCT193

Presettable Synchronous 4-bit Binary up/down Counter; Asynchronous Reset

Product Specification

Specification Revision History:

Version	Date	Description
2021-12-A2	2021-12	Modify Ordering Information
2022-01-A3	2022-01	Modify ambient temperature to $-40^{\circ}\text{C}\sim+105^{\circ}\text{C}$ and add electrical characteristics of $-40^{\circ}\text{C}\sim+105^{\circ}\text{C}$



1、General Description

The SN74HC/HCT193 is a 4-bit synchronous binary up/down counter. Separate up/down clocks, CPU and CPD respectively, simplify operation. The outputs change state synchronously with the LOW-to-HIGH transition of either clock input. If the CPU clock is pulsed while CPD is held HIGH, the device will count up. If the CPD clock is pulsed while CPU is held HIGH, the device will count down.

Only one clock input can be held HIGH at any time to guarantee predictable behavior. The device can be cleared at any time by the asynchronous master reset input (MR); it may also be loaded in parallel by activating the asynchronous parallel load input (PL). The terminal count up (TCU) and terminal count

down (TCD) outputs are normally HIGH. When the circuit has reached the maximum count state of 15, the next HIGH-to-LOW transition of CPU will cause TCU to go LOW. TCU will stay LOW until CPU goes HIGH again, duplicating the count up clock. Likewise, the TCD output will go LOW when the circuit is in the zero state and the CPD goes LOW. The terminal count outputs can be used as the clock input signals to the next higher order circuit in a multistage counter, since they duplicate the clock waveforms. Multistage counters will not be fully synchronous, since there is a slight delay time difference added for each stage that is added. The counter may be preset by the asynchronous parallel load capability of the circuit. Information present on the parallel data inputs (D0 to D3) is loaded into the counter and appears on the outputs (Q0 to Q3) regardless of the conditions of the clock inputs when the parallel load (PL) input is LOW. A HIGH level on the master reset (MR) input will disable the parallel load gates, override both clock inputs and set all outputs (Q0 to Q3) LOW. If one of the clock inputs is LOW during and after a reset or load operation, the next LOW-to-HIGH transition of that clock will be interpreted as a legitimate signal and will be counted. Inputs include clamp diodes. This enables the use of current limiting resistors to interface inputs to voltages in excess of V_{CC} .

Features:

- Input levels:
 - For SN74HC193: CMOS level
 - For SN74HCT193: TTL level
- Synchronous reversible 4-bit binary counting
- Asynchronous parallel load
- Asynchronous reset
- Expandable without external logic
- Specified from -40°C to $+105^{\circ}\text{C}$
- Packaging information: DIP16/SOP16/TSSOP16



Ordering Information:

Tube packing specifications:

Part number	Packaging form	Marking code	Tube quantity	Boxed tube quantity	Boxed quantity	Notes
SN74HC193N	DIP16	SN74HC193N	25 PCS/tube	40 tube/box	1000 PCS/box	Dimensions of plastic enclosure: 19.0mm×6.4mm Pin spacing: 2.54mm
SN74HCT193N	DIP16	SN74HCT193N	25 PCS/tube	40 tube/box	1000 PCS/box	Dimensions of plastic enclosure: 19.0mm×6.4mm Pin spacing: 2.54mm

Reel packing specifications:

Part number	Packaging form	Marking code	Reel quantity	Boxed reel quantity	Notes
SN74HC193DR	SOP16	SN74HC193	2500 PCS/reel	8000 PCS/box	Dimensions of plastic enclosure: 10.0mm×3.9mm Pin spacing:1.27mm
SN74HCT193DR	SOP16	SN74HCT193	2500 PCS/reel	8000 PCS/box	Dimensions of plastic enclosure: 10.0mm×3.9mm Pin spacing:1.27mm
SN74HC193PW	TSSOP16	SN74HC193	5000 PCS/reel	10000 PCS/box	Dimensions of plastic enclosure: 5.0mm×4.4mm Pin spacing:0.65mm
SN74HCT193PW	TSSOP16	SN74HCT193	5000 PCS/reel	10000 PCS/box	Dimensions of plastic enclosure: 5.0mm×4.4mm Pin spacing:0.65mm

Note: If the physical information is inconsistent with the ordering information, please refer to the actual product.



2、Block Diagram And Pin Description

2.1、Block Diagram

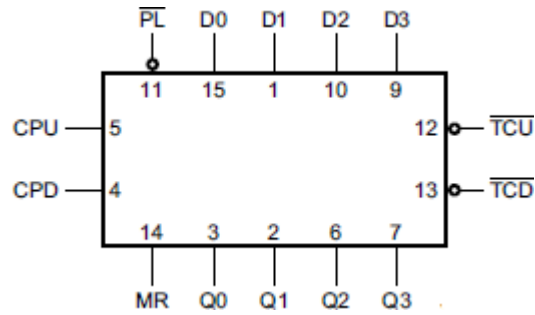

Figure 1. Logic symbol

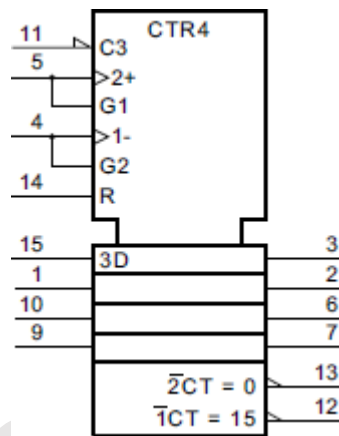

Figure 2. IEC logic symbol

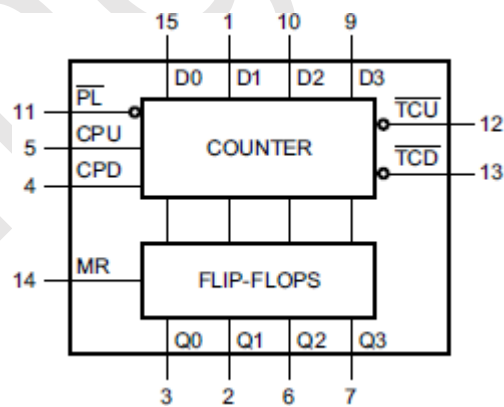

Figure 3. Functional diagram

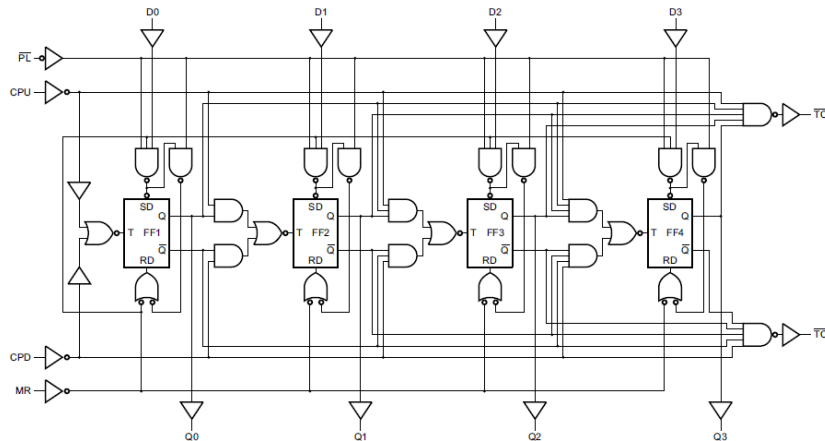
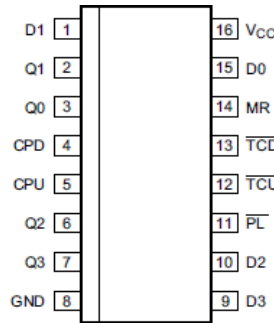

Figure 4. Logic diagram

2.2、Pin Configurations



2.3、Pin Description

Pin No.	Pin Name	Description
1	D1	data input 1
2	Q1	flip-flop output 1
3	Q0	flip-flop output 0
4	CPD	count down clock input
5	CPU	count up clock input
6	Q2	flip-flop output 2
7	Q3	flip-flop output 3
8	GND	ground (0V)
9	D3	data input 3
10	D2	data input 2
11	PL	asynchronous parallel load input (active LOW)
12	TCU	terminal count up (carry) output (active LOW)
13	TCD	terminal count down (borrow) output (active LOW)
14	MR	asynchronous master reset input (active HIGH)
15	D0	data input 0
16	VCC	supply voltage

Note: CPD, CPU is LOW-to-HIGH, edge triggered.



2.4、Function Table

Operating mode	Input								Output					
	MR	PL	CPU	CPD	D0	D1	D2	D3	Q0	Q1	Q2	Q3	TCU	TCD
Reset (clear)	H	X	X	L	X	X	X	X	L	L	L	L	H	L
	H	X	X	H	X	X	X	X	L	L	L	L	H	H
Parallel load	L	L	X	L	L	L	L	L	L	L	L	L	H	L
	L	L	X	H	L	L	L	L	L	L	L	L	H	H
	L	L	L	X	H	H	H	H	H	H	H	H	L	H
	L	L	H	X	H	H	H	H	H	H	H	H	H	H
Count up	L	H	↑	H	X	X	X	X	count up				H	H
Count down	L	H	H	↑	X	X	X	X	count down				H	H

Note:

[1] H=HIGH voltage level; L=LOW voltage level; X=don't care; ↑=LOW-to-HIGH transition.

[2] TCU=CPU at terminal count up (HHHH).

[3] TCD=CPD at terminal count down (LLLL).

3、Electrical Parameter

3.1、Absolute Maximum Ratings

(Voltages are referenced to GND(ground=0V), unless otherwise specified.)

Parameter	Symbol	Conditions	Min.	Max.	Unit	
supply voltage	V _{CC}	-	-0.5	+7.0	V	
input clamping current	I _{IK}	V _I < -0.5V or V _I > V _{CC} +0.5V	-	±20	mA	
output clamping current	I _{OK}	V _O < -0.5V or V _O > V _{CC} +0.5V	-	±20	mA	
output current	I _O	V _O = -0.5V to (V _{CC} +0.5V)	-	±25	mA	
supply current	I _{CC}	-	-	50	mA	
ground current	I _{GND}	-	-	-50	mA	
storage temperature	T _{stg}	-	-65	+150	°C	
total power dissipation	P _{tot}	-	-	500	mW	
Soldering temperature	T _L	10s	DIP		245	°C
			SOP		250	°C

Note:

[1] For DIP16 packages: above 70°C the value of P_{tot} derates linearly with 12mW/K.

[2] For SOP16 packages: above 70°C the value of P_{tot} derates linearly with 8mW/K.

[3] For (T)SSOP16 packages: above 60°C the value of P_{tot} derates linearly with 5.5mW/K.



3.2、Recommended Operating Conditions

Parameter	Symbol	Conditions	Min.	Typ.	Max.	Unit	
SN74HC193							
supply voltage	V_{CC}	-	2.0	5.0	6.0	V	
input voltage	V_I	-	0	-	V_{CC}	V	
output voltage	V_O	-	0	-	V_{CC}	V	
input transition rise and fall rate	$\Delta t/\Delta V$	-	$V_{CC}=2.0V$	-	-	625	ns/V
			$V_{CC}=4.5V$	-	1.67	139	ns/V
			$V_{CC}=6.0V$	-	-	83	ns/V
ambient temperature	T_{amb}	-	-40	-	+105	°C	
SN74HCT193							
supply voltage	V_{CC}	-	4.5	5.0	5.5	V	
input voltage	V_I	-	0	-	V_{CC}	V	
output voltage	V_O	-	0	-	V_{CC}	V	
input transition rise and fall rate	$\Delta t/\Delta V$	-	-	1.67	139	ns/V	
ambient temperature	T_{amb}	-	-40	-	+105	°C	

3.3、Electrical Characteristics

3.3.1、DC Characteristics 1

($T_{amb}=25^{\circ}C$, voltages are referenced to GND (ground=0V), unless otherwise specified.)

Parameter	Symbol	Conditions	Min.	Typ.	Max.	Unit	
SN74HC193							
HIGH-level input voltage	V_{IH}	$V_{CC}=2.0V$	1.5	1.2	-	V	
		$V_{CC}=4.5V$	3.15	2.4	-	V	
		$V_{CC}=6.0V$	4.2	3.2	-	V	
LOW-level input voltage	V_{IL}	$V_{CC}=2.0V$	-	0.8	0.5	V	
		$V_{CC}=4.5V$	-	2.1	1.35	V	
		$V_{CC}=6.0V$	-	2.8	1.8	V	
HIGH-level output voltage	V_{OH}	$V_I = V_{IH} \text{ or } V_{IL}$	$I_O=-20\mu A; V_{CC}=2.0V$	1.9	2.0	-	V
			$I_O=-20\mu A; V_{CC}=4.5V$	4.4	4.5	-	V
			$I_O=-20\mu A; V_{CC}=6.0V$	5.9	6.0	-	V
			$I_O=-4mA; V_{CC}=4.5V$	3.98	4.32	-	V
			$I_O=-5.2mA; V_{CC}=6.0V$	5.48	5.81	-	V
LOW-level output voltage	V_{OL}	$V_I = V_{IH} \text{ or } V_{IL}$	$I_O=20\mu A; V_{CC}=2.0V$	-	0	0.1	V
			$I_O=20\mu A; V_{CC}=4.5V$	-	0	0.1	V
			$I_O=20\mu A; V_{CC}=6.0V$	-	0	0.1	V
			$I_O=4mA; V_{CC}=4.5V$	-	0.15	0.26	V
			$I_O=5.2mA; V_{CC}=6.0V$	-	0.16	0.26	V
input leakage current	I_I	$V_I=V_{CC} \text{ or } GND; V_{CC}=6.0V$	-	-	± 0.1	μA	
supply current	I_{CC}	$V_I=V_{CC} \text{ or } GND; I_O=0A; V_{CC}=6.0V$	-	-	8.0	μA	
input capacitance	C_I	-	-	3.5	-	pF	



SN74HCT193							
HIGH-level input voltage	V_{IH}	$V_{CC}=4.5V$ to $5.5V$		2.0	1.6	-	V
LOW-level input voltage	V_{IL}	$V_{CC}=4.5V$ to $5.5V$		-	1.2	0.8	V
HIGH-level output voltage	V_{OH}	$V_I = V_{IH}$ or V_{IL} ; $V_{CC}=4.5V$	$I_O=-20\mu A$	4.4	4.5	-	V
			$I_O=-4mA$	3.98	4.32	-	V
LOW-level output voltage	V_{OL}	$V_I = V_{IH}$ or V_{IL} ; $V_{CC}=4.5V$	$I_O=20\mu A$	-	0	0.1	V
			$I_O=4mA$	-	0.15	0.26	V
input leakage current	I_I	$V_I=V_{CC}$ or GND; $V_{CC}=5.5V$		-	-	± 0.1	μA
supply current	I_{CC}	$V_I=V_{CC}$ or GND; $I_O=0A$; $V_{CC}=5.5V$		-	-	8.0	μA
additional supply current	ΔI_{CC}	per input pin; $V_I=V_{CC}-2.1V$; other inputs at V_{CC} or GND; $I_O=0A$; $V_{CC}=4.5V$ to $5.5V$;	pin Dn	-	35	126	μA
			pins CPU, CPD	-	140	504	μA
			pin PL	-	65	234	μA
			pin MR	-	105	378	μA
input capacitance	C_I	-		-	3.5	-	pF

3.3.2 、 DC Characteristics 2

($T_{amb}=-40^{\circ}C$ to $+85^{\circ}C$, voltages are referenced to GND (ground=0V), unless otherwise specified.)

Parameter	Symbol	Conditions	Min.	Typ.	Max.	Unit	
SN74HC193							
HIGH-level input voltage	V_{IH}	$V_{CC}=2.0V$	1.5	-	-	V	
		$V_{CC}=4.5V$	3.15	-	-	V	
		$V_{CC}=6.0V$	4.2	-	-	V	
LOW-level input voltage	V_{IL}	$V_{CC}=2.0V$	-	-	0.5	V	
		$V_{CC}=4.5V$	-	-	1.35	V	
		$V_{CC}=6.0V$	-	-	1.8	V	
HIGH-level output voltage	V_{OH}	$V_I = V_{IH}$ or V_{IL}	$I_O=-20\mu A$; $V_{CC}=2.0V$	1.9	-	-	V
			$I_O=-20\mu A$; $V_{CC}=4.5V$	4.4	-	-	V
			$I_O=-20\mu A$; $V_{CC}=6.0V$	5.9	-	-	V
			$I_O=-4mA$; $V_{CC}=4.5V$	3.84	-	-	V
			$I_O=-5.2mA$; $V_{CC}=6.0V$	5.34	-	-	V
LOW-level output voltage	V_{OL}	$V_I = V_{IH}$ or V_{IL}	$I_O=20\mu A$; $V_{CC}=2.0V$	-	-	0.1	V
			$I_O=20\mu A$; $V_{CC}=4.5V$	-	-	0.1	V
			$I_O=20\mu A$; $V_{CC}=6.0V$	-	-	0.1	V
			$I_O=4mA$; $V_{CC}=4.5V$	-	-	0.33	V
			$I_O=5.2mA$; $V_{CC}=6.0V$	-	-	0.33	V
input leakage current	I_I	$V_I=V_{CC}$ or GND; $V_{CC}=6.0V$	-	-	± 1.0	μA	
supply current	I_{CC}	$V_I=V_{CC}$ or GND; $I_O=0A$; $V_{CC}=6.0V$	-	-	80	μA	
SN74HCT193							
HIGH-level input voltage	V_{IH}	$V_{CC}=4.5V$ to $5.5V$		2.0	-	-	V



深圳市灵星芯微电子科技有限公司

Shenzhen Lingxing Microelectronics Technology Co., Ltd.

版次: B1

编号: SN74HC/HCT193-LX-A193

LOW-level input voltage	V_{IL}	$V_{CC}=4.5V$ to $5.5V$	-	-	0.8	V	
HIGH-level output voltage	V_{OH}	$V_I = V_{IH}$ or V_{IL} ; $V_{CC}=4.5V$	$I_O=-20\mu A$	4.4	-	-	V
			$I_O=-4mA$	3.84	-	-	V
LOW-level output voltage	V_{OL}	$V_I = V_{IH}$ or V_{IL} ; $V_{CC}=4.5V$	$I_O=20\mu A$	-	-	0.1	V
			$I_O=4mA$	-	-	0.33	V
input leakage current	I_I	$V_I=V_{CC}$ or GND; $V_{CC}=5.5V$	-	-	± 1.0	μA	
supply current	I_{CC}	$V_I=V_{CC}$ or GND; $I_O=0A$; $V_{CC}=5.5V$	-	-	80	μA	
additional supply current	ΔI_{CC}	per input pin; $V_I=V_{CC}-2.1V$; other inputs at V_{CC} or GND; $I_O=0A$; $V_{CC}=4.5V$ to $5.5V$;	pin Dn	-	-	157.5	μA
			pins CPU, CPD	-	-	630	μA
			pin PL	-	-	292.5	μA
			pin MR	-	-	472.5	μA

3.3.3 、DC Characteristics 3

($T_{amb}=-40^{\circ}C$ to $+105^{\circ}C$, voltages are referenced to GND (ground=0V), unless otherwise specified.)

Parameter	Symbol	Conditions	Min.	Typ.	Max.	Unit	
SN74HC193							
HIGH-level input voltage	V_{IH}	$V_{CC}=2.0V$	1.5	-	-	V	
		$V_{CC}=4.5V$	3.15	-	-	V	
		$V_{CC}=6.0V$	4.2	-	-	V	
LOW-level input voltage	V_{IL}	$V_{CC}=2.0V$	-	-	0.5	V	
		$V_{CC}=4.5V$	-	-	1.35	V	
		$V_{CC}=6.0V$	-	-	1.8	V	
HIGH-level output voltage	V_{OH}	$V_I = V_{IH}$ or V_{IL}	$I_O=-20\mu A$; $V_{CC}=2.0V$	1.9	-	-	V
			$I_O=-20\mu A$; $V_{CC}=4.5V$	4.4	-	-	V
			$I_O=-20\mu A$; $V_{CC}=6.0V$	5.9	-	-	V
			$I_O=-4mA$; $V_{CC}=4.5V$	3.7	-	-	V
			$I_O=-5.2mA$; $V_{CC}=6.0V$	5.2	-	-	V
LOW-level output voltage	V_{OL}	$V_I = V_{IH}$ or V_{IL}	$I_O=20\mu A$; $V_{CC}=2.0V$	-	-	0.1	V
			$I_O=20\mu A$; $V_{CC}=4.5V$	-	-	0.1	V
			$I_O=20\mu A$; $V_{CC}=6.0V$	-	-	0.1	V
			$I_O=4mA$; $V_{CC}=4.5V$	-	-	0.4	V
			$I_O=5.2mA$; $V_{CC}=6.0V$	-	-	0.4	V
input leakage current	I_I	$V_I=V_{CC}$ or GND; $V_{CC}=6.0V$	-	-	± 1.0	μA	
supply current	I_{CC}	$V_I=V_{CC}$ or GND; $I_O=0A$; $V_{CC}=6.0V$	-	-	160	μA	
SN74HCT193							
HIGH-level input voltage	V_{IH}	$V_{CC}=4.5V$ to $5.5V$	2.0	-	-	V	
LOW-level input voltage	V_{IL}	$V_{CC}=4.5V$ to $5.5V$	-	-	0.8	V	
HIGH-level output voltage	V_{OH}	$V_I = V_{IH}$ or V_{IL} ; $V_{CC}=4.5V$	$I_O=-20\mu A$	4.4	-	-	V
			$I_O=-4mA$	3.7	-	-	V
LOW-level output voltage	V_{OL}	$V_I = V_{IH}$ or V_{IL} ; $V_{CC}=4.5V$	$I_O=20\mu A$	-	-	0.1	V
			$I_O=4mA$	-	-	0.4	V



深圳市灵星芯微电子科技有限公司

Shenzhen Lingxing Microelectronics Technology Co., Ltd.

版次: B1

编号: SN74HC/HCT193-LX-A193

input leakage current	I_I	$V_I=V_{CC}$ or GND; $V_{CC}=5.5V$	-	-	± 1.0	μA	
supply current	I_{CC}	$V_I=V_{CC}$ or GND; $I_O=0A$; $V_{CC}=5.5V$	-	-	160	μA	
additional supply current	ΔI_{CC}	per input pin; $V_I=V_{CC}-2.1V$; other inputs at V_{CC} or GND; $I_O=0A$; $V_{CC}=4.5V$ to $5.5V$;	pin Dn	-	-	171.5	μA
			pins CPU, CPD	-	-	686	μA
			pin PL	-	-	318.5	μA
			pin MR	-	-	514.5	μA

3.3.4 、 AC Characteristics 1

($T_{amb}=25^{\circ}C$, voltages are referenced to GND (ground=0V), unless otherwise specified.)

Parameter	Symbol	Conditions	Min.	Typ.	Max.	Unit			
SN74HC193									
propagation delay	t_{pd}	CPU, CPD to Qn; see Figure 6	$V_{CC}=2.0V$	-	63	215	ns		
			$V_{CC}=4.5V$	-	23	43	ns		
			$V_{CC}=6.0V$	-	18	37	ns		
		CPU to TCU; see Figure 7	$V_{CC}=2.0V$	-	39	125	ns		
			$V_{CC}=4.5V$	-	14	25	ns		
			$V_{CC}=6.0V$	-	11	21	ns		
		CPD to TCD; see Figure 7	$V_{CC}=2.0V$	-	39	125	ns		
			$V_{CC}=4.5V$	-	14	25	ns		
			$V_{CC}=6.0V$	-	11	21	ns		
		PL to Qn; see Figure 8	$V_{CC}=2.0V$	-	69	220	ns		
			$V_{CC}=4.5V$	-	25	44	ns		
			$V_{CC}=6.0V$	-	20	37	ns		
		MR to Qn; see Figure 9	$V_{CC}=2.0V$	-	58	200	ns		
			$V_{CC}=4.5V$	-	21	40	ns		
			$V_{CC}=6.0V$	-	17	34	ns		
		Dn to Qn; see Figure 8	$V_{CC}=2.0V$	-	69	210	ns		
			$V_{CC}=4.5V$	-	25	42	ns		
			$V_{CC}=6.0V$	-	20	36	ns		
		PL to TCU, PL to TCD; see Figure 11	$V_{CC}=2.0V$	-	80	290	ns		
			$V_{CC}=4.5V$	-	29	58	ns		
			$V_{CC}=6.0V$	-	23	49	ns		
		MR to TCU, MR to TCD; see Figure 11	$V_{CC}=2.0V$	-	74	285	ns		
			$V_{CC}=4.5V$	-	27	57	ns		
			$V_{CC}=6.0V$	-	22	48	ns		
		Dn to TCU, Dn to TCD; see Figure 11	$V_{CC}=2.0V$	-	80	290	ns		
			$V_{CC}=4.5V$	-	29	58	ns		
			$V_{CC}=6.0V$	-	23	49	ns		
		HIGH to LOW output transition time	t_{THL}	see Figure 9	$V_{CC}=2.0V$	-	19	75	ns
					$V_{CC}=4.5V$	-	7	15	ns
					$V_{CC}=6.0V$	-	6	13	ns
		LOW to HIGH output transition time	t_{TLH}	see Figure 9	$V_{CC}=2.0V$	-	19	75	ns
					$V_{CC}=4.5V$	-	7	15	ns
					$V_{CC}=6.0V$	-	6	13	ns



深圳市灵星芯微电子科技有限公司

Shenzhen Lingxing Microelectronics Technology Co., Ltd.

版次: B1

编号: SN74HC/HCT193-LX-A193

pulse width	t_w	CPU, CPD (HIGH or LOW);	$V_{CC}=2.0V$	100	22	-	ns
			$V_{CC}=4.5V$	20	8	-	ns
		see Figure 6	$V_{CC}=6.0V$	17	6	-	ns
		MR (HIGH); see Figure 9	$V_{CC}=2.0V$	100	25	-	ns
			$V_{CC}=4.5V$	20	9	-	ns
			$V_{CC}=6.0V$	17	7	-	ns
		$\bar{P}L$ (LOW); see Figure 8	$V_{CC}=2.0V$	100	19	-	ns
			$V_{CC}=4.5V$	20	7	-	ns
$V_{CC}=6.0V$	17		6	-	ns		
recovery time	t_{rec}	$\bar{P}L$ to CPU, CPD; see Figure 8	$V_{CC}=2.0V$	50	8	-	ns
			$V_{CC}=4.5V$	10	3	-	ns
			$V_{CC}=6.0V$	9	2	-	ns
		MR to CPU, CPD; see Figure 9	$V_{CC}=2.0V$	50	0	-	ns
			$V_{CC}=4.5V$	10	0	-	ns
			$V_{CC}=6.0V$	9	0	-	ns
set-up time	t_{su}	Dn to $\bar{P}L$; see Figure 10; note: CPU = CPD = HIGH	$V_{CC}=2.0V$	80	22	-	ns
			$V_{CC}=4.5V$	16	8	-	ns
			$V_{CC}=6.0V$	14	6	-	ns
hold time	t_h	Dn to $\bar{P}L$; see Figure 10	$V_{CC}=2.0V$	0	-14	-	ns
			$V_{CC}=4.5V$	0	-5	-	ns
			$V_{CC}=6.0V$	0	-4	-	ns
		CPU to CPD, CPD to CPU; see Figure 12	$V_{CC}=2.0V$	80	22	-	ns
			$V_{CC}=4.5V$	16	8	-	ns
			$V_{CC}=6.0V$	8	6	-	ns
maximum frequency	f_{max}	CPU, CPD; see Figure 6	$V_{CC}=2.0V$	4.0	13.5	-	MHz
			$V_{CC}=4.5V$	20	41	-	MHz
			$V_{CC}=6.0V$	24	49	-	MHz
power dissipation capacitance	C_{PD}	$V_I=GND$ to V_{CC} ; $V_{CC}=5V$; $f_i=1MHz$	-	24	-	-	pF
SN74HCT193							
propagation delay	t_{pd}	CPU, CPD to Q_n ; see Figure 6	$V_{CC}=4.5V$	-	23	43	ns
		CPU to $\bar{T}C\bar{U}$; see Figure 7	$V_{CC}=4.5V$	-	15	27	ns
		CPD to $\bar{T}C\bar{D}$; see Figure 7	$V_{CC}=4.5V$	-	15	27	ns
		$\bar{P}L$ to Q_n ; see Figure 8	$V_{CC}=4.5V$	-	26	46	ns
		MR to Q_n ; see Figure 9	$V_{CC}=4.5V$	-	22	40	ns
		Dn to Q_n ; see Figure 8	$V_{CC}=4.5V$	-	27	46	ns
		$\bar{P}L$ to $\bar{T}C\bar{U}$, $\bar{P}L$ to $\bar{T}C\bar{D}$; see Figure 11	$V_{CC}=4.5V$	-	31	55	ns



深圳市灵星芯微电子科技有限公司

Shenzhen Lingxing Microelectronics Technology Co., Ltd.

版次: B1

编号: SN74HC/HCT193-LX-A193

		MR to TCU, MR to TCD; see Figure 11	V _{CC} =4.5V	-	29	55	ns
		Dn to TCU, Dn to TCD; see Figure 11	V _{CC} =4.5V	-	32	58	ns
HIGH to LOW output transition time	t _{THL}	see Figure 9; V _{CC} =4.5V		-	7	15	ns
LOW to HIGH output transition time	t _{TLH}	see Figure 9; V _{CC} =4.5V		-	7	15	ns
pulse width	t _w	V _{CC} =4.5V	CPU, CPD (HIGH or LOW); see Figure 6	25	11	-	ns
			MR (HIGH); see Figure 9	20	7	-	ns
			PL (LOW); see Figure 8	20	8	-	ns
recovery time	t _{rec}	V _{CC} =4.5V	PL to CPU, CPD; see Figure 8	10	2	-	ns
			MR to CPU, CPD; see Figure 9	10	0	-	ns
set-up time	t _{su}	Dn to PL; see Figure 10; note: CPU = CPD = HIGH; V _{CC} =4.5V		16	8	-	ns
hold time	t _h	V _{CC} =4.5V	Dn to PL; see Figure 10	0	-6	-	ns
			CPU to CPD, CPD to CPU; see Figure 12	16	7	-	ns
maximum frequency	f _{max}	CPU, CPD; see Figure 6; V _{CC} =4.5V		20	43	-	MHz
power dissipation capacitance	C _{PD}	per monostable; V _I =GND to V _{CC} -1.5V		-	26	-	pF

Note:

[1] t_{pd} is the same as t_{PLH} and t_{PHL}.

[2] C_{PD} is used to determine the dynamic power dissipation (P_D in uW).

$$P_D = C_{PD} \times V_{CC}^2 \times f_i \times N + \sum (C_L \times V_{CC}^2 \times f_o)$$
 where:

f_i=input frequency in MHz;

f_o=output frequency in MHz;

C_L=output load capacitance in pF;

V_{CC}=supply voltage in V;

N=number of inputs switching;

∑(C_L×V_{CC}²×f_o)=sum of outputs.



3.3.5 、 AC Characteristics 2

($T_{amb}=-40^{\circ}C$ to $+85^{\circ}C$, voltages are referenced to GND (ground=0V), unless otherwise specified.)

Parameter	Symbol	Conditions	Min.	Typ.	Max.	Unit	
SN74HC193							
propagation delay	t_{pd}	CPU, CPD to Qn; see Figure 6	$V_{CC}=2.0V$	-	-	270	ns
			$V_{CC}=4.5V$	-	-	54	ns
			$V_{CC}=6.0V$	-	-	46	ns
		CPU to TCU; see Figure 7	$V_{CC}=2.0V$	-	-	155	ns
			$V_{CC}=4.5V$	-	-	31	ns
			$V_{CC}=6.0V$	-	-	26	ns
		CPD to TCD; see Figure 7	$V_{CC}=2.0V$	-	-	155	ns
			$V_{CC}=4.5V$	-	-	31	ns
			$V_{CC}=6.0V$	-	-	26	ns
		PL to Qn; see Figure 8	$V_{CC}=2.0V$	-	-	275	ns
			$V_{CC}=4.5V$	-	-	55	ns
			$V_{CC}=6.0V$	-	-	47	ns
		MR to Qn; see Figure 9	$V_{CC}=2.0V$	-	-	250	ns
			$V_{CC}=4.5V$	-	-	50	ns
			$V_{CC}=6.0V$	-	-	43	ns
		Dn to Qn; see Figure 8	$V_{CC}=2.0V$	-	-	265	ns
			$V_{CC}=4.5V$	-	-	53	ns
			$V_{CC}=6.0V$	-	-	45	ns
		PL to TCU, PL to TCD; see Figure 11	$V_{CC}=2.0V$	-	-	365	ns
			$V_{CC}=4.5V$	-	-	73	ns
			$V_{CC}=6.0V$	-	-	62	ns
		MR to TCU, MR to TCD; see Figure 11	$V_{CC}=2.0V$	-	-	355	ns
			$V_{CC}=4.5V$	-	-	71	ns
			$V_{CC}=6.0V$	-	-	60	ns
Dn to TCU, Dn to TCD; see Figure 11	$V_{CC}=2.0V$	-	-	365	ns		
	$V_{CC}=4.5V$	-	-	73	ns		
	$V_{CC}=6.0V$	-	-	62	ns		
HIGH to LOW output transition time	t_{THL}	see Figure 9	$V_{CC}=2.0V$	-	-	95	ns
			$V_{CC}=4.5V$	-	-	19	ns
			$V_{CC}=6.0V$	-	-	16	ns
LOW to HIGH output transition time	t_{TLH}	see Figure 9	$V_{CC}=2.0V$	-	-	95	ns
			$V_{CC}=4.5V$	-	-	19	ns
			$V_{CC}=6.0V$	-	-	16	ns
pulse width	t_w	CPU, CPD (HIGH or LOW); see Figure 6	$V_{CC}=2.0V$	125	-	-	ns
			$V_{CC}=4.5V$	25	-	-	ns
			$V_{CC}=6.0V$	21	-	-	ns
		MR (HIGH); see Figure 9	$V_{CC}=2.0V$	125	-	-	ns
			$V_{CC}=4.5V$	25	-	-	ns
			$V_{CC}=6.0V$	21	-	-	ns
		-	$V_{CC}=2.0V$	125	-	-	ns



深圳市灵星芯微电子科技有限公司

Shenzhen Lingxing Microelectronics Technology Co., Ltd.

版次: B1

编号: SN74HC/HCT193-LX-A193

		PL (LOW); see Figure 8	V _{CC} =4.5V	25	-	-	ns
			V _{CC} =6.0V	21	-	-	ns
recovery time	t _{rec}	PL to CPU, CPD; see Figure 8	V _{CC} =2.0V	65	-	-	ns
			V _{CC} =4.5V	13	-	-	ns
			V _{CC} =6.0V	11	-	-	ns
		MR to CPU, CPD; see Figure 9	V _{CC} =2.0V	65	-	-	ns
			V _{CC} =4.5V	13	-	-	ns
			V _{CC} =6.0V	11	-	-	ns
set-up time	t _{su}	Dn to PL; see Figure 10; note: CPU = CPD = HIGH	V _{CC} =2.0V	100	-	-	ns
			V _{CC} =4.5V	20	-	-	ns
			V _{CC} =6.0V	17	-	-	ns
hold time	t _h	Dn to PL; see Figure 10	V _{CC} =2.0V	0	-	-	ns
			V _{CC} =4.5V	0	-	-	ns
			V _{CC} =6.0V	0	-	-	ns
		CPU to CPD, CPD to CPU; see Figure 12	V _{CC} =2.0V	100	-	-	ns
			V _{CC} =4.5V	20	-	-	ns
			V _{CC} =6.0V	17	-	-	ns
maximum frequency	f _{max}	CPU, CPD; see Figure 6	V _{CC} =2.0V	3.2	-	-	MHz
			V _{CC} =4.5V	16	-	-	MHz
			V _{CC} =6.0V	19	-	-	MHz
SN74HCT193							
propagation delay	t _{pd}	CPU, CPD to Qn; see Figure 6	V _{CC} =4.5V	-	-	54	ns
		CPU to TCU; see Figure 7	V _{CC} =4.5V	-	-	34	ns
		CPD to TCD; see Figure 7	V _{CC} =4.5V	-	-	34	ns
		PL to Qn; see Figure 8	V _{CC} =4.5V	-	-	58	ns
		MR to Qn; see Figure 9	V _{CC} =4.5V	-	-	50	ns
		Dn to Qn; see Figure 8	V _{CC} =4.5V	-	-	58	ns
		PL to TCU, PL to TCD; see Figure 11	V _{CC} =4.5V	-	-	69	ns
		MR to TCU, MR to TCD; see Figure 11	V _{CC} =4.5V	-	-	69	ns
		Dn to TCU, Dn to TCD; see Figure 11	V _{CC} =4.5V	-	-	73	ns
HIGH to LOW output transition time	t _{THL}	see Figure 9; V _{CC} =4.5V		-	-	19	ns
LOW to HIGH output transition time	t _{TLH}	see Figure 9; V _{CC} =4.5V		-	-	19	ns



深圳市灵星芯微电子科技有限公司

Shenzhen Lingxing Microelectronics Technology Co., Ltd.

版次: B1

编号: SN74HC/HCT193-LX-A193

pulse width	t _w	V _{CC} =4.5V	CPU, CPD (HIGH or LOW); see Figure 6	31	-	-	ns
			MR (HIGH);	25	-	-	ns
			see Figure 9				
			PL (LOW); see Figure 8	25	-	-	ns
recovery time	t _{rec}	V _{CC} =4.5V	PL to CPU, CPD; see Figure 8	13	-	-	ns
			MR to CPU, CPD; see Figure 9	13	-	-	ns
set-up time	t _{su}	Dn to PL; see Figure 10; note: CPU = CPD = HIGH; V _{CC} =4.5V		20	-	-	ns
hold time	t _h	V _{CC} =4.5V	Dn to PL; see Figure 10	0	-	-	ns
			CPU to CPD, CPD to CPU; see Figure 12	20	-	-	ns
maximum frequency	f _{max}	CPU, CPD; see Figure 6; V _{CC} =4.5V		16	-	-	MHz

Note:

[1] t_{pd} is the same as t_{PLH} and t_{PHL}.

3.3.6 AC Characteristics 3

(T_{amb}=-40°C to +105°C, voltages are referenced to GND (ground=0V), unless otherwise specified.)

Parameter	Symbol	Conditions	Min.	Typ.	Max.	Unit	
SN74HC193							
propagation delay	t _{pd}	CPU, CPD to Qn; see Figure 6	V _{CC} =2.0V	-	-	325	ns
			V _{CC} =4.5V	-	-	65	ns
			V _{CC} =6.0V	-	-	55	ns
		CPU to TCU; see Figure 7	V _{CC} =2.0V	-	-	190	ns
			V _{CC} =4.5V	-	-	38	ns
			V _{CC} =6.0V	-	-	32	ns
		CPD to TCD; see Figure 7	V _{CC} =2.0V	-	-	190	ns
			V _{CC} =4.5V	-	-	38	ns
			V _{CC} =6.0V	-	-	32	ns
		PL to Qn; see Figure 8	V _{CC} =2.0V	-	-	330	ns
			V _{CC} =4.5V	-	-	66	ns
			V _{CC} =6.0V	-	-	56	ns
		MR to Qn; see Figure 9	V _{CC} =2.0V	-	-	300	ns
			V _{CC} =4.5V	-	-	60	ns
			V _{CC} =6.0V	-	-	51	ns
		Dn to Qn; see Figure 8	V _{CC} =2.0V	-	-	315	ns
			V _{CC} =4.5V	-	-	63	ns
			V _{CC} =6.0V	-	-	54	ns
PL to TCU, PL to TCD; see Figure 11	V _{CC} =2.0V	-	-	435	ns		
	V _{CC} =4.5V	-	-	87	ns		
	V _{CC} =6.0V	-	-	74	ns		



深圳市灵星芯微电子科技有限公司

Shenzhen Lingxing Microelectronics Technology Co., Ltd.

版次: B1

编号: SN74HC/HCT193-LX-A193

		MR to $\overline{\text{TCU}}$, MR to $\overline{\text{TCD}}$; see Figure 11	$V_{CC}=2.0V$	-	-	430	ns
			$V_{CC}=4.5V$	-	-	86	ns
			$V_{CC}=6.0V$	-	-	73	ns
		Dn to $\overline{\text{TCU}}$, Dn to $\overline{\text{TCD}}$; see Figure 11	$V_{CC}=2.0V$	-	-	435	ns
			$V_{CC}=4.5V$	-	-	87	ns
			$V_{CC}=6.0V$	-	-	74	ns
HIGH to LOW output transition time	t_{THL}	see Figure 9	$V_{CC}=2.0V$	-	-	110	ns
			$V_{CC}=4.5V$	-	-	22	ns
			$V_{CC}=6.0V$	-	-	19	ns
LOW to HIGH output transition time	t_{TLH}	see Figure 9	$V_{CC}=2.0V$	-	-	110	ns
			$V_{CC}=4.5V$	-	-	22	ns
			$V_{CC}=6.0V$	-	-	19	ns
pulse width	t_w	CPU, CPD (HIGH or LOW); see Figure 6	$V_{CC}=2.0V$	150	-	-	ns
			$V_{CC}=4.5V$	30	-	-	ns
			$V_{CC}=6.0V$	26	-	-	ns
		MR (HIGH); see Figure 9	$V_{CC}=2.0V$	150	-	-	ns
			$V_{CC}=4.5V$	30	-	-	ns
			$V_{CC}=6.0V$	26	-	-	ns
		$\overline{\text{PL}}$ (LOW); see Figure 8	$V_{CC}=2.0V$	150	-	-	ns
			$V_{CC}=4.5V$	30	-	-	ns
			$V_{CC}=6.0V$	26	-	-	ns
recovery time	t_{rec}	$\overline{\text{PL}}$ to CPU, CPD; see Figure 8	$V_{CC}=2.0V$	75	-	-	ns
			$V_{CC}=4.5V$	15	-	-	ns
			$V_{CC}=6.0V$	13	-	-	ns
		MR to CPU, CPD; see Figure 9	$V_{CC}=2.0V$	75	-	-	ns
			$V_{CC}=4.5V$	15	-	-	ns
			$V_{CC}=6.0V$	13	-	-	ns
set-up time	t_{su}	Dn to $\overline{\text{PL}}$; see Figure 10; note: CPU = CPD = HIGH	$V_{CC}=2.0V$	120	-	-	ns
			$V_{CC}=4.5V$	24	-	-	ns
			$V_{CC}=6.0V$	20	-	-	ns
hold time	t_h	Dn to $\overline{\text{PL}}$; see Figure 10	$V_{CC}=2.0V$	0	-	-	ns
			$V_{CC}=4.5V$	0	-	-	ns
			$V_{CC}=6.0V$	0	-	-	ns
		CPU to CPD, CPD to CPU; see Figure 12	$V_{CC}=2.0V$	120	-	-	ns
			$V_{CC}=4.5V$	24	-	-	ns
			$V_{CC}=6.0V$	20	-	-	ns
maximum frequency	f_{max}	CPU, CPD; see Figure 6	$V_{CC}=2.0V$	2.6	-	-	MHz
			$V_{CC}=4.5V$	13	-	-	MHz
			$V_{CC}=6.0V$	15	-	-	MHz
SN74HCT193							
		CPU, CPD to Qn; see Figure 6	$V_{CC}=4.5V$	-	-	65	ns
		CPU to $\overline{\text{TCU}}$; see Figure 7	$V_{CC}=4.5V$	-	-	41	ns



深圳市灵星芯微电子科技有限公司

Shenzhen Lingxing Microelectronics Technology Co., Ltd.

版次: B1

编号: SN74HC/HCT193-LX-A193

propagation delay	t_{pd}	CPD to TCD; see Figure 7	$V_{CC}=4.5V$	-	-	41	ns
		PL to Qn; see Figure 8	$V_{CC}=4.5V$	-	-	69	ns
		MR to Qn; see Figure 9	$V_{CC}=4.5V$	-	-	60	ns
		Dn to Qn; see Figure 8	$V_{CC}=4.5V$	-	-	69	ns
		PL to TCU, PL to TCD; see Figure 11	$V_{CC}=4.5V$	-	-	83	ns
		MR to TCU, MR to TCD; see Figure 11	$V_{CC}=4.5V$	-	-	83	ns
		Dn to TCU, Dn to TCD; see Figure 11	$V_{CC}=4.5V$	-	-	87	ns
HIGH to LOW output transition time	t_{THL}	see Figure 9; $V_{CC}=4.5V$		-	-	22	ns
LOW to HIGH output transition time	t_{TLH}	see Figure 9; $V_{CC}=4.5V$		-	-	22	ns
pulse width	t_w	$V_{CC}=4.5V$	CPU, CPD (HIGH or LOW); see Figure 6	38	-	-	ns
			MR (HIGH); see Figure 9	30	-	-	ns
			PL (LOW); see Figure 8	30	-	-	ns
recovery time	t_{rec}	$V_{CC}=4.5V$	PL to CPU, CPD; see Figure 8	15	-	-	ns
			MR to CPU, CPD; see Figure 9	15	-	-	ns
set-up time	t_{su}	Dn to PL; see Figure 10; note: CPU = CPD = HIGH; $V_{CC}=4.5V$		24	-	-	ns
hold time	t_h	$V_{CC}=4.5V$	Dn to PL; see Figure 10	0	-	-	ns
			CPU to CPD, CPD to CPU; see Figure 12	24	-	-	ns
maximum frequency	f_{max}	CPU, CPD; see Figure 6; $V_{CC}=4.5V$		13	-	-	MHz

Note:

[1] t_{pd} is the same as t_{PLH} and t_{PHL} .



4、Testing Circuit

4.1、AC Testing Circuit

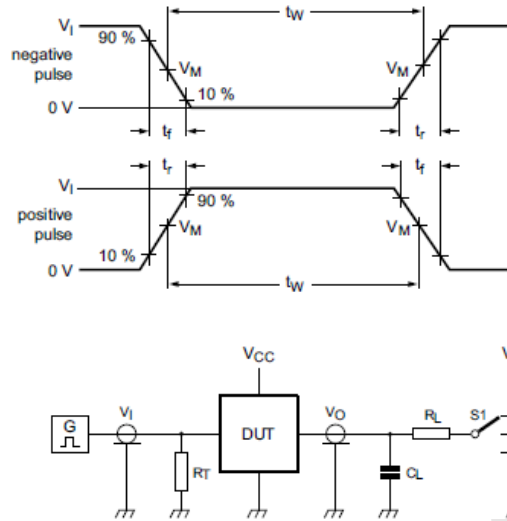

Figure 5. Test circuit for measuring switching times

Definitions for test circuit:

R_L =Load resistance.

C_L =Load capacitance including jig and probe capacitance.

R_T =Termination resistance should be equal to the output impedance Z_o of the pulse generator.

S1=Test selection switch.

4.2、AC Testing Waveforms

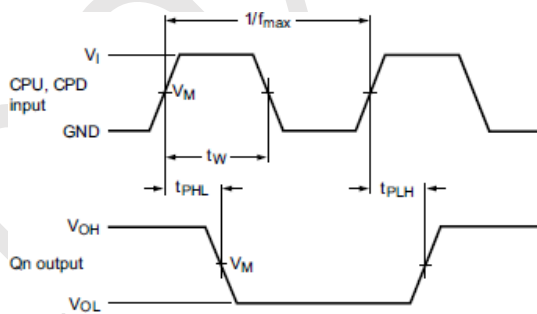

Figure 6. The clock (CPU, CPD) to output (Qn) propagation delays, the clock pulse width, and the maximum clock pulse frequency

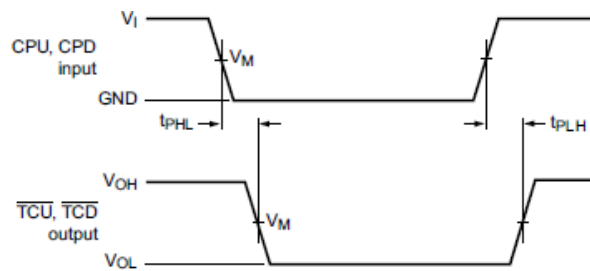

Figure 7. The clock (CPU, CPD) to terminal count output (TCU, TCD) propagation delays

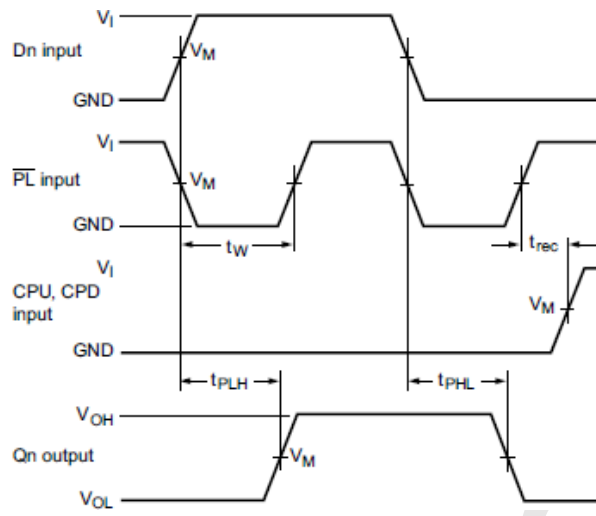

Figure 8. The parallel load input (PL) and data (Dn) to Qn output propagation delays and PL removal time to clock input (CPU, CPD)

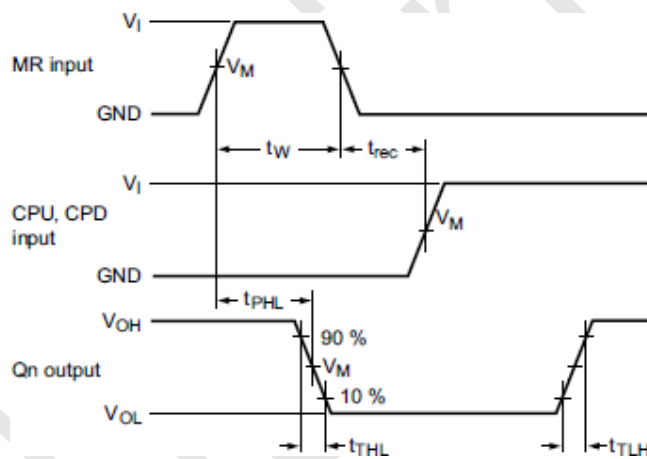

Figure 9. The master reset input (MR) pulse width, MR to Qn propagation delays, MR to CPU, CPD removal time and output transition times

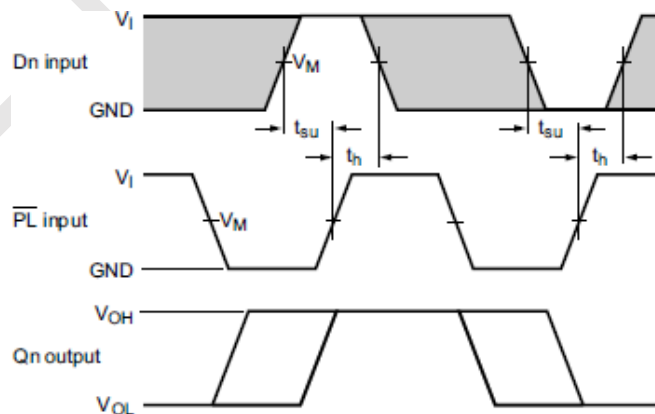



Figure 10. The data input (Dn) to parallel load input (PL) set-up and hold times

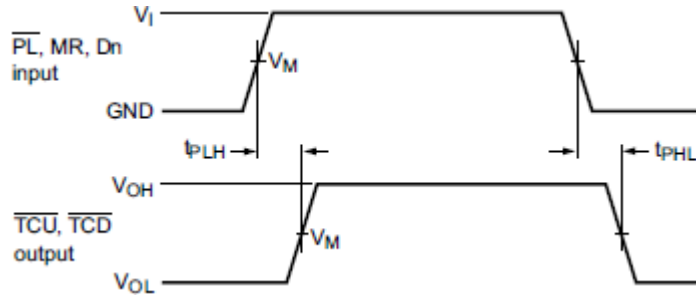

Figure 11. The data input (Dn), parallel load input (PL) and the master reset input (MR) to the terminal count outputs (TCU, TCD) propagation delays

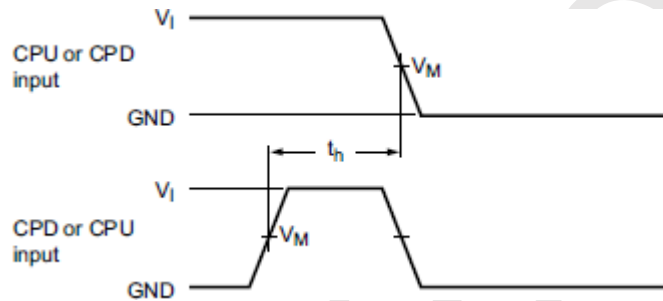

Figure 12. The CPU to CPD or CPD to CPU hold times

4.3 、 Measurement Points

Type	Input		Output
	V_I	V_M	V_M
SN74HC193	GND to V_{CC}	$0.5 \times V_{CC}$	$0.5 \times V_{CC}$
SN74HCT193	GND to 3V	1.3V	1.3V

4.4 、 Test Data

Type	Input		Load		S1 position
	V_I	t_r, t_f	C_L	R_L	t_{PHL}, t_{PLH}
SN74HC193	V_{CC}	6ns	15pF, 50pF	1k Ω	open
SN74HCT193	3V	6ns	15pF, 50pF	1k Ω	open



5、Package Information

5.1、DIP16

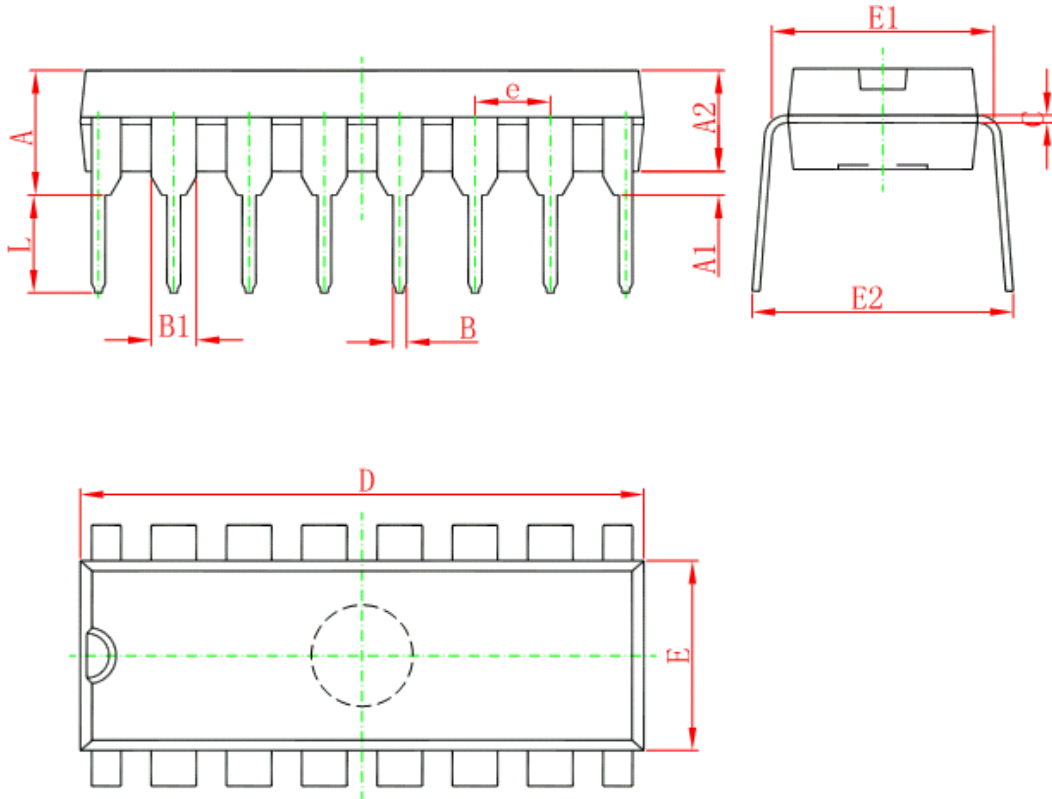

Symbol	Dimensions In Millimeters		Dimensions In Inches	
	Min	Max	Min	Max
A	3.710	4.310	0.146	0.170
A1	0.510		0.020	
A2	3.200	3.600	0.126	0.142
B	0.380	0.570	0.015	0.022
B1	1.524 (BSC)		0.060 (BSC)	
C	0.204	0.360	0.008	0.014
D	18.800	19.200	0.740	0.756
E	6.200	6.600	0.244	0.260
E1	7.320	7.920	0.288	0.312
e	2.540 (BSC)		0.100 (BSC)	
L	3.000	3.600	0.118	0.142
E2	8.400	9.000	0.331	0.354



5.2、SOP16

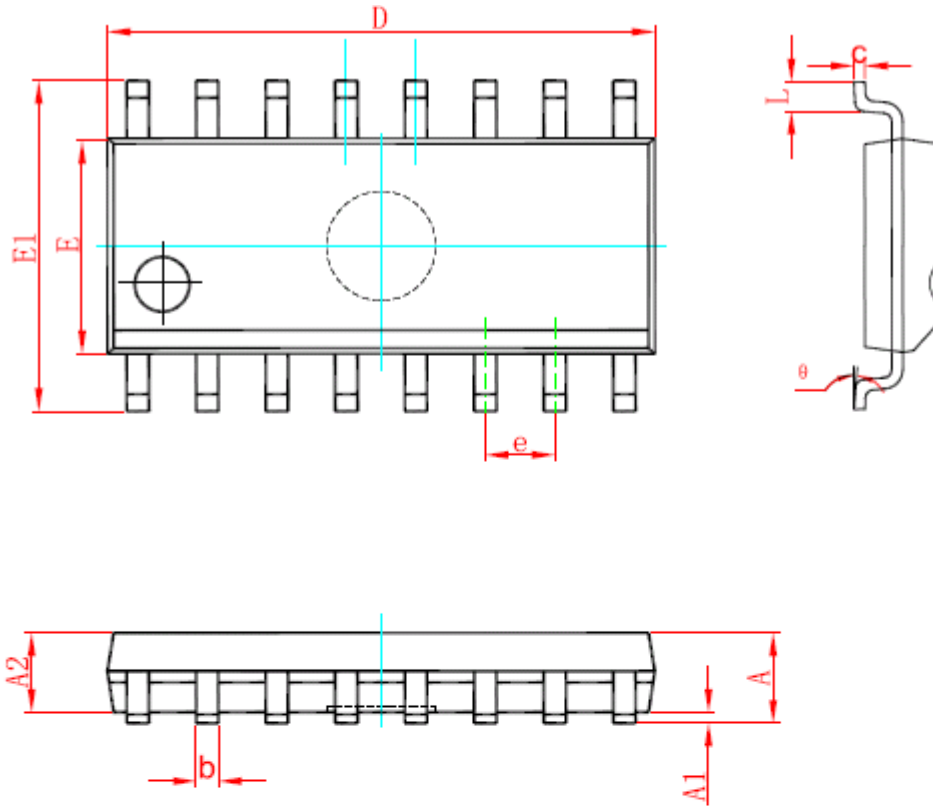

Symbol	Dimensions In Millimeters		Dimensions In Inches	
	Min	Max	Min	Max
A	1.350	1.750	0.053	0.069
A1	0.100	0.250	0.004	0.010
A2	1.350	1.550	0.053	0.061
b	0.330	0.510	0.013	0.020
c	0.170	0.250	0.007	0.010
D	9.800	10.200	0.386	0.402
E	3.800	4.000	0.150	0.157
E1	5.800	6.200	0.228	0.244
e	1.270 (BSC)		0.050 (BSC)	
L	0.400	1.270	0.016	0.050
θ	0°	8°	0°	8°



5.3、TSSOP16

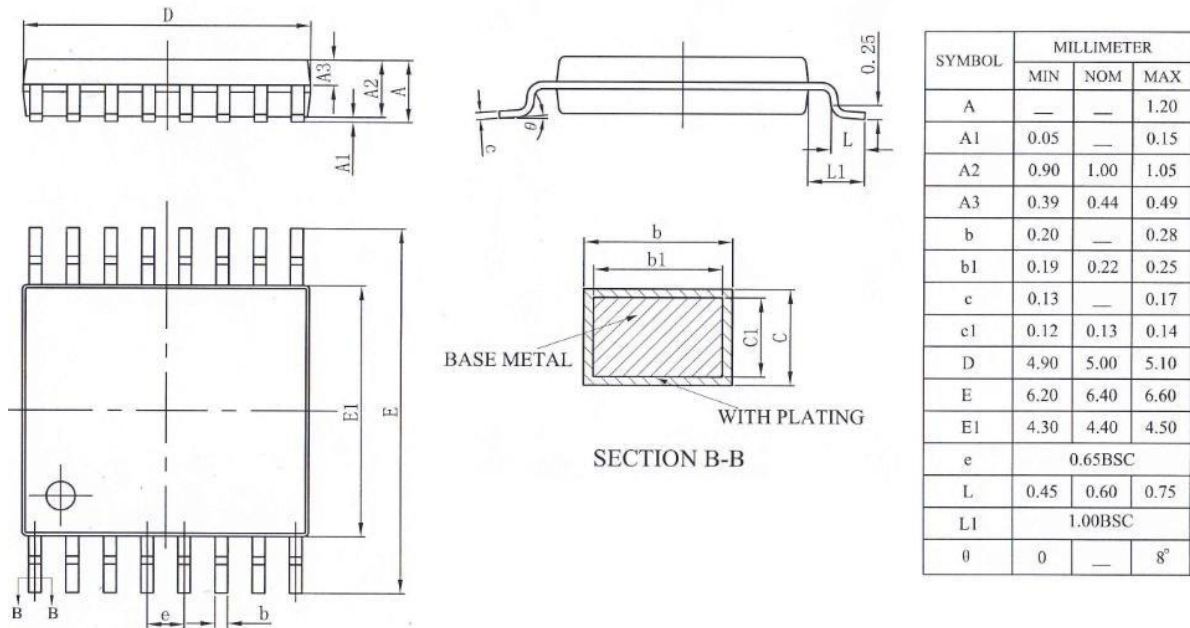

6、Statements And Notes

6.1、The name and content of Hazardous substances or Elements in the product

Part name	Hazardous substances or Elements									
	Lead and lead compounds	Mercury and mercury compounds	Cadmium and cadmium compounds	Hexavalent chromium compounds	Polybrominated biphenyls	Polybrominated biphenyl ethers	Dibutyl phthalate	Butylbenzyl phthalate	Di-2-ethylhexyl phthalate	Diisobutyl phthalate
Lead frame	○	○	○	○	○	○	○	○	○	○
Plastic resin	○	○	○	○	○	○	○	○	○	○
Chip	○	○	○	○	○	○	○	○	○	○
The lead	○	○	○	○	○	○	○	○	○	○
Plastic sheet installed	○	○	○	○	○	○	○	○	○	○
explanation	○: Indicates that the content of hazardous substances or elements in the detection limit of the following the SJ/T11363-2006 standard. ×: Indicates that the content of hazardous substances or elements exceeding the SJ/T11363-2006 Standard limit requirements.									

6.2、Notion

Recommended carefully reading this information before the use of this product;

The information in this document are subject to change without notice;

This information is using to the reference only, the company is not responsible for any loss;

The company is not responsible for the any infringement of the third party patents or other rights of the responsibility.

X-ON Electronics

Largest Supplier of Electrical and Electronic Components

Click to view similar products for [Counter ICs](#) category:

Click to view products by [lingxingic](#) manufacturer:

Other Similar products are found below :

[CD4018BE](#) [CD4033BE](#) [CD4060BE](#) [CD4040BE](#) [NLV14040BDR2G](#) [RFDIP1607ALM9T21](#) [RFDIP1606L708D1T](#) [RFTIP2510T12A8Q1C](#)
[74HC161DT](#) [CD4028BM/TR](#) [CD4060DM/TR](#) [CD4022BE](#) [CD4060DMT/TR](#) [CD4060BMT/TR](#) [74HC192M/TR](#) [CD4020BMT/TR](#)
[74HC193M/TR](#) [CD4518BM/TR](#) [CD4060TA16.TB](#) [CD4060DE](#) [CD4017CN](#) [CD4017SA.TB](#) [CD4022BM/TR](#) [CD4022BMT/TR](#)
[CD4028BDRG](#) [CD4060BDRG](#) [CD4017DA.TB](#) [CD4520BDRG](#) [CD4520BM\(LX\)](#) [CD4518BM\(LX\)](#) [SN74HC393DR\(LX\)](#) [CD4060BM\(LX\)](#)
[CD4060BE\(LX\)](#) [SN74HC192N\(XBLW\)](#) [CD4040BM\(LX\)](#) [CD4026BM\(LX\)](#) [CD40103BDR\(LX\)](#) [SN74LS192DR\(LX\)](#) [SN74HC161DR \(LX\)](#)
[CD40193BE\(LX\)](#) [CD4060BDTR\(XBLW\)](#) [SN74LS393DR](#) [SN74LS193N\(LX\)](#) [SN74LS193DR\(LX\)](#) [CD4017BM\(LX\)](#) [CD40193BM\(LX\)](#)
[SN74LS192N\(LX\)](#) [SN74LS160N\(LX\)](#) [SN74LS161N\(LX\)](#) [CD4024BM\(LX\)](#)