



# SN74HC/HCT194 (LX) 4-bit Bidirectional Universal Shift Register

## Product Specification

### Specification Revision History:

Version	Date	Description
2023-05-A1	2023-05	New



# Contents

<b>1、 General Description.....</b>	<b>3</b>
<b>2、 Block Diagram And Pin Description .....</b>	<b>5</b>
2.1、 Block Diagram .....	5
2.2、 Pin Configurations.....	5
2.3、 Pin Description .....	6
<b>3、 Electrical Parameter .....</b>	<b>7</b>
3.1、 Absolute Maximum Ratings.....	7
3.2、 Recommended Operating Conditions .....	7
3.3、 Electrical Characteristics .....	7
3.3.1、 DC Characteristics 1 .....	7
3.3.2、 DC Characteristics 2 .....	8
3.3.3、 AC Characteristics 1 .....	9
3.3.4、 AC Characteristics 2 .....	11
<b>4、 Testing Circuit .....</b>	<b>13</b>
4.1、 AC Testing Circuit .....	13
4.2、 Test Data .....	13
4.3、 AC Testing Waveforms.....	14
4.4、 Measurement Points .....	15
<b>5、 Package Information .....</b>	<b>16</b>
5.1、 DIP16 .....	16
5.2、 SOP16 .....	17
5.3、 TSSOP16.....	18
<b>6、 Statements And Notes .....</b>	<b>19</b>
6.1、 The name and content of Hazardous substances or Elements in the product.....	19
6.2、 Notes .....	19



## 1、General Description

The SN74HC/HCT194 is a 4-bit bidirectional universal shift register.

### Features:

- Supply voltage range:  
SN74HC194: 2V to 6V  
SN74HCT194: 4.5V to 5.5V
- Input levels:  
SN74HC194: CMOS level  
SN74HCT194: TTL level
- Temperature range: -40°C to +125°C
- Packaging information: DIP16/SOP16/TSSOP16

### Ordering Information:

#### Tube packing specifications:

Part number	Packaging form	Marking code	Tube quantity	Boxed tube quantity	Boxed quantity	Notes
SN74HC194N (LX)	DIP16	SN74HC194N	25 PCS/tube	40 tube/box	1000 PCS/box	Dimensions of plastic enclosure: 19.0mm×6.4mm Pin spacing: 2.54mm
SN74HCT194N (LX)	DIP16	74HCT194	25 PCS/tube	40 tube/box	1000 PCS/box	Dimensions of plastic enclosure: 19.0mm×6.4mm Pin spacing: 2.54mm
SN74HC194D (LX)	SOP16	SN74HC194	50 PCS/tube	200 tube/box	10000 PCS/box	Dimensions of plastic enclosure: 10.0mm×3.9mm Pin spacing: 1.27mm
SN74HCT194D (LX)	SOP16	HCT194	50 PCS/tube	200 tube/box	10000 PCS/box	Dimensions of plastic enclosure: 10.0mm×3.9mm Pin spacing: 1.27mm
SN74HC194P (LX)	TSSOP16	74HC194	96 PCS/tube	200 tube/box	19200 PCS/box	Dimensions of plastic enclosure: 5.0mm×4.4mm Pin spacing: 0.65mm
SN74HCT194P (LX)	TSSOP16	74HCT194	96 PCS/tube	200 tube/box	19200 PCS/box	Dimensions of plastic enclosure: 5.0mm×4.4mm Pin spacing: 0.65mm



**Reel packing specifications:**

Part number	Packaging form	Marking code	Reel quantity	Boxed reel quantity	Notes
SN74HC194DR (LX)	SOP16	SN74HC194	4000 PCS/reel	8000 PCS/box	Dimensions of plastic enclosure: 10.0mm×3.9mm Pin spacing: 1.27mm
SN74HCT194DR (LX)	SOP16	74HCT194	4000 PCS/reel	8000 PCS/box	Dimensions of plastic enclosure: 10.0mm×3.9mm Pin spacing: 1.27mm
SN74HC194PW (LX)	TSSOP16	74HC194	5000 PCS/reel	10000 PCS/box	Dimensions of plastic enclosure: 5.0mm×4.4mm Pin spacing: 0.65mm
SN74HCT194PW (LX)	TSSOP16	74HCT194	5000 PCS/reel	10000 PCS/box	Dimensions of plastic enclosure: 5.0mm×4.4mm Pin spacing: 0.65mm

Note: If the physical information is inconsistent with the ordering information, please refer to the actual product.





## 2、Block Diagram And Pin Description

### 2.1、Block Diagram

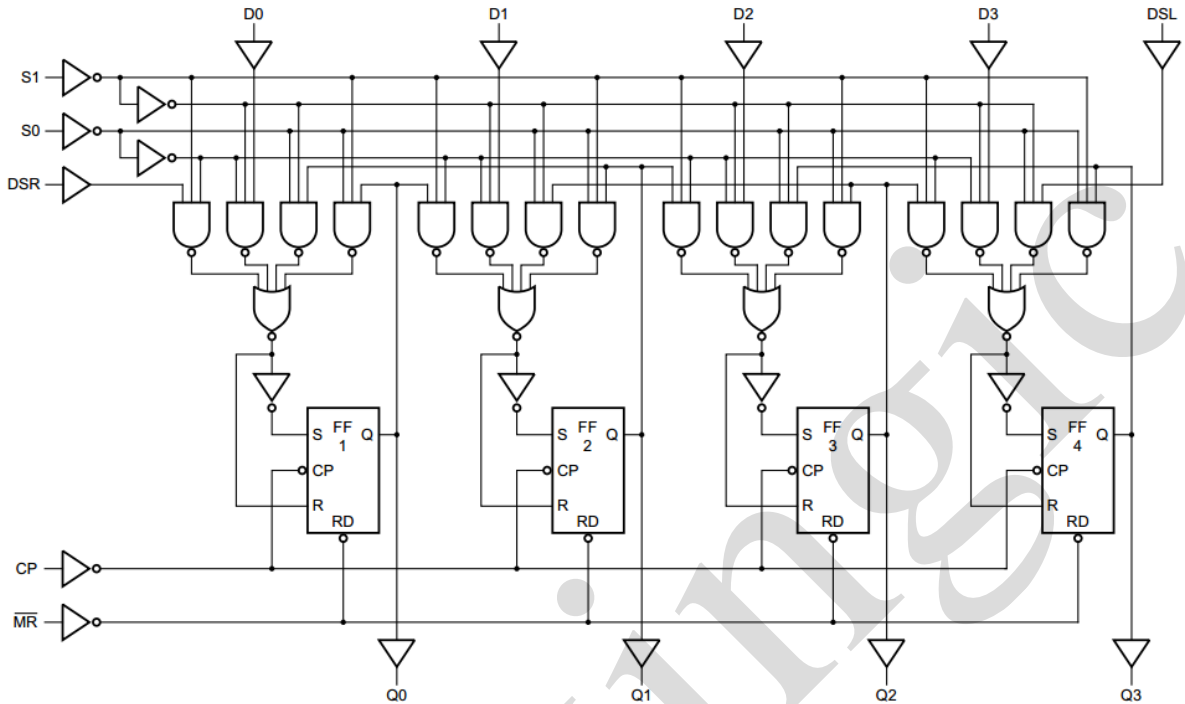

Figure 1. Logic symbol

### 2.2、Pin Configurations

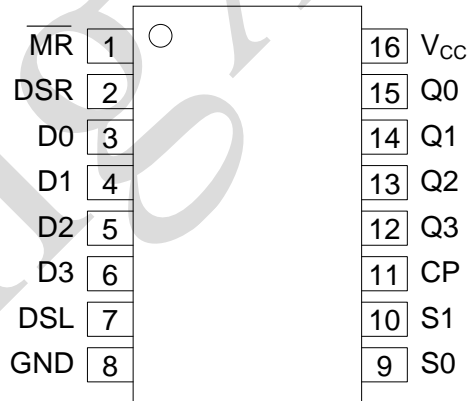

Figure 2. Pin configurations



### 2.3、Pin Description

Pin No.	Pin Name	Description
1	$\overline{\text{MR}}$	Asynchronous master reset input(active low)
2	DSR	serious data input(shift right)
3	D0	parallel data input
4	D1	parallel data input
5	D2	parallel data input
6	D3	parallel data input
7	DSL	Serial data input(shift left)
8	GND	ground (0V)
9	S0	mode control input
10	S1	mode control input
11	CP	Clock input(LOW-to-HIGH edge-triggered)
12	Q3	Parallel output
13	Q2	Parallel output
14	Q1	Parallel output
15	Q0	Parallel output
16	V <sub>CC</sub>	supply voltage

### 2.4、Function Table

Operation mode	inputs							Outputs			
	CP	$\overline{\text{MR}}$	S1	S0	DSR	DSL	Dn	Q0	Q1	Q2	Q3
reset(clear)	X	L	X	X	X	X	X	L	L	L	L
Hold(do nothing)	X	H	l	l	X	X	X	Q0	Q1	Q2	Q3
Shift left	↑	H	h	l	X	l	X	Q1	Q2	Q3	L
	↑	H	h	l	X	h	X	Q1	Q2	Q3	H
Shift right	↑	H	l	h	l	X	X	L	Q0	Q1	Q2
	↑	H	l	h	h	X	X	H	Q0	Q1	Q2
Parallel load	↑	H	h	h	X	X	Dn	D0	D1	D2	D3

Note:

H=HIGH voltage level; L=LOW voltage level.

h=HIGH voltage level one set-up time prior to the LOW-to-HIGH CP transition.

l=LOW voltage level one set-up time prior to the LOW-to-HIGH CP transition.

X=don't care.

↑=LOW to HIGH CP transition.



### 3、Electrical Parameter

#### 3.1、Absolute Maximum Ratings

(Voltages are referenced to GND (ground=0V), unless otherwise specified.)

Parameter	Symbol	Conditions	Min.	Max.	Unit
supply voltage	$V_{CC}$	-	-0.5	+7	V
supply current	$I_{CC}$	-	-	50	mA
ground current	$I_{GND}$	-	-50	-	mA
input clamping current	$I_{IK}$	$V_I < -0.5V$ or $V_I > V_{CC} + 0.5V$	-	$\pm 20$	mA
output clamping current	$I_{OK}$	$V_O < -0.5V$ or $V_O > V_{CC} + 0.5V$	-	$\pm 20$	mA
output current	$I_O$	$-0.5V < V_O < V_{CC} + 0.5V$	-	$\pm 25$	mA
storage temperature	$T_{stg}$	-	-65	+150	$^{\circ}C$
soldering temperature	$T_L$	10s	DIP	245	$^{\circ}C$
			SOP/TSSOP	260	

#### 3.2、Recommended Operating Conditions

Parameter	Symbol	Conditions	Min.	Typ.	Max.	Unit
<b>SN74HC194</b>						
supply voltage	$V_{CC}$	-	2.0	5.0	6.0	V
input voltage	$V_I$	-	0	-	$V_{CC}$	V
output voltage	$V_O$	-	0	-	$V_{CC}$	V
ambient temperature	$T_{amb}$	-	-40	-	+125	$^{\circ}C$
<b>SN74HCT194</b>						
supply voltage	$V_{CC}$	-	4.5	5.0	5.5	V
input voltage	$V_I$	-	0	-	$V_{CC}$	V
output voltage	$V_O$	-	0	-	$V_{CC}$	V
ambient temperature	$T_{amb}$	-	-40	-	+125	$^{\circ}C$

#### 3.3、Electrical Characteristics

##### 3.3.1、DC Characteristics 1

( $T_{amb} = -40^{\circ}C$  to  $+85^{\circ}C$ , voltages are referenced to GND (ground=0V), unless otherwise specified.)

Parameter	Symbol	$V_{CC}$	Conditions	Min.	Typ.	Max.	Unit
<b>SN74HC194</b>							
HIGH-level input voltage	$V_{IH}$	2.0V	-	1.5	1.2	-	V
		4.5V	-	3.15	2.4	-	V
		6.0V	-	4.2	3.2	-	V
LOW-level input voltage	$V_{IL}$	2.0V	-	-	0.8	0.5	V
		4.5V	-	-	2.1	1.35	V
		6.0V	-	-	2.8	1.8	V
HIGH-level output voltage	$V_{OH}$	2.0V	$I_O = -20\mu A$	1.9	2.0	-	V
		4.5V	$I_O = -20\mu A$	4.4	4.5	-	V
		6.0V	$I_O = -20\mu A$	5.9	6.0	-	V
		4.5V	$I_O = -4.0mA$	3.84	4.32	-	V
		6.0V	$I_O = -5.2mA$	5.34	5.81	-	V
LOW-level	$V_{OL}$	2.0V	$I_O = 20\mu A$	-	0	0.1	V



output voltage		4.5V	$I_O=20\mu A$	-	0	0.1	V
		6.0V	$I_O=20\mu A$	-	0	0.1	V
		4.5V	$I_O=4.0mA$	-	0.15	0.33	V
		6.0V	$I_O=5.2mA$	-	0.16	0.33	V
input leakage current	$I_I$	6.0V	$V_I=V_{CC}$ or GND	-	-	$\pm 1$	$\mu A$
supply current	$I_{CC}$	6.0V	$V_I=V_{CC}$ or GND; $I_O=0A$	-	-	80	$\mu A$
<b>SN74HC194</b>							
HIGH-level input voltage	$V_{IH}$	4.5V to 5.5V	-	2.0	1.6	-	V
LOW-level input voltage	$V_{IL}$	4.5V to 5.5V	-	-	1.2	0.8	V
HIGH-level output voltage	$V_{OH}$	4.5V	$I_O=-20\mu A$	4.4	4.5	-	V
			$I_O=-4.0mA$	3.84	4.32	-	V
LOW-level output voltage	$V_{OL}$	4.5V	$I_O=20\mu A$	-	0	0.1	V
			$I_O=4.0mA$	-	0.15	0.33	V
input leakage current	$I_I$	5.5V	$V_I=V_{CC}$ or GND	-	-	$\pm 1$	$\mu A$
supply current	$I_{CC}$	6.0V	$V_I=V_{CC}$ or GND; $I_O=0A$	-	-	80	$\mu A$
additional supply current	$\Delta I_{CC}$	4.5V to 5.5V	One input at $V_I=V_{CC}-2.1V$ ; Other inputs at $V_{CC}$ or GND; $I_O=0A$	-	-	135	$\mu A$

### 3.3.2、DC Characteristics 2

( $T_{amb}=-40^{\circ}C$  to  $+125^{\circ}C$ , voltages are referenced to GND (ground=0V), unless otherwise specified.)

Parameter	Symbol	$V_{CC}$	Conditions	Min.	Typ.	Max.	Unit
<b>SN74HC194</b>							
HIGH-level input voltage	$V_{IH}$	2.0V	-	1.5	-	-	V
		4.5V	-	3.15	-	-	V
		6.0V	-	4.2	-	-	V
LOW-level input voltage	$V_{IL}$	2.0V	-	-	-	0.5	V
		4.5V	-	-	-	1.35	V
		6.0V	-	-	-	1.8	V
HIGH-level output voltage	$V_{OH}$	2.0V	$I_O=-20\mu A$	1.9	-	-	V
		4.5V	$I_O=-20\mu A$	4.4	-	-	V
		6.0V	$I_O=-20\mu A$	5.9	-	-	V
		4.5V	$I_O=-4.0mA$	3.7	-	-	V
		6.0V	$I_O=-5.2mA$	5.2	-	-	V
LOW-level output voltage	$V_{OL}$	2.0V	$I_O=20\mu A$	-	-	0.1	V
		4.5V	$I_O=20\mu A$	-	-	0.1	V
		6.0V	$I_O=20\mu A$	-	-	0.1	V
		4.5V	$I_O=4.0mA$	-	-	0.4	V
		6.0V	$I_O=5.2mA$	-	-	0.4	V
input leakage current	$I_I$	6.0V	$V_I=V_{CC}$ or GND	-	-	$\pm 1$	$\mu A$
supply current	$I_{CC}$	6.0V	$V_I=V_{CC}$ or GND; $I_O=0A$	-	-	160	$\mu A$
<b>SN74HCT194</b>							



HIGH-level input voltage	$V_{IH}$	4.5V to 5.5V	-	2.0	-	-	V
LOW-level input voltage	$V_{IL}$	4.5V to 5.5V	-	-	-	0.8	V
HIGH-level output voltage	$V_{OH}$	4.5V	$I_O=-20\mu A$	4.4	-	-	V
			$I_O=-4.0mA$	3.7	-	-	V
LOW-level output voltage	$V_{OL}$	4.5V	$I_O=20\mu A$	-	-	0.1	V
			$I_O=4.0mA$	-	-	0.4	V
input leakage current	$I_I$	5.5V	$V_I=V_{CC}$ or GND	-	-	$\pm 1$	$\mu A$
supply current	$I_{CC}$	6.0V	$V_I=V_{CC}$ or GND; $I_O=0A$	-	-	160	$\mu A$
additional supply current	$\Delta I_{CC}$	4.5V to 5.5V	One input at $V_I=V_{CC}-2.1V$ ; Other inputs at $V_{CC}$ or GND; $I_O=0A$	-	-	147	$\mu A$

### 3.3.3、AC Characteristics 1

( $T_{amb}=-40^{\circ}C$  to  $+85^{\circ}C$ , voltages are referenced to GND (ground=0V), unless otherwise specified.)

Parameter	Symbol	$V_{CC}$	Conditions	Min.	Typ.	Max.	Unit	
<b>SN74HC194</b>								
CP to Qn propagation delay	$t_{PLH}, t_{PHL}$	2.0V	$C_L=50pF$	see Figure 4	-	47	155	ns
		4.5V	$C_L=50pF$		-	17	36	ns
		6.0V	$C_L=50pF$		-	14	31	ns
$\overline{MR}$ to Qn propagation delay	$t_{PHL}$	2.0V	$C_L=50pF$	see Figure 5	-	39	175	ns
		4.5V	$C_L=50pF$		-	14	35	ns
		6.0V	$C_L=50pF$		-	11	30	ns
transition time	$t_{THL}, t_{TLH}$	2.0V	$C_L=50pF$	see Figure 5	100	17	-	ns
		4.5V	$C_L=50pF$		20	6	-	ns
		6.0V	$C_L=50pF$		17	5	-	ns
clock pulse width	$t_w$	2.0V	$C_L=50pF$	see Figure 4	100	17	-	ns
		4.5V	$C_L=50pF$		20	6	-	ns
		6.0V	$C_L=50pF$		17	5	-	ns
master reset pulse	$t_w$	2.0V	$C_L=50pF$	see Figure 5	100	17	-	ns
		4.5V	$C_L=50pF$		20	6	-	ns
		6.0V	$C_L=50pF$		17	5	-	ns
$\overline{MR}$ to CP removal time	trem	2.0V	$C_L=50pF$	see Figure 5	60	17	-	ns
		4.5V	$C_L=50pF$		12	6	-	ns
		6.0V	$C_L=50pF$		10	5	-	ns
Dn to CP set-up time	$t_{su}$	2.0V	$C_L=50pF$	see Figure 6	90	17	-	ns
		4.5V	$C_L=50pF$		18	6	-	ns
		6.0V	$C_L=50pF$		15	5	-	ns
S0, S1 to CP set-up time	$t_{su}$	2.0V	$C_L=50pF$	see Figure 7	100	22	-	ns
		4.5V	$C_L=50pF$		20	8	-	ns
		6.0V	$C_L=50pF$		17	6	-	ns
DSR, DSL to CP set-up time	$t_{su}$	2.0V	$C_L=50pF$	see Figure 6	90	19	-	ns
		4.5V	$C_L=50pF$		18	7	-	ns
		6.0V	$C_L=50pF$		15	6	-	ns



Dn to CP hold time		2.0V	$C_L=50\text{pF}$	see Figure 6	0	-14	-	ns
		4.5V	$C_L=50\text{pF}$		0	-5	-	ns
		6.0V	$C_L=50\text{pF}$		0	-4	-	ns
S0, S1 to CP hold time	th	2.0V	$C_L=50\text{pF}$	see Figure 7	0	-11	-	ns
		4.5V	$C_L=50\text{pF}$		0	-4	-	ns
		6.0V	$C_L=50\text{pF}$		0	-3	-	ns
DSR, DSL to CP hold time		2.0V	$C_L=50\text{pF}$	see Figure 6	0	-17	-	ns
		4.5V	$C_L=50\text{pF}$		0	-6	-	ns
		6.0V	$C_L=50\text{pF}$		0	-5	-	ns
maximum clock pulse frequency	fmax	2.0V	$C_L=50\text{pF}$	see Figure 4	4.8	31	-	MHz
		4.5V	$C_L=50\text{pF}$		24	93	-	MHz
		6.0V	$C_L=50\text{pF}$		28	111	-	MHz
<b>SN74HCT194</b>								
CP to Qn propagation delay	$t_{PLH}, t_{PHL}$	4.5V	$C_L=50\text{pF}$	see Figure 4	-	18	40	ns
$\overline{\text{MR}}$ to Qn propagation delay	$t_{PHL}$	4.5V	$C_L=50\text{pF}$	see Figure 5	-	18	40	ns
transition time	$t_{THL}, t_{TLH}$	4.5V	$C_L=50\text{pF}$	see Figure 5	-	7	19	ns
clock pulse width	$t_w$	4.5V	$C_L=50\text{pF}$	see Figure 4	20	7	-	ns
master reset pulse	$t_w$	4.5V	$C_L=50\text{pF}$	see Figure 5	20	7	-	ns
$\overline{\text{MR}}$ to CP removal time	trem	4.5V	$C_L=50\text{pF}$	see Figure 5	15	6	-	ns
Dn to CP set-up time	tsu	4.5V	$C_L=50\text{pF}$	see Figure 6	18	7	-	ns
S0, S1 to CP set-up time		4.5V	$C_L=50\text{pF}$	see Figure 7	25	10	-	ns
DSR, DSL to CP set-up time		4.5V	$C_L=50\text{pF}$	see Figure 6	18	-	-	ns
Dn to CP hold time	th	4.5V	$C_L=50\text{pF}$	see Figure 6	0	-7	-	ns
S0, S1 to CP hold time		4.5V	$C_L=50\text{pF}$	see Figure 7	0	-5	-	ns
DSR, DSL to CP hold time		4.5V	$C_L=50\text{pF}$	see Figure 6	0	-7	-	ns
maximum clock pulse frequency	fmax	4.5V	$C_L=50\text{pF}$	see Figure 4	24	70	-	MHz



### 3.3.4、AC Characteristics 2

( $T_{amb} = -40^{\circ}\text{C}$  to  $+125^{\circ}\text{C}$ , voltages are referenced to GND (ground=0V), unless otherwise specified.)

Parameter	Symbol	V <sub>CC</sub>	Conditions	Min.	Typ.	Max.	Unit	
<b>SN74HC194</b>								
CP to Qn propagation delay	t <sub>PLH</sub> , t <sub>PHL</sub>	2.0V	C <sub>L</sub> =50pF	see Figure 4	-	-	220	ns
		4.5V	C <sub>L</sub> =50pF		-	-	44	ns
		6.0V	C <sub>L</sub> =50pF		-	-	38	ns
$\overline{\text{MR}}$ to Qn propagation delay	t <sub>PHL</sub>	2.0V	C <sub>L</sub> =50pF	see Figure 5	-	-	210	ns
		4.5V	C <sub>L</sub> =50pF		-	-	42	ns
		6.0V	C <sub>L</sub> =50pF		-	-	36	ns
transition time	t <sub>THL</sub> , t <sub>TLH</sub>	2.0V	C <sub>L</sub> =50pF	see Figure 5	-	-	110	ns
		4.5V	C <sub>L</sub> =50pF		-	-	22	ns
		6.0V	C <sub>L</sub> =50pF		-	-	19	ns
clock pulse width	t <sub>w</sub>	2.0V	C <sub>L</sub> =50pF	see Figure 4	120	-	-	ns
		4.5V	C <sub>L</sub> =50pF		24	-	-	ns
		6.0V	C <sub>L</sub> =50pF		20	-	-	ns
master reset pulse	t <sub>w</sub>	2.0V	C <sub>L</sub> =50pF	see Figure 5	120	-	-	ns
		4.5V	C <sub>L</sub> =50pF		24	-	-	ns
		6.0V	C <sub>L</sub> =50pF		20	-	-	ns
$\overline{\text{MR}}$ to CP removal time	t <sub>rem</sub>	2.0V	C <sub>L</sub> =50pF	see Figure 5	90	-	-	ns
		4.5V	C <sub>L</sub> =50pF		18	-	-	ns
		6.0V	C <sub>L</sub> =50pF		15	-	-	ns
Dn to CP set-up time		2.0V	C <sub>L</sub> =50pF	see Figure 6	105	-	-	ns
		4.5V	C <sub>L</sub> =50pF		21	-	-	ns
		6.0V	C <sub>L</sub> =50pF		18	-	-	ns
S0, S1 to CP set-up time	t <sub>su</sub>	2.0V	C <sub>L</sub> =50pF	see Figure 7	120	-	-	ns
		4.5V	C <sub>L</sub> =50pF		24	-	-	ns
		6.0V	C <sub>L</sub> =50pF		20	-	-	ns
DSR, DSL to CP set-up time		2.0V	C <sub>L</sub> =50pF	see Figure 6	105	-	-	ns
		4.5V	C <sub>L</sub> =50pF		21	-	-	ns
		6.0V	C <sub>L</sub> =50pF		18	-	-	ns
Dn to CP hold time		2.0V	C <sub>L</sub> =50pF	see Figure 6	0	-	-	ns
		4.5V	C <sub>L</sub> =50pF		0	-	-	ns
		6.0V	C <sub>L</sub> =50pF		0	-	-	ns
S0, S1 to CP hold time	t <sub>h</sub>	2.0V	C <sub>L</sub> =50pF	see Figure 7	0	-	-	ns
		4.5V	C <sub>L</sub> =50pF		0	-	-	ns
		6.0V	C <sub>L</sub> =50pF		0	-	-	ns
DSR, DSL to CP hold time		2.0V	C <sub>L</sub> =50pF	see Figure 6	0	-	-	ns
		4.5V	C <sub>L</sub> =50pF		0	-	-	ns
		6.0V	C <sub>L</sub> =50pF		0	-	-	ns
maximum clock pulse frequency	f <sub>max</sub>	2.0V	C <sub>L</sub> =50pF	see Figure 4	4.0	-	-	MHz
		4.5V	C <sub>L</sub> =50pF		20	-	-	MHz
		6.0V	C <sub>L</sub> =50pF		24	-	-	MHz
<b>SN74HCT194</b>								
CP to Qn	t <sub>PLH</sub> , t <sub>PHL</sub>	4.5V	C <sub>L</sub> =50pF	see Figure 4	-	-	48	ns



propagation delay								
$\overline{\text{MR}}$ to Qn propagation delay	$t_{\text{PHL}}$	4.5V	$C_L=50\text{pF}$	see Figure 5	-	-	48	ns
transition time	$t_{\text{THL}}, t_{\text{TLH}}$	4.5V	$C_L=50\text{pF}$	see Figure 5	-	-	22	ns
clock pulse width	$t_w$	4.5V	$C_L=50\text{pF}$	see Figure 4	24	-	-	ns
master reset pulse	$t_w$	4.5V	$C_L=50\text{pF}$	see Figure 5	24	-	-	ns
$\overline{\text{MR}}$ to CP removal time	trem	4.5V	$C_L=50\text{pF}$	see Figure 5	18	-	-	ns
Dn to CP set-up time	tsu	4.5V	$C_L=50\text{pF}$	see Figure 6	21	-	-	ns
S0, S1 to CP set-up time		4.5V	$C_L=50\text{pF}$	see Figure 7	30	-	-	ns
DSR, DSL to CP set-up time		4.5V	$C_L=50\text{pF}$	see Figure 6	21	-	-	ns
Dn to CP hold time	th	4.5V	$C_L=50\text{pF}$	see Figure 6	0	-	-	ns
S0, S1 to CP hold time		4.5V	$C_L=50\text{pF}$	see Figure 7	0	-	-	ns
DSR, DSL to CP hold time		4.5V	$C_L=50\text{pF}$	see Figure 6	0	-	-	ns
maximum clock pulse frequency	fmax	4.5V	$C_L=50\text{pF}$	see Figure 4	20	-	-	MHz





## 4、Testing Circuit

### 4.1、AC Testing Circuit

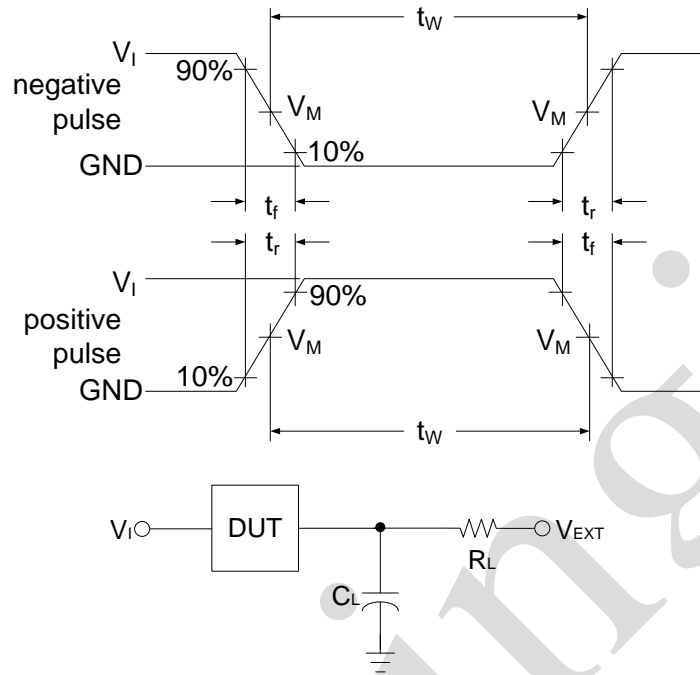

Figure 3. Test circuit for measuring switching times

$C_L$  includes probe and jig capacitance.

### 4.2、Test Data

Type	Input		Load		$V_{EXT}$		
	$V_I$	$t_r = t_f$	$C_L$	$R_L$	$t_{PLH}/t_{PHL}$	$t_{PLZ}/t_{PZL}$	$t_{PHZ}/t_{PZH}$
SN74HC194	$V_{CC}$	6.0ns	50pF	1K $\Omega$	Open	$V_{CC}$	GND
SN74HCT194	3.0V	6.0ns	50pF	1K $\Omega$	Open	$V_{CC}$	GND



### 4.3. AC Testing Waveforms

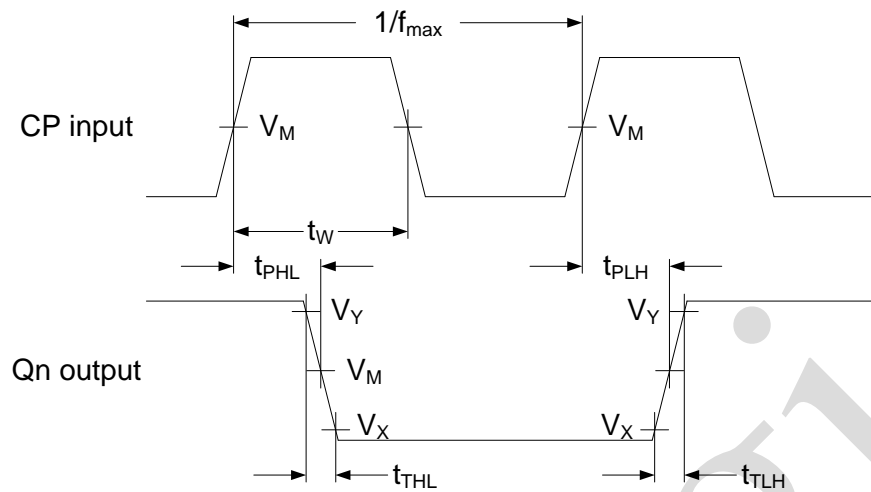

Figure 4. Waveforms showing the clock (CP) to output (Qn) propagation delays, the clock pulse width, the output transition times and the maximum clock frequency

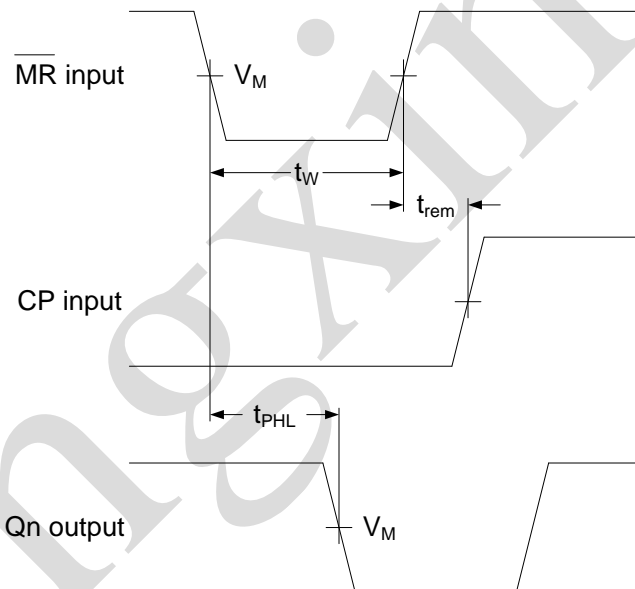

Figure 5. Waveforms showing the master reset ( $\overline{MR}$ ) pulse width, the master reset to output (Qn) propagation delays and the master reset to clock (CP) removal time

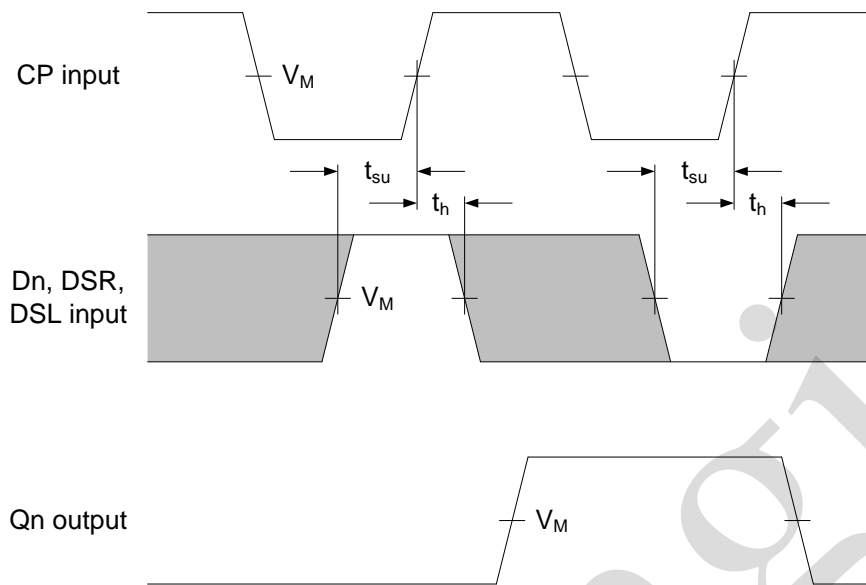

Figure 6. Waveforms showing the set-up and hold times from the data inputs (Dn, DSR and DSL) to the clock (CP).

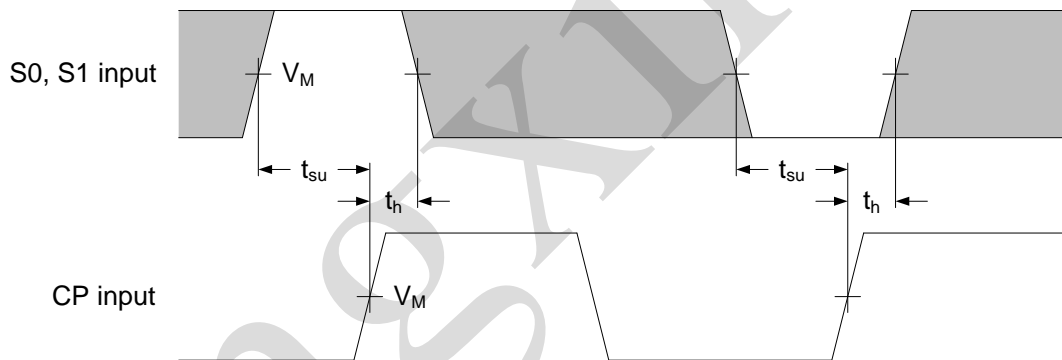

Figure 7. Waveforms showing the set-up and hold times from the mode control inputs (Sn) to the clock input (CP).

#### 4.4. Measurement Points

Type	Input		Output	
	$V_M$	$V_M$	$V_X$	$V_Y$
SN74HC194	$0.5 \times V_{CC}$	$0.5 \times V_{CC}$	$0.1 \times V_{CC}$	$0.9 \times V_{CC}$
SN74HCT194	1.3V	1.3V	$0.1 \times V_{CC}$	$0.9 \times V_{CC}$



## 5、Package Information

### 5.1、DIP16

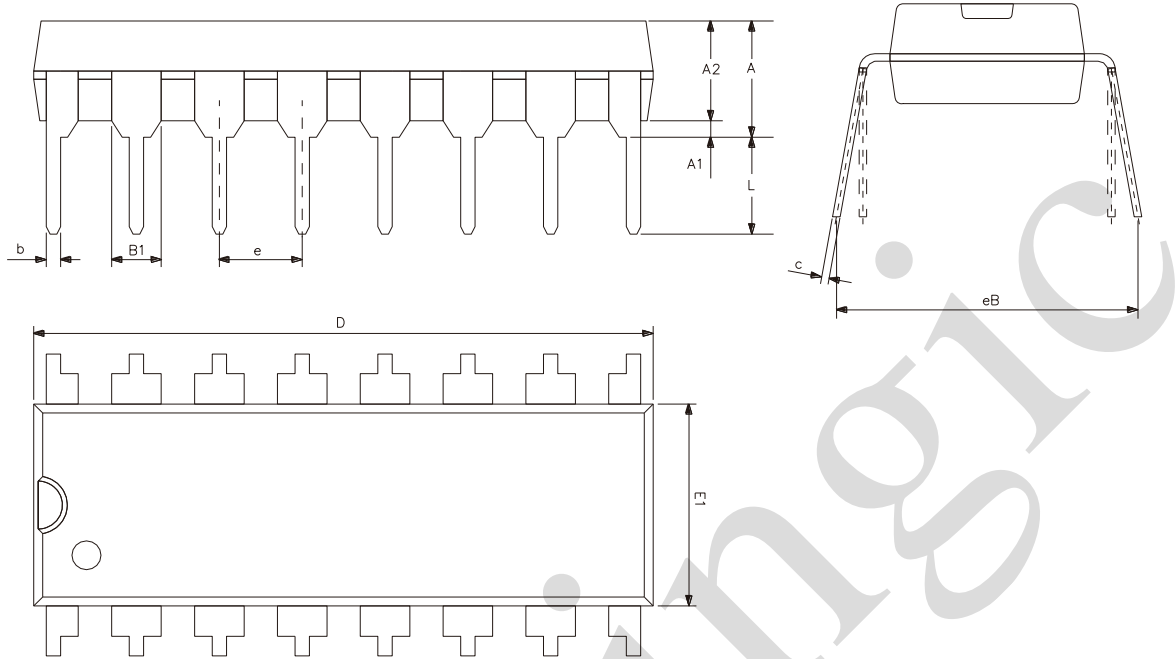

Symbol	Dimensions (mm)	
	Min.	Max.
A2	3.20	3.60
A1	0.51	-
A	3.60	5.33
L	3.00	3.60
b	0.36	0.56
B1	1.52	
D	18.80	19.94
E1	6.20	6.60
e	2.54	
c	0.20	0.36
eB	7.62	9.30



## 5.2、SOP16

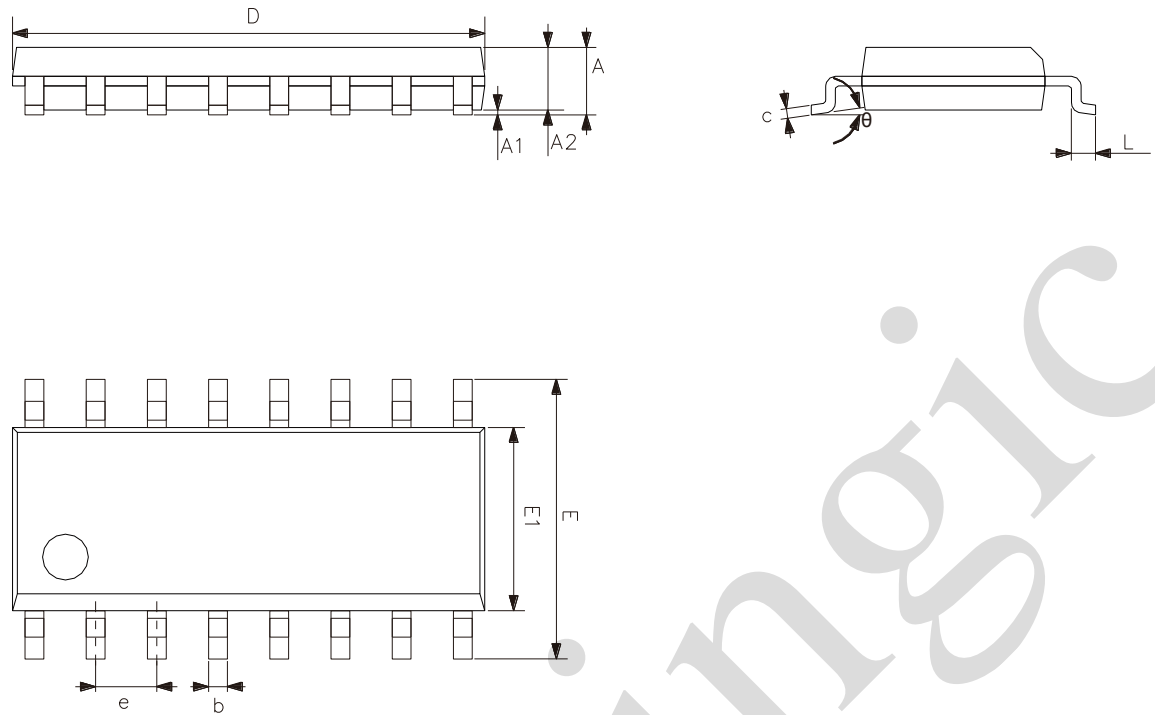

Symbol	Dimensions (mm)	
	Min.	Max.
A	1.35	1.80
A1	0.10	0.25
A2	1.25	1.55
b	0.33	0.51
c	0.19	0.25
D	9.50	10.10
E	5.80	6.30
E1	3.70	4.10
e	1.27	
L	0.35	0.89
$\theta$	0°	8°



### 5.3、TSSOP16

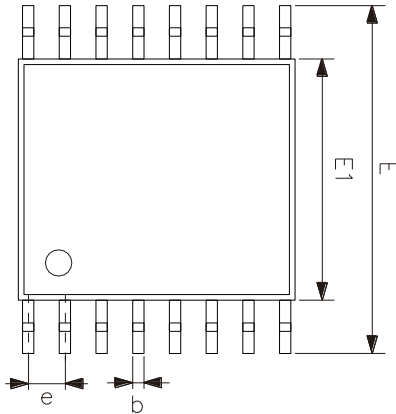
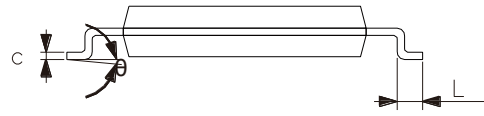
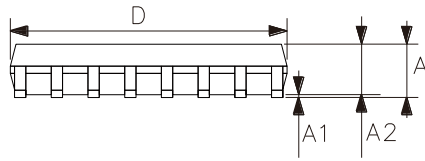

Symbol	Dimensions (mm)	
	Min.	Max.
A	-	1.20
A1	0.05	0.15
A2	0.80	1.05
b	0.19	0.30
c	0.09	0.20
D	4.90	5.10
E1	4.30	4.50
E	6.20	6.60
e	0.65	
L	0.45	0.75
$\theta$	0°	8°



## 6、 Statements And Notes

### 6.1、 The name and content of Hazardous substances or Elements in the product

Part name	Hazardous substances or Elements									
	Lead and lead compounds	Mercury and mercury compounds	Cadmium and cadmium compounds	Hexavalent chromium compounds	Polybrominated biphenyls	Polybrominated biphenyl ethers	Dibutyl phthalate	Butylbenzyl phthalate	Di-2-ethylhexyl phthalate	Diisobutyl phthalate
Lead frame	○	○	○	○	○	○	○	○	○	○
Plastic resin	○	○	○	○	○	○	○	○	○	○
Chip	○	○	○	○	○	○	○	○	○	○
The lead	○	○	○	○	○	○	○	○	○	○
Plastic sheet installed	○	○	○	○	○	○	○	○	○	○
explanation	○: Indicates that the content of hazardous substances or elements in the detection limit of the following the SJ/T11363-2006 standard. ×: Indicates that the content of hazardous substances or elements exceeding the SJ/T11363-2006 Standard limit requirements.									

### 6.2、 Notes

We recommend you to read this chapter carefully before using this product.

The information in this chapter is provided for reference only and Lingxing disclaims any express or implied warranties, including but not limited to applicability, special application or non-infringement of third party rights.

This product is not suitable for critical equipment such as life-saving, life-sustaining or safety equipment. It is also not suitable for applications that may result in personal injury, death, or serious property or environmental damage due to product malfunction or failure. Lingxing will not be liable for any damages incurred by the customers at their own risk for such applications.

The customer is responsible for conducting all necessary tests Lingxing's application to avoid failure in the application or the application of the customer's third party users. Lingxing does not accept any liability. The Company reserves the right to change or improve the information published in this chapter at any time. The information in this chapter are subject to change without notice. We recommend the customer to consult our sales staff before purchasing.

Please obtain related materials form Lingxing's regular channels and we are not responsible for its content if it is provided by sources other than our company.

In case of any conflict between the Chinese and English version, the version is subject to the Chinese one.

## X-ON Electronics

Largest Supplier of Electrical and Electronic Components

*Click to view similar products for [Counter Shift Registers](#) category:*

*Click to view products by [lingxingic](#) manufacturer:*

Other Similar products are found below :

[CD4031BE](#) [CD4034BE](#) [NLV74HC165ADTR2G](#) [5962-9172201M2A](#) [MC100EP142MNG](#) [MC100EP016AMNG](#) [MC74LV594ADR2G](#)  
[NLV14094BDTR2G](#) [NLV74HC589ADR2G](#) [AiP74HC595TA16.TR](#) [SN74LS295BN](#) [AIP74HC164TA14.TR](#) [TM74HC164](#) [74HC164D](#)  
[AiP74HC165SA16.TR](#) [74HC573D](#) [AiP74HC165TA16.TR](#) [XL74HC597-TS](#) [74HC164MT/TR](#) [XL74HC595TS](#) [74HC595DMT/TR](#)  
[CD4094DMT/TR](#) [74HC595D\(MS\)](#) [CD4094DM/TR](#) [74HC164D](#) [GN165D](#) [74HC595DM/TR](#) [AIP74HC595SA.TR](#) [XL4021B](#)  
[74HC164D\(MS\)](#) [74HC595MT/TR](#) [XL74HC165-TS](#) [74HC595D](#) [74HC595D](#) [74HC595D.](#) [74HCT595BQ](#) [RS595SXTSS16](#)  
[Aip74HC595SA16.TR](#) [SN74LS164DR-HXY](#) [74HC164DR](#) [RS595SXS16](#) [74HC165-HXY](#) [RS164XQ](#) [GN74HC595D](#) [74HC164DRG](#)  
[XD74HC165](#) [SN74LV165AQWBQBRQ1](#) [AiP74HC4094SA16.TR](#) [HX74HC595IDRG](#) [CD4094DN](#)