



SN74HC/HCT367 (LX) Hex Buffer/Line Driver; 3-state

Product Specification

Specification Revision History:

Version	Date	Description
2022-06-A1	2022-06	New
2023-04-B1	2023-04	Update the template



Contents

1、 General Description.....	3
2、 Block Diagram And Pin Description	5
2.1、 Block Diagram	5
2.2、 Pin Configurations.....	6
2.3、 Pin Description	6
2.4、 Function Table.....	6
3、 Electrical Parameter	7
3.1、 Absolute Maximum Ratings.....	7
3.2、 Recommended Operating Conditions	7
3.3、 Electrical Characteristics	8
3.3.1、 DC Characteristics 1	8
3.3.2、 DC Characteristics 2	9
3.3.3、 DC Characteristics 3	10
3.3.4、 AC Characteristics 1	11
3.3.5、 AC Characteristics 2	12
3.3.6、 AC Characteristics 3	13
4、 Testing Circuit	14
4.1、 AC Testing Circuit	14
4.2、 AC Testing Waveforms.....	14
4.3、 Measurement Points	15
4.4、 Test Data	15
5、 Package Information	16
5.1、 DIP16	16
5.2、 SOP16	17
5.3、 TSSOP16.....	18
6、 Statements And Notes	19
6.1、 The name and content of Hazardous substances or Elements in the product	19
6.2、 Notes	19



灵星芯微 集成电路

1、General Description

The SN74HC/HCT367 is a hex buffer/line driver with 3-state outputs controlled by the output enable inputs (\overline{nOE}). A HIGH on \overline{nOE} causes the outputs to assume a high impedance OFF-state. Inputs include clamp diodes. This enables the use of current limiting resistors to interface inputs to voltages in excess of V_{CC} .

Features:

- Input levels:
 - For SN74HC367: CMOS level
 - For SN74HCT367: TTL level
- 3-state outputs
- Specified from -40°C to $+125^{\circ}\text{C}$
- Packaging information: DIP16/SOP16/TSSOP16

Ordering Information:

Tube packing specifications:

Part number	Packaging form	Marking code	Tube quantity	Boxed tube quantity	Boxed quantity	Notes
SN74HC367N(LX)	DIP16	SN74HC367N	25 PCS/tube	40 tube/box	1000 PCS/box	Dimensions of plastic enclosure: 19.0mm×6.4mm Pin spacing: 2.54mm
SN74HCT367N(LX)	DIP16	SN74HCT367N	25 PCS/tube	40 tube/box	1000 PCS/box	Dimensions of plastic enclosure: 19.0mm×6.4mm Pin spacing: 2.54mm
SN74HC367DR(LX)	SOP16	SN74HC367	50 PCS/tube	200 tube/box	10000 PCS/box	Dimensions of plastic enclosure: 10.0mm×3.9mm Pin spacing: 1.27mm
SN74HCT367DR(LX)	SOP16	SN74HCT367	50 PCS/tube	200 tube/box	10000 PCS/box	Dimensions of plastic enclosure: 10.0mm×3.9mm Pin spacing: 1.27mm
SN74HC367PW(LX)	TSSOP16	HC367	96 PCS/tube	200 tube/box	19200 PCS/box	Dimensions of plastic enclosure: 5.0mm×4.4mm Pin spacing: 0.65mm
SN74HCT367PW(LX)	TSSOP16	HCT367	96 PCS/tube	200 tube/box	19200 PCS/box	Dimensions of plastic enclosure: 5.0mm×4.4mm Pin spacing: 0.65mm



灵星芯微 集成电路

Reel packing specifications:

Part number	Packaging form	Marking code	Reel quantity	Boxed reel quantity	Notes
SN74HC367DR(LX)	SOP16	SN74HC367	4000 PCS/reel	8000 PCS/box	Dimensions of plastic enclosure: 10.0mm×3.9mm Pin spacing:1.27mm
SN74HCT367DR(LX)	SOP16	SN74HCT367	4000 PCS/reel	8000 PCS/box	Dimensions of plastic enclosure: 10.0mm×3.9mm Pin spacing:1.27mm
SN74HC367PW(LX)	TSSOP16	74HC367	5000 PCS/reel	10000 PCS/box	Dimensions of plastic enclosure: 5.0mm×4.4mm Pin spacing:0.65mm
SN74HCT367PW(LX)	TSSOP16	74HCT367	5000 PCS/reel	10000 PCS/box	Dimensions of plastic enclosure: 5.0mm×4.4mm Pin spacing:0.65mm

Note: If the physical information is inconsistent with the ordering information, please refer to the actual product.



2、Block Diagram And Pin Description

2.1、Block Diagram

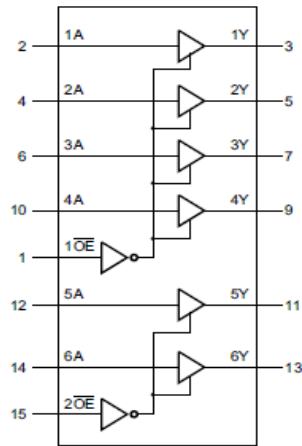

Figure 1. Logic symbol

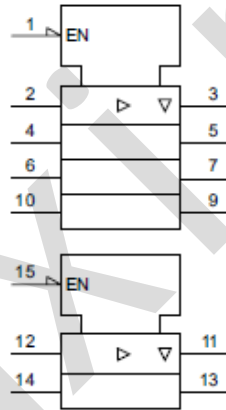

Figure 2. IEC logic symbol

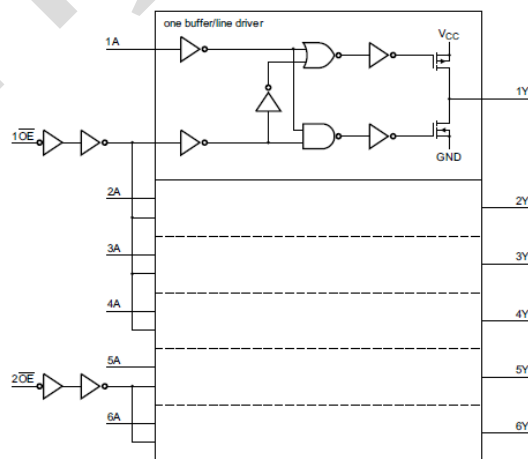
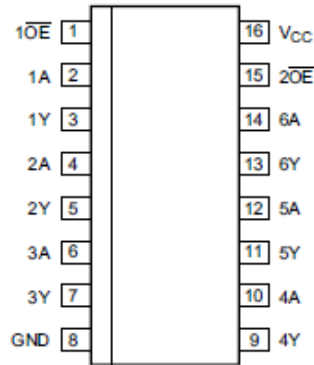

Figure 3. Logic diagram



2.2、Pin Configurations



2.3、Pin Description

Pin No.	Pin Name	Description
1	1OE	output enable input 1 (active LOW)
2	1A	data input 1
3	1Y	data output 1
4	2A	data input 2
5	2Y	data output 2
6	3A	data input 3
7	3Y	data output 3
8	GND	ground (0V)
9	4Y	data output 4
10	4A	data input 4
11	5Y	data output 5
12	5A	data input 5
13	6Y	data output 6
14	6A	data input 6
15	2OE	output enable input 2 (active LOW)
16	V _{CC}	supply voltage

2.4、Function Table

Input		Output
nOE	nA	nY
L	L	L
L	H	H
H	X	Z

Note: H=HIGH voltage level; L=LOW voltage level; X=don't care; Z=high-impedance OFF-state.



3、Electrical Parameter

3.1、Absolute Maximum Ratings

(Voltages are referenced to GND(ground=0V), unless otherwise specified.)

Parameter	Symbol	Conditions	Min.	Max.	Unit
supply voltage	V_{CC}	-	-0.5	+7.0	V
input clamping current	I_{IK}	$V_I < -0.5V$ or $V_I > V_{CC}+0.5V$	-	± 20	mA
output clamping current	I_{OK}	$V_O < -0.5V$ or $V_O > V_{CC}+0.5V$	-	± 20	mA
output current	I_O	$-0.5V < V_O < V_{CC}+0.5V$	-	± 35	mA
supply current	I_{CC}	-	-	70	mA
ground current	I_{GND}	-	-70	-	mA
storage temperature	T_{stg}	-	-65	+150	°C
total power dissipation	P_{tot}	-	-	500	mW
Soldering temperature	T_L	10s	DIP	245	°C
			SOP/TSSOP	260	

3.2、Recommended Operating Conditions

Parameter	Symbol	Conditions	Min.	Typ.	Max.	Unit
SN74HC367						
supply voltage	V_{CC}	-	2.0	5.0	6.0	V
input voltage	V_I	-	0	-	V_{CC}	V
output voltage	V_O	-	0	-	V_{CC}	V
input transition rise and fall rate	$\Delta t/\Delta V$	$V_{CC}=2.0V$	-	-	625	ns/V
		$V_{CC}=4.5V$	-	1.67	139	ns/V
		$V_{CC}=6.0V$	-	-	83	ns/V
ambient temperature	T_{amb}	-	-40	-	+125	°C
SN74HCT367						
supply voltage	V_{CC}	-	4.5	5.0	5.5	V
input voltage	V_I	-	0	-	V_{CC}	V
output voltage	V_O	-	0	-	V_{CC}	V
input transition rise and fall rate	$\Delta t/\Delta V$	$V_{CC}=4.5V$	-	1.67	139	ns/V
ambient temperature	T_{amb}	-	-40	-	+125	°C



3.3、Electrical Characteristics

3.3.1、DC Characteristics 1

($T_{amb}=25^{\circ}\text{C}$, voltages are referenced to GND (ground=0V), unless otherwise specified.)

Parameter	Symbol	Conditions	Min.	Typ.	Max.	Unit	
SN74HC367							
HIGH-level input voltage	V_{IH}	$V_{CC}=2.0\text{V}$	1.5	1.2	-	V	
		$V_{CC}=4.5\text{V}$	3.15	2.4	-	V	
		$V_{CC}=6.0\text{V}$	4.2	3.2	-	V	
LOW-level input voltage	V_{IL}	$V_{CC}=2.0\text{V}$	-	0.8	0.5	V	
		$V_{CC}=4.5\text{V}$	-	2.1	1.35	V	
		$V_{CC}=6.0\text{V}$	-	2.8	1.8	V	
HIGH-level output voltage	V_{OH}	$V_I = V_{IH} \text{ or } V_{IL}$	$I_O=-20\mu\text{A}; V_{CC}=2.0\text{V}$	1.9	2.0	-	V
			$I_O=-20\mu\text{A}; V_{CC}=4.5\text{V}$	4.4	4.5	-	V
			$I_O=-20\mu\text{A}; V_{CC}=6.0\text{V}$	5.9	6.0	-	V
			$I_O=-6.0\text{mA}; V_{CC}=4.5\text{V}$	3.98	4.32	-	V
			$I_O=-7.8\text{mA}; V_{CC}=6.0\text{V}$	5.48	5.81	-	V
LOW-level output voltage	V_{OL}	$V_I = V_{IH} \text{ or } V_{IL}$	$I_O=20\mu\text{A}; V_{CC}=2.0\text{V}$	-	0	0.1	V
			$I_O=20\mu\text{A}; V_{CC}=4.5\text{V}$	-	0	0.1	V
			$I_O=20\mu\text{A}; V_{CC}=6.0\text{V}$	-	0	0.1	V
			$I_O=6.0\text{mA}; V_{CC}=4.5\text{V}$	-	0.15	0.26	V
			$I_O=7.8\text{mA}; V_{CC}=6.0\text{V}$	-	0.16	0.26	V
input leakage current	I_I	$V_I=V_{CC} \text{ or } \text{GND}; V_{CC}=6.0\text{V}$	-	-	± 1.0	μA	
OFF-state output current	I_{OZ}	$V_I=V_{IH} \text{ or } V_{IL}; V_{CC}=6.0\text{V}; V_O=V_{CC} \text{ or } \text{GND}$	-	-	± 1.0	μA	
supply current	I_{CC}	$V_I=V_{CC} \text{ or } \text{GND}; I_O=0\text{A}; V_{CC}=6.0\text{V}$	-	-	8.0	μA	
input capacitance	C_I	-	-	3.5	-	pF	
SN74HCT367							
HIGH-level input voltage	V_{IH}	$V_{CC}=4.5\text{V to } 5.5\text{V}$	2.0	1.6	-	V	
LOW-level input voltage	V_{IL}	$V_{CC}=4.5\text{V to } 5.5\text{V}$	-	1.2	0.8	V	
HIGH-level output voltage	V_{OH}	$V_I = V_{IH} \text{ or } V_{IL}; V_{CC}=4.5\text{V}$	$I_O=-20\mu\text{A}$	4.4	4.5	-	V
			$I_O=-6.0\text{mA}$	3.98	4.32	-	V
LOW-level output voltage	V_{OL}	$V_I = V_{IH} \text{ or } V_{IL}; V_{CC}=4.5\text{V}$	$I_O=20\mu\text{A}$	-	0	0.1	V
			$I_O=6.0\text{mA}$	-	0.16	0.26	V
input leakage current	I_I	$V_I=V_{CC} \text{ or } \text{GND}; V_{CC}=5.5\text{V}$	-	-	± 1.0	μA	
OFF-state output current	I_{OZ}	$V_I=V_{IH} \text{ or } V_{IL}; V_{CC}=5.5\text{V}; V_O=V_{CC} \text{ or } \text{GND}$	-	-	± 1.0	μA	
supply current	I_{CC}	$V_I=V_{CC} \text{ or } \text{GND}; I_O=0\text{A}; V_{CC}=5.5\text{V}$	-	-	8.0	μA	
additional supply current	ΔI_{CC}	per input pin; $V_I=V_{CC}-2.1\text{V};$ other inputs at V_{CC} or GND; $V_{CC}=4.5\text{V}$ to $5.5\text{V}; I_O=0\text{A}$	1OE, nA inputs	-	-	360	μA
			2OE input	-	-	324	μA
input	C_I	-	-	3.5	-	pF	



capacitance						
-------------	--	--	--	--	--	--

3.3.2、DC Characteristics 2

($T_{amb}=-40^{\circ}\text{C}$ to $+85^{\circ}\text{C}$, voltages are referenced to GND (ground=0V), unless otherwise specified.)

Parameter	Symbol	Conditions	Min.	Typ.	Max.	Unit	
SN74HC367							
HIGH-level input voltage	V_{IH}	$V_{CC}=2.0\text{V}$	1.5	-	-	V	
		$V_{CC}=4.5\text{V}$	3.15	-	-	V	
		$V_{CC}=6.0\text{V}$	4.2	-	-	V	
LOW-level input voltage	V_{IL}	$V_{CC}=2.0\text{V}$	-	-	0.5	V	
		$V_{CC}=4.5\text{V}$	-	-	1.35	V	
		$V_{CC}=6.0\text{V}$	-	-	1.8	V	
HIGH-level output voltage	V_{OH}	$V_I = V_{IH} \text{ or } V_{IL}$	$I_O=-20\mu\text{A}; V_{CC}=2.0\text{V}$	1.9	-	-	V
			$I_O=-20\mu\text{A}; V_{CC}=4.5\text{V}$	4.4	-	-	V
			$I_O=-20\mu\text{A}; V_{CC}=6.0\text{V}$	5.9	-	-	V
			$I_O=-6.0\text{mA}; V_{CC}=4.5\text{V}$	3.84	-	-	V
			$I_O=-7.8\text{mA}; V_{CC}=6.0\text{V}$	5.34	-	-	V
LOW-level output voltage	V_{OL}	$V_I = V_{IH} \text{ or } V_{IL}$	$I_O=20\mu\text{A}; V_{CC}=2.0\text{V}$	-	-	0.1	V
			$I_O=20\mu\text{A}; V_{CC}=4.5\text{V}$	-	-	0.1	V
			$I_O=20\mu\text{A}; V_{CC}=6.0\text{V}$	-	-	0.1	V
			$I_O=6.0\text{mA}; V_{CC}=4.5\text{V}$	-	-	0.33	V
			$I_O=7.8\text{mA}; V_{CC}=6.0\text{V}$	-	-	0.33	V
input leakage current	I_I	$V_I=V_{CC} \text{ or } \text{GND}; V_{CC}=6.0\text{V}$	-	-	± 1.0	μA	
OFF-state output current	I_{OZ}	$V_I=V_{IH} \text{ or } V_{IL}; V_{CC}=6.0\text{V}; V_O=V_{CC} \text{ or } \text{GND}$	-	-	± 5.0	μA	
supply current	I_{CC}	$V_I=V_{CC} \text{ or } \text{GND}; I_O=0\text{A}; V_{CC}=6.0\text{V}$	-	-	80	μA	
SN74HCT367							
HIGH-level input voltage	V_{IH}	$V_{CC}=4.5\text{V to } 5.5\text{V}$	2.0	-	-	V	
LOW-level input voltage	V_{IL}	$V_{CC}=4.5\text{V to } 5.5\text{V}$	-	-	0.8	V	
HIGH-level output voltage	V_{OH}	$V_I = V_{IH} \text{ or } V_{IL}; V_{CC}=4.5\text{V}$	$I_O=-20\mu\text{A}$	4.4	-	-	V
			$I_O=-6.0\text{mA}$	3.84	-	-	V
LOW-level output voltage	V_{OL}	$V_I = V_{IH} \text{ or } V_{IL}; V_{CC}=4.5\text{V}$	$I_O=20\mu\text{A}$	-	-	0.1	V
			$I_O=6.0\text{mA}$	-	-	0.33	V
input leakage current	I_I	$V_I=V_{CC} \text{ or } \text{GND}; V_{CC}=5.5\text{V}$	-	-	± 1.0	μA	
OFF-state output current	I_{OZ}	$V_I=V_{IH} \text{ or } V_{IL}; V_{CC}=5.5\text{V}; V_O=V_{CC} \text{ or } \text{GND}$	-	-	± 5.0	μA	
supply current	I_{CC}	$V_I=V_{CC} \text{ or } \text{GND}; I_O=0\text{A}; V_{CC}=5.5\text{V}$	-	-	80	μA	
additional supply current	ΔI_{CC}	per input pin; $V_I=V_{CC}-2.1\text{V};$ other inputs at V_{CC} or GND; $V_{CC}=4.5\text{V}$ to $5.5\text{V}; I_O=0\text{A}$	10E, nA inputs	-	-	450	μA
			20E input	-	-	405	μA



3.3.3、DC Characteristics 3

($T_{amb}=-40^{\circ}\text{C}$ to $+125^{\circ}\text{C}$, voltages are referenced to GND (ground=0V), unless otherwise specified.)

Parameter	Symbol	Conditions	Min.	Typ.	Max.	Unit	
SN74HC367							
HIGH-level input voltage	V_{IH}	$V_{CC}=2.0\text{V}$	1.5	-	-	V	
		$V_{CC}=4.5\text{V}$	3.15	-	-	V	
		$V_{CC}=6.0\text{V}$	4.2	-	-	V	
LOW-level input voltage	V_{IL}	$V_{CC}=2.0\text{V}$	-	-	0.5	V	
		$V_{CC}=4.5\text{V}$	-	-	1.35	V	
		$V_{CC}=6.0\text{V}$	-	-	1.8	V	
HIGH-level output voltage	V_{OH}	$V_I = V_{IH} \text{ or } V_{IL}$	$I_O=-20\mu\text{A}; V_{CC}=2.0\text{V}$	1.9	-	-	V
			$I_O=-20\mu\text{A}; V_{CC}=4.5\text{V}$	4.4	-	-	V
			$I_O=-20\mu\text{A}; V_{CC}=6.0\text{V}$	5.9	-	-	V
			$I_O=-6.0\text{mA}; V_{CC}=4.5\text{V}$	3.7	-	-	V
			$I_O=-7.8\text{mA}; V_{CC}=6.0\text{V}$	5.2	-	-	V
LOW-level output voltage	V_{OL}	$V_I = V_{IH} \text{ or } V_{IL}$	$I_O=20\mu\text{A}; V_{CC}=2.0\text{V}$	-	-	0.1	V
			$I_O=20\mu\text{A}; V_{CC}=4.5\text{V}$	-	-	0.1	V
			$I_O=20\mu\text{A}; V_{CC}=6.0\text{V}$	-	-	0.1	V
			$I_O=6.0\text{mA}; V_{CC}=4.5\text{V}$	-	-	0.4	V
			$I_O=7.8\text{mA}; V_{CC}=6.0\text{V}$	-	-	0.4	V
input leakage current	I_I	$V_I=V_{CC} \text{ or } \text{GND}; V_{CC}=6.0\text{V}$	-	-	± 1.0	μA	
OFF-state output current	I_{OZ}	$V_I=V_{IH} \text{ or } V_{IL}; V_{CC}=6.0\text{V}; V_O=V_{CC} \text{ or } \text{GND}$	-	-	± 10	μA	
supply current	I_{CC}	$V_I=V_{CC} \text{ or } \text{GND}; I_O=0\text{A}; V_{CC}=6.0\text{V}$	-	-	160	μA	
SN74HCT367							
HIGH-level input voltage	V_{IH}	$V_{CC}=4.5\text{V to } 5.5\text{V}$	2.0	-	-	V	
LOW-level input voltage	V_{IL}	$V_{CC}=4.5\text{V to } 5.5\text{V}$	-	-	0.8	V	
HIGH-level output voltage	V_{OH}	$V_I = V_{IH} \text{ or } V_{IL}; V_{CC}=4.5\text{V}$	$I_O=-20\mu\text{A}$	4.4	-	-	V
			$I_O=-6.0\text{mA}$	3.7	-	-	V
LOW-level output voltage	V_{OL}	$V_I = V_{IH} \text{ or } V_{IL}; V_{CC}=4.5\text{V}$	$I_O=20\mu\text{A}$	-	-	0.1	V
			$I_O=6.0\text{mA}$	-	-	0.4	V
input leakage current	I_I	$V_I=V_{CC} \text{ or } \text{GND}; V_{CC}=5.5\text{V}$	-	-	± 1.0	μA	
OFF-state output current	I_{OZ}	$V_I=V_{IH} \text{ or } V_{IL}; V_{CC}=5.5\text{V}; V_O=V_{CC} \text{ or } \text{GND}$	-	-	± 10	μA	
supply current	I_{CC}	$V_I=V_{CC} \text{ or } \text{GND}; I_O=0\text{A}; V_{CC}=5.5\text{V}$	-	-	160	μA	
additional supply current	ΔI_{CC}	per input pin; $V_I=V_{CC}-2.1\text{V};$ other inputs at V_{CC} or GND; $V_{CC}=4.5\text{V}$ to $5.5\text{V}; I_O=0\text{A}$	1OE, nA inputs	-	-	490	μA
			2OE input	-	-	441	μA



3.3.4、AC Characteristics 1

($T_{amb}=25^{\circ}C$, $GND=0V$, $C_L=50pF$, unless otherwise specified.)

Parameter	Symbol	Conditions	Min.	Typ.	Max.	Unit	
SN74HC367							
nA to nY propagation delay	t_{pd}	see Figure 5	$V_{CC}=2.0V$	-	28	95	ns
			$V_{CC}=4.5V$	-	10	19	ns
			$V_{CC}=5.0V$; $C_L=15pF$	-	8	-	ns
			$V_{CC}=6.0V$	-	8	16	ns
nOE to nY enable time	t_{en}	see Figure 6	$V_{CC}=2.0V$	-	44	150	ns
			$V_{CC}=4.5V$	-	16	30	ns
			$V_{CC}=6.0V$	-	13	26	ns
nOE to nY disable time	t_{dis}	see Figure 6	$V_{CC}=2.0V$	-	55	150	ns
			$V_{CC}=4.5V$	-	20	30	ns
			$V_{CC}=6.0V$	-	16	26	ns
transition time	t_t	see Figure 5	$V_{CC}=2.0V$	-	14	60	ns
			$V_{CC}=4.5V$	-	5	12	ns
			$V_{CC}=6.0V$	-	4	10	ns
power dissipation capacitance	C_{PD}	per buffer; $V_I=GND$ to V_{CC}	-	30	-	pF	
SN74HCT367							
nA to nY propagation delay	t_{pd}	see Figure 5	$V_{CC}=4.5V$	-	14	25	ns
			$V_{CC}=5.0V$; $C_L=15pF$	-	11	-	ns
nOE to nY enable time	t_{en}	$V_{CC}=4.5V$; see Figure 6	-	16	35	ns	
nOE to nY disable time	t_{dis}	$V_{CC}=4.5V$; see Figure 6	-	21	35	ns	
transition time	t_t	$V_{CC}=4.5V$; see Figure 5	-	5	12	ns	
power dissipation capacitance	C_{PD}	per buffer; $V_I=GND$ to $V_{CC}-1.5V$	-	32	-	pF	

Note:

- [1] t_{pd} is the same as t_{PLH} and t_{PHL} .
- [2] t_{en} is the same as t_{PZL} and t_{PZH} .
- [3] t_{dis} is the same as t_{PLZ} and t_{PHZ} .
- [4] t_t is the same as t_{THL} and t_{TLH} .
- [5] C_{PD} is used to determine the dynamic power dissipation (P_D in uW).

$$P_D = C_{PD} \times V_{CC}^2 \times f_i \times N + \sum (C_L \times V_{CC}^2 \times f_o)$$

f_i =input frequency in MHz;

f_o =output frequency in MHz;

C_L =output load capacitance in pF;

V_{CC} =supply voltage in V;

N =number of inputs switching;

$\sum (C_L \times V_{CC}^2 \times f_o)$ =sum of outputs.



3.3.5、AC Characteristics 2

($T_{amb}=-40^{\circ}\text{C}$ to $+85^{\circ}\text{C}$, $\text{GND}=0\text{V}$, $C_L=50\text{pF}$, unless otherwise specified.)

Parameter	Symbol	Conditions	Min.	Typ.	Max.	Unit	
SN74HC367							
nA to nY propagation delay	t_{pd}	see Figure 5	$V_{CC}=2.0\text{V}$	-	-	120	ns
			$V_{CC}=4.5\text{V}$	-	-	24	ns
			$V_{CC}=6.0\text{V}$	-	-	20	ns
nOE to nY enable time	t_{en}	see Figure 6	$V_{CC}=2.0\text{V}$	-	-	190	ns
			$V_{CC}=4.5\text{V}$	-	-	38	ns
			$V_{CC}=6.0\text{V}$	-	-	33	ns
nOE to nY disable time	t_{dis}	see Figure 6	$V_{CC}=2.0\text{V}$	-	-	190	ns
			$V_{CC}=4.5\text{V}$	-	-	38	ns
			$V_{CC}=6.0\text{V}$	-	-	33	ns
transition time	t_t	see Figure 5	$V_{CC}=2.0\text{V}$	-	-	75	ns
			$V_{CC}=4.5\text{V}$	-	-	15	ns
			$V_{CC}=6.0\text{V}$	-	-	13	ns
SN74HCT367							
nA to nY propagation delay	t_{pd}	see Figure 5	$V_{CC}=4.5\text{V}$	-	-	31	ns
nOE to nY enable time	t_{en}	$V_{CC}=4.5\text{V}$; see Figure 6		-	-	44	ns
nOE to nY disable time	t_{dis}	$V_{CC}=4.5\text{V}$; see Figure 6		-	-	44	ns
transition time	t_t	$V_{CC}=4.5\text{V}$; see Figure 5		-	-	15	ns

Note:

[1] t_{pd} is the same as t_{PLH} and t_{PHL} .

[2] t_{en} is the same as t_{PZL} and t_{PZH} .

[3] t_{dis} is the same as t_{PLZ} and t_{PHZ} .

[4] t_t is the same as t_{THL} and t_{TLH} .



3.3.6、AC Characteristics 3

($T_{amb} = -40^{\circ}\text{C}$ to $+125^{\circ}\text{C}$, $GND = 0\text{V}$, $C_L = 50\text{pF}$, unless otherwise specified.)

Parameter	Symbol	Conditions	Min.	Typ.	Max.	Unit	
SN74HC367							
nA to nY propagation delay	t_{pd}	see Figure 5	$V_{CC} = 2.0\text{V}$	-	-	145	ns
			$V_{CC} = 4.5\text{V}$	-	-	29	ns
			$V_{CC} = 6.0\text{V}$	-	-	25	ns
nOE to nY enable time	t_{en}	see Figure 6	$V_{CC} = 2.0\text{V}$	-	-	225	ns
			$V_{CC} = 4.5\text{V}$	-	-	45	ns
			$V_{CC} = 6.0\text{V}$	-	-	38	ns
nOE to nY disable time	t_{dis}	see Figure 6	$V_{CC} = 2.0\text{V}$	-	-	225	ns
			$V_{CC} = 4.5\text{V}$	-	-	45	ns
			$V_{CC} = 6.0\text{V}$	-	-	38	ns
transition time	t_t	see Figure 5	$V_{CC} = 2.0\text{V}$	-	-	90	ns
			$V_{CC} = 4.5\text{V}$	-	-	18	ns
			$V_{CC} = 6.0\text{V}$	-	-	15	ns
SN74HCT367							
nA to nY propagation delay	t_{pd}	see Figure 5	$V_{CC} = 4.5\text{V}$	-	-	38	ns
nOE to nY enable time	t_{en}	$V_{CC} = 4.5\text{V}$; see Figure 6		-	-	53	ns
nOE to nY disable time	t_{dis}	$V_{CC} = 4.5\text{V}$; see Figure 6		-	-	53	ns
transition time	t_t	$V_{CC} = 4.5\text{V}$; see Figure 5		-	-	18	ns

Note:

[1] t_{pd} is the same as t_{PLH} and t_{PHL} .

[2] t_{en} is the same as t_{PZL} and t_{PZH} .

[3] t_{dis} is the same as t_{PLZ} and t_{PHZ} .

[4] t_t is the same as t_{THL} and t_{TLH} .



4、Testing Circuit

4.1、AC Testing Circuit

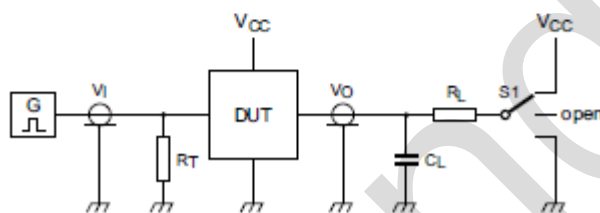
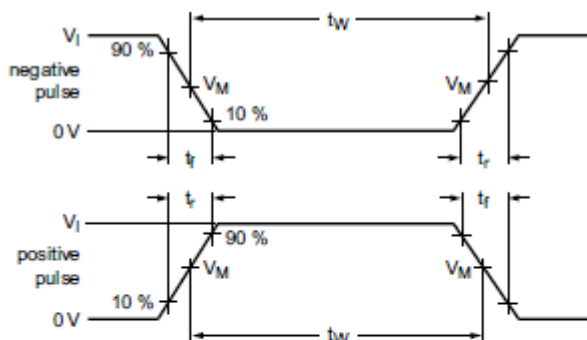

Figure 4. Test circuit for measuring switching times

Definitions for test circuit:

R_L =Load resistance.

C_L =Load capacitance including jig and probe capacitance.

R_T =Termination resistance should be equal to the output impedance Z_o of the pulse generator.

S1=Test selection switch.

4.2、AC Testing Waveforms

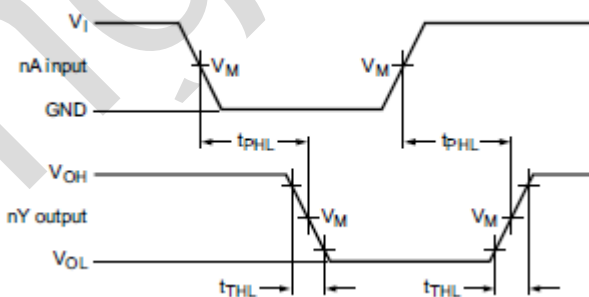

Figure 5. Input (nA) to output (nY) propagation delays and output transition times

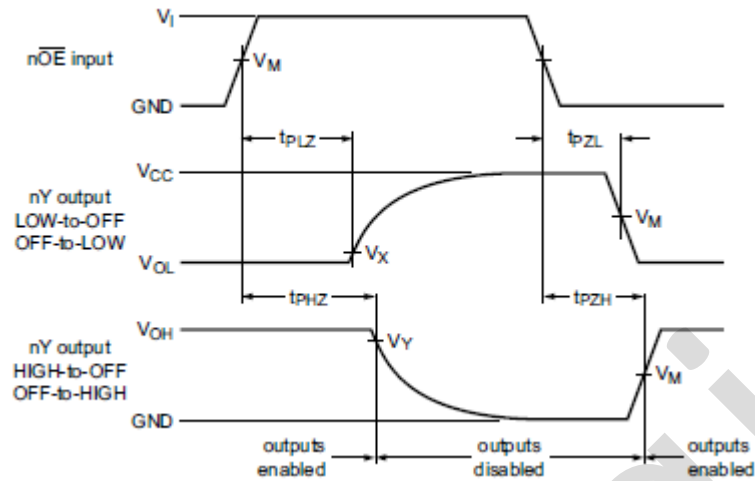

Figure 6. 3-state enable and disable times

4.3、Measurement Points

Type	Input		Output	
	V_M	V_M	V_X	V_Y
SN74HC367	$0.5 \times V_{CC}$	$0.5 \times V_{CC}$	$0.1 \times V_{CC}$	$0.9 \times V_{CC}$
SN74HCT367	1.3V	1.3V	$0.1 \times V_{CC}$	$0.9 \times V_{CC}$

4.4、Test Data

Type	Input		Load		S1 position		
	V_I	t_r, t_f	C_L	R_L	t_{PHL}, t_{PLH}	t_{PZH}, t_{PHZ}	t_{PZL}, t_{PLZ}
SN74HC367	V_{CC}	6ns	15pF, 50pF	1k Ω	open	GND	V_{CC}
SN74HCT367	3V	6ns	15pF, 50pF	1k Ω	open	GND	V_{CC}



5、Package Information

5.1、DIP16

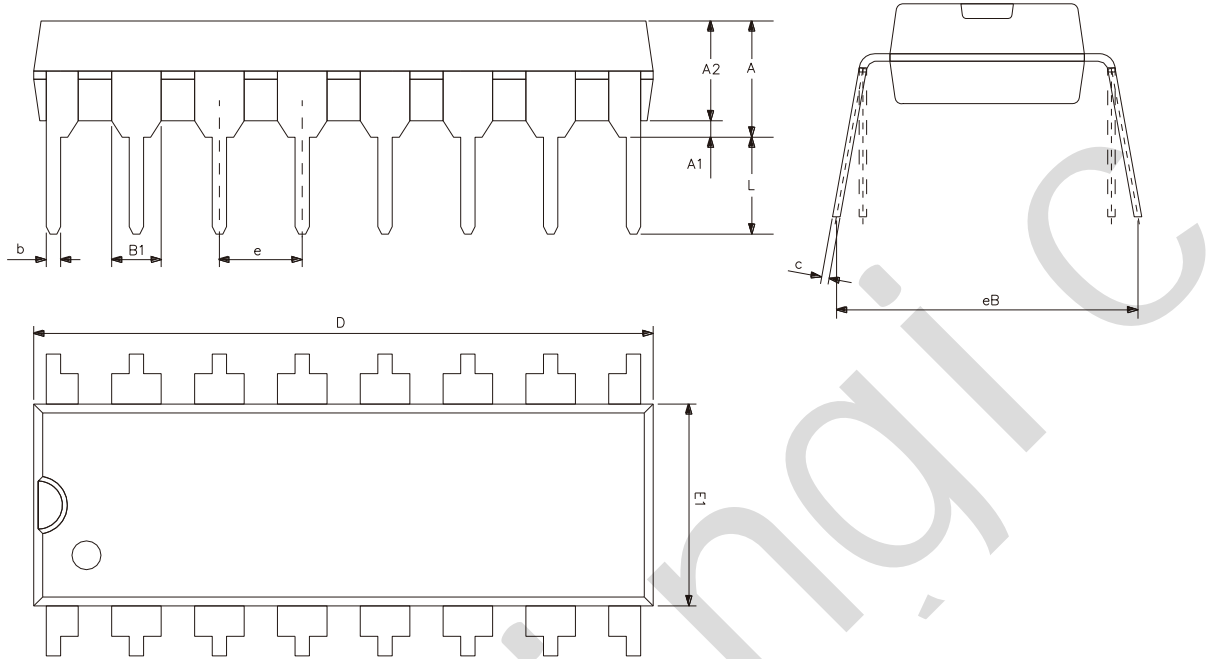

Symbol	Dimensions (mm)	
	Min.	Max.
A2	3.20	3.60
A1	0.51	-
A	3.60	5.33
L	3.00	3.60
b	0.36	0.56
B1	1.52	
D	18.80	19.94
E1	6.20	6.60
e	2.54	
c	0.20	0.36
eB	7.62	9.30



灵星芯微 精芯经营

5.2、SOP16

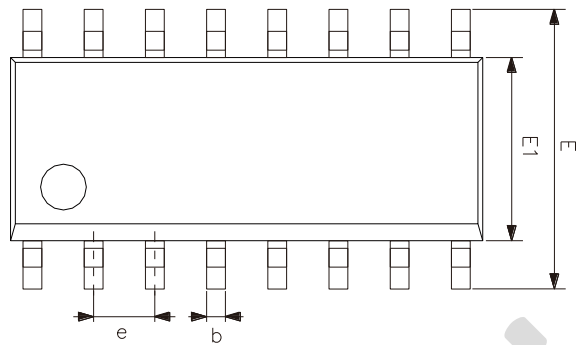
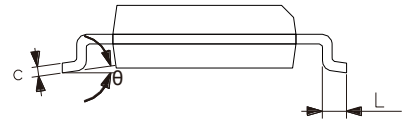
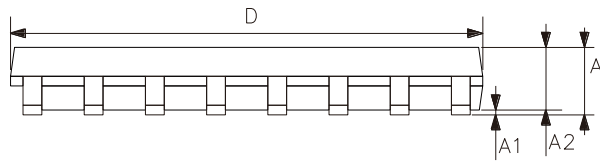

Symbol	Dimensions (mm)	
	Min.	Max.
A	1.35	1.80
A1	0.10	0.25
A2	1.25	1.55
b	0.33	0.51
c	0.19	0.25
D	9.50	10.10
E	5.80	6.30
E1	3.70	4.10
e	1.27	
L	0.35	0.89
θ	0°	8°



灵星芯微 专注经营

5.3、TSSOP16

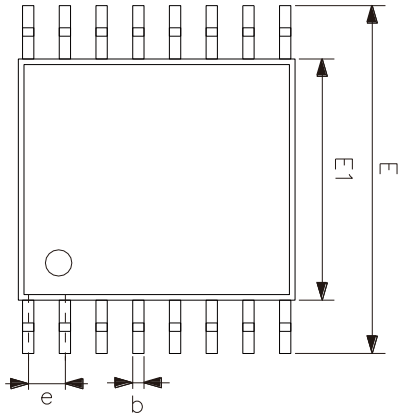
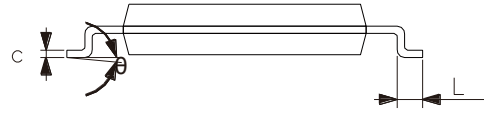
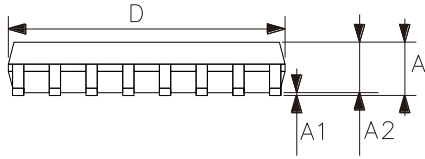

Symbol	Dimensions (mm)	
	Min.	Max.
A	-	1.20
A1	0.05	0.15
A2	0.80	1.05
b	0.19	0.30
c	0.09	0.20
D	4.90	5.10
E1	4.30	4.50
E	6.20	6.60
e	0.65	
L	0.45	0.75
θ	0°	8°



6、 Statements And Notes

6.1、 The name and content of Hazardous substances or Elements in the product

Part name	Hazardous substances or Elements									
	Lead and lead compounds	Mercury and mercury compounds	Cadmium and cadmium compounds	Hexavalent chromium compounds	Polybrominated biphenyls	Polybrominated biphenyl ethers	Dibutyl phthalate	Butylbenzyl phthalate	Di-2-ethylhexyl phthalate	Diisobutyl phthalate
Lead frame	○	○	○	○	○	○	○	○	○	○
Plastic resin	○	○	○	○	○	○	○	○	○	○
Chip	○	○	○	○	○	○	○	○	○	○
The lead	○	○	○	○	○	○	○	○	○	○
Plastic sheet installed	○	○	○	○	○	○	○	○	○	○
explanation	○: Indicates that the content of hazardous substances or elements in the detection limit of the following the SJ/T11363-2006 standard. ×: Indicates that the content of hazardous substances or elements exceeding the SJ/T11363-2006 Standard limit requirements.									

6.2、 Notes

We Recommend you to read this chapter carefully before using this product.

The information in this chapter is provided for reference only and Lingxing disclaims any express or implied warranties, including but not limited to applicability, special application or non-infringement of third party rights.

This product is not suitable for critical equipment such as life-saving, life-sustaining or safety equipment. It is also not suitable for applications that may result in personal injury, death, or serious property or environmental damage due to product malfunction or failure. Lingxing will not be liable for any damages incurred by the customers at their own risk for such applications.

The customer is responsible for conducting all necessary tests Lingxing's application to avoid failure in the application or the application of the customer's third party users. Lingxing does not accept any liability.

The Company reserves the right to change or improve the information published in this chapter at any time. The information in this chapter are subject to change without notice. We recommend the customer to consult our sales staff before purchasing.

Please obtain related materials form Lingxing's regular channels and we are not responsible for its content if it is provided by sources other than our company.

In case of any conflict between the Chinese and English version, the version is subject to the Chinese one.

X-ON Electronics

Largest Supplier of Electrical and Electronic Components

Click to view similar products for [Buffers & Line Drivers](#) category:

Click to view products by [lingxingic](#) manufacturer:

Other Similar products are found below :

[LXV200-024SW](#) [74AUP2G34FW3-7](#) [HEF4043BP](#) [NL17SG125DFT2G](#) [NLU1GT126CMUTCG](#) [CD4041UBE](#) [54FCT240CTDB](#)
[74HCT540N](#) [DS14C88N](#) [070519XB](#) [NL17SZ07P5T5G](#) [74LVC2G17FW4-7](#) [CD4502BE](#) [5962-8982101PA](#) [NL17SH17P5T5G](#)
[74HCT126T14-13](#) [74VHC9126FT\(BJ\)](#) [RHRXH162244K1](#) [74AUP1G34FW5-7](#) [74AUP1G07FW5-7](#) [74LVC1G126FW4-7](#)
[74LVC2G126RA3-7](#) [74LVCE1G125FZ4-7](#) [74AUP1G126FW5-7](#) [54FCT240TLB](#) [74LVCE1G07FZ4-7](#) [NLX3G16DMUTCG](#)
[NLX2G06AMUTCG](#) [LE87100NQCT](#) [LE87285NQC](#) [LE87290YQC](#) [LE87290YQCT](#) [74AUP1G125FW5-7](#) [NLU2G16CMUTCG](#)
[MC74LCX244MN2TWG](#) [NL17SG17P5T5G](#) [NLV74HC125ADR2G](#) [NLVHCT245ADTR2G](#) [NLVVHC1G126DFT2G](#) [EL5623IRZ](#)
[ISL15102AIRZ-T13](#) [ISL1539IRZ-T13](#) [MC100EP17MNG](#) [MC74HCT365ADR2G](#) [MC74LCX244ADTR2G](#) [NL27WZ126US](#) [NL37WZ16US](#)
[NLU1G07MUTCG](#) [NLU2G07MUTCG](#) [NLX3G17BMX1TCG](#)