



SN74HC393/HCT393 (LX) Dual 4-bit Binary Ripple Counter

Product Specification

Specification Revision History:

Version	Date	Description
2023-06-A0	2023-06	New
2023-11-A1	2023-11	Parameter modification



Contents

1、 General Description.....	1
2、 Block Diagram And Pin Description	4
2.1、 Block Diagram	4
2.2、 Pin Configurations	4
2.3、 Pin Description.....	4
2.4、 Function Table	5
3、 Electrical Parameter	5
3.1、 Absolute Maximum Ratings.....	5
3.2、 Recommended Operating Conditions	6
3.3、 Electrical Characteristics.....	6
3.3.1、 DC Characteristics 1	6
3.3.2、 DC Characteristics 2.....	8
3.3.3、 AC Characteristics 1	9
3.3.4、 AC Characteristics 2.....	11
4、 Testing Circuit	12
4.1、 AC Testing Circuit.....	12
4.2、 Test Data	12
4.3、 AC Testing Waveforms.....	13
4.4、 Measurement Points	13
5、 Package Information	14
5.1、 DIP14.....	14
5.2、 SOP14.....	15
5.3、 TSSOP14.....	16
6、 Statements And Notes	17
6.1、 The name and content of Hazardous substances or Elements in the product	17



6.2、Notes.....17

Lingxingic



1、General Description

The SN74HC/HCT393 is a dual 4-stage binary ripple counter.

Features:

- Supply voltage range:
SN74HC393: 2~6V
SN74HCT393: 4.5~5.5V
- Input levels:
SN74HC393: CMOS level
SN74HCT393: TTL level
- Temperature range: -40°C to +125°C
- Packaging information: DIP14/SOP14/TSSOP14

Lingxingic



Ordering Information:

Tube packing specifications:

Part number	Packaging form	Marking code	Tube quantity	Boxed tube quantity	Boxed quantity	Notes
SN74HC393N (LX)	DIP14	SN74HC393N	25 PCS/tube	40 tube/box	1000 PCS/box	Dimensions of plastic enclosure: 19.0mm×6.4mm Pin spacing: 2.54mm
SN74HCT393N (LX)	DIP14	SN74HCT393N	25 PCS/tube	40 tube/box	1000 PCS/box	Dimensions of plastic enclosure: 19.0mm×6.4mm Pin spacing: 2.54mm
SN74HC393DR(LX)	SOP14	74HC393	50 PCS/tube	200 tube/box	10000 PCS/box	Dimensions of plastic enclosure: 8.7mm×3.9mm Pin spacing: 1.27mm
SN74HCT393DR (LX)	SOP14	74HCT393	50 PCS/tube	200 tube/box	10000 PCS/box	Dimensions of plastic enclosure: 8.7mm×3.9mm Pin spacing: 1.27mm
SN74HC393PWR (LX)	TSSOP14	74HC393	96 PCS/tube	200 tube/box	19200 PCS/box	Dimensions of plastic enclosure: 5.0mm×4.4mm Pin spacing: 0.65mm
SN74HCT393PWR (LX)	TSSOP14	74HCT393	96 PCS/tube	200 tube/box	19200 PCS/box	Dimensions of plastic enclosure: 5.0mm×4.4mm Pin spacing: 0.65mm



Reel packing specifications:

Part number	Packaging form	Marking code	Reel quantity	Boxed reel quantity	Notes
SN74HC393DR(LX)	SOP14	HC393	4000 PCS/reel	8000 PCS/box	Dimensions of plastic enclosure: 8.7mm×3.9mm Pin spacing: 1.27mm
SN74HCT393DR(LX)	SOP14	HCT393	4000 PCS/reel	8000 PCS/box	Dimensions of plastic enclosure: 8.7mm×3.9mm Pin spacing: 1.27mm
SN74HC393PWR(LX)	TSSOP14	HC393	5000 PCS/reel	10000 PCS/box	Dimensions of plastic enclosure: 5.0mm×4.4mm Pin spacing: 0.65mm
SN74HCT393PWR(LX)	TSSOP14	HCT393	5000 PCS/reel	10000 PCS/box	Dimensions of plastic enclosure: 5.0mm×4.4mm Pin spacing: 0.65mm

Note : If the physical information is inconsistent with the ordering information, please refer to the actual product.

2、Block Diagram And Pin Description

2.1、Block Diagram

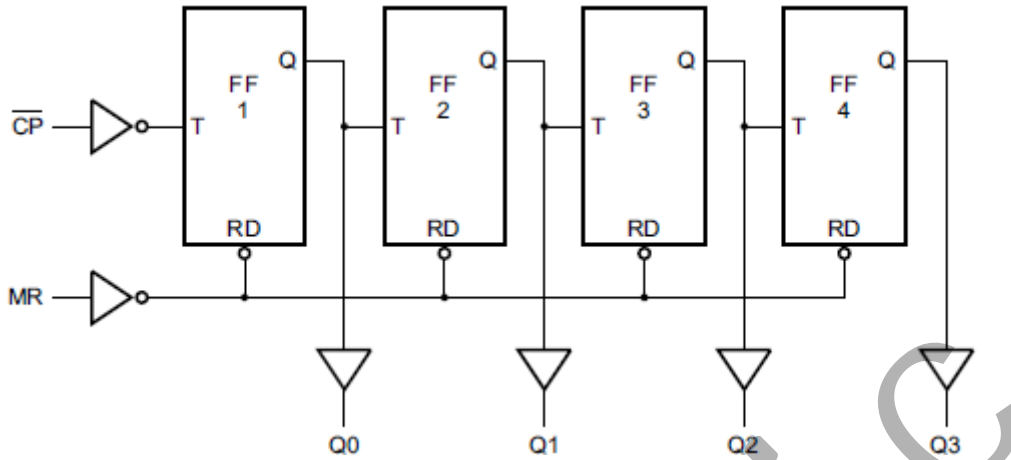
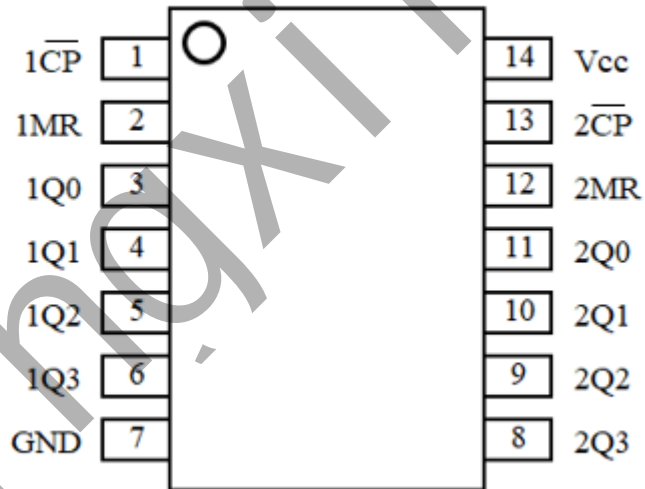

Figure 1. Logic symbol

2.2、Pin Configurations



2.3、Pin Description

Pin No.	Pin Name	Description
1	1CP	clock input (HIGH-to-LOW, edge-triggered)
2	1MR	asynchronous master reset input (active HIGH)
3	1Q0	flip-flop output
4	1Q1	flip-flop output
5	1Q2	flip-flop output
6	1Q3	flip-flop output
7	GND	ground (0V)



8	2Q3	flip-flop output
9	2Q2	flip-flop output
10	2Q1	flip-flop output
11	2Q0	flip-flop output
12	2MR	asynchronous master reset input (active HIGH)
13	2CP	clock input (HIGH-to-LOW, edge-triggered)
14	V _{CC}	supply voltage

2.4、Function Table

Count	Output			
	nQ3	nQ2	nQ1	nQ0
0	L	L	L	L
1	L	L	L	H
2	L	L	H	L
3	L	L	H	H
4	L	H	L	L
5	L	H	L	H
6	L	H	H	L
7	L	H	H	H
8	H	L	L	L
9	H	L	L	H
10	H	L	H	L
11	H	L	H	H
12	H	H	L	L
13	H	H	L	H
14	H	H	H	L
15	H	H	H	H

Note: H=HIGH voltage level; L=LOW voltage level.

3、Electrical Parameter

3.1、Absolute Maximum Ratings

(Voltages are referenced to GND (ground=0V), unless otherwise specified.)

Parameter	Symbol	Conditions	Min.	Max.	Unit	
supply voltage	V _{CC}	-	-0.5	+7	V	
supply current	I _{CC}	-	-	50	mA	
ground current	I _{GND}	-	-50	-	mA	
input clamping current	I _{IK}	V _I < -0.5V or V _I > V _{CC} +0.5V	-	±20	mA	
output clamping current	I _{OK}	V _O < -0.5V or V _O > V _{CC} +0.5V	-	±20	mA	
output current	I _O	-0.5V < V _O < V _{CC} +0.5V	-	±25	mA	
storage temperature	T _{stg}	-	-65	+150	°C	
soldering temperature	T _L	10s	DIP		245	°C



			SOP/TSSOP	260	
--	--	--	-----------	-----	--

3.2、Recommended Operating Conditions

Parameter	Symbol	Conditions	Min.	Typ.	Max.	Unit
SN74HC393						
supply voltage	V_{CC}	-	2.0	5.0	6.0	V
input voltage	V_I	-	0	-	V_{CC}	V
output voltage	V_O	-	0	-	V_{CC}	V
ambient temperature	T_{amb}	-	-40	-	+125	°C
SN74HCT393						
supply voltage	V_{CC}	-	4.5	5.0	5.5	V
input voltage	V_I	-	0	-	V_{CC}	V
output voltage	V_O	-	0	-	V_{CC}	V
ambient temperature	T_{amb}	-	-40	-	+125	°C

3.3、Electrical Characteristics

3.3.1、DC Characteristics 1

($T_{amb}=-40^{\circ}\text{C}$ to $+85^{\circ}\text{C}$, voltages are referenced to GND (ground=0V), unless otherwise specified.)

Parameter	Symbol	V_{CC}	Conditions	Min.	Typ.	Max.	Unit
SN74HC393							
HIGH-level input voltage	V_{IH}	2.0V	-	1.5	1.2	-	V
		4.5V	-	3.15	2.4	-	V
		6.0V	-	4.2	3.2	-	V
LOW-level input voltage	V_{IL}	2.0V	-	-	0.8	0.5	V
		4.5V	-	-	2.1	1.35	V
		6.0V	-	-	2.8	1.8	V
HIGH-level output voltage	V_{OH}	2.0V	$I_O=-20\mu\text{A}$	1.9	2.0	-	V
		4.5V	$I_O=-20\mu\text{A}$	4.4	4.5	-	V
		6.0V	$I_O=-20\mu\text{A}$	5.9	6.0	-	V
		4.5V	$I_O=-4.0\text{mA}$	3.84	4.32	-	V
		6.0V	$I_O=-5.2\text{mA}$	5.34	5.81	-	V
LOW-level output voltage	V_{OL}	2.0V	$I_O=20\mu\text{A}$	-	0	0.1	V
		4.5V	$I_O=20\mu\text{A}$	-	0	0.1	V
		6.0V	$I_O=20\mu\text{A}$	-	0	0.1	V
		4.5V	$I_O=4.0\text{mA}$	-	0.15	0.33	V
		6.0V	$I_O=5.2\text{mA}$	-	0.16	0.33	V
input leakage current	I_I	6.0V	$V_I=V_{CC}$ or GND	-	-	± 1	μA
OFF-state output current	I_{OZ}	6.0V	$V_I=V_{IH}$ or V_{IL} ; $V_O=V_{CC}$ or GND	-	-	± 5	μA
supply current	I_{CC}	6.0V	$V_I=V_{CC}$ or GND; $I_O=0\text{A}$	-	-	80	μA
SN74HCT393							
HIGH-level input voltage	V_{IH}	4.5~5.5V	-	2.0	1.6	-	V



LOW-level input voltage	V_{IL}	4.5~5.5V	-	-	1.2	0.8	V
HIGH-level output voltage	V_{OH}	4.5V	$I_O=-20\mu A$	4.4	4.5	-	V
			$I_O=-4.0mA$	3.84	4.32	-	V
LOW-level output voltage	V_{OL}	4.5V	$I_O=20\mu A$	-	0	0.1	V
			$I_O=4.0mA$	-	0.15	0.33	V
input leakage current	I_I	5.5V	$V_I=V_{CC}$ or GND	-	-	± 1	μA
OFF-state output current	I_{OZ}	5.5V	$V_I=V_{IH}$ or V_{IL} ; $V_O=V_{CC}$ or GND	-	-	± 5	μA
supply current	I_{CC}	6.0V	$V_I=V_{CC}$ or GND; $I_O=0A$	-	-	80	μA
additional supply current	ΔI_{CC}	4.5~5.5V	One input at $V_I=V_{CC}-2.1V$; Other inputs at V_{CC} or GND; $I_O=0A$	-	-	135	μA



3.3.2、DC Characteristics 2

($T_{amb}=-40^{\circ}\text{C}$ to $+125^{\circ}\text{C}$, voltages are referenced to GND (ground=0V), unless otherwise specified.)

Parameter	Symbol	V _{CC}	Conditions	Min.	Typ.	Max.	Unit
SN74HC393							
HIGH-level input voltage	V _{IH}	2.0V	-	1.5	-	-	V
		4.5V	-	3.15	-	-	V
		6.0V	-	4.2	-	-	V
LOW-level input voltage	V _{IL}	2.0V	-	-	-	0.5	V
		4.5V	-	-	-	1.35	V
		6.0V	-	-	-	1.8	V
HIGH-level output voltage	V _{OH}	2.0V	I _O =-20uA	1.9	-	-	V
		4.5V	I _O =-20uA	4.4	-	-	V
		6.0V	I _O =-20uA	5.9	-	-	V
		4.5V	I _O =-4.0mA	3.7	-	-	V
		6.0V	I _O =-5.2mA	5.2	-	-	V
LOW-level output voltage	V _{OL}	2.0V	I _O =20uA	-	-	0.1	V
		4.5V	I _O =20uA	-	-	0.1	V
		6.0V	I _O =20uA	-	-	0.1	V
		4.5V	I _O =4.0mA	-	-	0.4	V
		6.0V	I _O =5.2mA	-	-	0.4	V
input leakage current	I _I	6.0V	V _I =V _{CC} or GND	-	-	±1	uA
OFF-state output current	I _{OZ}	6.0V	V _I =V _{IH} or V _{IL} ; V _O =V _{CC} or GND	-	-	±10	uA
supply current	I _{CC}	6.0V	V _I =V _{CC} or GND; I _O =0A	-	-	160	uA
SN74HCT393							
HIGH-level input voltage	V _{IH}	4.5~5.5V	-	2.0	-	-	V
LOW-level input voltage	V _{IL}	4.5~5.5V	-	-	-	0.8	V
HIGH-level output voltage	V _{OH}	4.5V	I _O =-20uA	4.4	-	-	V
			I _O =-4.0mA	3.7	-	-	V
LOW-level output voltage	V _{OL}	4.5V	I _O =20uA	-	-	0.1	V
			I _O =4.0mA	-	-	0.4	V
input leakage current	I _I	5.5V	V _I =V _{CC} or GND	-	-	±1	uA
OFF-state output current	I _{OZ}	5.5V	V _I =V _{IH} or V _{IL} ; V _O =V _{CC} or GND	-	-	±10	uA
supply current	I _{CC}	6.0V	V _I =V _{CC} or GND; I _O =0A	-	-	160	uA
additional supply current	ΔI _{CC}	4.5~5.5V	One input at V _I =V _{CC} -2.1V; Other inputs at V _{CC} or GND; I _O =0A	-	-	147	uA



3.3.3、AC Characteristics 1

($T_{amb}=-40^{\circ}\text{C}$ to $+85^{\circ}\text{C}$, voltages are referenced to GND (ground=0V), unless otherwise specified.)

Parameter	Symbol	V _{CC}	Conditions	Min.	Typ.	Max.	Unit	
SN74HC393								
nCP to nQ0 propagation delay	t _{PLH} , t _{PHL}	2.0V	C _L =50pF	see Figure 4	-	41	155	ns
		4.5V	C _L =50pF		-	15	31	ns
		5.0V	C _L =15pF		-	12	-	ns
		6.0V	C _L =50pF		-	12	26	ns
nQx to nQ(x+1) propagation delay		2.0V	C _L =50pF		-	14	55	ns
		4.5V	C _L =50pF		-	5	11	ns
		5.0V	C _L =15pF		-	5	-	ns
		6.0V	C _L =50pF		-	4	9	ns
nMR to nQx HIGH to LOW propagation delay	t _{PHL}	2.0V	C _L =50pF	see Figure 5	-	39	175	ns
		4.5V	C _L =50pF		-	14	35	ns
		5.0V	C _L =15pF		-	11	-	ns
		6.0V	C _L =50pF		-	11	30	ns
transition time	t _{THL} , t _{TLH}	2.0V	C _L =50pF	see Figure 4	-	19	95	ns
		4.5V	C _L =50pF		-	7	19	ns
		6.0V	C _L =50pF		-	6	16	ns
nCP HIGH or LOW pulse width	t _w	2.0V	C _L =50pF	see Figure 4	100	17	-	ns
		4.5V	C _L =50pF		20	6	-	ns
		6.0V	C _L =50pF		17	5	-	ns
nMR HIGH pulse width		see Figure 5	2.0V	C _L =50pF	100	19	-	ns
			4.5V	C _L =50pF	20	7	-	ns
			6.0V	C _L =50pF	17	6	-	ns
nMR to nCP recovery time	t _{rec}	2.0V	C _L =50pF	see Figure 5	5	3	-	ns
		4.5V	C _L =50pF		5	1	-	ns
		6.0V	C _L =50pF		5	1	-	ns
maximum clock frequency	f _{clk(max)}	2.0V	C _L =50pF	see Figure 4	5	30	-	MHZ
		4.5V	C _L =50pF		24	90	-	MHZ
		5.0V	C _L =15pF		-	99	-	MHZ
		6.0V	C _L =50pF		28	107	-	MHZ
SN74HCT393								
nCP to nQ0 propagation delay	t _{PLH} , t _{PHL}	4.5V	C _L =50pF	see Figure 4	-	15	31	ns
		5.0V	C _L =15pF		-	20	-	ns
nQx to nQ(x+1) propagation delay		4.5V	C _L =50pF		-	6	13	ns
		5.0V	C _L =15pF		-	6	-	ns
nMR to nQx HIGH to LOW propagation delay	t _{PHL}	4.5V	C _L =50pF	see Figure 5	-	18	40	ns
		5.0V	C _L =15pF		-	15	-	ns
transition time	t _{THL} , t _{TLH}	4.5V	C _L =50pF	see Figure 4	-	7	19	ns
nCP HIGH or	t _w	4.5V	C _L =50pF	see Figure 4	24	11	-	ns



LOW pulse width								
nMR HIGH pulse width		4.5V	$C_L=50\text{pF}$	see Figure 5	20	6	-	ns
nMR to nCP recovery time	trec	4.5V	$C_L=50\text{pF}$	see Figure 5	5	0	-	ns
maximum clock frequency	fclk(max)	4.5V	$C_L=50\text{pF}$	see Figure 4	22	48	-	MHZ
		5.0V	$C_L=15\text{pF}$		-	53	-	MHZ

Lingxing



3.3.4、AC Characteristics 2

($T_{amb} = -40^{\circ}\text{C}$ to $+125^{\circ}\text{C}$, voltages are referenced to GND (ground=0V), unless otherwise specified.)

Parameter	Symbol	V _{CC}	Conditions	Min.	Typ.	Max.	Unit	
SN74HC393								
nCP to nQ0 propagation delay		2.0V	C _L =50pF	see Figure 4	-	-	190	ns
		4.5V	C _L =50pF		-	-	38	ns
		6.0V	C _L =50pF		-	-	32	ns
nQx to nQ(x+1) propagation delay	t _{PLH} , t _{PHL}	2.0V	C _L =50pF	see Figure 4	-	-	70	ns
		4.5V	C _L =50pF		-	-	14	ns
		6.0V	C _L =50pF		-	-	12	ns
nMR to nQx HIGH to LOW propagation delay	t _{PHL}	2.0V	C _L =50pF	see Figure 5	-	-	210	ns
		4.5V	C _L =50pF		-	-	42	ns
		6.0V	C _L =50pF		-	-	36	ns
transition time	t _{THL} , t _{TLH}	2.0V	C _L =50pF	see Figure 4	-	-	110	ns
		4.5V	C _L =50pF		-	-	22	ns
		6.0V	C _L =50pF		-	-	19	ns
nCP HIGH or LOW pulse width	tw	2.0V	C _L =50pF	see Figure 4	120	-	-	ns
		4.5V	C _L =50pF		24	-	-	ns
		6.0V	C _L =50pF		20	-	-	ns
nMR HIGH pulse width		2.0V	C _L =50pF	see Figure 5	120	-	-	ns
		4.5V	C _L =50pF		24	-	-	ns
		6.0V	C _L =50pF		20	-	-	ns
nMR to nCP recovery time	t _{rec}	2.0V	C _L =50pF	see Figure 5	5	-	-	ns
		4.5V	C _L =50pF		5	-	-	ns
		6.0V	C _L =50pF		5	-	-	ns
maximum clock frequency	f _{clk(max)}	2.0V	C _L =50pF	see Figure 4	4	-	-	MHZ
		4.5V	C _L =50pF		20	-	-	MHZ
		6.0V	C _L =50pF		24	-	-	MHZ
SN74HCT393								
nCP to nQ0 propagation delay	t _{PLH} , t _{PHL}	4.5V	C _L =50pF	see Figure 4	-	-	38	ns
nQx to nQ(x+1) propagation delay		4.5V	C _L =50pF		-	-	15	ns
nMR to nQx HIGH to LOW propagation delay	t _{PHL}	4.5V	C _L =50pF	see Figure 5	-	-	48	ns
transition time	t _{THL} , t _{TLH}	4.5V	C _L =50pF	see Figure 4	-	-	22	ns
nCP HIGH or LOW pulse width	tw	4.5V	C _L =50pF	see Figure 4	29	-	-	ns
nMR HIGH pulse width		4.5V	C _L =50pF	see Figure 5	24	-	-	ns



nMR to nCP recovery time	trec	4.5V	$C_L=50\text{pF}$	see Figure 5	5	-	-	ns
maximum clock frequency	fclk(max)	4.5V	$C_L=50\text{pF}$	see Figure 4	18	-	-	MHZ

4、Testing Circuit

4.1、AC Testing Circuit

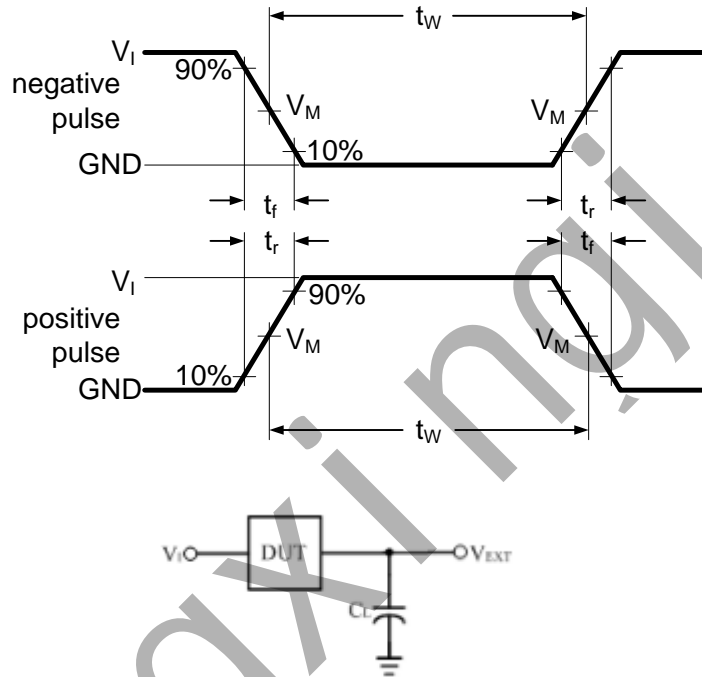

Figure 3. Test circuit for measuring switching times

C_L includes probe and jig capacitance.

4.2、Test Data

Type	Input		Load	V_{EXT}		
	V_I	$t_r = t_f$	C_L	t_{PLH}/t_{PHL}	t_{PLZ}/t_{PZL}	t_{PHZ}/t_{PZH}
SN74HC393	V_{CC}	6.0ns	15pF, 50pF	Open	V_{CC}	GND
SN74HCT393	3.0V	6.0ns	15pF, 50pF	Open	V_{CC}	GND

4.3、AC Testing Waveforms

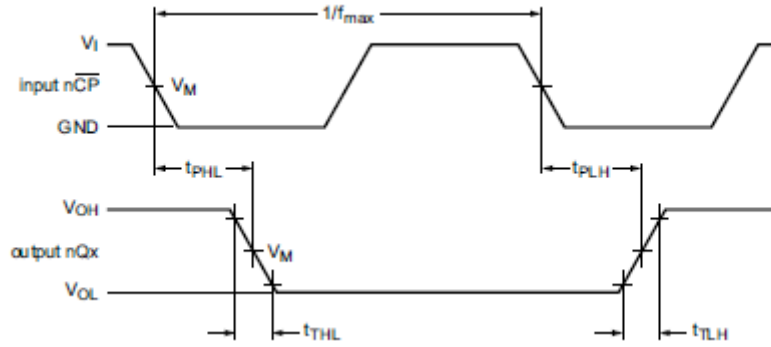

Figure 4. Propagation delay, output transition time

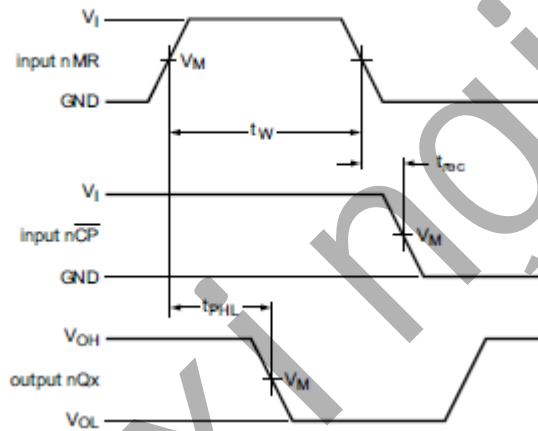

Figure 5. Propagation delays clock (nCP) to output (nQx), pulse width master reset (nMR), and recovery time master reset (nMR) to clock (nCP)

4.4、Measurement Points

Type	Input	Output
	V_M	V_M
SN74HC393	$0.5 \times V_{CC}$	$0.5 \times V_{CC}$
SN74HCT393	1.3V	1.3V



5、Package Information

5.1、DIP14

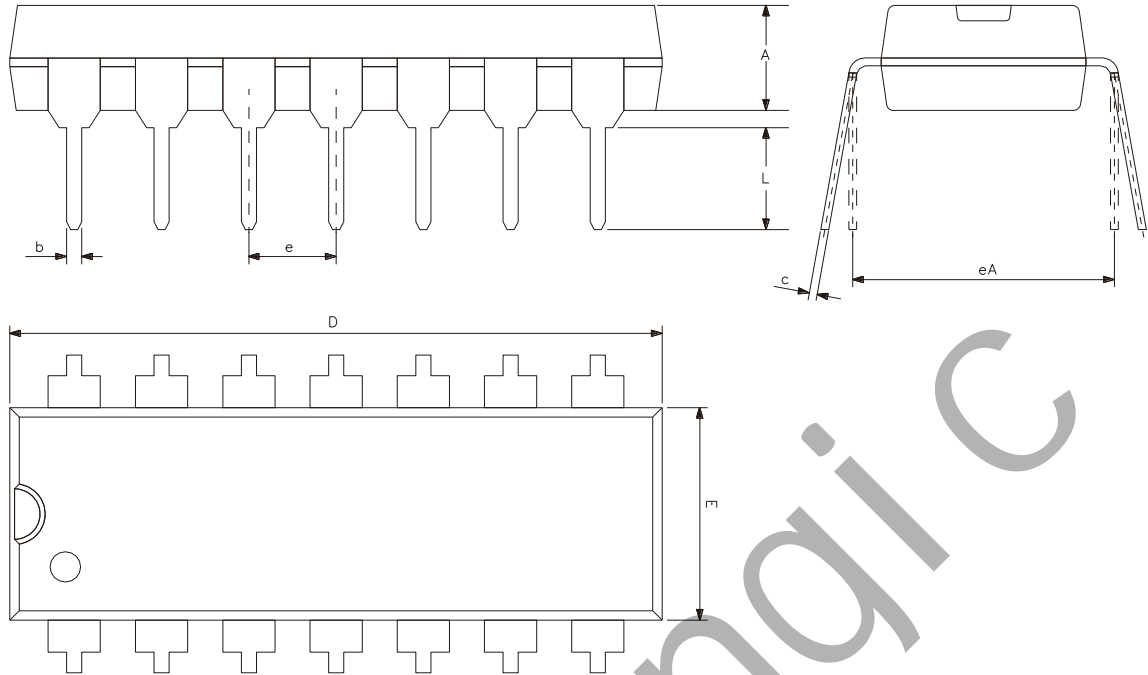

Symbol	Dimensions (mm)	
	Min.	Max.
A	3.05	3.60
b	0.33	0.56
c	0.20	0.36
D	18.80	19.40
E	6.20	6.60
e	2.54	
eA	7.62	10.90
L	2.92	-



5.2、SOP14

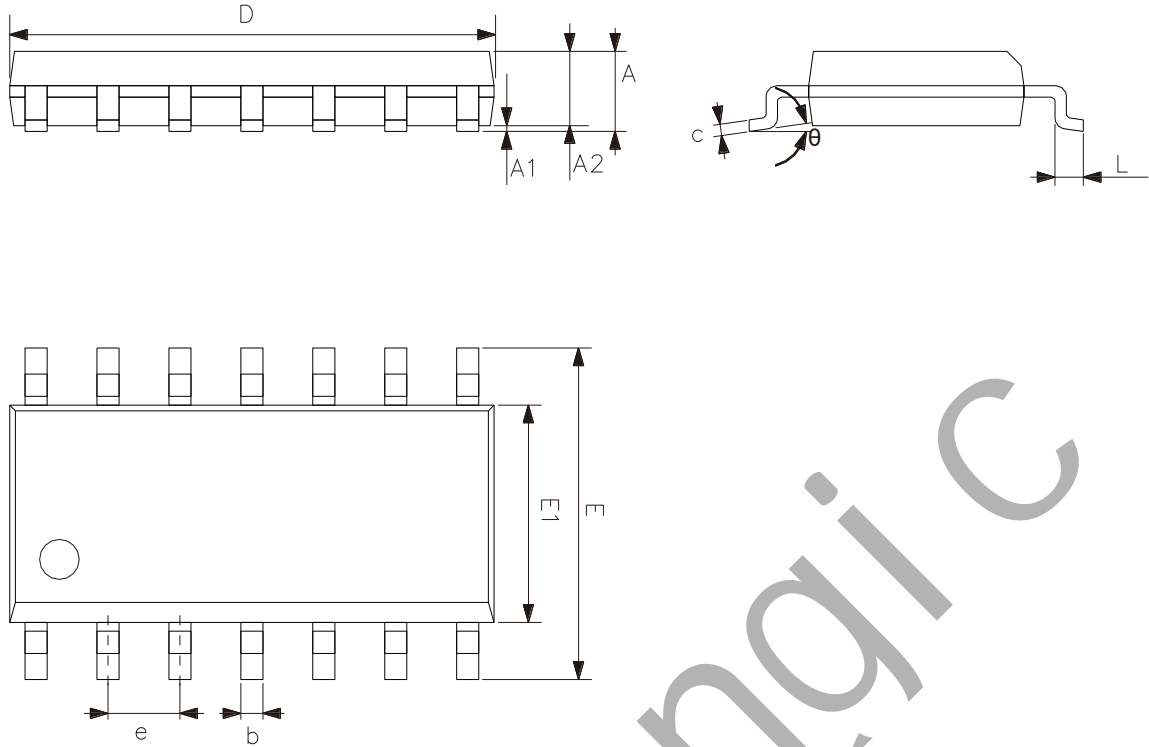

Symbol	Dimensions (mm)	
	Min.	Max.
A	1.50	1.75
A1	0.05	0.25
A2	1.30	-
b	0.33	0.50
c	0.19	0.25
D	8.43	8.76
E	5.80	6.25
E1	3.75	4.00
e	1.27	
L	0.40	0.89
θ	0°	8°



5.3、TSSOP14

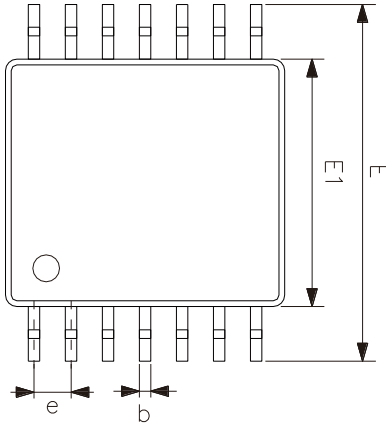
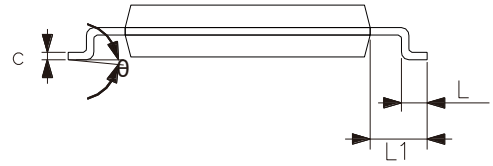
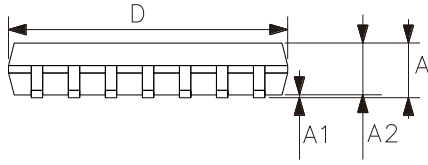

Symbol	Dimensions (mm)	
	Min.	Max.
A	-	1.20
A1	0.05	0.15
A2	0.80	1.05
b	0.19	0.30
c	0.09	0.20
D	4.90	5.10
E1	4.30	4.50
E	6.20	6.60
e	0.65	
L	0.45	0.75
L1	1.00	
θ	0°	8°



6、 Statements And Notes

6.1、 The name and content of Hazardous substances or Elements in the product

Part name	Hazardous substances or Elements									
	Lead and lead compounds	Mercury and mercury compounds	Cadmium and cadmium compounds	Hexavalent chromium compounds	Polybrominated biphenyls	Polybrominated biphenyl ethers	Dibutyl phthalate	Butylbenzyl phthalate	Di-2-ethylhexyl phthalate	Diisobutyl phthalate
Lead frame	○	○	○	○	○	○	○	○	○	○
Plastic resin	○	○	○	○	○	○	○	○	○	○
Chip	○	○	○	○	○	○	○	○	○	○
The lead	○	○	○	○	○	○	○	○	○	○
Plastic sheet installed	○	○	○	○	○	○	○	○	○	○
explanation	○: Indicates that the content of hazardous substances or elements in the detection limit of the following the SJ/T11363-2006 standard. ×: Indicates that the content of hazardous substances or elements exceeding the SJ/T11363-2006 Standard limit requirements.									

6.2、 Notes

We recommend you to read this chapter carefully before using this product.

The information in this chapter is provided for reference only and Lingxing disclaims any express or implied warranties, including but not limited to applicability, special application or non-infringement of third party rights.

This product is not suitable for critical equipment such as life-saving, life-sustaining or safety equipment. It is also not suitable for applications that may result in personal injury, death, or serious property or environmental damage due to product malfunction or failure. Lingxing will not be liable for any damages incurred by the customers at their own risk for such applications.

The customer is responsible for conducting all necessary tests Lingxing's application to avoid failure in the application or the application of the customer's third party users. Lingxing does not accept any liability.

The Company reserves the right to change or improve the information published in this chapter at any time. The information in this chapter are subject to change without notice. We recommend the customer to consult our sales staff before purchasing.

Please obtain related materials form Lingxing's regular channels and we are not responsible for its content if it is provided by sources other than our company.

In case of any conflict between the Chinese and English version, the version is subject to the Chinese one.

X-ON Electronics

Largest Supplier of Electrical and Electronic Components

Click to view similar products for [Counter ICs](#) category:

Click to view products by [lingxingic](#) manufacturer:

Other Similar products are found below :

[CD4018BE](#) [CD4033BE](#) [CD4060BE](#) [CD4040BE](#) [NLV14040BDR2G](#) [RFDIP1607ALM9T21](#) [RFDIP1606L708D1T](#) [RFTIP2510T12A8Q1C](#)
[74HC161DT](#) [CD4028BM/TR](#) [CD4060DM/TR](#) [CD4022BE](#) [CD4060DMT/TR](#) [CD4020BE](#) [CD4060BMT/TR](#) [74HC192M/TR](#)
[CD4020BMT/TR](#) [CD4017CMT/TR](#) [74HC193M/TR](#) [CD4017CM/TR](#) [AiP74HC193SA16.TB](#) [CD4518BM/TR](#) [CD4060TA16.TB](#) [CD4060DE](#)
[CD4017CN](#) [CD4017BMT/TR](#) [U74HC4060G-S16-R](#) [CD4017SA.TB](#) [XD74LS160](#) [CD4017BM-MS](#) [CD4022BM/TR](#) [CD4022BMT/TR](#)
[CD4028BDRG](#) [CD4060BDRG](#) [CD4017DA.TB](#) [CD4520BDRG](#) [CD4520BM\(LX\)](#) [CD4518BM\(LX\)](#) [SN74HC393DR\(LX\)](#) [SN74HC393N\(LX\)](#)
[CD4060BM\(LX\)](#) [CD4060BE\(LX\)](#) [CD4518BE\(LX\)](#) [CD4520BE\(LX\)](#) [74VHC393FT\(BJ\)](#) [74VHC161FT\(BJ\)](#) [74VHC163FT\(BJ\)](#)
[74HC4040D.653](#) [74HC4060D.653](#) [74HCT4040D.653](#)