



SN74HC4051 (LX)

8-channel Analog Multiplexer/Demultiplexer

Product Specification

Specification Revision History:

Version	Date	Description
2022-06-A1	2022-06	New



1、General Description

The SN74HC4051 is an 8-channel analog multiplexer/demultiplexer with three address inputs (S1 to S3), an active LOW enable input (\bar{E}), eight independent inputs/outputs (Y0 to Y7) and a common input/output (Z). The device contains eight bidirectional analog switches, each with one side connected to an independent input/output (Y0 to Y7) and the other side connected to a common input/output (Z). With \bar{E} LOW, one of the eight switches is selected (low-impedance ON-state) by S1 to S3. With \bar{E} HIGH, all switches are in the high-impedance OFF-state, independent of S1 to S3. If break before make is needed, then it is necessary to use the enable input.

V_{DD} and V_{SS} are the supply voltage connections for the digital control inputs (S1 to S3, and \bar{E}). The V_{DD} to V_{SS} range is 3V to 9V. The analog inputs/outputs (Y0 to Y7, and Z) can swing between V_{DD} as a positive limit and V_{EE} as a negative limit. $V_{DD}-V_{EE}$ may not exceed 9V. Unused inputs must be connected to V_{DD} , V_{SS} , or another input. For operation as a digital multiplexer/demultiplexer, V_{EE} is connected to V_{SS} (typically ground). V_{EE} and V_{SS} are the supply voltage connections for the switches.

Features:

- Wide supply voltage range from 3V to 9V
- Fully static operation
- 5V and 9V parametric ratings
- Standardized symmetrical output characteristics
- Specified from -40°C to +125°C
- Packaging information: DIP16/SOP16/TSSOP16



Ordering Information:

Tube packing specifications:

Type number	Packaging form	Marking code	Tube quantity	Boxed tube quantity	Boxed quantity	Packing box number	Packing quantity	Notes
SN74HC4051BE(LX)	DIP16	74HC4051	25 PCS/tube	40 tube/box	1000 PCS/box	10 box/pack	10000 PCS/pack	Dimensions of plastic enclosure: 19.0mm×6.4mm Pin spacing: 2.54mm
SN4HC4051D(LX)	SOP16	74HC4051	50 PCS/tube	200 tube/box	10000 PCS/box	5 box/pack	50000 PCS/pack	Dimensions of plastic enclosure: 10.0mm×3.9mm Pin spacing: 1.27mm
SN74HC4051P(LX)	TSSOP16	74HC4051	96 PCS/tube	120 tube/box	19200 PCS/box	10 box/pack	192000 PCS/pack	Dimensions of plastic enclosure: 5.0mm×4.4mm Pin spacing: 0.65mm

Reel packing specifications:

Type number	Packaging form	Marking code	Reel quantity	Boxed reel quantity	Packing quantity	Notes
SN74HC4051DR(LX)	SOP16(1)	74HC4051	2500 PCS/reel	5000 PCS/box	20000 PCS/pack	Dimensions of plastic enclosure: 10.0mm×3.9mm Pin spacing:1.27mm
SN74HC4051DR(LX)	SOP16(2)	74HC4051	2500 PCS/reel	2500 PCS/box	40000 PCS/pack	Dimensions of plastic enclosure: 10.0mm×3.9mm Pin spacing:1.27mm
SN74HC4051PR(LX)	TSSOP16	74HC4051	2500 PCS/reel	5000 PCS/box	40000 PCS/pack	Dimensions of plastic enclosure: 5.0mm×4.4mm Pin spacing:0.65mm

Note: If the physical information is inconsistent with the ordering information, please refer to the actual product.



2、Block Diagram And Pin Description

2.1、Block Diagram

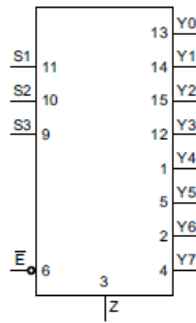

Figure 1. Logic symbol

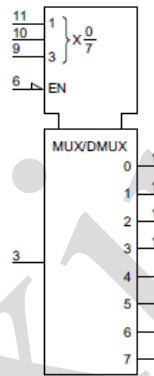

Figure 2. IEC logic symbol

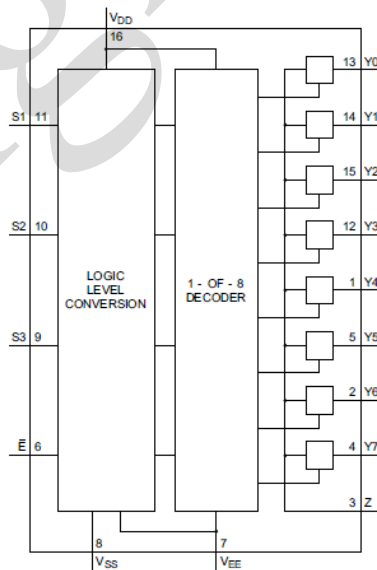

Figure 3. Functional diagram

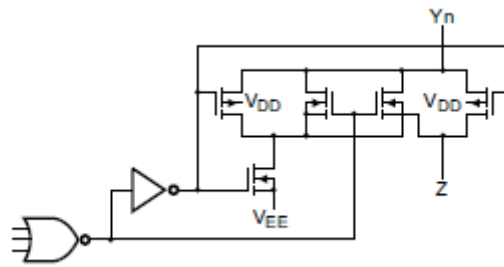

Figure 4. Schematic diagram (one switch)

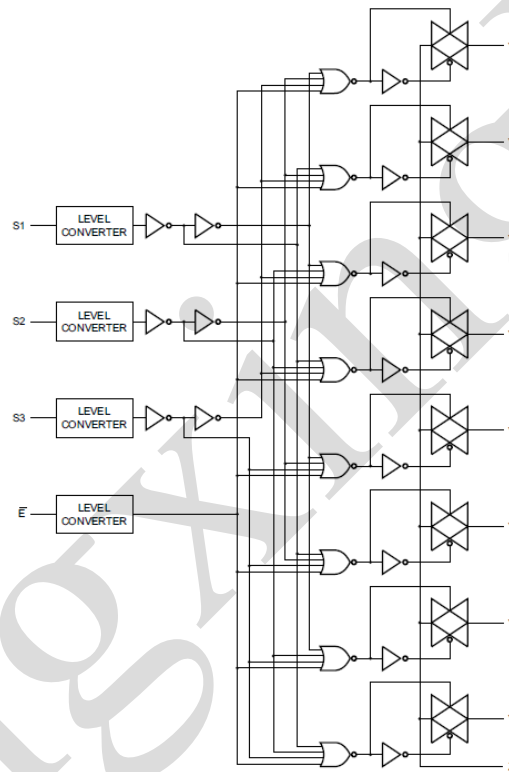
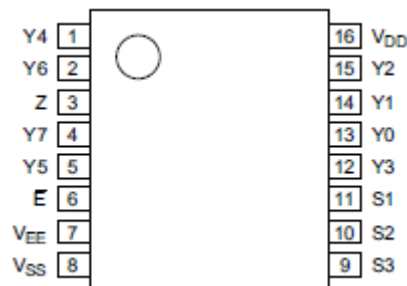

Figure 5. Logic diagram

2.2. Pin Configurations





2.3、Pin Description

Pin No.	Pin Name	Description
1	Y4	independent input or output
2	Y6	independent input or output
3	Z	common output or input
4	Y7	independent input or output
5	Y5	independent input or output
6	\bar{E}	enable input (active LOW)
7	V _{EE}	supply voltage
8	V _{SS}	ground (0V)
9	S3	select input
10	S2	select input
11	S1	select input
12	Y3	independent input or output
13	Y0	independent input or output
14	Y1	independent input or output
15	Y2	independent input or output
16	V _{DD}	supply voltage

2.4、Function Table

Input				Channel ON
\bar{E}	S3	S2	S1	
L	L	L	L	Y0 to Z
L	L	L	H	Y1 to Z
L	L	H	L	Y2 to Z
L	L	H	H	Y3 to Z
L	H	L	L	Y4 to Z
L	H	L	H	Y5 to Z
L	H	H	L	Y6 to Z
L	H	H	H	Y7 to Z
H	X	X	X	switches off

Note: H=HIGH voltage level; L=LOW voltage level; X=don't care.



3、Electrical Parameter

3.1、Absolute Maximum Ratings

(Voltages are referenced to V_{SS} (ground=0V), unless otherwise specified.)

Parameter	Symbol	Conditions	Min.	Max.	Unit
supply voltage	V_{DD}	-	-0.5	+12	V
Power Supply Voltage	V_{EE}	-	-12	+0.5	V
input clamping current	I_{IK}	$V_I < 0.5V$ or $V_I > V_{DD} + 0.5V$	-	± 10	mA
switch current	I	-	-	± 10	mA
input voltage	V_I	all inputs	-0.5	$V_{DD} + 0.5$	V
storage temperature	T_{stg}	-	-65	+150	$^{\circ}C$
total power dissipation	P_{tot}	-	-	500	mW
device dissipation	P	per output transistor	-	100	mW
Soldering temperature	T_L	10s	DIP	245	$^{\circ}C$
			SOP	250	$^{\circ}C$

Note:

[1] For DIP16 packages: above $70^{\circ}C$ the value of P_{tot} derates linearly with 12mW/K.

[2] For SOP16 packages: above $70^{\circ}C$ the value of P_{tot} derates linearly with 8mW/K.

[3] For (T)SSOP16 packages: above $60^{\circ}C$ the value of P_{tot} derates linearly with 5.5mW/K.

3.2、Recommended Operating Conditions

($T_{amb} = 25^{\circ}C$; $R_L = 10k\Omega$; $C_L = 50pF$; $\bar{E} = V_{DD}$; $V_{is} = V_{DD} = 5V$.)

Parameter	Symbol	Conditions	Min.	Typ.	Max.	Unit
supply voltage	V_{DD}	-	3	5	9	V
ambient temperature	T_{amb}	in free air	-40	-	+85	$^{\circ}C$
supply voltage	V_{EE}	-	-6.0	-	0	V
supply voltage	$V_{DD} - V_{EE}$	-	3.0	-	9.0	V
input voltage	V_I	-	0	-	V_{DD}	V
Disable output time (High level \rightarrow turn off)	t_{PHZ}	\bar{E} to Z or \bar{E} to Y_n	-	85	170	ns
Disable output time (Low level \rightarrow turn off)	t_{PLZ}	\bar{E} to Z or \bar{E} to Y_n	-	115	230	ns
Enable output time (turn off \rightarrow high/low level)	t_{PZH}, t_{PZL}	-	-	40	80	ns
input capacitance	C_I	-	-	-	7.5	pF



3.3、Electrical Characteristics

3.3.1、DC Characteristics 1

($T_{amb}=25^{\circ}\text{C}$, voltages are referenced to V_{SS} (ground=0V), unless otherwise specified.)

Parameter	Symbol	Conditions (V)		$T_{amb}=25^{\circ}\text{C}$			Unit
				Min.	Typ.	Max.	
supply current	I_{DD}	$V_I=V_{DD}$ or $V_{SS}, I_O=0\text{A}$	$V_{DD}=5\text{V}$	-	-	20	μA
			$V_{DD}=9\text{V}$	-	-	40	μA
HIGH-level input voltage	V_{IH}	$ I_O <1\mu\text{A}$	$V_{DD}=5\text{V}, V_O=0.5\text{V}$ or 4.5V	3.5	-	-	V
			$V_{DD}=9\text{V}, V_O=0.5\text{V}$ or 8V	7.0	-	-	V
LOW-level input voltage	V_{IL}	$ I_O <1\mu\text{A}$	$V_{DD}=5\text{V}, V_O=0.5\text{V}$ or 4.5V	-	-	1.5	V
			$V_{DD}=9\text{V}, V_O=0.5\text{V}$ or 8V	-	-	3.0	V
input leakage current	I_I	$V_I=0\text{V}$ or $9\text{V}, V_{DD}=9\text{V}$		-	-	0.3	μA
3 state output leakage current	I_{OZ}	$V_{DD}=9\text{V}$	output to V_{DD}	-	-	1.6	μA
			output to V_{SS}	-	-	-1.6	μA
ON resistance (rail)	R_{ON}	$V_{IS}=0\text{V}$ to $V_{DD}-V_{EE}$	$V_{DD}-V_{EE}=5\text{V}$	-	350	2500	Ω
			$V_{DD}-V_{EE}=9\text{V}$	-	80	245	Ω
		$V_{IS}=0\text{V}$	$V_{DD}-V_{EE}=5\text{V}$	-	115	340	Ω
			$V_{DD}-V_{EE}=9\text{V}$	-	50	160	Ω
		$V_{IS}=V_{DD}-V_{EE}$	$V_{DD}-V_{EE}=5\text{V}$	-	120	365	Ω
			$V_{DD}-V_{EE}=9\text{V}$	-	65	200	Ω
ON resistance mismatch between channels	ΔR_{ON}	$V_{IS}=0\text{V}$ to $V_{DD}-V_{EE}$	$V_{DD}-V_{EE}=5\text{V}$	-	25	-	Ω
			$V_{DD}-V_{EE}=9\text{V}$	-	10	-	Ω
OFF-state leakage current	$I_{S(OFF)}$	$V_{SS}=V_{EE}, V_{DD}-V_{EE}=9\text{V}$	all channel off; $\bar{E}=V_{DD}$	-	-	1000	nA
			any channel; $\bar{E}=V_{SS}$	-	-	200	nA

3.3.2、DC Characteristics 2

($T_{amb}=-40^{\circ}\text{C}$ to $+85^{\circ}\text{C}$, voltages are referenced to V_{SS} (ground=0V), unless otherwise specified.)

Parameter	Symbol	Conditions (V)		$T_{amb}=-40^{\circ}\text{C}$		$T_{amb}=+85^{\circ}\text{C}$		Unit
				Min.	Max.	Min.	Max.	
supply current	I_{DD}	$V_I=V_{DD}$ or $V_{SS}, I_O=0\text{A}$	$V_{DD}=5\text{V}$	-	20	-	150	μA
			$V_{DD}=9\text{V}$	-	40	-	300	μA
HIGH-level input voltage	V_{IH}	$ I_O <1\mu\text{A}$	$V_{DD}=5\text{V}, V_O=0.5\text{V}$ or 4.5V	3.5	-	3.5	-	V
			$V_{DD}=9\text{V}, V_O=0.5\text{V}$ or 8V	7.0	-	7.0	-	V
LOW-level input voltage	V_{IL}	$ I_O <1\mu\text{A}$	$V_{DD}=5\text{V}, V_O=0.5\text{V}$ or 4.5V	-	1.5	-	1.5	V
			$V_{DD}=9\text{V}, V_O=0.5\text{V}$ or 8V	-	3.0	-	3.0	V
input leakage current	I_I	$V_I=0\text{V}$ or $9\text{V}, V_{DD}=9\text{V}$		-	0.3	-	1.0	μA



3 state output leakage current	I_{OZ}	$V_{DD}=9V$	output to V_{DD}	-	1.6	-	12.0	μA
			output to V_{SS}	-	-1.6	-	-12.0	μA

3.3.3、AC Characteristics 1

($T_{amb}=25^{\circ}C$, $V_{EE}=V_{SS}=0V$, $t_r, t_f \leq 20ns$, $C_L=50pF$, $R_L=10k\Omega$, unless otherwise specified.)

Parameter	Symbol	Conditions	Min.	Typ.	Max.	Unit	
HIGH to LOW propagation delay time	t_{PHL}	Yn to Z; Z to Yn; see Figure 7	$V_{DD}=5V$	15	-	30	ns
			$V_{DD}=9V$	5	-	10	ns
		Sn to Yn, Z; see Figure 8	$V_{DD}=5V$	150	-	300	ns
			$V_{DD}=9V$	60	-	120	ns
LOW to HIGH propagation delay	t_{PLH}	Yn to Z; Z to Yn; see Figure 7	$V_{DD}=5V$	15	-	30	ns
			$V_{DD}=9V$	5	-	10	ns
		Sn to Yn, Z; see Figure 8	$V_{DD}=5V$	150	-	300	ns
			$V_{DD}=9V$	65	-	130	ns
HIGH to OFF-state propagation delay	t_{PHZ}	\bar{E} to Yn, Z; see Figure 9	$V_{DD}=5V$	120	-	240	ns
			$V_{DD}=9V$	90	-	180	ns
LOW to OFF-state propagation delay	t_{PLZ}	\bar{E} to Yn, Z; see Figure 9	$V_{DD}=5V$	145	-	290	ns
			$V_{DD}=9V$	120	-	240	ns
OFF-state to HIGH propagation delay	t_{PZH}	\bar{E} to Yn, Z; see Figure 9	$V_{DD}=5V$	140	-	280	ns
			$V_{DD}=9V$	55	-	110	ns
OFF-state to LOW propagation delay	t_{PZL}	\bar{E} to Yn, Z; see Figure 9	$V_{DD}=5V$	140	-	280	ns
			$V_{DD}=9V$	55	-	110	ns

3.3.4、AC Characteristics 2

($T_{amb}=25^{\circ}C$, $V_{EE}=V_{SS}=0V$, $V_I=0.5V_{DD}$ (p-p), unless otherwise specified.)

Parameter	Symbol	Conditions	Min.	Typ.	Max.	Unit	
Square wave distortion	d_{sin}	see Figure 10; $R_L=10k\Omega$; $C_L=15pF$; channel ON; $f_i=1kHz$	$V_{DD}=5V$	0.25	-	-	%
			$V_{DD}=9V$	0.04	-	-	%
any two channel crosstalk	f_{ct}	$V_{DD}=9V$, see note2	1	-	-	MHz	
crosstalk voltage (\bar{E} to Sn or Yn to Z)	V_{ct}	see Figure 11; $R_L=10k\Omega$; $C_L=15pF$; \bar{E} or Sn= V_{DD} (square-wave)	50	-	-	mV	
OFF frequency	f_{OFF}	$V_{DD}=9V$, see note3	1	-	-	MHz	
conduction frequency	f_{ON}	$V_{DD}=5V$, see note4	13	-	-	MHz	
		$V_{DD}=9V$, see note4	40	-	-	MHz	



Note:

[1] f_i is biased at $0.5V_{DD}$; $V_I=0.5V_{DD}$ (p-p).

[2] $R_L=1k\Omega$; $20\log V_{os}/V_{is}=-50dB$, see Figure 12.

[3] $R_L=1k\Omega$; $C_L=5pF$, channel off, $20\log V_{os}/V_{is}=-50dB$, see Figure 10.

[4] $R_L=1k\Omega$; $C_L=5pF$, channel on, $20\log V_{os}/V_{is}=-3dB$, see Figure 10.

4、Testing Circuit

4.1、AC Testing Circuit 1

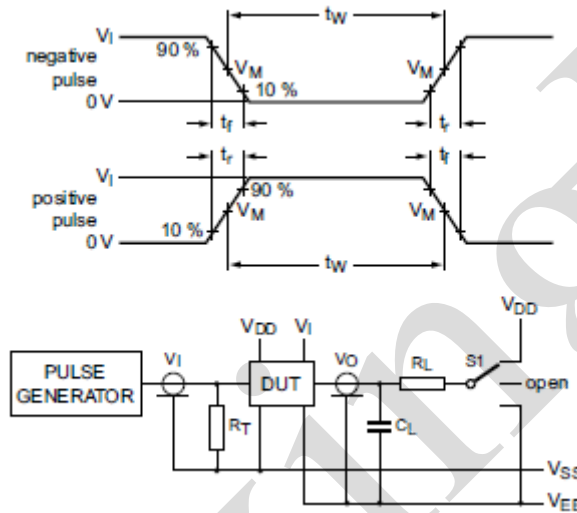

Figure 6. Test circuit for switching times

Definitions for test circuit:

DUT=Device Under Test.

C_L =Load capacitance including jig and probe capacitance.

R_T =Termination resistance should be equal to the output impedance Z_o of the pulse generator.

R_L =Load resistance.

4.2、AC Testing Waveforms

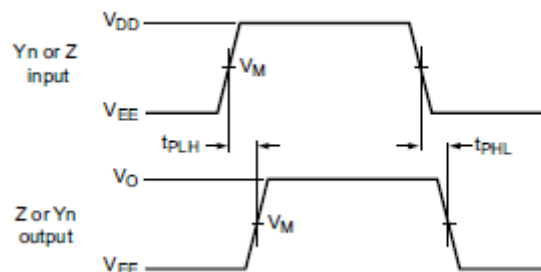

Figure 7. Yn, Z to Z, Yn propagation delays

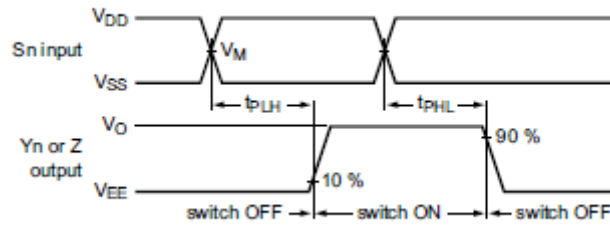

Figure 8. Sn to Yn, Z propagation delays

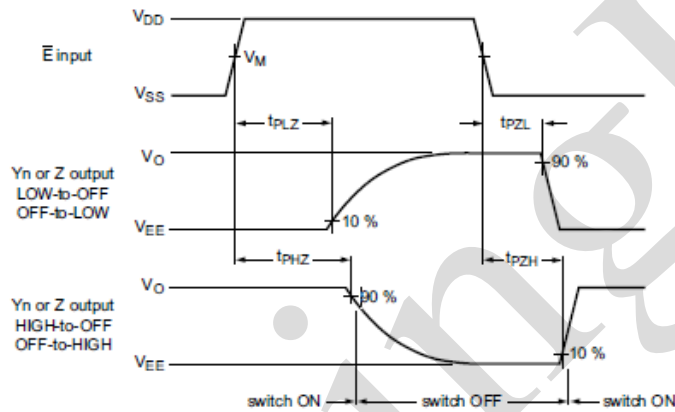

Figure 9. Enable and disable times

4.3、AC Testing Circuit 2

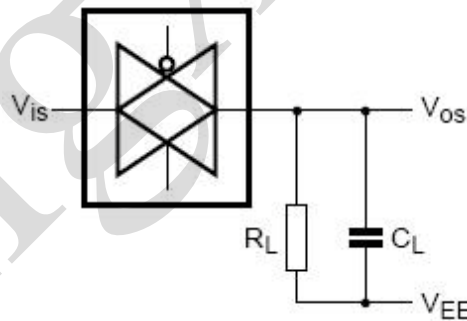

Figure 10. Square wave distortion degree of cut-off frequency and conduction frequency test pattern

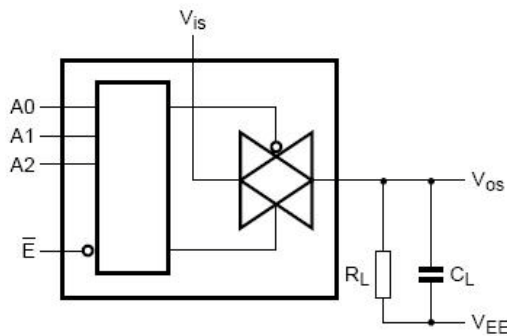

Figure 11. Crosstalk logical input/output test

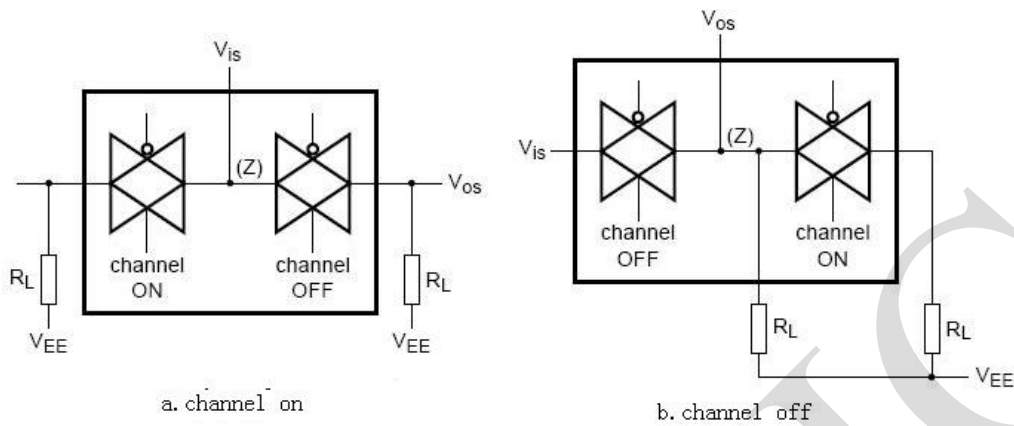

Figure 12. Inter channel Crosstalk

4.4、Measurement Points

Supply voltage	Input	Output
V_{DD}	V_M	V_M
3V to 9V	$0.5 \times V_{DD}$	$0.5 \times V_{DD}$

4.5、Test Data

Test	Input		Load		Switch
	V_{is}	t_r, t_f	C_L	R_L	
t_{PHL}	V_{EE}	20ns	50pF	10k Ω	V_{DD}
t_{PLH}	V_{DD}	20ns	50pF	10k Ω	V_{EE}
t_{PZH}, t_{PHZ}	V_{DD}	20ns	50pF	10k Ω	V_{EE}
t_{PZL}, t_{PLZ}	V_{EE}	20ns	50pF	10k Ω	V_{DD}
others	pulse	20ns	50pF	10k Ω	open



5、Package Information

5.1、DIP16

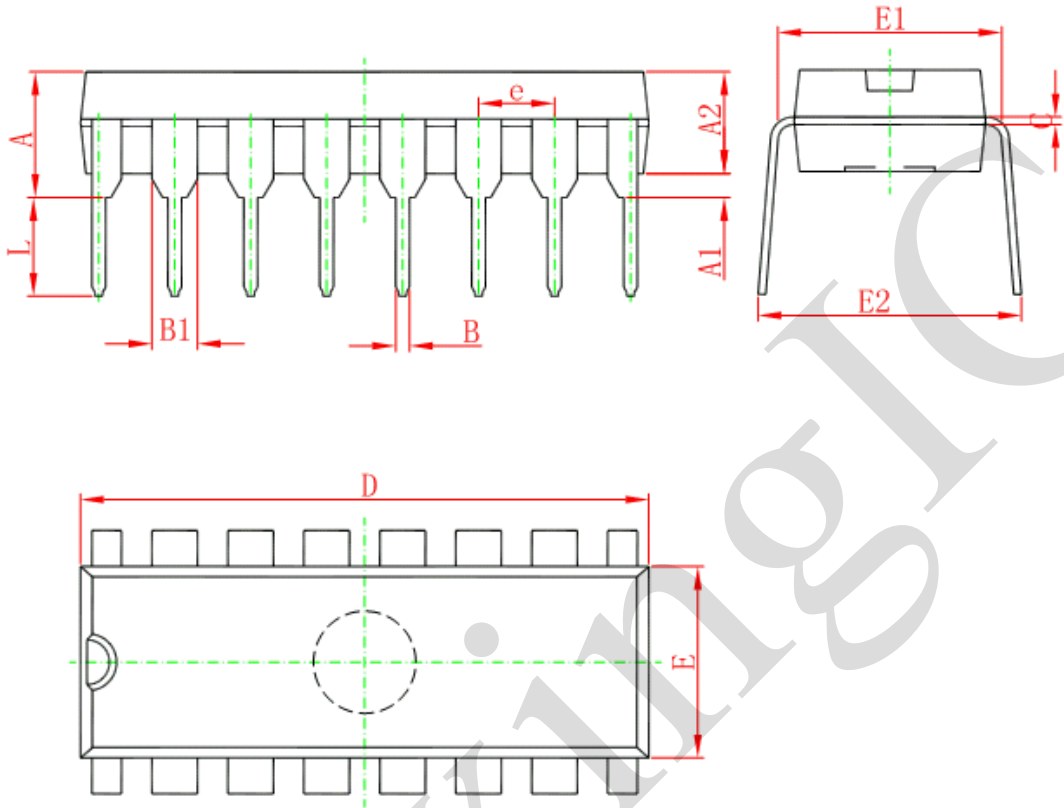

Symbol	Dimensions In Millimeters		Dimensions In Inches	
	Min	Max	Min	Max
A	3.710	4.310	0.146	0.170
A1	0.510		0.020	
A2	3.200	3.600	0.126	0.142
B	0.380	0.570	0.015	0.022
B1	1.524 (BSC)		0.060 (BSC)	
C	0.204	0.360	0.008	0.014
D	18.800	19.200	0.740	0.756
E	6.200	6.600	0.244	0.260
E1	7.320	7.920	0.288	0.312
e	2.540 (BSC)		0.100 (BSC)	
L	3.000	3.600	0.118	0.142
E2	8.400	9.000	0.331	0.354



5.2、SOP16

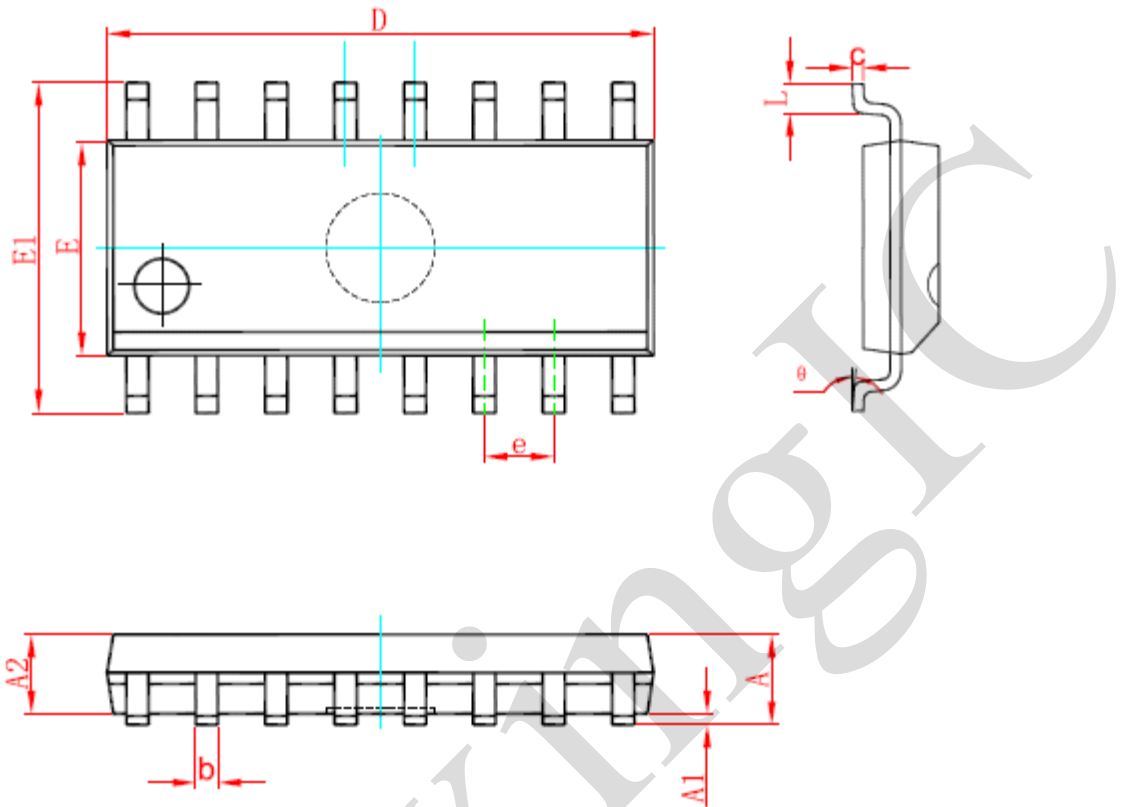

Symbol	Dimensions In Millimeters		Dimensions In Inches	
	Min	Max	Min	Max
A	1.350	1.750	0.053	0.069
A1	0.100	0.250	0.004	0.010
A2	1.350	1.550	0.053	0.061
b	0.330	0.510	0.013	0.020
c	0.170	0.250	0.007	0.010
D	9.800	10.200	0.386	0.402
E	3.800	4.000	0.150	0.157
E1	5.800	6.200	0.228	0.244
e	1.270 (BSC)		0.050 (BSC)	
L	0.400	1.270	0.016	0.050
θ	0°	8°	0°	8°



5.3、TSSOP16

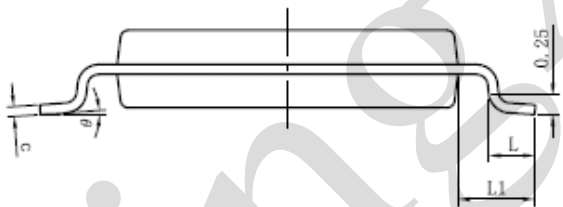
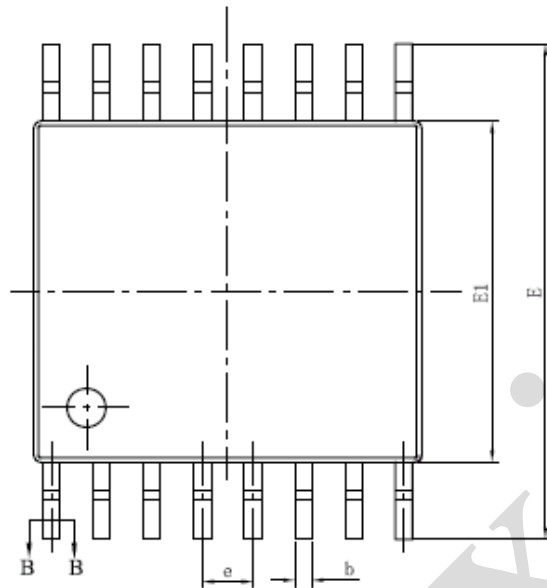
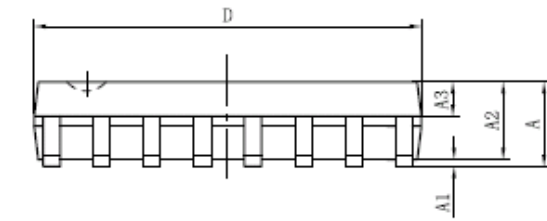

SYMBOL	MILLIMETER	
	MIN	MAX
A	—	1.20
A1	0.05	0.15
A2	0.90	1.05
A3	0.39	0.49
b	0.20	0.30
b1	0.19	0.25
c	0.13	0.19
c1	0.12	0.14
D	4.86	5.06
E	6.20	6.60
e	0.65BSC	
L	0.45	0.75
L1	1.00BSC	
θ	0	8°

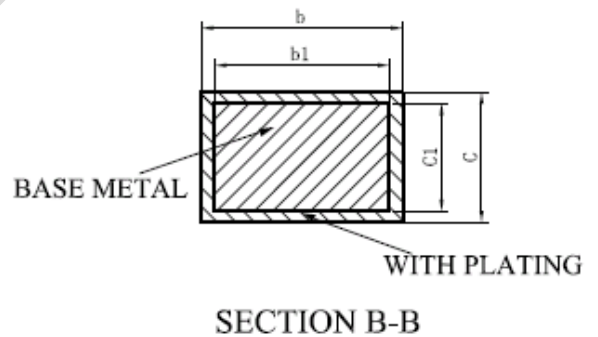



6、 Statements And Notes

6.1、 The name and content of Hazardous substances or Elements in the product

Part name	Hazardous substances or Elements									
	Lead and lead compounds	Mercury and mercury compounds	Cadmium and cadmium compounds	Hexavalent chromium compounds	Polybrominated biphenyls	Polybrominated biphenyl ethers	Dibutyl phthalate	Butylbenzyl phthalate	Di-2-ethylhexyl phthalate	Diisobutyl phthalate
Lead frame	○	○	○	○	○	○	○	○	○	○
Plastic resin	○	○	○	○	○	○	○	○	○	○
Chip	○	○	○	○	○	○	○	○	○	○
The lead	○	○	○	○	○	○	○	○	○	○
Plastic sheet installed	○	○	○	○	○	○	○	○	○	○
explanation	○: Indicates that the content of hazardous substances or elements in the detection limit of the following the SJ/T11363-2006 standard. ×: Indicates that the content of hazardous substances or elements exceeding the SJ/T11363-2006 Standard limit requirements.									

6.2、 Notion

Recommended carefully reading this information before the use of this product;

The information in this document are subject to change without notice;

This information is using to the reference only, the company is not responsible for any loss;

The company is not responsible for the any infringement of the third party patents or other rights of the responsibility.

X-ON Electronics

Largest Supplier of Electrical and Electronic Components

Click to view similar products for [Analogue Switch ICs](#) category:

Click to view products by [lingxingic](#) manufacturer:

Other Similar products are found below :

[FSA3051TMX](#) [NLAS5223BLMNR2G](#) [NLX2G66DMUTCG](#) [TC74HC4066AFTEL](#) [425541DB](#) [DG403DY](#) [099044FB](#) [MAX4762ETB+](#)
[NLAS3799BMNR2G](#) [NLAS5123MNR2G](#) [ISL84684IR](#) [PI5A4157CEX](#) [PI5A4599BCEX](#) [NLAS4717EPFCT1G](#) [PI5A3167CCEX](#)
[SLAS3158MNR2G](#) [PI5A392AQE](#) [ADG714BCPZ-REEL7](#) [DG333ALDW-T1-E3](#) [ISL43113IB](#) [ISL43140IB](#) [ISL43140IBZ-T](#) [ISL43143IR](#)
[ISL43L120IR](#) [ISL43L121IR](#) [ISL43L122IR](#) [ISL43L220IR](#) [ISL43L410IR](#) [ISL43L420IR](#) [ISL43L710IR](#) [ISL43L711IR](#) [ISL43L712IR](#)
[ISL84053IA](#) [ISL84514IB](#) [ISL84516IB](#) [ISL84684IUZ-T](#) [LNLASB3157DFT2G](#) [NLAS324US](#) [NLASTV4599DFT2G](#) [TPW4053-SR](#)
[WAS4642Q-24/TR](#) [WAS4766C-9/TR](#) [WAS7227Q-10/TR](#) [WAS4646C-36/TR](#) [WAS4735Q-16/TR](#) [BL1532TQFN](#) [RS2233YS16](#)
[TMUX1248DCKR](#) [TMUX7236RUMR](#) [ADG836YRMZ-REEL](#)