



灵星芯微 芯片经营

深圳市灵星芯微电子科技有限公司

Shenzhen Lingxing Microelectronics Technology Co., Ltd.

Tab: 835-12-B4

Number: SN74HC/HCT594-AX-LJ-A096EN

# SN74HC/HCT594

## 8-bit Shift Register with Output Register

### Product Specification

#### Specification Revision History:

Version	Date	Description
2023-06-A1	2023-06	New



灵星芯微 精密检测

# Contents

<b>1、 General Description.....</b>	<b>3</b>
<b>2、 Block Diagram And Pin Description.....</b>	<b>6</b>
2.1、 Block Diagram.....	6
2.2、 Pin Configurations.....	6
2.3、 Pin Description .....	6
2.4、 Function Table .....	7
<b>3、 Electrical Parameter .....</b>	<b>8</b>
3.1、 Absolute Maximum Ratings.....	8
3.2、 Recommended Operating Conditions.....	8
3.3、 Electrical Characteristics .....	9
3.3.1、 DC Characteristics 1 .....	9
3.3.2、 DC Characteristics 2 .....	10
3.3.3、 AC Characteristics 1 .....	11
3.3.4、 AC Characteristics 2 .....	13
<b>4、 Testing Circuit.....</b>	<b>15</b>
4.1、 AC Testing Circuit.....	15
4.2、 Test Data.....	15
4.3、 AC Testing Waveforms.....	16
4.4、 Measurement Points .....	19
<b>5、 Package Information.....</b>	<b>20</b>
5.1、 DIP16.....	20
5.2、 SOP16.....	21
5.3、 TSSOP16 .....	22
<b>6、 Statements And Notes.....</b>	<b>23</b>
6.1、 The name and content of Hazardous substances or Elements in the product .....	23
6.2、 Notes.....	23



## 1、General Description

The 74HC594/74HCT594 is an 8-bit serial-in/serial or parallel-out shift register with a storage register.

### Features:

- Supply voltage range:  
SN74HC594: 2~6V  
74HCT594: 4.5~5.5V
- Input levels:  
SN74HC594: CMOS level  
74HCT594: TTL level
- Temperature range: -40°C to +125°C
- Packaging information: DIP16/SOP16/TSSOP16



灵星芯微 肖芯经营

**Ordering Information:****Tube packing specifications:**

Part number	Packaging form	Marking code	Tube quantity	Boxed tube quantity	Boxed quantity	Notes
SN74HC594N	DIP16	SN74HC594N	25 PCS/tube	40 tube/box	1000 PCS/box	Dimensions of plastic enclosure: 19.0mm×6.4mm Pin spacing: 2.54mm
SN74HCT594N	DIP16	SN74HCT594N	25 PCS/tube	40 tube/box	1000 PCS/box	Dimensions of plastic enclosure: 19.0mm×6.4mm Pin spacing: 2.54mm
SN74HC594D	SOP16	SN74HC594	50 PCS/tube	200 tube/box	10000 PCS/box	Dimensions of plastic enclosure: 10.0mm×3.9mm Pin spacing: 1.27mm
SN74HCT594D	SOP16	SN74HCT594	50 PCS/tube	200 tube/box	10000 PCS/box	Dimensions of plastic enclosure: 10.0mm×3.9mm Pin spacing: 1.27mm
SN74HC594PWR	TSSOP16	74HC594	96 PCS/tube	200 tube/box	19200 PCS/box	Dimensions of plastic enclosure: 5.0mm×4.4mm Pin spacing: 0.65mm
SN74HCT594PWR	TSSOP16	74HCT594	96 PCS/tube	200 tube/box	19200 PCS/box	Dimensions of plastic enclosure: 5.0mm×4.4mm Pin spacing: 0.65mm



灵星芯微 集成电路

**Reel packing specifications:**

Part number	Packaging form	Marking code	Reel quantity	Boxed reel quantity	Notes
SN74HC594D	SOP16	74HC594	4000 PCS/reel	8000 PCS/box	Dimensions of plastic enclosure: 10.0mm×3.9mm Pin spacing: 1.27mm
SN74HCT594D	SOP16	74HCT594	4000 PCS/reel	8000 PCS/box	Dimensions of plastic enclosure: 10.0mm×3.9mm Pin spacing: 1.27mm
SN74HC594PWR	TSSOP16	74HC594	5000 PCS/reel	10000 PCS/box	Dimensions of plastic enclosure: 5.0mm×4.4mm Pin spacing: 0.65mm
SN74HCT594PWR	TSSOP16	74HCT594	5000 PCS/reel	10000 PCS/box	Dimensions of plastic enclosure: 5.0mm×4.4mm Pin spacing: 0.65mm

Note: If the physical information is inconsistent with the ordering information, please refer to the actual product.



## 2、Block Diagram And Pin Description

### 2.1、Block Diagram

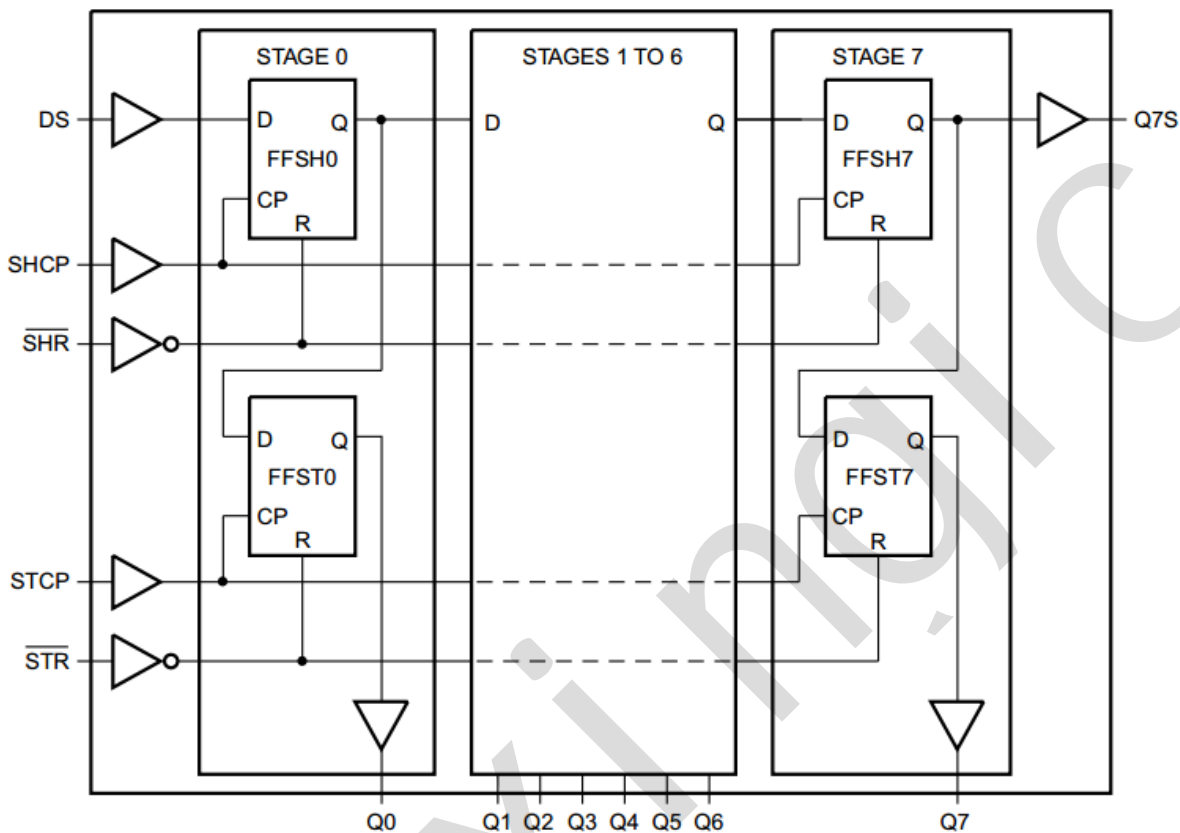
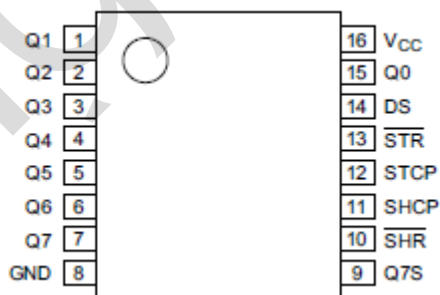

Figure 1. Logic symbol

### 2.2、Pin Configurations



### 2.3、Pin Description

Pin No.	Pin Name	Description
1	Q1	parallel data output
2	Q2	parallel data output
3	Q3	parallel data output
4	Q4	parallel data output
5	Q5	parallel data output
6	Q6	parallel data output



7	Q7	parallel data output
8	GND	ground (0V)
9	Q7S	serial data output t
10	$\overline{\text{SHR}}$	shift register reset (active LOW)
11	SHCP	shift register clock input
12	STCP	storage register clock input
13	$\overline{\text{STR}}$	storage register reset (active LOW)
14	DS	serial data input
15	Q0	parallel data output
16	V <sub>CC</sub>	supply voltage

#### 2.4、Function Table

Input					Function
$\overline{\text{SHR}}$	$\overline{\text{STR}}$	SHCP	STCP	DS	
L	X	X	X	X	Clear shift register
X	L	X	X	X	Clear storage register
H	X	↑	X	H or L	Load DS into shift register stage 0, advance previous stage data to the next stage
X	H	X	↑	X	Transfer shift register data to storage register and outputs Q <sub>n</sub>
H	H	↑	↑	X	Shift register one count pulse ahead of storage register

Note: H=HIGH voltage level; L=LOW voltage level. ↑=LOW-to-HIGH transition .X= don't care



### 3、Electrical Parameter

#### 3.1、Absolute Maximum Ratings

(Voltages are referenced to GND (ground=0V), unless otherwise specified.)

Parameter	Symbol	Conditions	Min.	Max.	Unit
supply voltage	$V_{CC}$	-	-0.5	+7	V
supply current	$I_{CC}$	-	-	50	mA
ground current	$I_{GND}$	-	-50	-	mA
input clamping current	$I_{IK}$	$V_I < -0.5V$ or $V_I > V_{CC}+0.5V$	-	$\pm 20$	mA
output clamping current	$I_{OK}$	$V_O < -0.5V$ or $V_O > V_{CC}+0.5V$	-	$\pm 20$	mA
output current	$I_O$	$-0.5V < V_O < V_{CC}+0.5V$	-	$\pm 25$	mA
storage temperature	$T_{stg}$	-	-65	+150	$^{\circ}C$
soldering temperature	$T_L$	10s	DIP	245	$^{\circ}C$
			SOP/TSSOP	260	

#### 3.2、Recommended Operating Conditions

Parameter	Symbol	Conditions	Min.	Typ.	Max.	Unit
<b>SN74HC594</b>						
supply voltage	$V_{CC}$	-	2.0	5.0	6.0	V
input voltage	$V_I$	-	0	-	$V_{CC}$	V
output voltage	$V_O$	-	0	-	$V_{CC}$	V
ambient temperature	$T_{amb}$	-	-40	-	+125	$^{\circ}C$
<b>SN74HCT594</b>						
supply voltage	$V_{CC}$	-	4.5	5.0	5.5	V
input voltage	$V_I$	-	0	-	$V_{CC}$	V
output voltage	$V_O$	-	0	-	$V_{CC}$	V
ambient temperature	$T_{amb}$	-	-40	-	+125	$^{\circ}C$





### 3.3、Electrical Characteristics

#### 3.3.1、DC Characteristics 1

( $T_{amb} = -40^{\circ}\text{C}$  to  $+85^{\circ}\text{C}$ , voltages are referenced to GND (ground=0V), unless otherwise specified.)

Parameter	Symbol	V <sub>CC</sub>	Conditions	Min.	Typ.	Max.	Unit
<b>SN74HC594</b>							
HIGH-level input voltage	V <sub>IH</sub>	2.0V	-	1.5	1.2	-	V
		4.5V	-	3.15	2.4	-	V
		6.0V	-	4.2	3.2	-	V
LOW-level input voltage	V <sub>IL</sub>	2.0V	-	-	0.8	0.5	V
		4.5V	-	-	2.1	1.35	V
		6.0V	-	-	2.8	1.8	V
HIGH-level output voltage	V <sub>OH</sub>	-	Serial data output Q7S	-	-	-	V
		4.5V	I <sub>O</sub> =-4.0mA	3.84	4.32	-	V
		6.0V	I <sub>O</sub> =-5.2mA	5.34	5.81	-	V
		-	Parallel data outputs	-	-	-	V
		4.5V	I <sub>O</sub> =-6.0mA	3.84	4.32	-	V
		6.0V	I <sub>O</sub> =-7.8mA	5.34	5.81	-	V
LOW-level output voltage	V <sub>OL</sub>	-	Serial data output Q7S	-	-	-	V
		4.5V	I <sub>O</sub> =4.0mA	-	0.15	0.33	V
		6.0V	I <sub>O</sub> =5.2mA	-	0.16	0.33	V
		-	Parallel data outputs	-	-	-	V
		4.5V	I <sub>O</sub> =6.0mA	-	0.15	0.33	V
		6.0V	I <sub>O</sub> =7.8mA	-	0.16	0.33	V
input leakage current	I <sub>I</sub>	6.0V	V <sub>I</sub> =V <sub>CC</sub> or GND	-	-	±2	uA
supply current	I <sub>CC</sub>	6.0V	V <sub>I</sub> =V <sub>CC</sub> or GND; I <sub>O</sub> =0A	-	-	80	uA
<b>SN74HCT594</b>							
HIGH-level input voltage	V <sub>IH</sub>	4.5~5.5V	-	2.0	1.6	-	V
LOW-level input voltage	V <sub>IL</sub>	4.5~5.5V	-	-	1.2	0.8	V
HIGH-level output voltage	V <sub>OH</sub>	4.5V	Serial data output Q7S	-	-	-	V
			I <sub>O</sub> =-4.0mA	3.84	4.32	-	V
		4.5V	Parallel data outputs	-	-	-	V
			I <sub>O</sub> =-6.0mA	3.84	4.32	-	V
LOW-level output voltage	V <sub>OL</sub>	4.5V	Serial data output Q7S	-	-	-	V
			I <sub>O</sub> =4.0mA	-	0.15	0.33	V
		4.5V	Parallel data outputs	-	-	-	V
			I <sub>O</sub> =6.0mA	-	0.16	0.33	V
input leakage current	I <sub>I</sub>	5.5V	V <sub>I</sub> =V <sub>CC</sub> or GND	-	-	±2	uA
supply current	I <sub>CC</sub>	6.0V	V <sub>I</sub> =V <sub>CC</sub> or GND; I <sub>O</sub> =0A	-	-	80	uA
additional supply current	ΔI <sub>CC</sub>	4.5~5.5V	One input at V <sub>I</sub> =V <sub>CC</sub> -2.1V; Other inputs at V <sub>CC</sub> or GND; I <sub>O</sub> =0A	-	-	135	uA



### 3.3.2、DC Characteristics 2

( $T_{amb} = -40^{\circ}\text{C}$  to  $+125^{\circ}\text{C}$ , voltages are referenced to GND (ground=0V), unless otherwise specified.)

Parameter	Symbol	V <sub>CC</sub>	Conditions	Min.	Typ.	Max.	Unit
<b>SN74HC594</b>							
HIGH-level input voltage	V <sub>IH</sub>	2.0V	-	1.5	-	-	V
		4.5V	-	3.15	-	-	V
		6.0V	-	4.2	-	-	V
LOW-level input voltage	V <sub>IL</sub>	2.0V	-	-	-	0.5	V
		4.5V	-	-	-	1.35	V
		6.0V	-	-	-	1.8	V
HIGH-level output voltage	V <sub>OH</sub>		Serial data output Q7S	-	-	-	V
		4.5V	I <sub>O</sub> =-4.0mA	3.7	-	-	V
		6.0V	I <sub>O</sub> =-5.2mA	5.2	-	-	V
			Parelllel data outputs	-	-	-	V
		4.5V	I <sub>O</sub> =-6.0mA	3.7	-	-	V
		6.0V	I <sub>O</sub> =-7.8mA	5.2	-	-	V
LOW-level output voltage	V <sub>OL</sub>		Serial data output Q7S	-	-	-	V
		4.5V	I <sub>O</sub> =4.0mA	-	-	0.4	V
		6.0V	I <sub>O</sub> =5.2mA	-	-	0.4	V
			Parelllel data outputs	-	-	-	V
		4.5V	I <sub>O</sub> =6.0mA	-	-	0.4	V
		6.0V	I <sub>O</sub> =7.8mA	-	-	0.4	V
input leakage current	I <sub>I</sub>	6.0V	V <sub>I</sub> =V <sub>CC</sub> or GND	-	-	±4	uA
supply current	I <sub>CC</sub>	6.0V	V <sub>I</sub> =V <sub>CC</sub> or GND; I <sub>O</sub> =0A	-	-	160	uA
<b>SN74HCT594</b>							
HIGH-level input voltage	V <sub>IH</sub>	4.5~5.5V	-	2.0	-	-	V
LOW-level input voltage	V <sub>IL</sub>	4.5~5.5V	-	-	-	0.8	V
HIGH-level output voltage	V <sub>OH</sub>		Serial data output Q7S	-	-	-	-
		4.5V	I <sub>O</sub> =-4.0mA	3.7	-	-	V
			Parelllel data outputs	-	-	-	-
		4.5V	I <sub>O</sub> =-6.0mA	3.7	-	-	V
LOW-level output voltage	V <sub>OL</sub>		Serial data output Q7S	-	-	-	-
		4.5V	I <sub>O</sub> =4.0mA	-	-	0.4	V
			Parelllel data outputs	-	-	-	-
		4.5V	I <sub>O</sub> =6.0mA	-	-	0.4	V
input leakage current	I <sub>I</sub>	5.5V	V <sub>I</sub> =V <sub>CC</sub> or GND	-	-	±4	uA
supply current	I <sub>CC</sub>	6.0V	V <sub>I</sub> =V <sub>CC</sub> or GND; I <sub>O</sub> =0A	-	-	160	uA
additional supply current	ΔI <sub>CC</sub>	4.5~5.5V	One input at V <sub>I</sub> =V <sub>CC</sub> -2.1V; Other inputs at V <sub>CC</sub> or GND; I <sub>O</sub> =0A	-	-	147	uA



3.3.3、AC Characteristics 1

( $T_{amb} = -40^{\circ}C$  to  $+85^{\circ}C$ , voltages are referenced to GND (ground=0V), unless otherwise specified.)

Parameter	Symbol	V <sub>CC</sub>	Conditions	Min.	Typ.	Max.	Unit		
<b>SN74HC594</b>									
SHCP to Q7S propagation delay	t <sub>PLH</sub> , t <sub>PHL</sub>	2.0V	C <sub>L</sub> =50pF	see Figure 5	-	44	185	ns	
		4.5V	C <sub>L</sub> =50pF		-	16	37	ns	
		5.0V	C <sub>L</sub> =15pF		-	13	-	ns	
		6.0V	C <sub>L</sub> =50pF		-	14	31	ns	
STCP to Qn propagation delay		2.0V	C <sub>L</sub> =50pF	see Figure 6	-	44	185	ns	
		4.5V	C <sub>L</sub> =50pF		-	16	37	ns	
		5.0V	C <sub>L</sub> =15pF		-	13	-	ns	
		6.0V	C <sub>L</sub> =50pF		-	14	31	ns	
SHR to Q7S HIGH to LOW propagation delay	t <sub>PHL</sub>	2.0V	C <sub>L</sub> =50pF	see Figure 9	-	39	185	ns	
		4.5V	C <sub>L</sub> =50pF		-	14	37	ns	
		5.0V	C <sub>L</sub> =15pF		-	11	-	ns	
		6.0V	C <sub>L</sub> =50pF		-	12	31	ns	
STR to Qn HIGH to LOW propagation delay		2.0V	C <sub>L</sub> =50pF	see Figure 10	-	39	155	ns	
		4.5V	C <sub>L</sub> =50pF		-	14	31	ns	
		5.0V	C <sub>L</sub> =15pF		-	11	-	ns	
		6.0V	C <sub>L</sub> =50pF		-	12	26	ns	
Q7S transition time		t <sub>THL</sub> , t <sub>TLH</sub>	2.0V	C <sub>L</sub> =50pF	see Figure 5	-	19	95	ns
			4.5V	C <sub>L</sub> =50pF		-	7	19	ns
			6.0V	C <sub>L</sub> =50pF		-	6	16	ns
Qn transition time			2.0V	C <sub>L</sub> =50pF		-	14	75	ns
	4.5V		C <sub>L</sub> =50pF	-		5	15	ns	
	6.0V		C <sub>L</sub> =50pF	-		4	13	ns	
SHCP(HIGH or LOW) pulse width	t <sub>w</sub>	2.0V	C <sub>L</sub> =50pF	see Figure 5	100	10	-	ns	
		4.5V	C <sub>L</sub> =50pF		20	4	-	ns	
		6.0V	C <sub>L</sub> =50pF		17	3	-	ns	
STCP(HIGH or LOW) pulse width		2.0V	C <sub>L</sub> =50pF	see Figure 6	100	10	-	ns	
		4.5V	C <sub>L</sub> =50pF		20	4	-	ns	
		6.0V	C <sub>L</sub> =50pF		17	3	-	ns	
SHR and STR (HIGH or LOW)		2.0V	C <sub>L</sub> =50pF	see Figure 9 and Figure 10	100	14	-	ns	
		4.5V	C <sub>L</sub> =50pF		20	5	-	ns	
		6.0V	C <sub>L</sub> =50pF		17	4	-	ns	
DS to SHCP set_up time		t <sub>su</sub>	2.0V	C <sub>L</sub> =50pF	see Figure 7	125	10	-	ns
			4.5V	C <sub>L</sub> =50pF		25	4	-	ns
			6.0V	C <sub>L</sub> =50pF		21	3	-	ns
SHR to STCP set_up time	2.0V		C <sub>L</sub> =50pF	see Figure 8	125	14	-	ns	
	4.5V		C <sub>L</sub> =50pF		25	5	-	ns	
	6.0V		C <sub>L</sub> =50pF		21	4	-	ns	
SHCP to STCP set_up time	2.0V		C <sub>L</sub> =50pF	see Figure 6	125	17	-	ns	
	4.5V		C <sub>L</sub> =50pF		25	6	-	ns	
	6.0V		C <sub>L</sub> =50pF		21	5	-	ns	
DS to SHCP	t <sub>h</sub>		2.0V	C <sub>L</sub> =50pF	see Figure 7	30	-8	-	ns



hold time		4.5V	$C_L=50pF$		6	-3	-	ns
		6.0V	$C_L=50pF$		5	-2	-	ns
SHR to SHCP STR to STCP recovery time	trec	2.0V	$C_L=50pF$	see Figure 9 and Figure 10	65	-14	-	ns
		4.5V	$C_L=50pF$		13	-5	-	ns
		6.0V	$C_L=50pF$		11	-4	-	ns
maximum frequency	fmax	2.0V	$C_L=50pF$	see Figure 5 and Figure 6	4.8	30	-	MHz
		4.5V	$C_L=50pF$		24	92	-	MHz
		5.0V	$C_L=15pF$		-	100	-	MHz
		6.0V	$C_L=50pF$		28	109	-	MHz
<b>SN74HCT594</b>								
SHCP to Q7S propagation delay	$t_{PLH}, t_{PHL}$	4.5V	$C_L=50pF$	see Figure 5	-	18	40	ns
		5.0V	$C_L=15pF$		-	15	-	ns
STCP to Qn propagation delay		4.5V	$C_L=50pF$	see Figure 6	-	18	40	ns
		5.0V	$C_L=15pF$		-	15	-	ns
SHR to Q7S HIGH to LOW propagation delay	$t_{PHL}$	4.5V	$C_L=50pF$	see Figure 9	-	17	38	ns
		5.0V	$C_L=15pF$		-	14	-	ns
STR to Qn HIGH to LOW propagation delay		4.5V	$C_L=50pF$	see Figure 10	-	17	38	ns
		5.0V	$C_L=15pF$		-	14	-	ns
Q7S transition time	$t_{THL}, t_{TLH}$	4.5V	$C_L=50pF$	see Figure 5	-	7	19	ns
Qn transition time		4.5V	$C_L=50pF$		-	5	15	ns
SHCP(HIGH or LOW) pulse width	tw	4.5V	$C_L=50pF$	see Figure 5	20	4	-	ns
STCP(HIGH or LOW) pulse width		4.5V	$C_L=50pF$	see Figure 6	20	4	-	ns
SHR and STR (HIGH OR LOW)		4.5V	$C_L=50pF$	see Figure 9 and Figure 10	20	6	-	ns
DS to SHCP Set up time	tsu	4.5V	$C_L=50pF$	see Figure 7	25	4	-	ns
SHR to STCP Set up time		4.5V	$C_L=50pF$	see Figure 8	25	6	-	ns
SHCP to STCP Set up time		4.5V	$C_L=50pF$	see Figure 6	25	7	-	ns
DS to SHCP hold time	th	4.5V	$C_L=50pF$	see Figure 7	6	-3	-	ns
SHR to SHCP STR to STCP recovery time	trec	4.5V	$C_L=50pF$	see Figure 9 and Figure 10	13	-5	-	ns
maximum frequency	fmax	4.5V	$C_L=15pF$	see Figure 5 and Figure 6	24	92	-	MHz



3.3.4、AC Characteristics 2

( $T_{amb} = -40^{\circ}C$  to  $+125^{\circ}C$ , voltages are referenced to GND (ground=0V), unless otherwise specified.)

Parameter	Symbol	V <sub>CC</sub>	Conditions	Min.	Typ.	Max.	Unit	
<b>SN74HC594</b>								
SHCP to Q7S propagation delay	t <sub>PLH</sub> , t <sub>PHL</sub>	2.0V	C <sub>L</sub> =50pF	see Figure 5	-	-	225	ns
		4.5V	C <sub>L</sub> =50pF		-	-	45	ns
		6.0V	C <sub>L</sub> =50pF		-	-	38	ns
STCP to Qn propagation delay		2.0V	C <sub>L</sub> =50pF	see Figure 6	-	-	225	ns
		4.5V	C <sub>L</sub> =50pF		-	-	45	ns
		6.0V	C <sub>L</sub> =50pF		-	-	38	ns
SHR to Q7S HIGH to LOW propagation delay	t <sub>PHL</sub>	2.0V	C <sub>L</sub> =50pF	see Figure 9	-	-	225	ns
		4.5V	C <sub>L</sub> =50pF		-	-	45	ns
		6.0V	C <sub>L</sub> =50pF		-	-	38	ns
STR to Qn HIGH to LOW propagation delay		2.0V	C <sub>L</sub> =50pF	see Figure 10	-	-	185	ns
		4.5V	C <sub>L</sub> =50pF		-	-	37	ns
		6.0V	C <sub>L</sub> =50pF		-	-	31	ns
Q7S transition time	t <sub>THL</sub> , t <sub>TLH</sub>	2.0V	C <sub>L</sub> =50pF	see Figure 5	-	-	110	ns
		4.5V	C <sub>L</sub> =50pF		-	-	22	ns
		6.0V	C <sub>L</sub> =50pF		-	-	19	ns
Qn transition time		2.0V	C <sub>L</sub> =50pF		-	-	90	ns
		4.5V	C <sub>L</sub> =50pF		-	-	18	ns
		6.0V	C <sub>L</sub> =50pF		-	-	15	ns
SHCP(HIGH or LOW) pulse width	t <sub>w</sub>	2.0V	C <sub>L</sub> =50pF	see Figure 5	120	-	-	ns
		4.5V	C <sub>L</sub> =50pF		24	-	-	ns
		6.0V	C <sub>L</sub> =50pF		20	-	-	ns
STCP(HIGH or LOW) pulse width		2.0V	C <sub>L</sub> =50pF	see Figure 6	120	-	-	ns
		4.5V	C <sub>L</sub> =50pF		24	-	-	ns
		6.0V	C <sub>L</sub> =50pF		20	-	-	ns
SHR and STR (HIGH OR LOW)		2.0V	C <sub>L</sub> =50pF	see Figure 9 and Figure 10	120	-	-	ns
		4.5V	C <sub>L</sub> =50pF		24	-	-	ns
		6.0V	C <sub>L</sub> =50pF		20	-	-	ns
DS to SHCP set_up time	t <sub>su</sub>	2.0V	C <sub>L</sub> =50pF	see Figure 7	150	-	-	ns
		4.5V	C <sub>L</sub> =50pF		30	-	-	ns
		6.0V	C <sub>L</sub> =50pF		26	-	-	ns
SHR to STCP set_up time		2.0V	C <sub>L</sub> =50pF	see Figure 8	150	-	-	ns
		4.5V	C <sub>L</sub> =50pF		30	-	-	ns
		6.0V	C <sub>L</sub> =50pF		26	-	-	ns
SHCP to STCP set_up time		2.0V	C <sub>L</sub> =50pF	see Figure 7	150	-	-	ns
		4.5V	C <sub>L</sub> =50pF		30	-	-	ns
		6.0V	C <sub>L</sub> =50pF		26	-	-	ns
DS to SHCP hold time	t <sub>h</sub>	2.0V	C <sub>L</sub> =50pF	see Figure 7	35	-	-	ns
		4.5V	C <sub>L</sub> =50pF		7	-	-	ns
		6.0V	C <sub>L</sub> =50pF		6	-	-	ns
SHR to SHCP	t <sub>rec</sub>	2.0V	C <sub>L</sub> =50pF	see Figure 9	75	-	-	ns



STR to STCP recovery time		4.5V	$C_L=50pF$	and Figure 10	15	-	-	ns
		6.0V	$C_L=50pF$		13	-	-	ns
maximum frequency	fmax	2.0V	$C_L=50pF$	see Figure 5 and Figure 6	4	-	-	MHz
		4.5V	$C_L=50pF$		20	-	-	MHz
		6.0V	$C_L=50pF$		24	-	-	MHz
<b>SN74HCT594</b>								
SHCP to Q7S propagation delay	tPLH, tPHL	4.5V	$C_L=50pF$	see Figure 5	-	-	48	ns
STCP to Qn propagation delay		4.5V	$C_L=50pF$	see Figure 6	-	-	48	ns
SHR to Q7S HIGH to LOW propagation delay	tPHL	4.5V	$C_L=50pF$	see Figure 9	-	-	45	ns
STR to Qn HIGH to LOW propagation delay		4.5V	$C_L=50pF$	see Figure 10	-	-	45	ns
Q7S transition time	tTHL, tTLH	4.5V	$C_L=50pF$	see Figure 5	-	-	22	ns
Qn transition time		4.5V	$C_L=50pF$		-	-	18	ns
SHCP(HIGH or LOW) pulse width	tw	4.5V	$C_L=50pF$	see Figure 5	24	-	-	ns
STCP(HIGH or LOW) pulse width		4.5V	$C_L=50pF$	see Figure 6	24	-	-	ns
SHR and STR (HIGH or LOW)		4.5V	$C_L=50pF$	see Figure 9 and Figure 10	24	-	-	ns
DS to SHCP Set up time	tsu	4.5V	$C_L=50pF$	see Figure 7	30	-	-	ns
SHR to STCP Set up time		4.5V	$C_L=50pF$	see Figure 8	30	-	-	ns
SHCP to STCP Set up time		4.5V	$C_L=50pF$	see Figure 6	30	-	-	ns
DS to SHCP hold time	th	4.5V	$C_L=50pF$	see Figure 7	7	-	-	ns
SHR to SHCP STR to STCP recovery time	trec	4.5V	$C_L=50pF$	see Figure 9 and Figure 10	15	-	-	ns
maximum frequency	fmax	4.5V	$C_L=15pF$	see Figure 5 and Figure 6	20	-	-	MHz



## 4、Testing Circuit

### 4.1、AC Testing Circuit

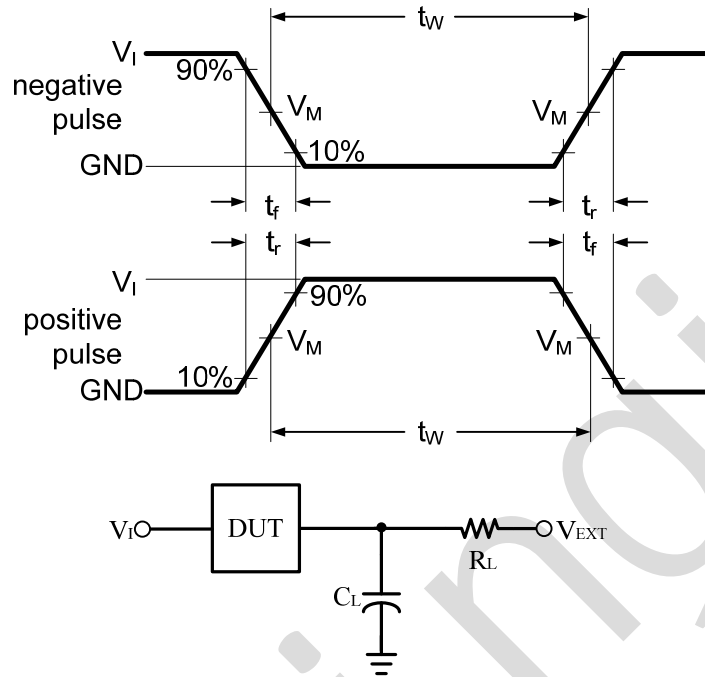

Figure 4. Test circuit for measuring switching times

$C_L$  includes probe and jig capacitance.

### 4.2、Test Data

Type	Input		Load		$V_{EXT}$		
	$V_I$	$t_r = t_f$	$C_L$	$R_L$	$t_{PLH}/t_{PHL}$	$t_{PLZ}/t_{PZL}$	$t_{PHZ}/t_{PZH}$
SN74HC594	$V_{CC}$	3.0ns	15pF, 50pF	1K $\Omega$	Open	$V_{CC}$	GND
SN74HCT594	3.0V	3.0ns	15pF, 50pF	1K $\Omega$	Open	$V_{CC}$	GND

### 4.3、AC Testing Waveforms

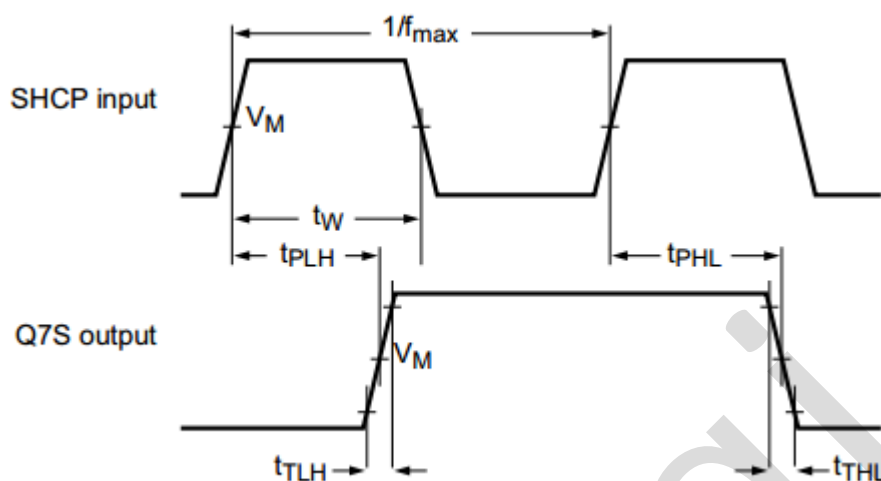

Figure 5. The shift clock (SHCP) to output (Q7S) propagation delays, the shift clock pulse width, the maximum shift clock frequency, and output transition times

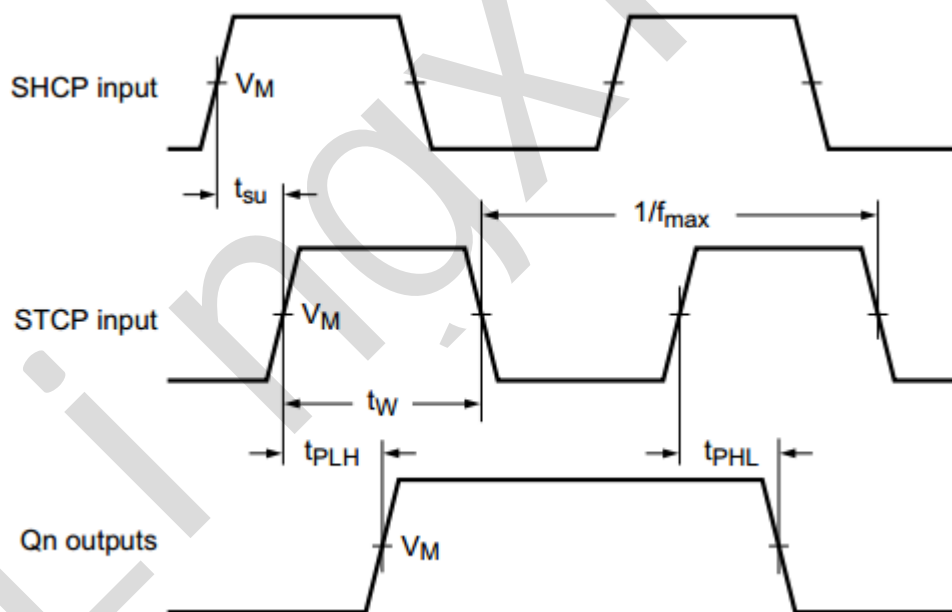

Figure 6. The storage clock (STCP) to output (Qn), propagation delays, the storage clock pulse width, the maximum storage clock pulse frequency and the shift clock to storage clock set-up time



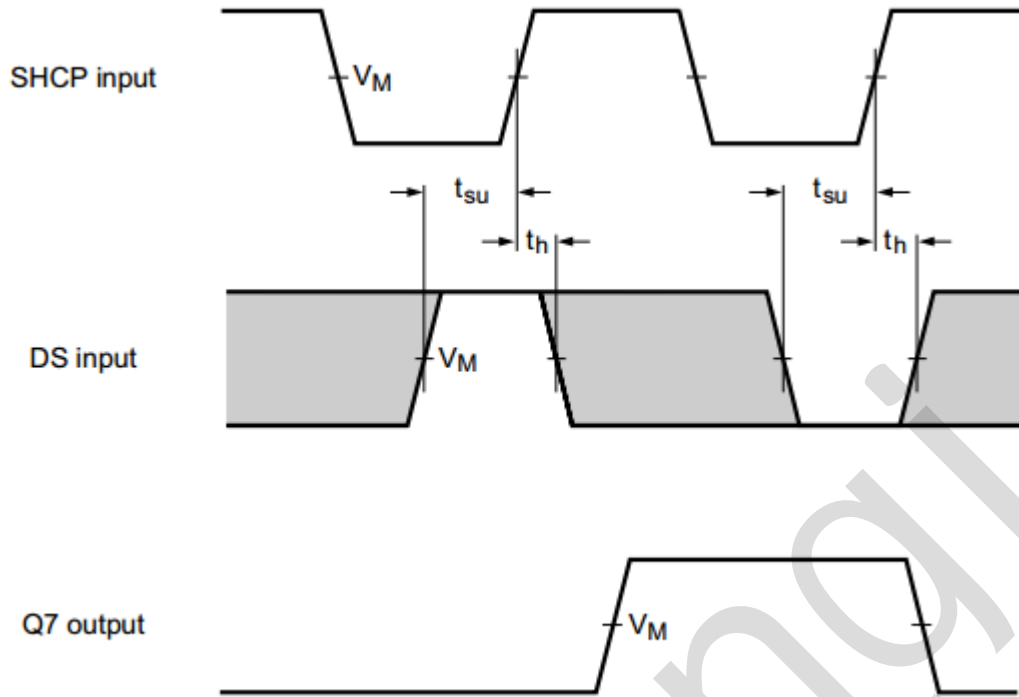

Figure 7. The data set-up time and hold times for DS input to SHCP

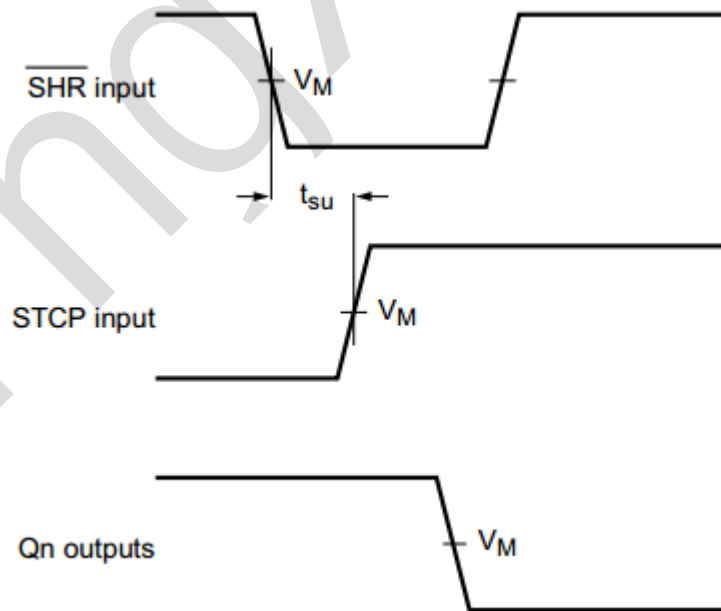

Figure 8 The set-up time shift reset ( $\overline{\text{SHR}}$ ) to storage clock (STCP)

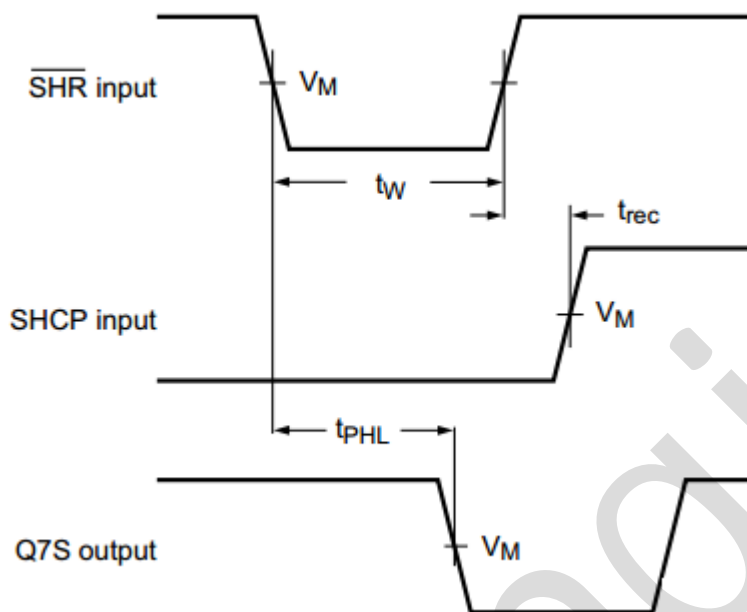

Figure 9 The shift reset ( $\overline{\text{SHR}}$ ) pulse width, the shift reset to output (Q7S) propagation delay and the shift reset to shift clock (SHCP) recovery time

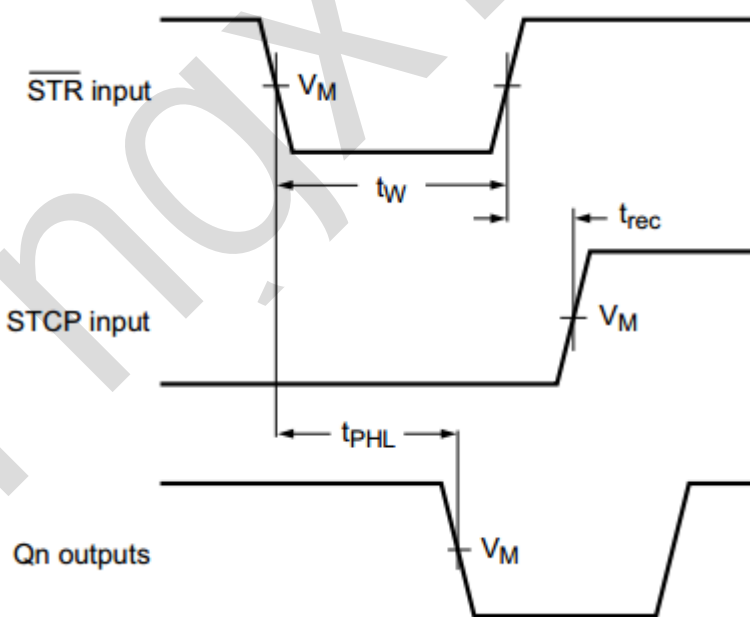

Figure 10 The storage reset ( $\overline{\text{STR}}$ ) pulse width, the storage reset to output (Qn) propagation delay and the storage reset to storage clock (STCP) recovery time



#### 4.4、Measurement Points

Type	Input	Output
	$V_M$	$V_M$
SN74HC594	$0.5 \times V_{CC}$	$0.5 \times V_{CC}$
SN74HCT594	1.3V	1.3V



灵星芯微 专注经营

## 5、Package Information

### 5.1、DIP16

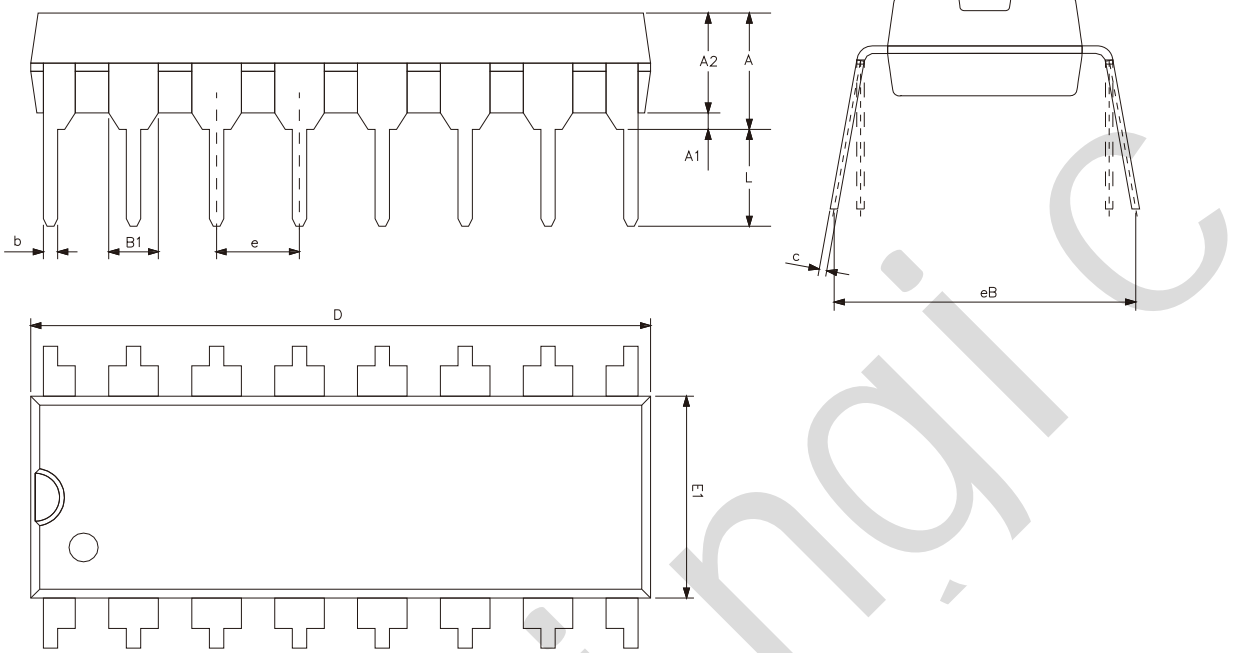

Symbol	Dimensions (mm)	
	Min.	Max.
A2	3.20	3.60
A1	0.51	-
A	3.60	5.33
L	3.00	3.60
b	0.36	0.56
B1	1.52	
D	18.80	19.94
E1	6.20	6.60
e	2.54	
c	0.20	0.36
eB	7.62	9.30



灵星芯微 精密制程

5.2、SOP16

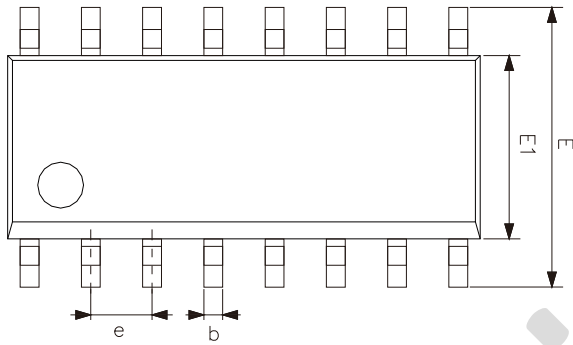
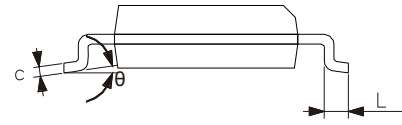
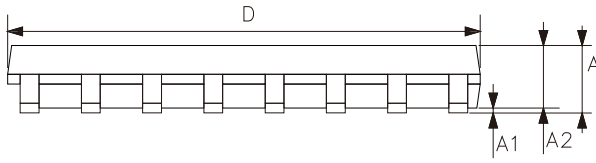

Symbol	Dimensions (mm)	
	Min.	Max.
A	1.35	1.80
A1	0.10	0.25
A2	1.25	1.55
b	0.33	0.51
c	0.19	0.25
D	9.50	10.10
E	5.80	6.30
E1	3.70	4.10
e	1.27	
L	0.35	0.89
$\theta$	0°	8°



灵星芯微 精密封装

5.3、TSSOP16

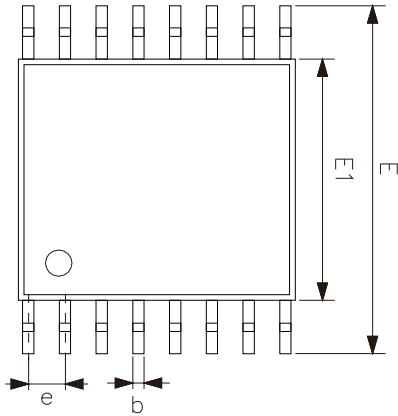
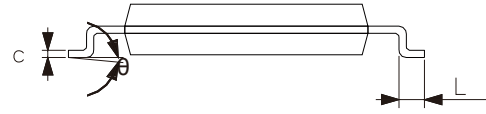
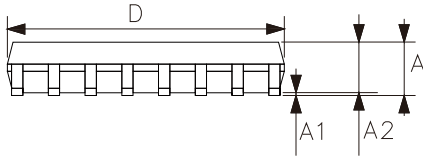

Symbol	Dimensions (mm)	
	Min.	Max.
A	-	1.20
A1	0.05	0.15
A2	0.80	1.05
b	0.19	0.30
c	0.09	0.20
D	4.90	5.10
E1	4.30	4.50
E	6.20	6.60
e	0.65	
L	0.45	0.75
$\theta$	0°	8°



## 6、Statements And Notes

### 6.1、The name and content of Hazardous substances or Elements in the product

Part name	Hazardous substances or Elements									
	Lead and lead compounds	Mercury and mercury compounds	Cadmium and cadmium compounds	Hexavalent chromium compounds	Polybrominated biphenyls	Polybrominated biphenyl ethers	Dibutyl phthalate	Butylbenzyl phthalate	Di-2-ethylhexyl phthalate	Diisobutyl phthalate
Lead frame	○	○	○	○	○	○	○	○	○	○
Plastic resin	○	○	○	○	○	○	○	○	○	○
Chip	○	○	○	○	○	○	○	○	○	○
The lead	○	○	○	○	○	○	○	○	○	○
Plastic sheet installed	○	○	○	○	○	○	○	○	○	○
explanation	○: Indicates that the content of hazardous substances or elements in the detection limit of the following SJ/T11363-2006 standard. ×: Indicates that the content of hazardous substances or elements exceeding the SJ/T11363-2006 Standard limit requirements.									

### 6.2、Notes

Recommended carefully reading this information before the use of this product;

The information in this document are subject to change without notice;

This information is using to the reference only, the company is not responsible for any loss;

The company is not responsible for the any infringement of the third party patents or other rights of the responsibility.

## X-ON Electronics

Largest Supplier of Electrical and Electronic Components

*Click to view similar products for [Counter Shift Registers](#) category:*

*Click to view products by [lingxingic](#) manufacturer:*

Other Similar products are found below :

[CD4031BE](#) [CD4034BE](#) [NLV74HC165ADTR2G](#) [5962-9172201M2A](#) [MC100EP142MNG](#) [MC100EP016AMNG](#) [MC74LV594ADR2G](#)  
[NLV14094BDTR2G](#) [NLV74HC589ADR2G](#) [AiP74HC595TA16.TR](#) [SN74LS295BN](#) [AIP74HC164TA14.TR](#) [TM74HC164](#) [74HC164D](#)  
[AiP74HC165SA16.TR](#) [74HC573D](#) [AiP74HC165TA16.TR](#) [XL74HC597-TS](#) [74HC164MT/TR](#) [XL74HC595TS](#) [74HC595DMT/TR](#)  
[CD4094DMT/TR](#) [74HC595D\(MS\)](#) [CD4094DM/TR](#) [74HC164D](#) [GN165D](#) [74HC595DM/TR](#) [AIP74HC595SA.TR](#) [XL4021B](#)  
[74HC164D\(MS\)](#) [74HC595MT/TR](#) [XL74HC165-TS](#) [74HC595D](#) [74HC595D](#) [74HC595D.](#) [74HCT595BQ](#) [RS595SXTSS16](#)  
[Aip74HC595SA16.TR](#) [SN74LS164DR-HXY](#) [74HC164DR](#) [RS595SXS16](#) [74HC165-HXY](#) [RS164XQ](#) [GN74HC595D](#) [74HC164DRG](#)  
[XD74HC165](#) [SN74LV165AQWBQBRQ1](#) [AiP74HC4094SA16.TR](#) [HX74HC595IDRG](#) [CD4094DN](#)