



SN74LS01 (LX)

Quad 2-Input Nand Gate with Open-Drain Outputs

Product Specification

Specification Revision History:

Version	Date	Description
2023-11-A0	2023-11	New
2024-02-A1	2024-02	Modify the parameters



Contents

1、 General Description.....	1
2、 Block Diagram And Pin Description	3
2.1、 Block Diagram	3
2.2、 Pin Configurations.....	3
2.3、 Pin Description.....	3
2.4、 Function Table.....	4
3、 Electrical Parameter	4
3.1、 Absolute Maximum Ratings.....	4
3.2、 Recommended Operating Conditions.....	4
3.3、 Electrical Characteristics.....	5
3.3.1、 DC Characteristics 1	5
3.3.2、 DC Characteristics 2	6
3.3.3、 AC Characteristics 1	7
3.3.4、 AC Characteristics 2	7
4、 Testing Circuit	8
4.1、 AC Testing Circuit	8
4.2、 Test Data	8
4.3、 AC Testing Waveforms.....	9
4.4、 Measurement Points.....	9
5、 Package Information	10
5.1、 DIP14	10
5.2、 SOP14	11
5.3、 TSSOP14.....	12
6、 Statements And Notes	13
6.1、 The name and content of Hazardous substances or Elements in the product.....	13
6.2、 Notes	13



1、General Description

The SN74LS01 contains four independent 2-input NAND Gates with open-drain outputs.

Features:

- Supply voltage range:
SN74LS01: 2V to 6V
- Input levels:
SN74LS01: CMOS level
- Temperature range: -40°C to +125°C
- Packaging information: DIP14/SOP14/TSSOP14

Ordering Information:

Tube packing specifications:

Part number	Packaging form	Marking code	Tube quantity	Boxed tube quantity	Boxed quantity	Notes
SN74LS01N (LX)	DIP14	SN74HC01N	25 PCS/tube	40 tube/box	1000 PCS/box	Dimensions of plastic enclosure: 19.0mm×6.4mm Pin spacing: 2.54mm
SN74LS01P (LX)	TSSOP14	74HC01	96 PCS/tube	200 tube/box	19200 PCS/box	Dimensions of plastic enclosure: 5.0mm×4.4mm Pin spacing: 0.65mm
SN74LS01D (LX)	SOP14	74HC01	50 PCS/tube	200 tube/box	10000 PCS/box	Dimensions of plastic enclosure: 8.7mm×3.9mm Pin spacing: 1.27mm

Reel packing specifications:

Part number	Packaging form	Marking code	Reel quantity	Boxed reel quantity	Notes
SN74LS01DR (LX)	SOP14	HC01	2500 PCS/reel	5000 PCS/box	Dimensions of plastic enclosure: 8.7mm×3.9mm Pin spacing: 1.27mm
SN74LS01PR (LX)	TSSOP14	74HC01	5000 PCS/reel	10000 PCS/box	Dimensions of plastic enclosure: 5.0mm×4.4mm Pin spacing: 0.65mm

Note: If the physical information is inconsistent with the ordering information, please refer to the actual product.



2、Block Diagram And Pin Description

2.1、Block Diagram

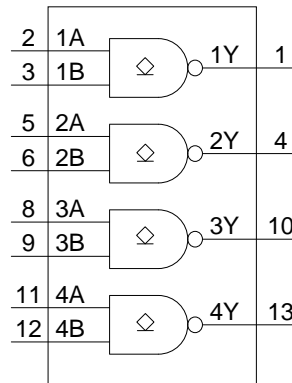

Figure 1. Logic symbol

2.2、Pin Configurations

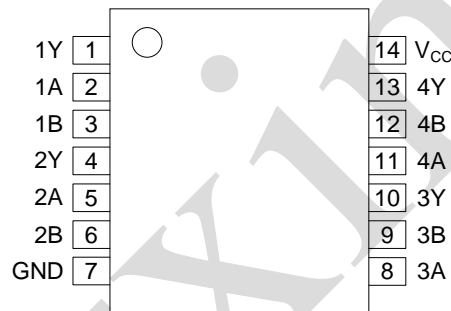

Figure 2. Pin Configurations

2.3、Pin Description

Pin No.	Pin Name	Description
1	1Y	data output
2	1A	data input
3	1B	data input
4	2Y	data output
5	2A	data input
6	2B	data input
7	GND	ground (0V)
8	3A	data input
9	3B	data input
10	3Y	data output
11	4A	data input
12	4B	data input
13	4Y	data output
14	V _{CC}	supply voltage



2.4、Function Table

Input		Output
nA	nB	nY
L	L	Z
L	H	Z
H	L	Z
H	H	L

Note: L=LOW voltage level; Z=high-impedance OFF-state.

3、Electrical Parameter

3.1、Absolute Maximum Ratings

(Voltages are referenced to GND (ground=0V), unless otherwise specified.)

Parameter	Symbol	Conditions	Min.	Max.	Unit	
supply voltage	V_{CC}	-	-0.5	+7	V	
supply current	I_{CC}	-	-	50	mA	
ground current	I_{GND}	-	-50	-	mA	
input clamping current	I_{IK}	$V_I < -0.5V$ or $V_I > V_{CC}+0.5V$	-	± 20	mA	
output clamping current	I_{OK}	$V_O < -0.5V$ or $V_O > V_{CC}+0.5V$	-	± 20	mA	
output current	I_O	$-0.5V < V_O < V_{CC}+0.5V$	-	± 25	mA	
storage temperature	T_{stg}	-	-65	+150	$^{\circ}C$	
soldering temperature	T_L	10s	DIP		245	$^{\circ}C$
			SOP/TSSOP		260	

3.2、Recommended Operating Conditions

Parameter	Symbol	Conditions	Min.	Typ.	Max.	Unit
SN74LS01						
supply voltage	V_{CC}	-	2.0	5.0	6.0	V
input voltage	V_I	-	0	-	V_{CC}	V
output voltage	V_O	-	0	-	V_{CC}	V
ambient temperature	T_{amb}	-	-40	-	+125	$^{\circ}C$



3.3、Electrical Characteristics

3.3.1、DC Characteristics 1

($T_{amb} = -40^{\circ}\text{C}$ to $+85^{\circ}\text{C}$, voltages are referenced to GND (ground=0V), unless otherwise specified.)

Parameter	Symbol	V _{CC}	Conditions	Min.	Typ.	Max.	Unit
SN74LS01							
HIGH-level input voltage	V _{IH}	2.0V	-	1.5	1.2	-	V
		4.5V	-	3.15	2.4	-	V
		6.0V	-	4.2	3.2	-	V
LOW-level input voltage	V _{IL}	2.0V	-	-	0.8	0.5	V
		4.5V	-	-	2.1	1.35	V
		6.0V	-	-	2.8	1.8	V
LOW-level output voltage	V _{OL}	2.0V	I _O =20uA	-	0	0.1	V
		4.5V	I _O =20uA	-	0	0.1	V
		6.0V	I _O =20uA	-	0	0.1	V
		4.5V	I _O =4.0mA	-	0.15	0.33	V
		6.0V	I _O =5.2mA	-	0.16	0.33	V
input leakage current	I _I	6.0V	V _I =V _{CC} or GND	-	-	±1	uA
OFF-state output current	I _{OZ}	6.0V	V _I =V _{IH} or V _{IL} ; V _O =V _{CC} or GND	-	-	±5	uA
supply current	I _{CC}	6.0V	V _I =V _{CC} or GND; I _O =0A	-	-	10	uA



3.3.2、DC Characteristics 2

($T_{amb} = -40^{\circ}\text{C}$ to $+125^{\circ}\text{C}$, voltages are referenced to GND (ground=0V), unless otherwise specified.)

Parameter	Symbol	V _{CC}	Conditions	Min.	Typ.	Max.	Unit
SN74LS01							
HIGH-level input voltage	V _{IH}	2.0V	-	1.5	-	-	V
		4.5V	-	3.15	-	-	V
		6.0V	-	4.2	-	-	V
LOW-level input voltage	V _{IL}	2.0V	-	-	-	0.5	V
		4.5V	-	-	-	1.35	V
		6.0V	-	-	-	1.8	V
LOW-level output voltage	V _{OL}	2.0V	I _O =20uA	-	-	0.1	V
		4.5V	I _O =20uA	-	-	0.1	V
		6.0V	I _O =20uA	-	-	0.1	V
		4.5V	I _O =4.0mA	-	-	0.4	V
		6.0V	I _O =5.2mA	-	-	0.4	V
input leakage current	I _I	6.0V	V _I =V _{CC} or GND	-	-	±1	uA
OFF-state output current	I _{OZ}	6.0V	V _I =V _{IH} or V _{IL} ; V _O =V _{CC} or GND	-	-	±10	uA
supply current	I _{CC}	6.0V	V _I =V _{CC} or GND; I _O =0A	-	-	160	uA



3.3.3、AC Characteristics 1

($T_{amb} = -40^{\circ}\text{C}$ to $+85^{\circ}\text{C}$, voltages are referenced to GND (ground=0V), unless otherwise specified.)

Parameter	Symbol	V_{CC}	Conditions	Min.	Typ.	Max.	Unit	
SN74LS01								
propagation delay	t_{PLZ}, t_{PZL}	2.0V	$C_L = 50\text{pF}$	see Figure 4	-	41	155	ns
		4.5V	$C_L = 50\text{pF}$		-	15	23	ns
		5.0V	$C_L = 15\text{pF}$		-	12	-	ns
		6.0V	$C_L = 50\text{pF}$		-	12	20	ns
transition time	t_{THL}	2.0V	$C_L = 50\text{pF}$	see Figure 4	-	19	95	ns
		4.5V	$C_L = 50\text{pF}$		-	7	19	ns
		6.0V	$C_L = 50\text{pF}$		-	6	16	ns

3.3.4、AC Characteristics 2

($T_{amb} = -40^{\circ}\text{C}$ to $+125^{\circ}\text{C}$, voltages are referenced to GND (ground=0V), unless otherwise specified.)

Parameter	Symbol	V_{CC}	Conditions	Min.	Typ.	Max.	Unit	
SN74LS01								
propagation delay	t_{PLZ}, t_{PZL}	2.0V	$C_L = 50\text{pF}$	see Figure 4	-	-	190	ns
		4.5V	$C_L = 50\text{pF}$		-	-	38	ns
		6.0V	$C_L = 50\text{pF}$		-	-	32	ns
transition time	t_{THL}	2.0V	$C_L = 50\text{pF}$	see Figure 4	-	-	110	ns
		4.5V	$C_L = 50\text{pF}$		-	-	22	ns
		6.0V	$C_L = 50\text{pF}$		-	-	19	ns

4、Testing Circuit

4.1、AC Testing Circuit

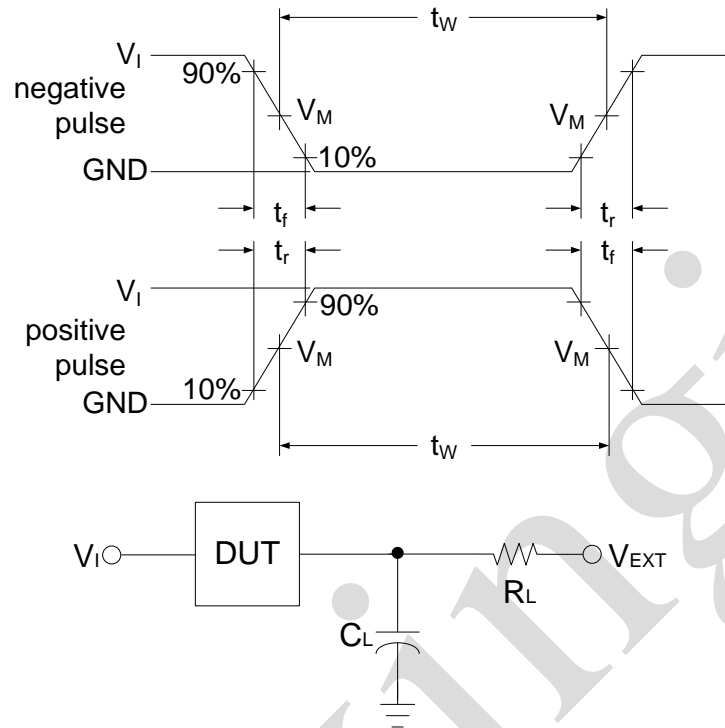

Figure 3. Test circuit for measuring switching times

C_L includes probe and jig capacitance.

4.2、Test Data

Type	Input		Load		V_{EXT}		
	V_I	$t_r = t_f$	C_L	R_L	t_{PLH}/t_{PHL}	t_{PLZ}/t_{PZL}	t_{PHZ}/t_{PZH}
SN74LS01	V_{CC}	3.0ns	15pF, 50pF	1K Ω	Open	V_{CC}	GND



4.3、AC Testing Waveforms

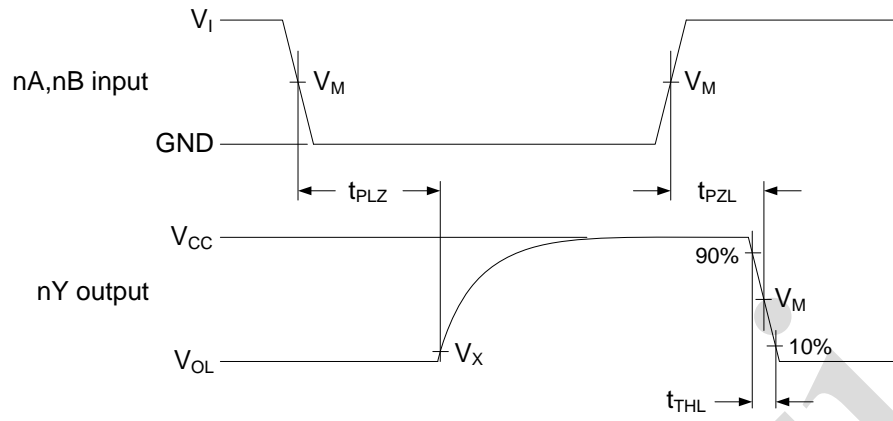

Figure 4. Input to output propagation delays

4.4、Measurement Points

Type	Input	Output	
	V_M	V_M	V_X
SN74LS01	$0.5 \times V_{CC}$	$0.5 \times V_{CC}$	$0.1 \times V_{CC}$



5、Package Information

5.1、DIP14

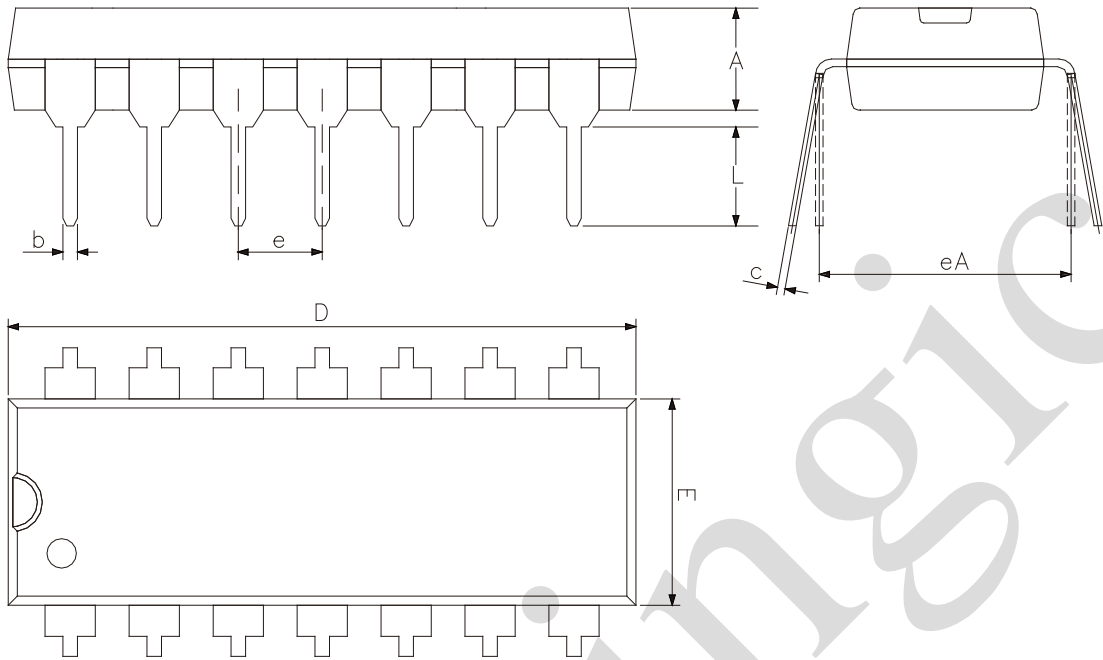

2023/12/A	Dimensions In Millimeters	
Symbol	Min	Max
A	3.05	3.60
b	0.33	0.56
c	0.20	0.36
D	18.80	19.40
E	6.20	6.60
e	2.54	
eA	7.62	10.90
L	2.92	—



5.2、SOP14

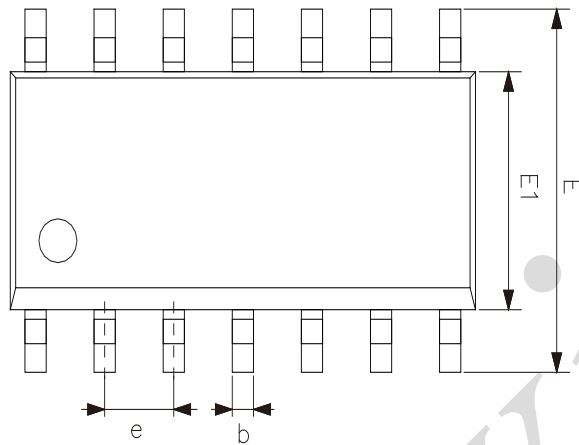
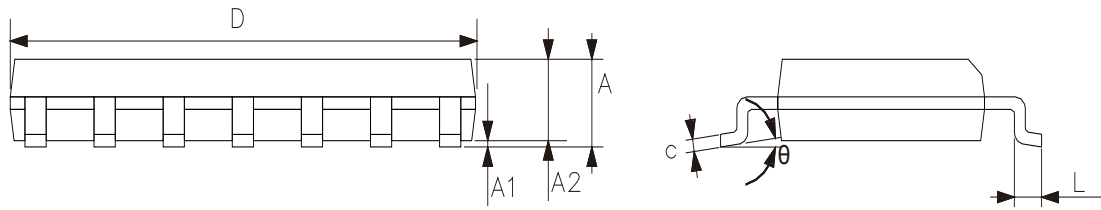

2023/12/A	Dimensions In Millimeters	
Symbol	Min.	Max.
A	1.50	1.75
A1	0.05	0.25
A2	1.30	—
b	0.33	0.50
c	0.19	0.25
D	8.43	8.76
E	5.80	6.25
E1	3.75	4.00
e	1.27	
L	0.40	0.89
θ	0°	8°



5.3、TSSOP14

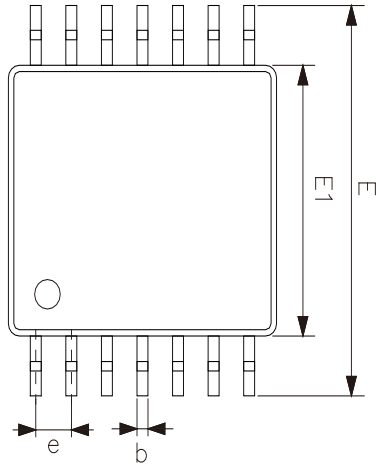
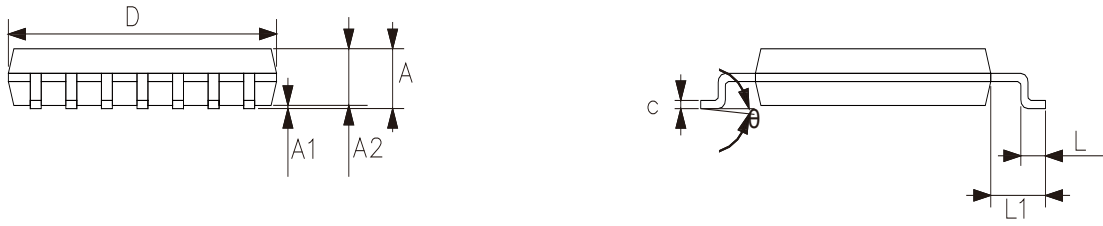

2023/12/A	Dimensions In Millimeters	
Symbol	Min	Max
A	—	1.20
A1	0.05	0.15
A2	0.80	1.05
b	0.19	0.30
c	0.09	0.20
D	4.90	5.10
E1	4.30	4.50
E	6.20	6.60
e	0.65	
L	0.45	0.75
L1	1.00	
θ	0°	8°



6、 Statements And Notes

6.1、 The name and content of Hazardous substances or Elements in the product

Part name	Hazardous substances or Elements									
	Lead and lead compounds	Mercury and mercury compounds	Cadmium and cadmium compounds	Hexavalent chromium compounds	Polybrominated biphenyls	Polybrominated biphenyl ethers	Dibutyl phthalate	Butylbenzyl phthalate	Di-2-ethylhexyl phthalate	Diisobutyl phthalate
Lead frame	○	○	○	○	○	○	○	○	○	○
Plastic resin	○	○	○	○	○	○	○	○	○	○
Chip	○	○	○	○	○	○	○	○	○	○
The lead	○	○	○	○	○	○	○	○	○	○
Plastic sheet installed	○	○	○	○	○	○	○	○	○	○
explanation	<p>○: Indicates that the content of hazardous substances or elements in the detection limit of the following the SJ/T11363-2006 standard.</p> <p>×: Indicates that the content of hazardous substances or elements exceeding the SJ/T11363-2006 Standard limit requirements.</p>									

6.2、 Notes

We recommend you to read this chapter carefully before using this product.

The information in this chapter is provided for reference only and Lingxing disclaims any express or implied warranties, including but not limited to applicability, special application or non-infringement of third party rights.

This product is not suitable for critical equipment such as life-saving, life-sustaining or safety equipment. It is also not suitable for applications that may result in personal injury, death, or serious property or environmental damage due to product malfunction or failure. Lingxing will not be liable for any damages incurred by the customers at their own risk for such applications.

The customer is responsible for conducting all necessary tests Lingxing's application to avoid failure in the application or the application of the customer's third party users. Lingxing does not accept any liability. The Company reserves the right to change or improve the information published in this chapter at any time. The information in this chapter are subject to change without notice. We recommend the customer to consult our sales staff before purchasing.

Please obtain related materials form Lingxing's regular channels and we are not responsible for its content if it is provided by sources other than our company.

In case of any conflict between the Chinese and English version, the version is subject to the Chinese one.

X-ON Electronics

Largest Supplier of Electrical and Electronic Components

Click to view similar products for [Logic Gates](#) category:

Click to view products by [lingxingic](#) manufacturer:

Other Similar products are found below :

[74HC85N](#) [NL17SG32DFT2G](#) [CD4068BE](#) [NL17SG86DFT2G](#) [NLX1G11AMUTCG](#) [NLX1G97MUTCG](#) [74LS38](#) [74LVC1G08Z-7](#)
[CD4025BE](#) [NLV17SZ00DFT2G](#) [NLV17SZ126DFT2G](#) [NLV27WZ17DFT2G](#) [NLV74HC02ADR2G](#) [74HC32S14-13](#) [74LS133](#)
[74LVC1G32Z-7](#) [74LVC1G86Z-7](#) [NLV74HC14ADR2G](#) [NLV74HC20ADR2G](#) [NLVVHC1G09DFT1G](#) [NLX2G86MUTCG](#)
[74LVC2G32RA3-7](#) [74LVC2G00HD4-7](#) [NL17SG02P5T5G](#) [74LVC2G86HK3-7](#) [NLVVHC1G14DFT2G](#) [NLX1G99DMUTWG](#)
[NLVVHC1G00DFT2G](#) [NLV7SZ57DFT2G](#) [NLV74VHC04DTR2G](#) [NLV27WZ00USG](#) [NLU1G86CMUTCG](#) [NLU1G08CMUTCG](#)
[NL17SZ32P5T5G](#) [NL17SZ00P5T5G](#) [NL17SH02P5T5G](#) [74AUP2G00RA3-7](#) [NLVVHC1GT00DFT2G](#) [NLV74HC02ADTR2G](#)
[NLX1G332CMUTCG](#) [NLVHCT132ADTR2G](#) [NL17SG86P5T5G](#) [NL17SZ05P5T5G](#) [NLV74VHC00DTR2G](#) [NLVVHC1G02DFT1G](#)
[NLV74HC86ADR2G](#) [74LVC2G32HK3-7](#) [74LVC2G86RA3-7](#) [NL17SZ38DBVT1G](#) [NLV18SZ00DFT2G](#)