



SN74LS147 (LX) 10-to-4 Line Priority Encoder

Product Specification

Specification Revision History:

Version	Date	Description
2021-06-A1	2021-06	New
2021-11-A2	2021-11	Modify Ordering Information; Modify ambient temperature to -40°C~+105°C and add electrical characteristics of -40°C~+105°C
2021-12-A3	2021-12	Modify Ordering Information
2023-11-A4	2023-11	Modify ambient temperature to -40 °C ~+125 °C and modify Ordering Information



1、General Description

The SN74LS147 9-input priority encoders accept data from nine active LOW inputs ($\bar{A}0$ to $\bar{A}8$) and provide a binary representation on the four active LOW outputs ($\bar{Y}0$ to $\bar{Y}3$). A priority is assigned to each input so that when two or more inputs are simultaneously active, the input with the highest priority is represented on the output, with input line $\bar{A}8$ having the highest priority.

The devices provide the 10-line to 4-line priority encoding function by use of the implied decimal “zero”. The “zero” is encoded when all nine data inputs are HIGH, forcing all four outputs HIGH.

Features:

- Encodes 10-line decimal to 4-line BCD
- Useful for 10-position switch encoding
- Used in code converters and generators
- Specified from -40°C to +125°C
- Packaging information: DIP16/SOP16/TSSOP16



灵星芯微 集成电路

Ordering Information:

Tube packing specifications:

Part number	Packaging form	Marking code	Tube quantity	Boxed tube quantity	Boxed quantity	Notes
SN74LS147N(LX)	DIP16	SN74LS147N	25 PCS/tube	40 tube/box	1000 PCS/box	Dimensions of plastic enclosure: 19.0mm×6.4mm Pin spacing: 2.54mm
SN74LS147DR(LX)	SOP16	LS147	50 PCS/tube	200 tube/box	10000 PCS/box	Dimensions of plastic enclosure: 10.0mm×3.9mm Pin spacing: 1.27mm
SN74LS147PW(LX)	TSSOP16	LS147	96 PCS/tube	200 tube/box	19200 PCS/box	Dimensions of plastic enclosure: 5.0mm×4.4mm Pin spacing: 0.65mm



Reel packing specifications:

Part number	Packaging form	Marking code	Reel quantity	Boxed reel quantity	Notes
SN74LS147DR(LX)	SOP16	LS147	2500 PCS/reel	5000 PCS/box	Dimensions of plastic enclosure: 10.0mm×3.9mm Pin spacing:1.27mm
SN74LS147PW(LX)	TSSOP16	LS147	5000 PCS/reel	10000 PCS/box	Dimensions of plastic enclosure: 5.0mm×4.4mm Pin spacing:0.65mm

Note: If the physical information is inconsistent with the ordering information, please refer to the actual product.



2、Block Diagram And Pin Description

2.1、Block Diagram

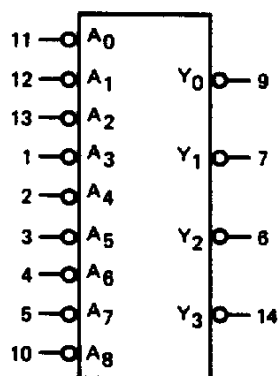

Figure 1. Logic symbol

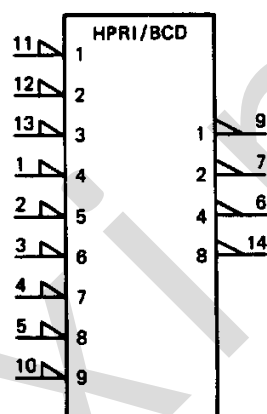

Figure 2. IEC logic symbol

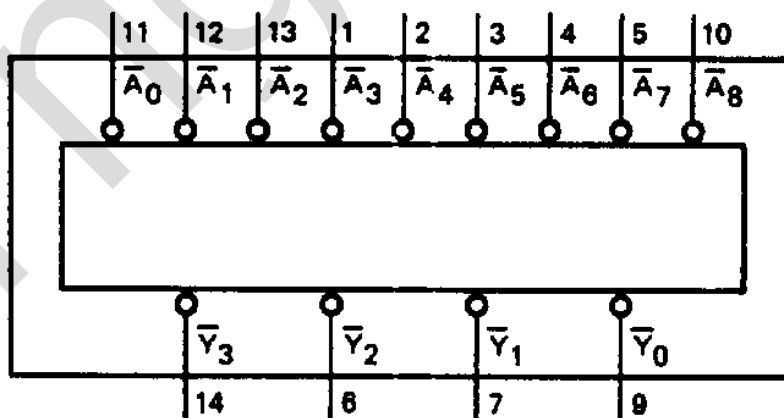

Figure 3. Functional diagram

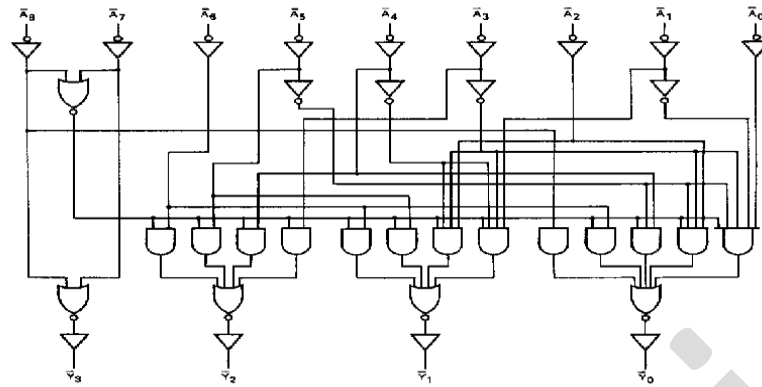
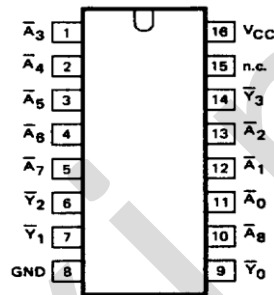

Figure 4. Logic diagram

2.2、Pin Configurations



2.3、Pin Description

Pin No.	Pin Name	Description
1	$\bar{A}3$	decimal data input (active LOW)
2	$\bar{A}4$	decimal data input (active LOW)
3	$\bar{A}5$	decimal data input (active LOW)
4	$\bar{A}6$	decimal data input (active LOW)
5	$\bar{A}7$	decimal data input (active LOW)
6	$\bar{Y}2$	BCD address output (active LOW)
7	$\bar{Y}1$	BCD address output (active LOW)
8	GND	ground (0V)
9	$\bar{Y}0$	BCD address output (active LOW)
10	$\bar{A}8$	decimal data input (active LOW)
11	$\bar{A}0$	decimal data input (active LOW)
12	$\bar{A}1$	decimal data input (active LOW)
13	$\bar{A}2$	decimal data input (active LOW)
14	$\bar{Y}3$	BCD address output (active LOW)
15	n.c.	not connected
16	V_{CC}	supply voltage



2.4、Function Table

Input									Output			
A0	A1	A2	A3	A4	A5	A6	A7	A8	Y3	Y2	Y1	Y0
H	H	H	H	H	H	H	H	H	H	H	H	H
X	X	X	X	X	X	X	X	L	L	H	H	L
X	X	X	X	X	X	X	L	H	L	H	H	H
X	X	X	X	X	X	L	H	H	H	L	L	L
X	X	X	X	X	L	H	H	H	H	L	L	H
X	X	X	X	L	H	H	H	H	H	L	H	L
X	X	X	L	H	H	H	H	H	H	L	H	H
X	X	L	H	H	H	H	H	H	H	H	L	L
X	L	H	H	H	H	H	H	H	H	H	L	H
L	H	H	H	H	H	H	H	H	H	H	H	L

Note: H=HIGH voltage level; L=LOW voltage level; X = don't care.

3、Electrical Parameter

3.1、Absolute Maximum Ratings

(Voltages are referenced to GND (ground=0V), unless otherwise specified.)

Parameter	Symbol	Conditions	Min.	Max.	Unit
supply voltage	V_{CC}	-	-0.5	+7.0	V
input clamping current	I_{IK}	$V_I < -0.5V$ or $V_I > V_{CC}+0.5V$	-	± 20	mA
output clamping current	I_{OK}	$V_O < -0.5V$ or $V_O > V_{CC}+0.5V$	-	± 20	mA
output current	I_O	$-0.5V < V_O < V_{CC}+0.5V$	-	± 25	mA
supply current	I_{CC}	-	-	+50	mA
ground current	I_{GND}	-	-50	-	mA
storage temperature	T_{stg}	-	-65	+150	°C
total power dissipation	P_{tot}	-	-	500	mW
soldering temperature	T_L	10s	DIP	245	°C
			SOP/TSSOP	260	

Note:

[1] For DIP16 packages: above 70°C the value of P_{tot} derates linearly with 12mW/K.

[2] For SOP16 packages: above 70°C the value of P_{tot} derates linearly with 8mW/K.

[3] For (T)SSOP16 packages: above 60°C the value of P_{tot} derates linearly with 5.5mW/K.



3.2、Recommended Operating Conditions

Parameter	Symbol	Conditions	Min.	Typ.	Max.	Unit
supply voltage	V_{CC}	-	2.0	5.0	6.0	V
input voltage	V_I	-	0	-	V_{CC}	V
output voltage	V_O	-	0	-	V_{CC}	V
input transition rise and fall rate	$\Delta t/\Delta V$	$V_{CC}=2.0V$	-	-	625	ns/V
		$V_{CC}=4.5V$	-	1.67	139	ns/V
		$V_{CC}=6.0V$	-	-	83	ns/V
ambient temperature	T_{amb}	-	-40	-	+125	°C

3.3、Electrical Characteristics

3.3.1、DC Characteristics 1

($T_{amb}=25^{\circ}C$, voltages are referenced to GND (ground=0V), unless otherwise specified.)

Parameter	Symbol	Conditions	Min.	Typ.	Max.	Unit	
HIGH-level input voltage	V_{IH}	$V_{CC}=2.0V$	1.5	1.2	-	V	
		$V_{CC}=4.5V$	3.15	2.4	-	V	
		$V_{CC}=6.0V$	4.2	3.2	-	V	
LOW-level input voltage	V_{IL}	$V_{CC}=2.0V$	-	0.8	0.5	V	
		$V_{CC}=4.5V$	-	2.1	1.35	V	
		$V_{CC}=6.0V$	-	2.8	1.8	V	
HIGH-level output voltage	V_{OH}	$V_I=V_{IH}$ or V_{IL}	$I_O=-20\mu A$; $V_{CC}=2.0V$	1.9	2.0	-	V
			$I_O=-20\mu A$; $V_{CC}=4.5V$	4.4	4.5	-	V
			$I_O=-20\mu A$; $V_{CC}=6.0V$	5.9	6.0	-	V
			$I_O=-4.0mA$; $V_{CC}=4.5V$	3.98	4.32	-	V
			$I_O=-5.2mA$; $V_{CC}=6.0V$	5.48	5.81	-	V
LOW-level output voltage	V_{OL}	$V_I=V_{IH}$ or V_{IL}	$I_O=20\mu A$; $V_{CC}=2.0V$	-	0	0.1	V
			$I_O=20\mu A$; $V_{CC}=4.5V$	-	0	0.1	V
			$I_O=20\mu A$; $V_{CC}=6.0V$	-	0	0.1	V
			$I_O=4.0mA$; $V_{CC}=4.5V$	-	0.15	0.26	V
			$I_O=5.2mA$; $V_{CC}=6.0V$	-	0.16	0.26	V
input leakage current	I_I	$V_I=V_{CC}$ or GND; $V_{CC}=6.0V$	-	-	± 1.0	μA	
supply current	I_{CC}	$V_I=V_{CC}$ or GND; $I_O=0A$; $V_{CC}=6.0V$	-	-	8.0	μA	
input capacitance	C_I	-	-	3.5	-	pF	



3.3.2、DC Characteristics 2

($T_{amb}=-40^{\circ}\text{C}$ to $+85^{\circ}\text{C}$, voltages are referenced to GND (ground=0V), unless otherwise specified.)

Parameter	Symbol	Conditions	Min.	Typ.	Max.	Unit	
HIGH-level input voltage	V_{IH}	$V_{CC}=2.0V$	1.5	-	-	V	
		$V_{CC}=4.5V$	3.15	-	-	V	
		$V_{CC}=6.0V$	4.2	-	-	V	
LOW-level input voltage	V_{IL}	$V_{CC}=2.0V$	-	-	0.5	V	
		$V_{CC}=4.5V$	-	-	1.35	V	
		$V_{CC}=6.0V$	-	-	1.8	V	
HIGH-level output voltage	V_{OH}	$V_I=V_{IH}$ or V_{IL}	$I_O=-20\mu A; V_{CC}=2.0V$	1.9	-	-	V
			$I_O=-20\mu A; V_{CC}=4.5V$	4.4	-	-	V
			$I_O=-20\mu A; V_{CC}=6.0V$	5.9	-	-	V
			$I_O=-4.0mA; V_{CC}=4.5V$	3.84	-	-	V
			$I_O=-5.2mA; V_{CC}=6.0V$	5.34	-	-	V
LOW-level output voltage	V_{OL}	$V_I=V_{IH}$ or V_{IL}	$I_O=20\mu A; V_{CC}=2.0V$	-	-	0.1	V
			$I_O=20\mu A; V_{CC}=4.5V$	-	-	0.1	V
			$I_O=20\mu A; V_{CC}=6.0V$	-	-	0.1	V
			$I_O=4.0mA; V_{CC}=4.5V$	-	-	0.33	V
			$I_O=5.2mA; V_{CC}=6.0V$	-	-	0.33	V
input leakage current	I_I	$V_I=V_{CC}$ or GND; $V_{CC}=6.0V$	-	-	± 1.0	μA	
supply current	I_{CC}	$V_I=V_{CC}$ or GND; $I_O=0A; V_{CC}=6.0V$	-	-	80	μA	



3.3.3、DC Characteristics 3

($T_{amb}=-40^{\circ}\text{C}$ to $+125^{\circ}\text{C}$, voltages are referenced to GND (ground=0V), unless otherwise specified.)

Parameter	Symbol	Conditions	Min.	Typ.	Max.	Unit	
HIGH-level input voltage	V_{IH}	$V_{CC}=2.0\text{V}$	1.5	-	-	V	
		$V_{CC}=4.5\text{V}$	3.15	-	-	V	
		$V_{CC}=6.0\text{V}$	4.2	-	-	V	
LOW-level input voltage	V_{IL}	$V_{CC}=2.0\text{V}$	-	-	0.5	V	
		$V_{CC}=4.5\text{V}$	-	-	1.35	V	
		$V_{CC}=6.0\text{V}$	-	-	1.8	V	
HIGH-level output voltage	V_{OH}	$V_I=V_{IH}$ or V_{IL}	$I_O=-20\mu\text{A}; V_{CC}=2.0\text{V}$	1.9	-	-	V
			$I_O=-20\mu\text{A}; V_{CC}=4.5\text{V}$	4.4	-	-	V
			$I_O=-20\mu\text{A}; V_{CC}=6.0\text{V}$	5.9	-	-	V
			$I_O=-4.0\text{mA}; V_{CC}=4.5\text{V}$	3.7	-	-	V
			$I_O=-5.2\text{mA}; V_{CC}=6.0\text{V}$	5.2	-	-	V
LOW-level output voltage	V_{OL}	$V_I=V_{IH}$ or V_{IL}	$I_O=20\mu\text{A}; V_{CC}=2.0\text{V}$	-	-	0.1	V
			$I_O=20\mu\text{A}; V_{CC}=4.5\text{V}$	-	-	0.1	V
			$I_O=20\mu\text{A}; V_{CC}=6.0\text{V}$	-	-	0.1	V
			$I_O=4.0\text{mA}; V_{CC}=4.5\text{V}$	-	-	0.4	V
			$I_O=5.2\text{mA}; V_{CC}=6.0\text{V}$	-	-	0.4	V
input leakage current	I_I	$V_I=V_{CC}$ or GND; $V_{CC}=6.0\text{V}$	-	-	± 1.0	μA	
supply current	I_{CC}	$V_I=V_{CC}$ or GND; $I_O=0\text{A}; V_{CC}=6.0\text{V}$	-	-	160	μA	



3.3.4、AC Characteristics 1

($T_{amb}=25^{\circ}C$, $GND=0V$, $t_r=t_f=6ns$, $C_L=50pF$, unless otherwise specified.)

Parameter	Symbol	Conditions	Min.	Typ.	Max.	Unit	
$\bar{A}n$ to $\bar{Y}n$ propagation delay	t_{pd}	see Figure 6 ^[1]	$V_{CC}=2.0V$	-	50	160	ns
			$V_{CC}=4.5V$	-	18	32	ns
			$V_{CC}=5.0V$; $C_L=15pF$	-	15	-	ns
			$V_{CC}=6.0V$	-	14	27	ns
transition time	t_t	see Figure 6 ^[2]	$V_{CC}=2.0V$	-	19	75	ns
			$V_{CC}=4.5V$	-	7	15	ns
			$V_{CC}=6.0V$	-	6	6	ns
power dissipation capacitance	C_{PD}	$V_I=GND$ to V_{CC} ^[3]	-	30	-	pF	

Note:

[1] t_{pd} is the same as t_{PLH} and t_{PHL} .

[2] t_t is the same as t_{THL} and t_{TLH} .

[3] C_{PD} is used to determine the dynamic power dissipation (P_D in μW).

$P_D=C_{PD}\times V_{CC}^2\times f_i+\sum(C_L\times V_{CC}^2\times f_o)$ where:

f_i =input frequency in MHz;

f_o =output frequency in MHz;

C_L =output load capacitance in pF;

V_{CC} =supply voltage in V;

$\sum(C_L\times V_{CC}^2\times f_o)$ =sum of outputs.



3.3.5、AC Characteristics 2

($T_{amb}=-40^{\circ}\text{C}$ to $+85^{\circ}\text{C}$, $\text{GND}=0\text{V}$, $t_r=t_f=6\text{ns}$, $C_L=50\text{pF}$, unless otherwise specified.)

Parameter	Symbol	Conditions	Min.	Typ.	Max.	Unit	
\bar{A}_n to \bar{Y}_n propagation delay	t_{pd}	see Figure 6 ^[1]	$V_{CC}=2.0\text{V}$	-	-	200	ns
			$V_{CC}=4.5\text{V}$	-	-	40	ns
			$V_{CC}=6.0\text{V}$	-	-	34	ns
transition time	t_t	see Figure 6 ^[2]	$V_{CC}=2.0\text{V}$	-	-	95	ns
			$V_{CC}=4.5\text{V}$	-	-	19	ns
			$V_{CC}=6.0\text{V}$	-	-	16	ns

Note:

[1] t_{pd} is the same as t_{PLH} and t_{PHL} .

[2] t_t is the same as t_{THL} and t_{TLH} .

3.3.6、AC Characteristics 3

($T_{amb}=-40^{\circ}\text{C}$ to $+125^{\circ}\text{C}$, $\text{GND}=0\text{V}$, $t_r=t_f=6\text{ns}$, $C_L=50\text{pF}$, unless otherwise specified.)

Parameter	Symbol	Conditions	Min.	Typ.	Max.	Unit	
\bar{A}_n to \bar{Y}_n propagation delay	t_{pd}	see Figure 6 ^[1]	$V_{CC}=2.0\text{V}$	-	-	240	ns
			$V_{CC}=4.5\text{V}$	-	-	48	ns
			$V_{CC}=6.0\text{V}$	-	-	41	ns
transition time	t_t	see Figure 6 ^[2]	$V_{CC}=2.0\text{V}$	-	-	110	ns
			$V_{CC}=4.5\text{V}$	-	-	22	ns
			$V_{CC}=6.0\text{V}$	-	-	19	ns

Note:

[1] t_{pd} is the same as t_{PLH} and t_{PHL} .

[2] t_t is the same as t_{THL} and t_{TLH} .



4、Testing Circuit

4.1、AC Testing Circuit

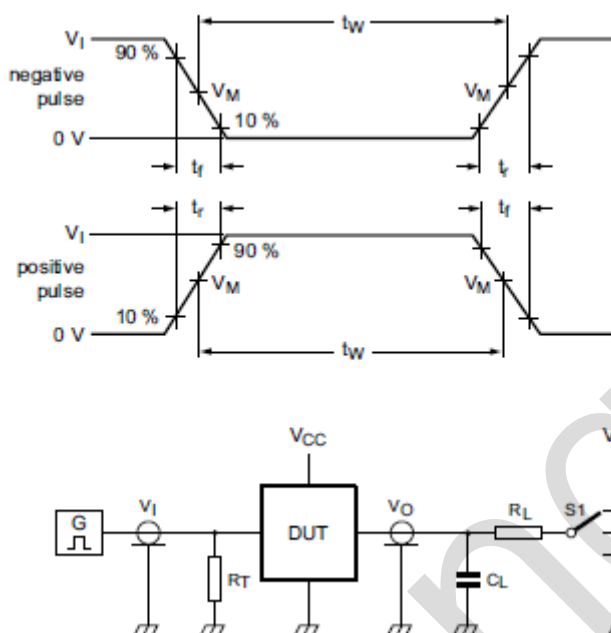

Figure 5. Test circuit for measuring switching times

Definitions for test circuit:

C_L =Load capacitance including jig and probe capacitance.

R_T =Termination resistance should be equal to the output impedance Z_o of the pulse generator.

R_L =Load resistance.

$S1$ =Test selection switch

4.2、AC Testing Waveforms

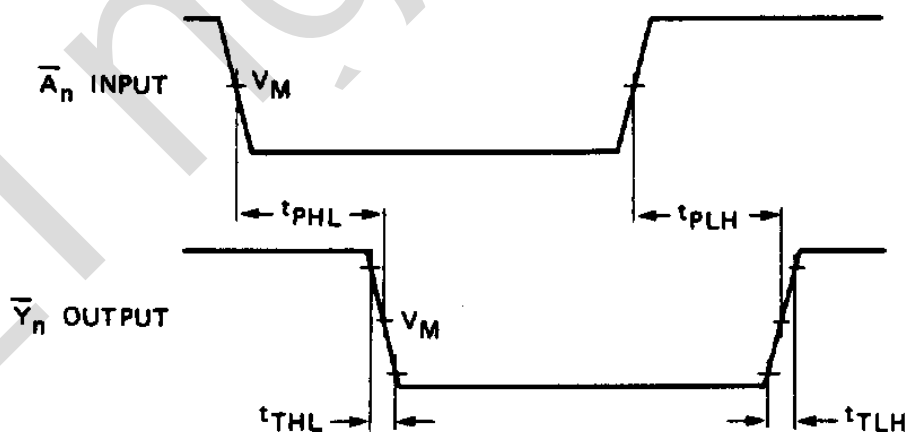

Figure 6. Input (\bar{A}_n) to output (\bar{Y}_n) propagation delays and output transition times



4.3、Measurement Points

Input	Output		
V_M	V_M	V_X	V_Y
$0.5 \times V_{CC}$	$0.5 \times V_{CC}$	$0.1 \times V_{CC}$	$0.9 \times V_{CC}$

4.4、Test Data

Input		Load		S1 position
V_I	t_r, t_f	C_L	R_L	t_{PLH}, t_{PHL}
V_{CC}	6ns	15pF, 50pF	1k Ω	open



5、Package Information

5.1、DIP16

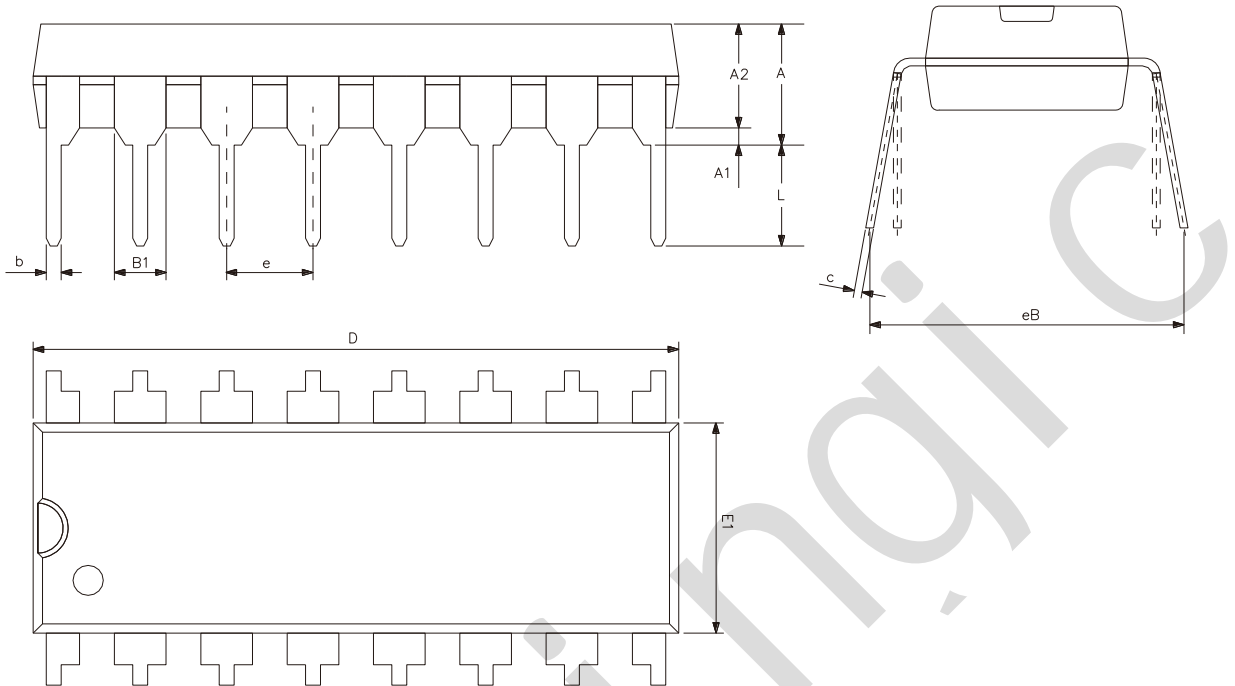

Symbol	Dimensions (mm)	
	Min.	Max.
A2	3.20	3.60
A1	0.51	-
A	3.60	5.33
L	3.00	3.60
b	0.36	0.56
B1	1.52	
D	18.80	19.94
E1	6.20	6.60
e	2.54	
c	0.20	0.36
eB	7.62	9.30



5.2、SOP16

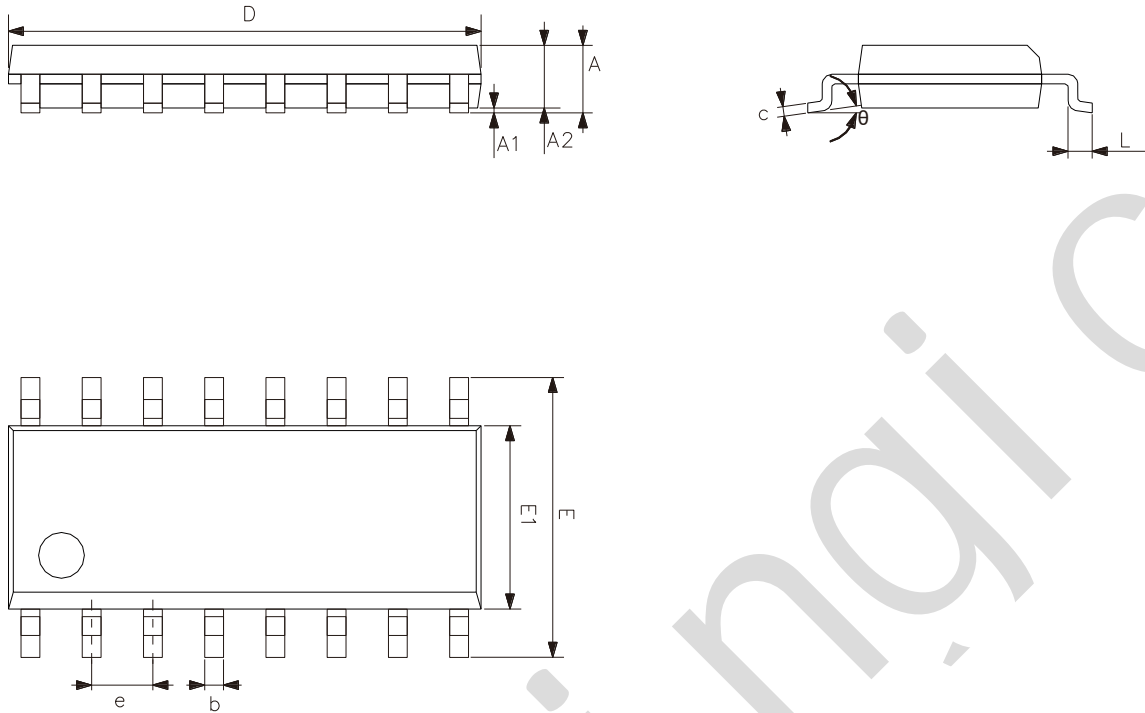

Symbol	Dimensions (mm)	
	Min.	Max.
A	1.35	1.80
A1	0.10	0.25
A2	1.25	1.55
b	0.33	0.51
c	0.19	0.25
D	9.50	10.10
E	5.80	6.30
E1	3.70	4.10
e	1.27	
L	0.35	0.89
θ	0°	8°



5.3、TSSOP16

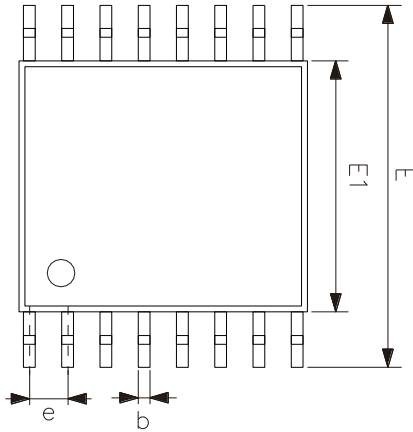
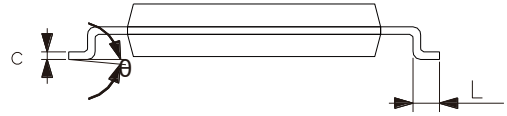
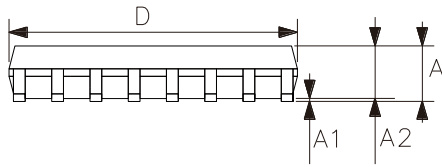

Symbol	Dimensions (mm)	
	Min.	Max.
A	-	1.20
A1	0.05	0.15
A2	0.80	1.05
b	0.19	0.30
c	0.09	0.20
D	4.90	5.10
E1	4.30	4.50
E	6.20	6.60
e	0.65	
L	0.45	0.75
θ	0°	8°



6、 Statements And Notes

6.1、 The name and content of Hazardous substances or Elements in the product

Part name	Hazardous substances or Elements									
	Lead and lead compounds	Mercury and mercury compounds	Cadmium and cadmium compounds	Hexavalent chromium compounds	Polybrominated biphenyls	Polybrominated biphenyl ethers	Dibutyl phthalate	Butylbenzyl phthalate	Di-2-ethylhexyl phthalate	Diisobutyl phthalate
Lead frame	○	○	○	○	○	○	○	○	○	○
Plastic resin	○	○	○	○	○	○	○	○	○	○
Chip	○	○	○	○	○	○	○	○	○	○
The lead	○	○	○	○	○	○	○	○	○	○
Plastic sheet installed	○	○	○	○	○	○	○	○	○	○
explanation	○: Indicates that the content of hazardous substances or elements in the detection limit of the following the SJ/T11363-2006 standard. ×: Indicates that the content of hazardous substances or elements exceeding the SJ/T11363-2006 Standard limit requirements.									

6.2、 Notion

Recommended carefully reading this information before the use of this product;

The information in this document are subject to change without notice;

This information is using to the reference only, the company is not responsible for any loss;

The company is not responsible for the any infringement of the third party patents or other rights of the responsibility.

X-ON Electronics

Largest Supplier of Electrical and Electronic Components

Click to view similar products for [Encoders, Decoders, Multiplexers & Demultiplexers](#) category:

Click to view products by [lingxingic](#) manufacturer:

Other Similar products are found below :

[MC74HC163ADTG](#) [74HC253N](#) [NLV74VHC1G01DFT1G](#) [NLVHCT4851ADTR2G](#) [NLV14028BDR2G](#) [COMX-CAR-210](#) [SN74LS148N](#)
[PI3B3251LE](#) [PI3B3251QE](#) [NLV74HC4851AMNTWG](#) [MC74LVX257DG](#) [M74HCT4851ADWR2G](#) [NL7SZ19DBVT1G](#) [PI5C3253LEX](#)
[MC74HC251ADTG](#) [MC74ACT138NG](#) [NB3L8533DTR2G](#) [NLV74AC157DR2G](#) [74HC138DT](#) [74HC153DT](#) [74HC238DT](#) [74HC151DT](#)
[ADS131M02IRUKR](#) [CBMG709ATS16](#) [74HC238N](#) [HT74HC154ARWZ](#) [RS2G139XS16-G](#) [74HCT251D](#) [74HC138T](#) [U74HC138G-S16-R](#)
[AIP74HCT138SA.TB](#) [XD74C922](#) [RS1G157XC6](#) [74HC151M/TR](#) [AiP74HC237TA16.TB](#) [AIP74HC138TA16.TB](#) [74HC138DRG](#)
[AiP74LVC138TA16.TB](#) [CD4511BDRG](#) [AiP74LVC157TA16.TB](#) [SN74HC42N\(LX\)](#) [SN74LS157N\(LX\)](#) [SN74LS42N](#) [TC4053BFT\(EL,N\)](#)
[74VHC4052AFT\(BE\)](#) [TC74VHC138FK\(EL,K\)](#) [TC74HC151AF\(EL,F\)](#) [SN74HC145DR\(LX\)](#) [SN74HC139DR\(LX\)](#) [CD4028BM\(LX\)](#)