



# SN74LS240 (LX)

## Octal Buffer/Line Driver; 3-state; Inverting

### Product Specification

#### Specification Revision History:

Version	Date	Description
2021-06-A1	2021-06	New
2023-04-B1	2023-04	Update the template



# Contents

<b>1、 General Description.....</b>	<b>3</b>
<b>2、 Block Diagram And Pin Description .....</b>	<b>6</b>
2.1、 Block Diagram .....	6
2.2、 Pin Configurations.....	7
2.3、 Pin Description .....	7
2.4、 Function Table.....	7
<b>3、 Electrical Parameter .....</b>	<b>8</b>
3.1、 Absolute Maximum Ratings.....	8
3.2、 Recommended Operating Conditions .....	8
3.3、 Electrical Characteristics .....	9
3.3.1、 DC Characteristics 1 .....	9
3.3.2、 DC Characteristics 2 .....	10
3.3.3、 DC Characteristics 3 .....	11
3.3.4、 AC Characteristics 1 .....	12
3.3.5、 AC Characteristics 2 .....	13
3.3.6、 AC Characteristics 3 .....	14
<b>4、 Testing Circuit .....</b>	<b>15</b>
4.1、 AC Testing Circuit .....	15
4.2、 AC Testing Waveforms.....	15
4.3、 Measurement Points .....	16
4.4、 Test Data .....	16
<b>5、 Package Information .....</b>	<b>17</b>
5.1、 DIP20 .....	17
5.2、 SOP20 .....	18
5.3、 TSSOP20.....	19
<b>6、 Statements And Notes .....</b>	<b>20</b>
6.1、 The name and content of Hazardous substances or Elements in the product .....	20
6.2、 Notes .....	20



灵星芯微 集成电路

## 1、General Description

The SN74LS240 is an 8-bit inverting buffer/line driver with 3-state outputs. The device can be used as two 4-bit buffers or one 8-bit buffer. The device features two output enables ( $1\overline{OE}$  and  $2\overline{OE}$ ), each controlling four of the 3-state outputs. A HIGH on  $n\overline{OE}$  causes the outputs to assume a high-impedance OFF-state. Inputs include clamp diodes that enable the use of current limiting resistors to interface inputs to voltages in excess of  $V_{CC}$ .

### Features:

- Inverting 3-state outputs
- Specified from  $-40^{\circ}\text{C}$  to  $+125^{\circ}\text{C}$
- Packaging information: DIP20/SOP20/TSSOP20



灵星芯微 集成电路

**Ordering Information:**

**Tube packing specifications:**

Part number	Packaging form	Marking code	Tube quantity	Boxed tube quantity	Boxed quantity	Notes
SN74LS240N (LX)	DIP20	SN74LS240N	18 PCS/tube	40 tube/box	720 PCS/box	Dimensions of plastic enclosure: 26.3mm×6.4mm Pin spacing: 2.54mm
SN74LS240D(LX)	SOP20	LS240	35 PCS/tube	80 tube/box	2800 PCS/box	Dimensions of plastic enclosure: 12.8mm×7.5mm Pin spacing: 1.27mm
SN74LS240PW(LX)	TSSOP20	LS240	70 PCS/tube	200 tube/box	14000 PCS/box	Dimensions of plastic enclosure: 6.5mm×4.4mm Pin spacing: 0.65mm



灵星芯微 精密制程

**Reel packing specifications:**

Part number	Packaging form	Marking code	Reel quantity	Boxed reel quantity	Notes
SN74LS240DWR(LX)	SOP20	LS240	2000PCS/reel	2000PCS/box	Dimensions of plastic enclosure:12.8mm×7.5mm Pin spacing:1.27mm
SN74LS240PW(LX)	TSSOP20	LS240	4000PCS/reel	8000PCS/box	Dimensions of plastic enclosure:6.5mm×4.4mm Pin spacing:0.65mm

Note: If the physical information is inconsistent with the ordering information, please refer to the actual product.



灵星芯微 集成电路

## 2、Block Diagram And Pin Description

### 2.1、Block Diagram

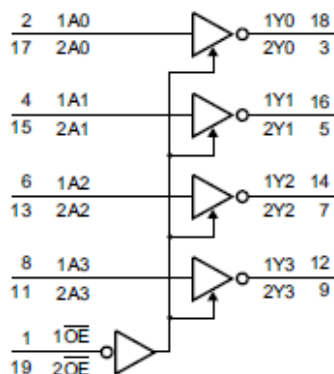

Figure 1. Logic symbol

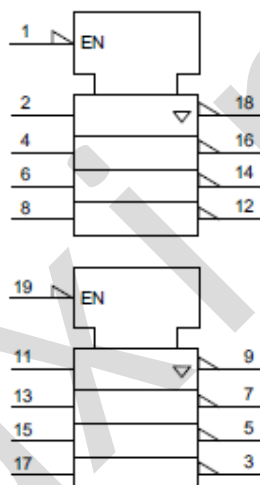

Figure 2. IEC logic symbol

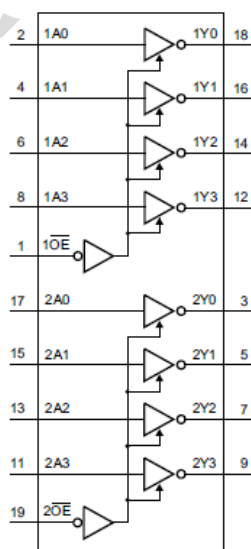
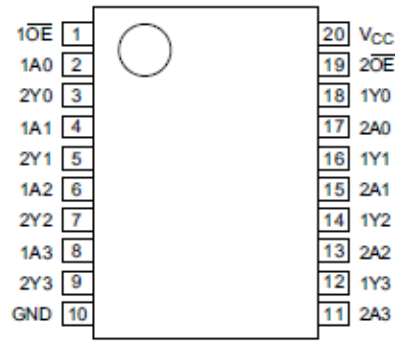

Figure 3. Functional diagram



## 2.2、Pin Configurations



## 2.3、Pin Description

Pin No.	Pin Name	Description
1	1OE	output enable input (active LOW)
2	1A0	data input
3	2Y0	bus output
4	1A1	data input
5	2Y1	bus output
6	1A2	data input
7	2Y2	bus output
8	1A3	data input
9	2Y3	bus output
10	GND	ground (0V)
11	2A3	data input
12	1Y3	bus output
13	2A2	data input
14	1Y2	bus output
15	2A1	data input
16	1Y1	bus output
17	2A0	data input
18	1Y0	bus output
19	2OE	output enable input (active LOW)
20	V <sub>CC</sub>	supply voltage

## 2.4、Function Table

Input		Output
nOE	nAn	nYn
L	L	H
L	H	L
H	X	Z

Note: H=HIGH voltage level; L=LOW voltage level; X=don't care; Z=high-impedance OFF-state.



### 3、Electrical Parameter

#### 3.1、Absolute Maximum Ratings

(Voltages are referenced to GND(ground=0V), unless otherwise specified.)

Parameter	Symbol	Conditions	Min.	Max.	Unit	
supply voltage	$V_{CC}$	-	-0.5	+7.0	V	
input clamping current	$I_{IK}$	$V_I < -0.5V$ or $V_I > V_{CC}+0.5V$	-	$\pm 20$	mA	
output clamping current	$I_{OK}$	$V_O < -0.5V$ or $V_O > V_{CC}+0.5V$	-	$\pm 20$	mA	
output current	$I_O$	$-0.5V < V_O < V_{CC}+0.5V$	-	$\pm 35$	mA	
supply current	$I_{CC}$	-	-	70	mA	
ground current	$I_{GND}$	-	-70	-	mA	
storage temperature	$T_{stg}$	-	-65	+150	°C	
total power dissipation	$P_{tot}$	-	-	500	mW	
Soldering temperature	$T_L$	10s	DIP		245	°C
			SOP/TSSOP		260	°C

#### 3.2、Recommended Operating Conditions

Parameter	Symbol	Conditions	Min.	Typ.	Max.	Unit
supply voltage	$V_{CC}$	-	2.0	5.0	6.0	V
input voltage	$V_I$	-	0	-	$V_{CC}$	V
output voltage	$V_O$	-	0	-	$V_{CC}$	V
input transition rise and fall rate	$\Delta t/\Delta V$	$V_{CC}=2.0V$	-	-	625	ns/V
		$V_{CC}=4.5V$	-	1.67	139	ns/V
		$V_{CC}=6.0V$	-	-	83	ns/V
ambient temperature	$T_{amb}$	-	-40	-	+125	°C





### 3.3、Electrical Characteristics

#### 3.3.1、DC Characteristics 1

( $T_{amb}=25^{\circ}\text{C}$ , voltages are referenced to GND (ground=0V), unless otherwise specified.)

Parameter	Symbol	Conditions	Min.	Typ.	Max.	Unit	
HIGH-level input voltage	$V_{IH}$	$V_{CC}=2.0\text{V}$	1.5	1.2	-	V	
		$V_{CC}=4.5\text{V}$	3.15	2.4	-	V	
		$V_{CC}=6.0\text{V}$	4.2	3.2	-	V	
LOW-level input voltage	$V_{IL}$	$V_{CC}=2.0\text{V}$	-	0.8	0.5	V	
		$V_{CC}=4.5\text{V}$	-	2.1	1.35	V	
		$V_{CC}=6.0\text{V}$	-	2.8	1.8	V	
HIGH-level output voltage	$V_{OH}$	$V_I = V_{IH} \text{ or } V_{IL}$	$I_O=-20\mu\text{A}; V_{CC}=2.0\text{V}$	1.9	2.0	-	V
			$I_O=-20\mu\text{A}; V_{CC}=4.5\text{V}$	4.4	4.5	-	V
			$I_O=-20\mu\text{A}; V_{CC}=6.0\text{V}$	5.9	6.0	-	V
			$I_O=-6.0\text{mA}; V_{CC}=4.5\text{V}$	3.98	4.32	-	V
			$I_O=-7.8\text{mA}; V_{CC}=6.0\text{V}$	5.48	5.81	-	V
LOW-level output voltage	$V_{OL}$	$V_I = V_{IH} \text{ or } V_{IL}$	$I_O=20\mu\text{A}; V_{CC}=2.0\text{V}$	-	0	0.1	V
			$I_O=20\mu\text{A}; V_{CC}=4.5\text{V}$	-	0	0.1	V
			$I_O=20\mu\text{A}; V_{CC}=6.0\text{V}$	-	0	0.1	V
			$I_O=6.0\text{mA}; V_{CC}=4.5\text{V}$	-	0.15	0.26	V
			$I_O=7.8\text{mA}; V_{CC}=6.0\text{V}$	-	0.16	0.26	V
input leakage current	$I_I$	$V_I=V_{CC} \text{ or } \text{GND}; V_{CC}=6.0\text{V}$	-	-	$\pm 1.0$	$\mu\text{A}$	
OFF-state output current	$I_{OZ}$	$V_I=V_{IH} \text{ or } V_{IL}; V_{CC}=6.0\text{V}; V_O=V_{CC} \text{ or } \text{GND}$	-	-	$\pm 1.0$	$\mu\text{A}$	
supply current	$I_{CC}$	$V_I=V_{CC} \text{ or } \text{GND}; I_O=0\text{A}; V_{CC}=6.0\text{V}$	-	-	8.0	$\mu\text{A}$	
input capacitance	$C_I$	-	-	3.5	-	pF	



### 3.3.2、DC Characteristics 2

( $T_{amb}=-40^{\circ}\text{C}$  to  $+85^{\circ}\text{C}$ , voltages are referenced to GND (ground=0V), unless otherwise specified.)

Parameter	Symbol	Conditions	Min.	Typ.	Max.	Unit	
HIGH-level input voltage	$V_{IH}$	$V_{CC}=2.0\text{V}$	1.5	-	-	V	
		$V_{CC}=4.5\text{V}$	3.15	-	-	V	
		$V_{CC}=6.0\text{V}$	4.2	-	-	V	
LOW-level input voltage	$V_{IL}$	$V_{CC}=2.0\text{V}$	-	-	0.5	V	
		$V_{CC}=4.5\text{V}$	-	-	1.35	V	
		$V_{CC}=6.0\text{V}$	-	-	1.8	V	
HIGH-level output voltage	$V_{OH}$	$V_I = V_{IH} \text{ or } V_{IL}$	$I_O=-20\mu\text{A}; V_{CC}=2.0\text{V}$	1.9	-	-	V
			$I_O=-20\mu\text{A}; V_{CC}=4.5\text{V}$	4.4	-	-	V
			$I_O=-20\mu\text{A}; V_{CC}=6.0\text{V}$	5.9	-	-	V
			$I_O=-6.0\text{mA}; V_{CC}=4.5\text{V}$	3.84	-	-	V
			$I_O=-7.8\text{mA}; V_{CC}=6.0\text{V}$	5.34	-	-	V
LOW-level output voltage	$V_{OL}$	$V_I = V_{IH} \text{ or } V_{IL}$	$I_O=20\mu\text{A}; V_{CC}=2.0\text{V}$	-	-	0.1	V
			$I_O=20\mu\text{A}; V_{CC}=4.5\text{V}$	-	-	0.1	V
			$I_O=20\mu\text{A}; V_{CC}=6.0\text{V}$	-	-	0.1	V
			$I_O=6.0\text{mA}; V_{CC}=4.5\text{V}$	-	-	0.33	V
			$I_O=7.8\text{mA}; V_{CC}=6.0\text{V}$	-	-	0.33	V
input leakage current	$I_I$	$V_I=V_{CC} \text{ or } \text{GND}; V_{CC}=6.0\text{V}$	-	-	$\pm 1.0$	$\mu\text{A}$	
OFF-state output current	$I_{OZ}$	$V_I=V_{IH} \text{ or } V_{IL}; V_{CC}=6.0\text{V}; V_O=V_{CC} \text{ or } \text{GND}$	-	-	$\pm 5.0$	$\mu\text{A}$	
supply current	$I_{CC}$	$V_I=V_{CC} \text{ or } \text{GND}; I_O=0\text{A}; V_{CC}=6.0\text{V}$	-	-	80	$\mu\text{A}$	



### 3.3.3、DC Characteristics 3

( $T_{amb} = -40^{\circ}\text{C}$  to  $+125^{\circ}\text{C}$ , voltages are referenced to GND (ground=0V), unless otherwise specified.)

Parameter	Symbol	Conditions	Min.	Typ.	Max.	Unit	
HIGH-level input voltage	$V_{IH}$	$V_{CC}=2.0\text{V}$	1.5	-	-	V	
		$V_{CC}=4.5\text{V}$	3.15	-	-	V	
		$V_{CC}=6.0\text{V}$	4.2	-	-	V	
LOW-level input voltage	$V_{IL}$	$V_{CC}=2.0\text{V}$	-	-	0.5	V	
		$V_{CC}=4.5\text{V}$	-	-	1.35	V	
		$V_{CC}=6.0\text{V}$	-	-	1.8	V	
HIGH-level output voltage	$V_{OH}$	$V_I = V_{IH} \text{ or } V_{IL}$	$I_O = -20\mu\text{A}; V_{CC} = 2.0\text{V}$	1.9	-	-	V
			$I_O = -20\mu\text{A}; V_{CC} = 4.5\text{V}$	4.4	-	-	V
			$I_O = -20\mu\text{A}; V_{CC} = 6.0\text{V}$	5.9	-	-	V
			$I_O = -6.0\text{mA}; V_{CC} = 4.5\text{V}$	3.7	-	-	V
			$I_O = -7.8\text{mA}; V_{CC} = 6.0\text{V}$	5.2	-	-	V
LOW-level output voltage	$V_{OL}$	$V_I = V_{IH} \text{ or } V_{IL}$	$I_O = 20\mu\text{A}; V_{CC} = 2.0\text{V}$	-	-	0.1	V
			$I_O = 20\mu\text{A}; V_{CC} = 4.5\text{V}$	-	-	0.1	V
			$I_O = 20\mu\text{A}; V_{CC} = 6.0\text{V}$	-	-	0.1	V
			$I_O = 6.0\text{mA}; V_{CC} = 4.5\text{V}$	-	-	0.4	V
			$I_O = 7.8\text{mA}; V_{CC} = 6.0\text{V}$	-	-	0.4	V
input leakage current	$I_I$	$V_I = V_{CC} \text{ or } \text{GND}; V_{CC} = 6.0\text{V}$	-	-	$\pm 1.0$	$\mu\text{A}$	
OFF-state output current	$I_{OZ}$	$V_I = V_{IH} \text{ or } V_{IL}; V_{CC} = 6.0\text{V}; V_O = V_{CC} \text{ or } \text{GND}$	-	-	$\pm 10$	$\mu\text{A}$	
supply current	$I_{CC}$	$V_I = V_{CC} \text{ or } \text{GND}; I_O = 0\text{A}; V_{CC} = 6.0\text{V}$	-	-	160	$\mu\text{A}$	



### 3.3.4、AC Characteristics 1

( $T_{amb}=25^{\circ}C$ , voltages are referenced to GND (ground=0V), unless otherwise specified.)

Parameter	Symbol	Conditions	Min.	Typ.	Max.	Unit	
nAn to nYn propagation delay	$t_{pd}$	see Figure 5	$V_{CC}=2.0V$	-	30	100	ns
			$V_{CC}=4.5V$	-	11	20	ns
			$V_{CC}=5.0V; C_L=15pF$	-	9	-	ns
			$V_{CC}=6.0V$	-	9	17	ns
nOE to nYn enable time	$t_{en}$	see Figure 6	$V_{CC}=2.0V$	-	39	150	ns
			$V_{CC}=4.5V$	-	14	30	ns
			$V_{CC}=6.0V$	-	11	26	ns
nOE to nYn disable time	$t_{dis}$	see Figure 6	$V_{CC}=2.0V$	-	41	150	ns
			$V_{CC}=4.5V$	-	15	30	ns
			$V_{CC}=6.0V$	-	12	26	ns
transition time	$t_t$	see Figure 5	$V_{CC}=2.0V$	-	14	60	ns
			$V_{CC}=4.5V$	-	5	12	ns
			$V_{CC}=6.0V$	-	4	10	ns
power dissipation capacitance	$C_{PD}$	per buffer; $V_I=GND$ to $V_{CC}$	-	30	-	pF	

Note:

[1]  $t_{pd}$  is the same as  $t_{PLH}$  and  $t_{PHL}$ .

[2]  $t_{en}$  is the same as  $t_{PZL}$  and  $t_{PZH}$ .

[3]  $t_{dis}$  is the same as  $t_{PLZ}$  and  $t_{PHZ}$ .

[4]  $t_t$  is the same as  $t_{THL}$  and  $t_{TLH}$ .

[5]  $C_{PD}$  is used to determine the dynamic power dissipation ( $P_D$  in uW).

$$P_D = C_{PD} \times V_{CC}^2 \times f_i \times N + \sum (C_L \times V_{CC}^2 \times f_o) \text{ where:}$$

$f_i$ =input frequency in MHz;

$f_o$ =output frequency in MHz;

$C_L$ =output load capacitance in pF;

$V_{CC}$ =supply voltage in V;

$N$ =number of inputs switching;

$\sum (C_L \times V_{CC}^2 \times f_o)$ =sum of outputs.



### 3.3.5、AC Characteristics 2

( $T_{amb} = -40^{\circ}\text{C}$  to  $+85^{\circ}\text{C}$ , voltages are referenced to GND (ground=0V), unless otherwise specified.)

Parameter	Symbol	Conditions	Min.	Typ.	Max.	Unit	
nAn to nYn propagation delay	$t_{pd}$	see Figure 5	$V_{CC}=2.0\text{V}$	-	-	125	ns
			$V_{CC}=4.5\text{V}$	-	-	25	ns
			$V_{CC}=6.0\text{V}$	-	-	21	ns
nOE $\bar{}$ to nYn enable time	$t_{en}$	see Figure 6	$V_{CC}=2.0\text{V}$	-	-	190	ns
			$V_{CC}=4.5\text{V}$	-	-	38	ns
			$V_{CC}=6.0\text{V}$	-	-	33	ns
nOE $\bar{}$ to nYn disable time	$t_{dis}$	see Figure 6	$V_{CC}=2.0\text{V}$	-	-	190	ns
			$V_{CC}=4.5\text{V}$	-	-	38	ns
			$V_{CC}=6.0\text{V}$	-	-	33	ns
transition time	$t_t$	see Figure 5	$V_{CC}=2.0\text{V}$	-	-	75	ns
			$V_{CC}=4.5\text{V}$	-	-	15	ns
			$V_{CC}=6.0\text{V}$	-	-	13	ns

Note:

- [1]  $t_{pd}$  is the same as  $t_{PLH}$  and  $t_{PHL}$ .
- [2]  $t_{en}$  is the same as  $t_{PZL}$  and  $t_{PZH}$ .
- [3]  $t_{dis}$  is the same as  $t_{PLZ}$  and  $t_{PHZ}$ .
- [4]  $t_t$  is the same as  $t_{THL}$  and  $t_{TLH}$ .



### 3.3.6、AC Characteristics 3

( $T_{amb} = -40^{\circ}\text{C}$  to  $+125^{\circ}\text{C}$ , voltages are referenced to GND (ground=0V), unless otherwise specified.)

Parameter	Symbol	Conditions	Min.	Typ.	Max.	Unit	
nAn to nYn propagation delay	$t_{pd}$	see Figure 5	$V_{CC}=2.0\text{V}$	-	-	150	ns
			$V_{CC}=4.5\text{V}$	-	-	30	ns
			$V_{CC}=6.0\text{V}$	-	-	26	ns
nOE $\bar{}$ to nYn enable time	$t_{en}$	see Figure 6	$V_{CC}=2.0\text{V}$	-	-	225	ns
			$V_{CC}=4.5\text{V}$	-	-	45	ns
			$V_{CC}=6.0\text{V}$	-	-	38	ns
nOE $\bar{}$ to nYn disable time	$t_{dis}$	see Figure 6	$V_{CC}=2.0\text{V}$	-	-	225	ns
			$V_{CC}=4.5\text{V}$	-	-	45	ns
			$V_{CC}=6.0\text{V}$	-	-	38	ns
transition time	$t_t$	see Figure 5	$V_{CC}=2.0\text{V}$	-	-	90	ns
			$V_{CC}=4.5\text{V}$	-	-	18	ns
			$V_{CC}=6.0\text{V}$	-	-	15	ns

Note:

- [1]  $t_{pd}$  is the same as  $t_{PLH}$  and  $t_{PHL}$ .
- [2]  $t_{en}$  is the same as  $t_{PZL}$  and  $t_{PZH}$ .
- [3]  $t_{dis}$  is the same as  $t_{PLZ}$  and  $t_{PHZ}$ .
- [4]  $t_t$  is the same as  $t_{THL}$  and  $t_{TLH}$ .



## 4、Testing Circuit

### 4.1、AC Testing Circuit

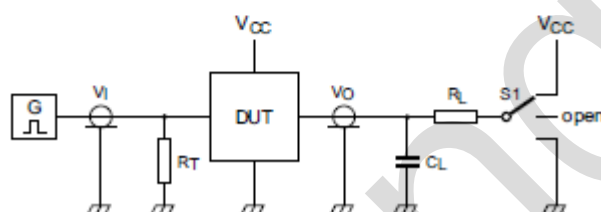
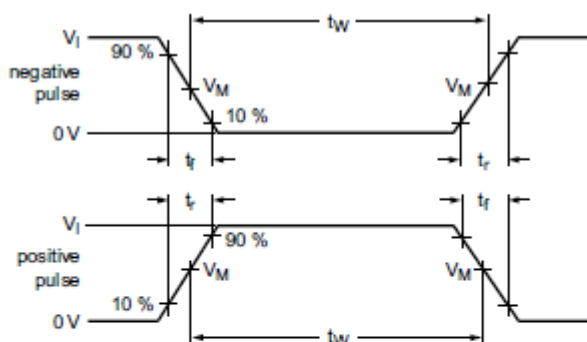

Figure 4. Test circuit for measuring switching times

Definitions for test circuit:

$R_L$ =Load resistance.

$C_L$ =Load capacitance including jig and probe capacitance.

$R_T$ =Termination resistance should be equal to the output impedance  $Z_o$  of the pulse generator.

S1=Test selection switch.

### 4.2、AC Testing Waveforms

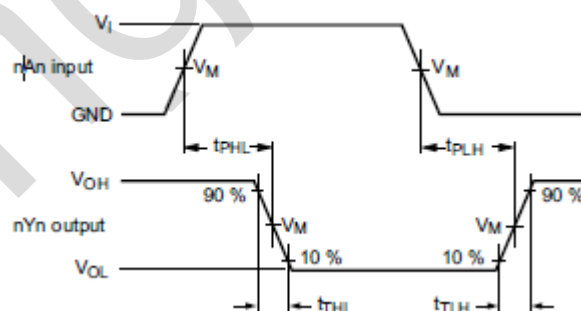

Figure 5. Input (nAn) to output (nYn) propagation delays and output transition times

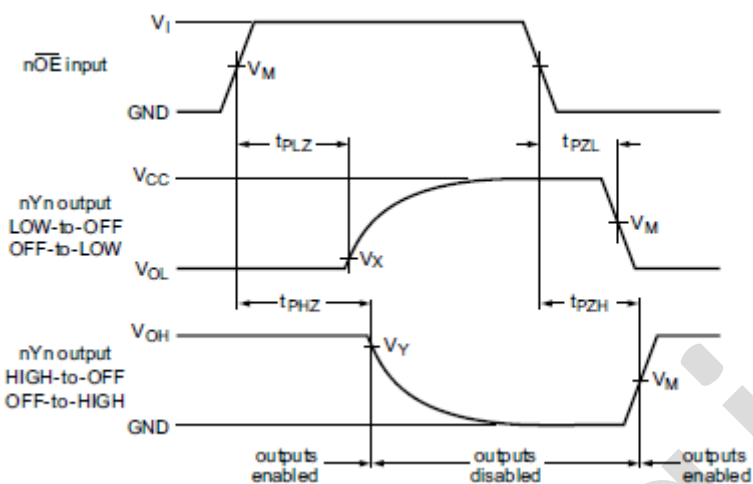

Figure 6. 3-state enable and disable times

#### 4.3、 Measurement Points

Input	Output		
$V_M$	$V_M$	$V_X$	$V_Y$
$0.5 \times V_{CC}$	$0.5 \times V_{CC}$	$0.1 \times V_{CC}$	$0.9 \times V_{CC}$

#### 4.4、 Test Data

Input		Load		S1 position		
$V_I$	$t_r, t_f$	$C_L$	$R_L$	$t_{PHL},$ $t_{PLH}$	$t_{PZH},$ $t_{PHZ}$	$t_{PZL},$ $t_{PLZ}$
$V_{CC}$	6ns	15pF, 50pF	1k $\Omega$	open	GND	$V_{CC}$





## 5、Package Information

### 5.1、DIP20

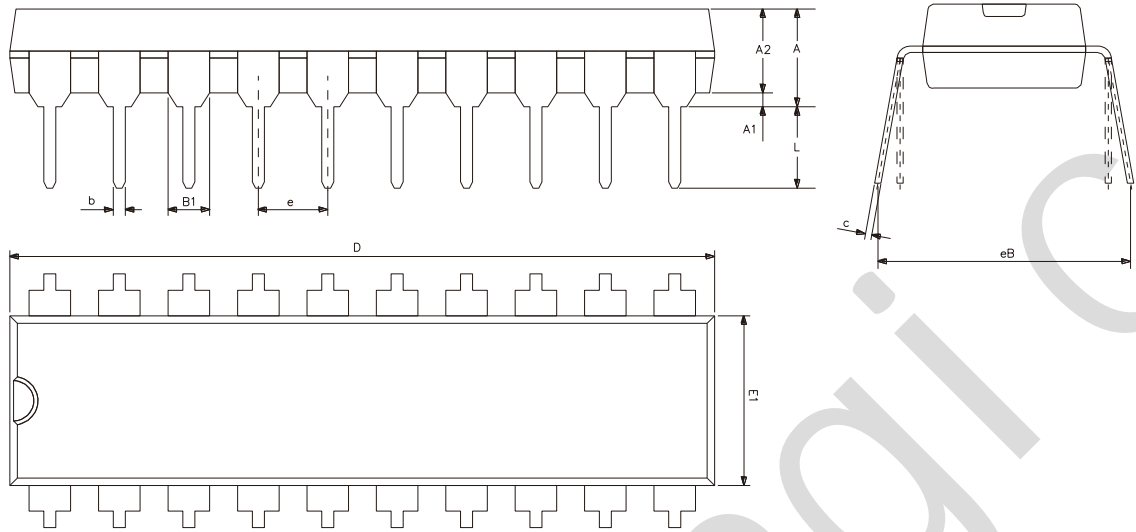

Symbol	Dimensions (mm)	
	Min.	Max.
A	3.60	5.33
A1	0.51	-
A2	3.20	3.60
b	0.36	0.53
B1	1.52	
c	0.204	0.36
D	25.70	26.54
E1	6.20	6.75
e	2.54	
eB	7.62	9.30
L	3.00	3.60



## 5.2、SOP20

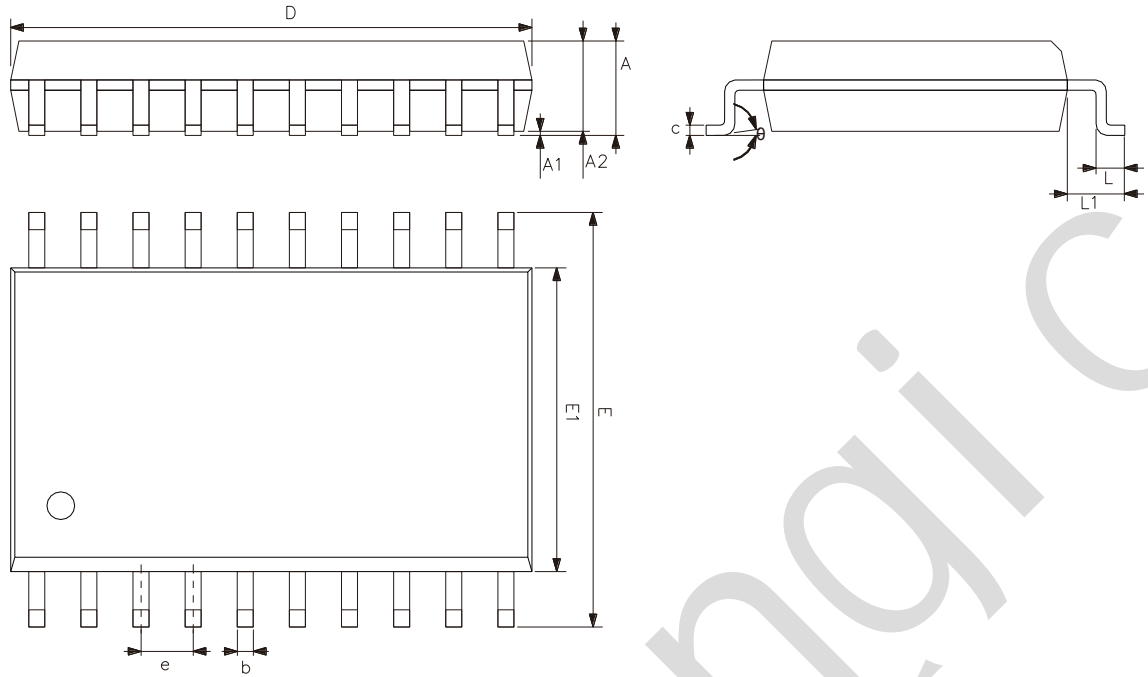

Symbol	Dimensions (mm)	
	Min.	Max.
A	2.47	2.65
A1	0.05	0.30
A2	2.20	2.44
b	0.35	0.50
c	0.15	0.30
D	12.54	12.94
E	10.00	10.60
E1	7.30	7.70
e	1.27	
L	0.40	1.05
L1	1.30	1.50
$\theta$	0°	8°



### 5.3、TSSOP20

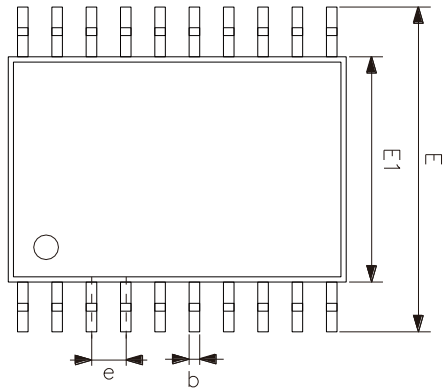
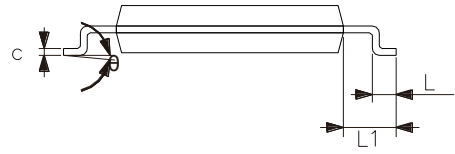
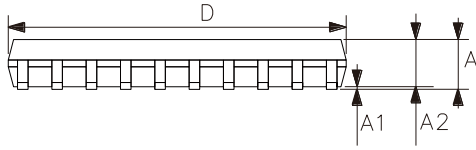

Symbol	Dimensions (mm)	
	Min.	Max.
A	-	1.20
A1	0.05	0.15
A2	0.80	1.05
b	0.19	0.30
c	0.09	0.20
D	6.40	6.60
E1	4.30	4.50
E	6.20	6.60
e	0.65	
L	0.45	0.75
L1	1.00	
$\theta$	0°	8°



灵星芯微 集成电路

## 6、 Statements And Notes

### 6.1、 The name and content of Hazardous substances or Elements in the product

Part name	Hazardous substances or Elements									
	Lead and lead compounds	Mercury and mercury compounds	Cadmium and cadmium compounds	Hexavalent chromium compounds	Polybrominated biphenyls	Polybrominated biphenyl ethers	Dibutyl phthalate	Butylbenzyl phthalate	Di-2-ethylhexyl phthalate	Diisobutyl phthalate
Lead frame	○	○	○	○	○	○	○	○	○	○
Plastic resin	○	○	○	○	○	○	○	○	○	○
Chip	○	○	○	○	○	○	○	○	○	○
The lead	○	○	○	○	○	○	○	○	○	○
Plastic sheet installed	○	○	○	○	○	○	○	○	○	○
explanation	○: Indicates that the content of hazardous substances or elements in the detection limit of the following the SJ/T11363-2006 standard. ×: Indicates that the content of hazardous substances or elements exceeding the SJ/T11363-2006 Standard limit requirements.									

### 6.2、 Notes

We Recommend you to read this chapter carefully before using this product.

The information in this chapter is provided for reference only and Lingxing disclaims any express or implied warranties, including but not limited to applicability, special application or non-infringement of third party rights.

This product is not suitable for critical equipment such as life-saving, life-sustaining or safety equipment. It is also not suitable for applications that may result in personal injury, death, or serious property or environmental damage due to product malfunction or failure. Lingxing will not be liable for any damages incurred by the customers at their own risk for such applications.

The customer is responsible for conducting all necessary tests Lingxing's application to avoid failure in the application or the application of the customer's third party users. Lingxing does not accept any liability.

The Company reserves the right to change or improve the information published in this chapter at any time. The information in this chapter are subject to change without notice. We recommend the customer to consult our sales staff before purchasing.

Please obtain related materials form Lingxing's regular channels and we are not responsible for its content if it is provided by sources other than our company.

In case of any conflict between the Chinese and English version, the version is subject to the Chinese one.

## X-ON Electronics

Largest Supplier of Electrical and Electronic Components

*Click to view similar products for [Buffers & Line Drivers](#) category:*

*Click to view products by [lingxingic](#) manufacturer:*

Other Similar products are found below :

[LXV200-024SW](#) [74AUP2G34FW3-7](#) [HEF4043BP](#) [NL17SG125DFT2G](#) [NLU1GT126CMUTCG](#) [CD4041UBE](#) [54FCT240CTDB](#)  
[74HCT540N](#) [DS14C88N](#) [070519XB](#) [NL17SZ07P5T5G](#) [74LVC2G17FW4-7](#) [CD4502BE](#) [5962-8982101PA](#) [NL17SH17P5T5G](#)  
[74HCT126T14-13](#) [74VHC9126FT\(BJ\)](#) [RHRXH162244K1](#) [74AUP1G34FW5-7](#) [74AUP1G07FW5-7](#) [74LVC1G126FW4-7](#)  
[74LVC2G126RA3-7](#) [74LVCE1G125FZ4-7](#) [74AUP1G126FW5-7](#) [54FCT240TLB](#) [74LVCE1G07FZ4-7](#) [NLX3G16DMUTCG](#)  
[NLX2G06AMUTCG](#) [LE87100NQCT](#) [LE87285NQC](#) [LE87290YQC](#) [LE87290YQCT](#) [74AUP1G125FW5-7](#) [NLU2G16CMUTCG](#)  
[MC74LCX244MN2TWG](#) [NL17SG17P5T5G](#) [NLV74HC125ADR2G](#) [NLVHCT245ADTR2G](#) [NLVVHC1G126DFT2G](#) [EL5623IRZ](#)  
[ISL15102AIRZ-T13](#) [ISL1539IRZ-T13](#) [MC100EP17MNG](#) [MC74HCT365ADR2G](#) [MC74LCX244ADTR2G](#) [NL27WZ126US](#) [NL37WZ16US](#)  
[NLU1G07MUTCG](#) [NLU2G07MUTCG](#) [NLX3G17BMX1TCG](#)