



# SN74LS283

## 4-bit Binary Full Adder with Fast Carry

### Product Specification

#### Specification Revision History:

Version	Date	Description
2012-06-A1	2012-06	New
2021-12-A2	2021-12	Modify ordering information
2022-01-A3	2022-01	Modify ambient temperature to $-40^{\circ}\text{C}\sim+105^{\circ}\text{C}$ and add electrical characteristics of $-40^{\circ}\text{C}\sim+105^{\circ}\text{C}$
2023-11-A4	2023-11	Modify ambient temperature to $-40^{\circ}\text{C}\sim+125^{\circ}\text{C}$ and modify ordering information



## 1、 General Description

The SN74LS283 adds two 4-bit binary words (A<sub>n</sub> plus B<sub>n</sub>) plus the incoming carry (CIN). The binary sum appears on the sum outputs (S1 to S4) and the out-going carry (COUT) according to the equation:

$$CIN+(A1+B1)+2(A2+B2)+4(A3+B3)+8(A4+B4)=S1+2S2+4S3+8S4+16COUT$$

Where (+) = plus.

Due to the symmetry of the binary add function, the SN74LS283 can be used with either all active HIGH operands (positive logic) or all active LOW operands (negative logic). In case of all active LOW operands the results S1 to S4 and COUT should be interpreted also as active LOW. With active HIGH inputs, CIN must be held LOW when no carry in is intended. Interchanging inputs of equal weight does not affect the operation, thus CIN, A1, B1 can be assigned arbitrarily to pins 5, 6, 7, etc.

### Features:

- High-speed 4-bit binary addition
- Cascadable in 4-bit increments
- Fast internal look-ahead carry
- Low-power dissipation
- Specified from -40°C to +125°C
- Packaging information: DIP16/SOP16



**Ordering Information:**

**Tube packing specifications:**

Part number	Packaging form	Marking code	Tube quantity	Boxed tube quantity	Boxed quantity	Notes
SN74LS283N	DIP16	SN74LS283N	25 PCS/tube	40 tube/box	1000 PCS/box	Dimensions of plastic enclosure: 19.0mm×6.4mm Pin spacing: 2.54mm
SN74LS283DR	SOP16	LS283	50 PCS/tube	200 tube/box	10000 PCS/box	Dimensions of plastic enclosure: 10.0mm×3.9mm Pin spacing: 1.27mm

**Reel packing specifications:**

Part number	Packaging form	Marking code	Reel quantity	Boxed reel quantity	Notes
SN74LS283DR	SOP16	LS283	2500 PCS/reel	5000 PCS/box	Dimensions of plastic enclosure: 10.0mm×3.9mm Pin spacing:1.27mm

Note: If the physical information is inconsistent with the ordering information, please refer to the actual product.



## 2、Block Diagram And Pin Description

### 2.1、Block Diagram

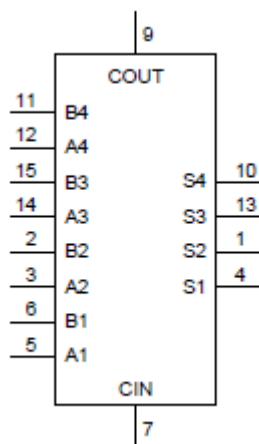

Figure 1. Logic symbol

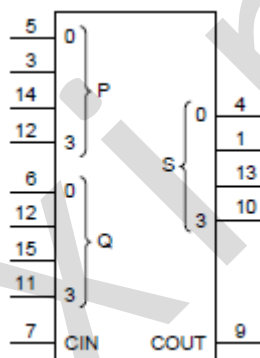

Figure 2. IEC logic symbol

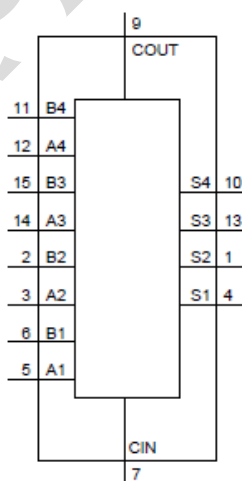

Figure 3. Functional diagram

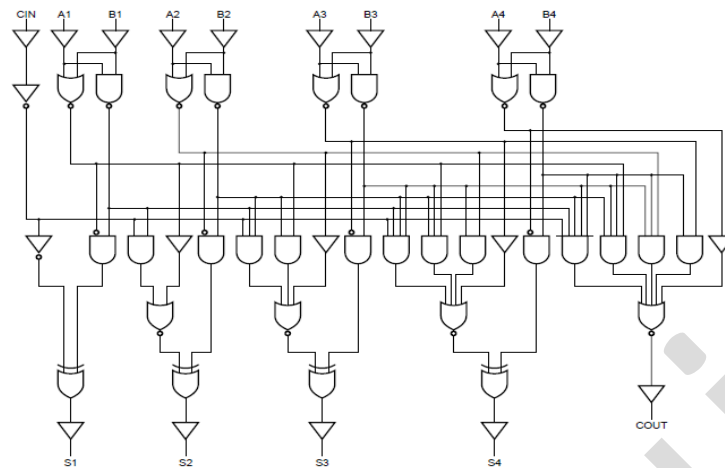
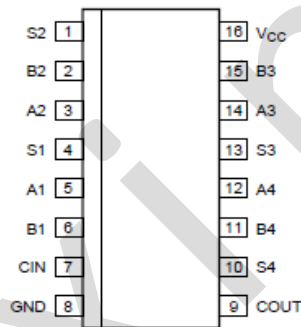

Figure 4. Logic diagram

## 2.2、Pin Configurations



## 2.3、Pin Description

Pin No.	Pin Name	Description
1	S2	sum output 2
2	B2	B operand input 2
3	A2	A operand input 2
4	S1	sum output 1
5	A1	A operand input 1
6	B1	B operand input 1
7	CIN	carry input
8	GND	ground (0V)
9	COUT	carry output
10	S4	sum output 4
11	B4	B operand input 4
12	A4	A operand input 4
13	S3	sum output 3
14	A3	A operand input 3
15	B3	B operand input 3
16	V <sub>cc</sub>	supply voltage



## 2.4、Function Table

Pins	Input									Output				
	CIN	A4	A3	A2	A1	B4	B3	B2	B1	COU <sub>T</sub>	S4	S3	S2	S1
Logic levels	L	H	L	H	L	H	L	L	H	H	L	L	H	H
Active HIGH	0	1	0	1	0	1	0	0	1	1	0	0	1	1
Active LOW	1	0	1	0	1	0	1	1	0	0	1	1	0	0

Note:

[1] H=HIGH voltage level; L=LOW voltage level.

[2] Example for active HIGH:  $10+9 (0+1010+1001) =19 (10011)$ .

[3] Example for active LOW:  $5+6 (1+0101+0110) =12 (01100)$ .

## 3、Electrical Parameter

### 3.1、Absolute Maximum Ratings

(Voltages are referenced to GND(ground=0V), unless otherwise specified.)

Parameter	Symbol	Conditions	Min.	Max.	Unit
supply voltage	$V_{CC}$	-	-0.5	+7.0	V
input clamping current	$I_{IK}$	$V_I < -0.5V$ or $V_I > V_{CC}+0.5V$	-	$\pm 20$	mA
output clamping current	$I_{OK}$	$V_O < -0.5V$ or $V_O > V_{CC}+0.5V$	-	$\pm 20$	mA
output current	$I_O$	$V_O = -0.5V$ to $V_{CC}+0.5V$	-	$\pm 25$	mA
supply current	$I_{CC}$	-	-	+50	mA
ground current	$I_{GND}$	-	-50	-	mA
storage temperature	$T_{stg}$	-	-65	+150	°C
total power dissipation	$P_{tot}$	-	-	500	mW
Soldering temperature	$T_L$	10s	DIP	245	°C
			SOP	260	

Note:

[1] For DIP16 packages: above 70°C the value of  $P_{tot}$  derates linearly with 12mW/K.

[2] For SOP16 packages: above 70°C the value of  $P_{tot}$  derates linearly with 8mW/K.



### 3.2、Recommended Operating Conditions

Parameter	Symbol	Conditions	Min.	Typ.	Max.	Unit
supply voltage	$V_{CC}$	-	2.0	5.0	6.0	V
input voltage	$V_I$	-	0	-	$V_{CC}$	V
output voltage	$V_O$	-	0	-	$V_{CC}$	V
input transition rise and fall rate	$\Delta t/\Delta V$	$V_{CC}=2.0V$	-	-	625	ns/V
		$V_{CC}=4.5V$	-	1.67	139	ns/V
		$V_{CC}=6.0V$	-	-	83	ns/V
ambient temperature	$T_{amb}$	-	-40	-	+125	°C

### 3.3、Electrical Characteristics

#### 3.3.1、DC Characteristics 1

( $T_{amb}=25^{\circ}C$ , voltages are referenced to GND (ground=0V), unless otherwise specified.)

Parameter	Symbol	Conditions	Min.	Typ.	Max.	Unit	
HIGH-level input voltage	$V_{IH}$	$V_{CC}=2.0V$	1.5	1.2	-	V	
		$V_{CC}=4.5V$	3.15	2.4	-	V	
		$V_{CC}=6.0V$	4.2	3.2	-	V	
LOW-level input voltage	$V_{IL}$	$V_{CC}=2.0V$	-	0.8	0.5	V	
		$V_{CC}=4.5V$	-	2.1	1.35	V	
		$V_{CC}=6.0V$	-	2.8	1.8	V	
HIGH-level output voltage	$V_{OH}$	$V_I = V_{IH} \text{ or } V_{IL}$	$I_O=-20\mu A; V_{CC}=2.0V$	1.9	2.0	-	V
			$I_O=-20\mu A; V_{CC}=4.5V$	4.4	4.5	-	V
			$I_O=-20\mu A; V_{CC}=6.0V$	5.9	6.0	-	V
			$I_O=-4.0mA; V_{CC}=4.5V$	3.98	4.32	-	V
			$I_O=-5.2mA; V_{CC}=6.0V$	5.48	5.81	-	V
LOW-level output voltage	$V_{OL}$	$V_I = V_{IH} \text{ or } V_{IL}$	$I_O=20\mu A; V_{CC}=2.0V$	-	0	0.1	V
			$I_O=20\mu A; V_{CC}=4.5V$	-	0	0.1	V
			$I_O=20\mu A; V_{CC}=6.0V$	-	0	0.1	V
			$I_O=4.0mA; V_{CC}=4.5V$	-	0.15	0.26	V
			$I_O=5.2mA; V_{CC}=6.0V$	-	0.16	0.26	V
input leakage current	$I_I$	$V_I=V_{CC} \text{ or } GND; V_{CC}=6.0V$	-	-	$\pm 1.0$	$\mu A$	
supply current	$I_{CC}$	$V_I=V_{CC} \text{ or } GND; I_O=0A; V_{CC}=6.0V$	-	-	8.0	$\mu A$	
input capacitance	$C_I$	-	-	3.5	-	pF	



### 3.3.2、DC Characteristics 2

( $T_{amb}=-40^{\circ}\text{C}$  to  $+85^{\circ}\text{C}$ , voltages are referenced to GND (ground=0V), unless otherwise specified.)

Parameter	Symbol	Conditions	Min.	Typ.	Max.	Unit	
HIGH-level input voltage	$V_{IH}$	$V_{CC}=2.0\text{V}$	1.5	-	-	V	
		$V_{CC}=4.5\text{V}$	3.15	-	-	V	
		$V_{CC}=6.0\text{V}$	4.2	-	-	V	
LOW-level input voltage	$V_{IL}$	$V_{CC}=2.0\text{V}$	-	-	0.5	V	
		$V_{CC}=4.5\text{V}$	-	-	1.35	V	
		$V_{CC}=6.0\text{V}$	-	-	1.8	V	
HIGH-level output voltage	$V_{OH}$	$V_I = V_{IH} \text{ or } V_{IL}$	$I_O=-20\mu\text{A}; V_{CC}=2.0\text{V}$	1.9	-	-	V
			$I_O=-20\mu\text{A}; V_{CC}=4.5\text{V}$	4.4	-	-	V
			$I_O=-20\mu\text{A}; V_{CC}=6.0\text{V}$	5.9	-	-	V
			$I_O=-4.0\text{mA}; V_{CC}=4.5\text{V}$	3.84	-	-	V
			$I_O=-5.2\text{mA}; V_{CC}=6.0\text{V}$	5.34	-	-	V
LOW-level output voltage	$V_{OL}$	$V_I = V_{IH} \text{ or } V_{IL}$	$I_O=20\mu\text{A}; V_{CC}=2.0\text{V}$	-	-	0.1	V
			$I_O=20\mu\text{A}; V_{CC}=4.5\text{V}$	-	-	0.1	V
			$I_O=20\mu\text{A}; V_{CC}=6.0\text{V}$	-	-	0.1	V
			$I_O=4.0\text{mA}; V_{CC}=4.5\text{V}$	-	-	0.33	V
			$I_O=5.2\text{mA}; V_{CC}=6.0\text{V}$	-	-	0.33	V
input leakage current	$I_I$	$V_I=V_{CC} \text{ or } \text{GND}; V_{CC}=6.0\text{V}$	-	-	$\pm 1.0$	$\mu\text{A}$	
supply current	$I_{CC}$	$V_I=V_{CC} \text{ or } \text{GND}; I_O=0\text{A}; V_{CC}=6.0\text{V}$	-	-	80	$\mu\text{A}$	





### 3.3.3、DC Characteristics 3

( $T_{amb}=-40^{\circ}\text{C}$  to  $+125^{\circ}\text{C}$ , voltages are referenced to GND (ground=0V), unless otherwise specified.)

Parameter	Symbol	Conditions	Min.	Typ.	Max.	Unit	
HIGH-level input voltage	$V_{IH}$	$V_{CC}=2.0\text{V}$	1.5	-	-	V	
		$V_{CC}=4.5\text{V}$	3.15	-	-	V	
		$V_{CC}=6.0\text{V}$	4.2	-	-	V	
LOW-level input voltage	$V_{IL}$	$V_{CC}=2.0\text{V}$	-	-	0.5	V	
		$V_{CC}=4.5\text{V}$	-	-	1.35	V	
		$V_{CC}=6.0\text{V}$	-	-	1.8	V	
HIGH-level output voltage	$V_{OH}$	$V_I = V_{IH} \text{ or } V_{IL}$	$I_O=-20\mu\text{A}; V_{CC}=2.0\text{V}$	1.9	-	-	V
			$I_O=-20\mu\text{A}; V_{CC}=4.5\text{V}$	4.4	-	-	V
			$I_O=-20\mu\text{A}; V_{CC}=6.0\text{V}$	5.9	-	-	V
			$I_O=-4.0\text{mA}; V_{CC}=4.5\text{V}$	3.7	-	-	V
			$I_O=-5.2\text{mA}; V_{CC}=6.0\text{V}$	5.2	-	-	V
LOW-level output voltage	$V_{OL}$	$V_I = V_{IH} \text{ or } V_{IL}$	$I_O=20\mu\text{A}; V_{CC}=2.0\text{V}$	-	-	0.1	V
			$I_O=20\mu\text{A}; V_{CC}=4.5\text{V}$	-	-	0.1	V
			$I_O=20\mu\text{A}; V_{CC}=6.0\text{V}$	-	-	0.1	V
			$I_O=4.0\text{mA}; V_{CC}=4.5\text{V}$	-	-	0.4	V
			$I_O=5.2\text{mA}; V_{CC}=6.0\text{V}$	-	-	0.4	V
input leakage current	$I_I$	$V_I=V_{CC} \text{ or } \text{GND}; V_{CC}=6.0\text{V}$	-	-	$\pm 1.0$	$\mu\text{A}$	
supply current	$I_{CC}$	$V_I=V_{CC} \text{ or } \text{GND}; I_O=0\text{A}; V_{CC}=6.0\text{V}$	-	-	160	$\mu\text{A}$	



### 3.3.4、AC Characteristics 1

( $T_{amb}=25^{\circ}C$ ,  $GND=0V$ ;  $t_r=t_f=6ns$ ;  $C_L=50pF$ , unless otherwise specified.)

Parameter	Symbol	Conditions	Min.	Typ.	Max.	Unit	
propagation delay	$t_{pd}$	CIN to S1; see Figure 6	$V_{CC}=2.0V$	-	52	160	ns
			$V_{CC}=4.5V$	-	19	32	ns
			$V_{CC}=5.0V$ ; $C_L=15pF$	-	16	-	ns
			$V_{CC}=6.0V$	-	15	27	ns
		CIN to S2; see Figure 6	$V_{CC}=2.0V$	-	58	180	ns
			$V_{CC}=4.5V$	-	21	36	ns
			$V_{CC}=5.0V$ ; $C_L=15pF$	-	18	-	ns
			$V_{CC}=6.0V$	-	17	31	ns
		CIN to S3; see Figure 6	$V_{CC}=2.0V$	-	63	195	ns
			$V_{CC}=4.5V$	-	23	39	ns
			$V_{CC}=5.0V$ ; $C_L=15pF$	-	20	-	ns
			$V_{CC}=6.0V$	-	18	33	ns
		CIN to S4; see Figure 6	$V_{CC}=2.0V$	-	74	230	ns
			$V_{CC}=4.5V$	-	27	46	ns
			$V_{CC}=5.0V$ ; $C_L=15pF$	-	23	-	ns
			$V_{CC}=6.0V$	-	22	39	ns
		An or Bn to Sn; see Figure 6	$V_{CC}=2.0V$	-	69	210	ns
			$V_{CC}=4.5V$	-	25	42	ns
			$V_{CC}=5.0V$ ; $C_L=15pF$	-	21	-	ns
		CIN to COUT; see Figure 6	$V_{CC}=6.0V$	-	20	36	ns
			$V_{CC}=2.0V$	-	63	195	ns
			$V_{CC}=4.5V$	-	23	39	ns
		An or Bn to COUT; see Figure 6	$V_{CC}=5.0V$ ; $C_L=15pF$	-	20	-	ns
			$V_{CC}=6.0V$	-	18	33	ns
$V_{CC}=2.0V$	-		63	195	ns		
$V_{CC}=4.5V$	-		23	39	ns		
transition time	$t_t$	see Figure 6	$V_{CC}=5.0V$ ; $C_L=15pF$	-	20	-	ns
			$V_{CC}=6.0V$	-	18	33	ns
			$V_{CC}=2.0V$	-	63	195	ns
power dissipation capacitance	$C_{PD}$	$V_I=GND$ to $V_{CC}$	$V_{CC}=4.5V$	-	7	15	ns
			$V_{CC}=6.0V$	-	6	13	ns
				-	88	-	pF

Note:

[1]  $t_{pd}$  is the same as  $t_{PLH}$  and  $t_{PHL}$ .

[2]  $t_t$  is the same as  $t_{THL}$  and  $t_{TLH}$ .

[3]  $C_{PD}$  is used to determine the dynamic power dissipation ( $P_D$  in uW).

$$P_D = C_{PD} \times V_{CC}^2 \times f_i \times N + \sum (C_L \times V_{CC}^2 \times f_o) \text{ where:}$$

$f_i$ =input frequency in MHz;



灵星芯微 芯片经营

深圳市灵星芯微电子科技有限公司

Shenzhen Lingxing Microelectronics Technology Co., Ltd.

Tab: 835-12

rev:B3

Number:SN74LS283-AX-LJ-A051EN

$f_o$ =output frequency in MHz;

$C_L$ =output load capacitance in pF;

$V_{CC}$ =supply voltage in V;

N=number of inputs switching;

$\sum(C_L \times V_{CC}^2 \times f_o)$ =sum of outputs.

Lingxingic



### 3.3.5、AC Characteristics 2

( $T_{amb} = -40^{\circ}\text{C}$  to  $+85^{\circ}\text{C}$ ,  $GND = 0\text{V}$ ;  $t_r = t_f = 6\text{ns}$ ;  $C_L = 50\text{pF}$ , unless otherwise specified.)

Parameter	Symbol	Conditions	Min.	Typ.	Max.	Unit	
propagation delay	$t_{pd}$	CIN to S1; see Figure 6	$V_{CC} = 2.0\text{V}$	-	-	200	ns
			$V_{CC} = 4.5\text{V}$	-	-	40	ns
			$V_{CC} = 6.0\text{V}$	-	-	34	ns
		CIN to S2; see Figure 6	$V_{CC} = 2.0\text{V}$	-	-	225	ns
			$V_{CC} = 4.5\text{V}$	-	-	45	ns
			$V_{CC} = 6.0\text{V}$	-	-	38	ns
		CIN to S3; see Figure 6	$V_{CC} = 2.0\text{V}$	-	-	245	ns
			$V_{CC} = 4.5\text{V}$	-	-	49	ns
			$V_{CC} = 6.0\text{V}$	-	-	42	ns
		CIN to S4; see Figure 6	$V_{CC} = 2.0\text{V}$	-	-	290	ns
			$V_{CC} = 4.5\text{V}$	-	-	58	ns
			$V_{CC} = 6.0\text{V}$	-	-	49	ns
		An or Bn to Sn; see Figure 6	$V_{CC} = 2.0\text{V}$	-	-	265	ns
			$V_{CC} = 4.5\text{V}$	-	-	53	ns
			$V_{CC} = 6.0\text{V}$	-	-	45	ns
		CIN to COUT; see Figure 6	$V_{CC} = 2.0\text{V}$	-	-	245	ns
			$V_{CC} = 4.5\text{V}$	-	-	49	ns
			$V_{CC} = 6.0\text{V}$	-	-	42	ns
An or Bn to COUT; see Figure 6	$V_{CC} = 2.0\text{V}$	-	-	245	ns		
	$V_{CC} = 4.5\text{V}$	-	-	49	ns		
	$V_{CC} = 6.0\text{V}$	-	-	42	ns		
transition time	$t_t$	see Figure 6	$V_{CC} = 2.0\text{V}$	-	-	95	ns
			$V_{CC} = 4.5\text{V}$	-	-	19	ns
			$V_{CC} = 6.0\text{V}$	-	-	16	ns

Note:

[1]  $t_{pd}$  is the same as  $t_{PLH}$  and  $t_{PHL}$ .

[2]  $t_t$  is the same as  $t_{THL}$  and  $t_{TLH}$ .



### 3.3.6、AC Characteristics 3

( $T_{amb} = -40^{\circ}\text{C}$  to  $+125^{\circ}\text{C}$ ,  $GND = 0\text{V}$ ;  $t_r = t_f = 6\text{ns}$ ;  $C_L = 50\text{pF}$ , unless otherwise specified.)

Parameter	Symbol	Conditions	Min.	Typ.	Max.	Unit	
<b>SN74LS283</b>							
propagation delay	$t_{pd}$	CIN to S1; see Figure 6	$V_{CC} = 2.0\text{V}$	-	-	240	ns
			$V_{CC} = 4.5\text{V}$	-	-	48	ns
			$V_{CC} = 6.0\text{V}$	-	-	41	ns
		CIN to S2; see Figure 6	$V_{CC} = 2.0\text{V}$	-	-	270	ns
			$V_{CC} = 4.5\text{V}$	-	-	54	ns
			$V_{CC} = 6.0\text{V}$	-	-	46	ns
		CIN to S3; see Figure 6	$V_{CC} = 2.0\text{V}$	-	-	295	ns
			$V_{CC} = 4.5\text{V}$	-	-	59	ns
			$V_{CC} = 6.0\text{V}$	-	-	50	ns
		CIN to S4; see Figure 6	$V_{CC} = 2.0\text{V}$	-	-	345	ns
			$V_{CC} = 4.5\text{V}$	-	-	69	ns
			$V_{CC} = 6.0\text{V}$	-	-	59	ns
		An or Bn to Sn; see Figure 6	$V_{CC} = 2.0\text{V}$	-	-	315	ns
			$V_{CC} = 4.5\text{V}$	-	-	63	ns
			$V_{CC} = 6.0\text{V}$	-	-	54	ns
		CIN to COUT; see Figure 6	$V_{CC} = 2.0\text{V}$	-	-	295	ns
			$V_{CC} = 4.5\text{V}$	-	-	59	ns
			$V_{CC} = 6.0\text{V}$	-	-	50	ns
An or Bn to COUT; see Figure 6	$V_{CC} = 2.0\text{V}$	-	-	295	ns		
	$V_{CC} = 4.5\text{V}$	-	-	59	ns		
	$V_{CC} = 6.0\text{V}$	-	-	50	ns		
transition time	$t_t$	see Figure 6	$V_{CC} = 2.0\text{V}$	-	-	110	ns
			$V_{CC} = 4.5\text{V}$	-	-	22	ns
			$V_{CC} = 6.0\text{V}$	-	-	19	ns

Note:

[1]  $t_{pd}$  is the same as  $t_{PLH}$  and  $t_{PHL}$ .

[2]  $t_t$  is the same as  $t_{THL}$  and  $t_{TLH}$ .

## 4、Testing Circuit

### 4.1、AC Testing Circuit

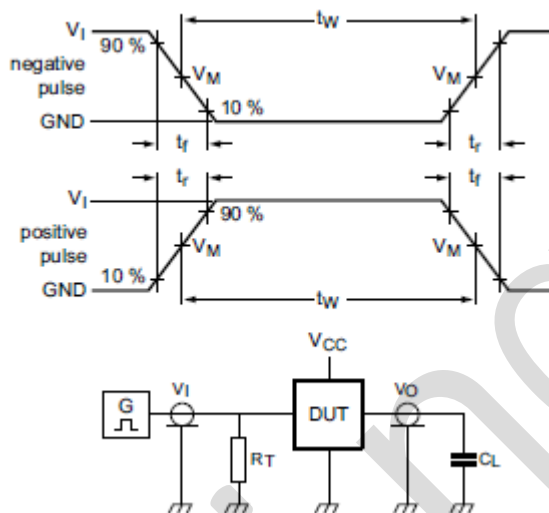

Figure 5. Test circuit for measuring switching times

Definitions for test circuit:

$C_L$ =Load capacitance including jig and probe capacitance.

$R_T$ =Termination resistance should be equal to the output impedance  $Z_o$  of the pulse generator.

### 4.2、AC Testing Waveforms

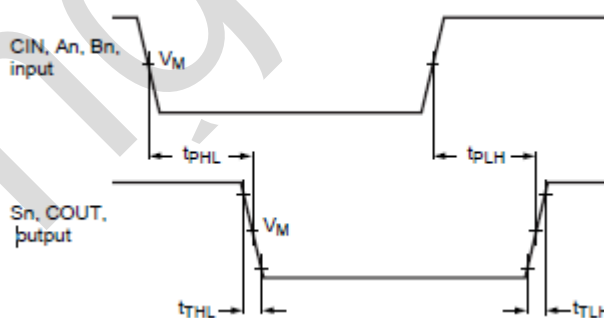

Figure 6. Waveforms showing the inputs (CIN, An and Bn) to the outputs (Sn and COUT) propagation delays and the output transition times

### 4.3、Measurement Points

Input	Output
$V_M$	$V_M$
$0.5 \times V_{CC}$	$0.5 \times V_{CC}$



#### 4.4、Test Data

Input		Load	Test
$V_I$	$t_r, t_f$	$C_L$	
$V_{CC}$	6ns	15pF, 50pF	$t_{PLH}, t_{PHL}$



## 5、Package Information

### 5.1、DIP16

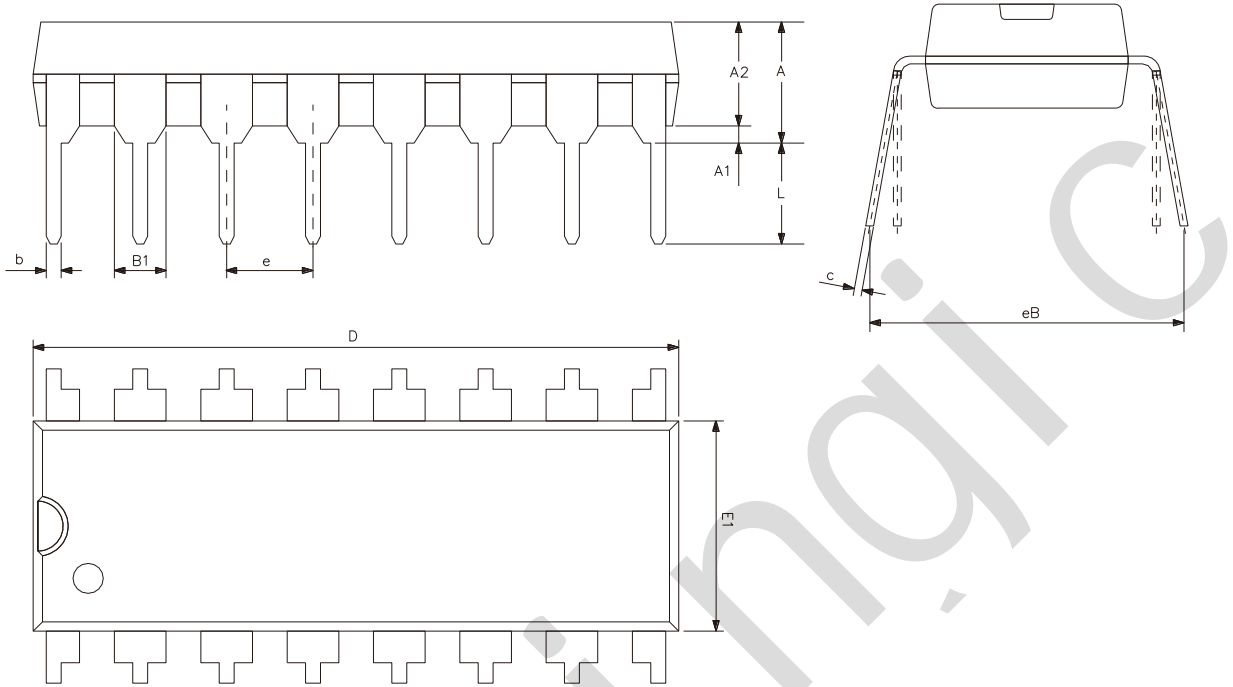

Symbol	Dimensions (mm)	
	Min.	Max.
A2	3.20	3.60
A1	0.51	-
A	3.60	5.33
L	3.00	3.60
b	0.36	0.56
B1	1.52	
D	18.80	19.94
E1	6.20	6.60
e	2.54	
c	0.20	0.36
eB	7.62	9.30





### 5.2、SOP16

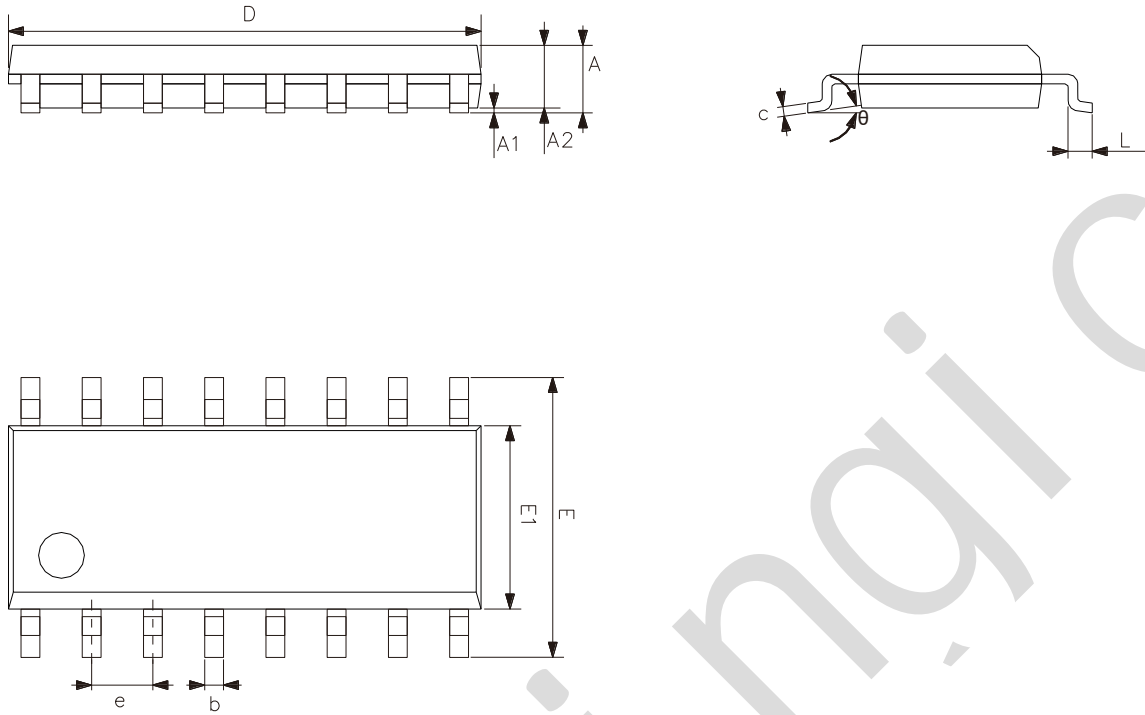

Symbol	Dimensions (mm)	
	Min.	Max.
A	1.35	1.80
A1	0.10	0.25
A2	1.25	1.55
b	0.33	0.51
c	0.19	0.25
D	9.50	10.10
E	5.80	6.30
E1	3.70	4.10
e	1.27	
L	0.35	0.89
θ	0°	8°



## 6、 Statements And Notes

### 6.1、 The name and content of Hazardous substances or Elements in the product

Part name	Hazardous substances or Elements									
	Lead and lead compounds	Mercury and mercury compounds	Cadmium and cadmium compounds	Hexavalent chromium compounds	Polybrominated biphenyls	Polybrominated biphenyl ethers	Dibutyl phthalate	Butylbenzyl phthalate	Di-2-ethylhexyl phthalate	Diisobutyl phthalate
Lead frame	○	○	○	○	○	○	○	○	○	○
Plastic resin	○	○	○	○	○	○	○	○	○	○
Chip	○	○	○	○	○	○	○	○	○	○
The lead	○	○	○	○	○	○	○	○	○	○
Plastic sheet installed	○	○	○	○	○	○	○	○	○	○
explanation	○: Indicates that the content of hazardous substances or elements in the detection limit of the following the SJ/T11363-2006 standard. ×: Indicates that the content of hazardous substances or elements exceeding the SJ/T11363-2006 Standard limit requirements.									

### 6.2、 Notion

Recommended carefully reading this information before the use of this product;

The information in this document are subject to change without notice;

This information is using to the reference only, the company is not responsible for any loss;

The company is not responsible for the any infringement of the third party patents or other rights of the responsibility.

## X-ON Electronics

Largest Supplier of Electrical and Electronic Components

*Click to view similar products for [Buffers & Line Drivers](#) category:*

*Click to view products by [lingxingic](#) manufacturer:*

Other Similar products are found below :

[LXV200-024SW](#) [74AUP2G34FW3-7](#) [HEF4043BP](#) [NL17SG125DFT2G](#) [NLU1GT126CMUTCG](#) [CD4041UBE](#) [54FCT240CTDB](#)

[74HCT540N](#) [DS14C88N](#) [070519XB](#) [NL17SZ07P5T5G](#) [74LVC2G17FW4-7](#) [CD4502BE](#) [5962-8982101PA](#) [NL17SH17P5T5G](#)

[74HCT126T14-13](#) [74VHC9126FT\(BJ\)](#) [RHRXH162244K1](#) [74AUP1G34FW5-7](#) [74AUP1G07FW5-7](#) [74LVC1G126FW4-7](#)

[74LVC2G126RA3-7](#) [74LVCE1G125FZ4-7](#) [74AUP1G126FW5-7](#) [54FCT240TLB](#) [74LVCE1G07FZ4-7](#) [NLX3G16DMUTCG](#)

[NLX2G06AMUTCG](#) [LE87100NQCT](#) [LE87285NQC](#) [LE87290YQC](#) [LE87290YQCT](#) [74AUP1G125FW5-7](#) [NLU2G16CMUTCG](#)

[MC74LCX244MN2TWG](#) [NL17SG17P5T5G](#) [NLV74HC125ADR2G](#) [NLVHCT245ADTR2G](#) [NLVVHC1G126DFT2G](#) [EL5623IRZ](#)

[ISL15102AIRZ-T13](#) [ISL1539IRZ-T13](#) [MC100EP17MNG](#) [MC74HCT365ADR2G](#) [MC74LCX244ADTR2G](#) [NL27WZ126US](#) [NL37WZ16US](#)

[NLU1G07MUTCG](#) [NLU2G07MUTCG](#) [NLX3G17BMX1TCG](#)