



# SN74LS90 (LX) Decade and Binary Counters

## Product Specification

### Specification Revision History:

Version	Date	Description
2023-08-A0	2023-08	New
2023-11-A1	2023-11	Parameter modification



# Contents

<b>1、 General Description.....</b>	<b>1</b>
<b>2、 Block Diagram And Pin Description .....</b>	<b>4</b>
2.1、 Block Diagram .....	4
2.2、 Pin Configurations .....	4
2.3、 Pin Description.....	5
2.4、 Function Table .....	5
<b>3、 Electrical Parameter .....</b>	<b>6</b>
3.1、 Absolute Maximum Ratings.....	6
3.2、 Recommended Operating Conditions .....	6
3.3、 Electrical Characteristics.....	7
3.3.1、 DC Characteristics 1 .....	7
3.3.2、 DC Characteristics 2.....	8
3.3.3、 AC Characteristics 1 .....	9
3.3.4、 AC Characteristics 2.....	10
<b>4、 Testing Circuit .....</b>	<b>11</b>
4.1、 AC Testing Circuit.....	11
4.2、 Test Data .....	11
4.3、 AC Testing Waveforms.....	11
4.4、 Measurement Points .....	12
<b>5、 Package Information .....</b>	<b>13</b>
5.1、 DIP14.....	13
5.2、 SOP14.....	14
5.3、 TSSOP14.....	15
<b>6、 Statements And Notes .....</b>	<b>16</b>
6.1、 The name and content of Hazardous substances or Elements in the product .....	16
6.2、 Notes.....	16



灵星芯微 集成电路

## 1、General Description

The SN74LS90 is a decade and binary counter. Output QA is connected to in CKB for BCD count. Output QD is connected to input CKA for bi-quinary count. In the counting modes, state changes are initiated by the falling edge of the clock.

### Features:

- Temperature range: -40°C to +125°C
- Packaging information: DIP14/SOP14/TSSOP14



**Ordering Information:**

**Tube packing specifications:**

Part number	Packaging form	Marking code	Tube quantity	Boxed tube quantity	Boxed quantity	Notes
SN74LS90N(LX)	DIP14	SN74LS90N	25 PCS/tube	40 tube/box	1000 PCS/box	Dimensions of plastic enclosure: 19.0mm×6.4mm Pin spacing: 2.54mm
SN74LS90D(LX)	SOP14	LS90	50 PCS/tube	200 tube/box	10000 PCS/box	Dimensions of plastic enclosure: 8.7mm×3.9mm Pin spacing: 1.27mm
SN74LS90P(LX)	TSSOP14	LS90	96 PCS/tube	200 tube/box	19200 PCS/box	Dimensions of plastic enclosure: 5.0mm×4.4mm Pin spacing: 0.65mm



灵星芯微 集成电路

**Reel packing specifications:**

Part number	Packaging form	Marking code	Reel quantity	Boxed reel quantity	Notes
SN74LS90DR(LX)	SOP14	LS90	2500 PCS/reel	5000 PCS/box	Dimensions of plastic enclosure: 8.7mm×3.9mm Pin spacing: 1.27mm
SN74LS90PW(LX)	TSSOP14	LS90	5000 PCS/reel	10000 PCS/box	Dimensions of plastic enclosure: 5.0mm×4.4mm Pin spacing: 0.65mm

Note: If the physical information is inconsistent with the ordering information, please refer to the actual product.



## 2、Block Diagram And Pin Description

### 2.1、Block Diagram

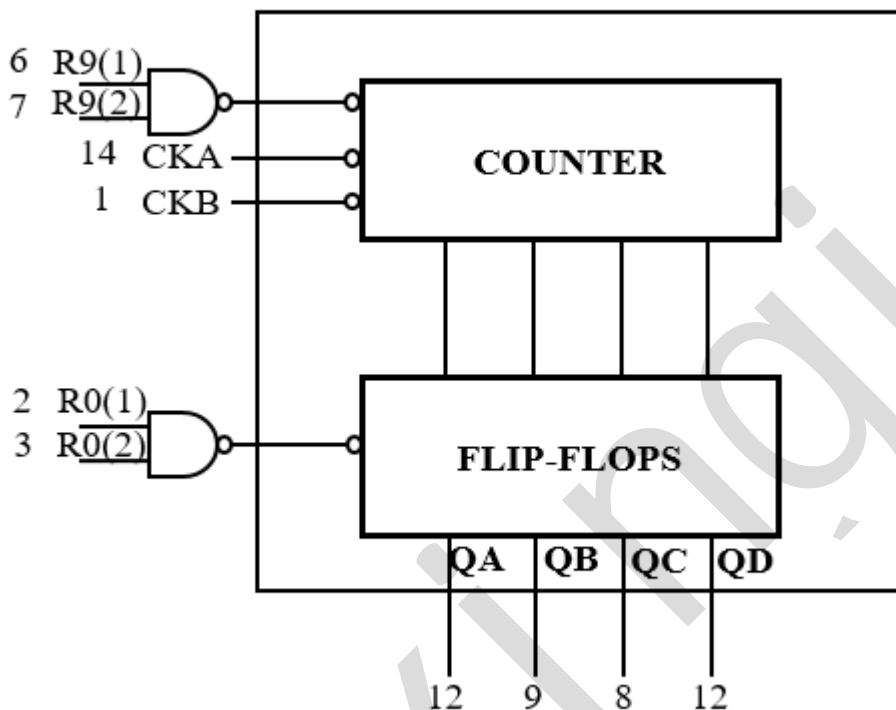
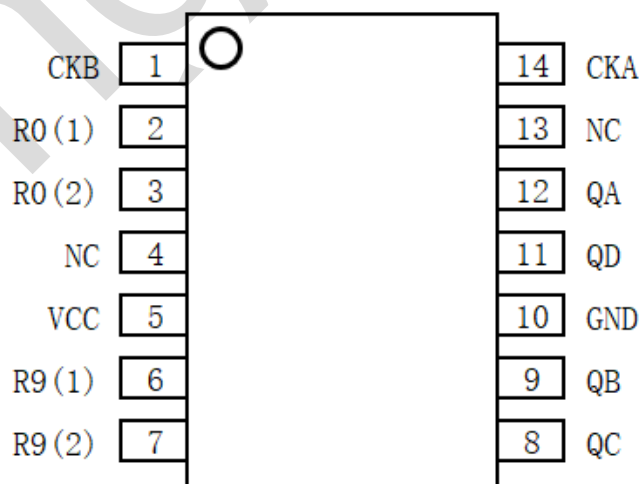

Figure 1. Logic symbol

### 2.2、Pin Configurations





### 2.3、Pin Description

Pin No.	Pin Name	Description
1	CKB	÷ 5 Section Clock Input(Active falling edge)
2	R0(1)	Master reset input
3	R0(2)	Master reset input
4	NC	Not connect
5	VCC	supply voltage
6	R9(1)	Master set input(preset 9)
7	R9(2)	Master set input(preset 9)
8	QC	Output from ÷5
9	QB	Output from ÷5
10	GND	ground (0V)
11	QD	Output from ÷5
12	QA	Output from ÷2
13	NC	Not connect
14	CKA	÷ 2 Section Clock Input(Active falling edge)

### 2.4、Function Table

BCD COUNT SEQUENCE(See Note A)				
COUNT	Outputs			
	QD	QC	QB	QA
0	L	L	L	L
1	L	L	L	H
2	L	L	H	L
3	L	L	H	H
4	L	H	L	L
5	L	H	L	H
6	L	H	H	L
7	L	H	H	H
8	H	L	L	L
9	H	L	L	H

BI-QUINARY(See Note B)				
COUNT	Outputs			
	QA	QD	QC	QB
0	L	L	L	L
1	L	L	L	H
2	L	L	H	L
3	L	L	H	H
4	L	H	L	L
5	H	L	L	L



6	H	L	L	H
7	H	L	H	L
8	H	L	H	H
9	H	H	L	L

RESET/COUNT FUNCTION TABLE							
RESET INPUT				Output			
R0(1)	R0(2)	R9(1)	R9(2)	QD	QC	QB	QA
H	H	L	X	L	L	L	L
H	H	X	L	L	L	L	L
X	X	H	H	H	L	L	H
X	L	X	L	COUNT			
L	X	L	X	COUNT			
L	X	X	L	COUNT			
X	L	L	X	COUNT			

Note:

H=HIGH voltage level; L=LOW voltage level; X=don't care

A:Output QA is connected to input CKB for BCD count

B:Output QD is connected to input CKA for bi-quinary count.

### 3、Electrical Parameter

#### 3.1、Absolute Maximum Ratings

(Voltages are referenced to GND (ground=0V), unless otherwise specified.)

Parameter	Symbol	Conditions	Min.	Max.	Unit
supply voltage	$V_{CC}$	-	-0.5	+7	V
supply current	$I_{CC}$	-	-	50	mA
ground current	$I_{GND}$	-	-50	-	mA
input clamping current	$I_{IK}$	$V_I < -0.5V$ or $V_I > V_{CC}+0.5V$	-	$\pm 20$	mA
output clamping current	$I_{OK}$	$V_O < -0.5V$ or $V_O > V_{CC}+0.5V$	-	$\pm 20$	mA
output current	$I_O$	$-0.5V < V_O < V_{CC}+0.5V$	-	$\pm 25$	mA
storage temperature	$T_{stg}$	-	-65	+150	$^{\circ}C$
soldering temperature	$T_L$	10s	DIP		$^{\circ}C$
			SOP/TSSOP		

#### 3.2、Recommended Operating Conditions

Parameter	Symbol	Conditions	Min.	Typ.	Max.	Unit
supply voltage	$V_{CC}$	-	2.0	5.0	6.0	V
input voltage	$V_I$	-	0	-	$V_{CC}$	V
output voltage	$V_O$	-	0	-	$V_{CC}$	V
ambient	$T_{amb}$	-	-40	-	+125	$^{\circ}C$





temperature						
-------------	--	--	--	--	--	--

### 3.3、Electrical Characteristics

#### 3.3.1、DC Characteristics 1

( $T_{amb} = -40^{\circ}\text{C}$  to  $+85^{\circ}\text{C}$ , voltages are referenced to GND (ground=0V), unless otherwise specified.)

Parameter	Symbol	V <sub>CC</sub>	Conditions	Min.	Typ.	Max.	Unit
HIGH-level input voltage	V <sub>IH</sub>	2.0V	-	1.5	1.2	-	V
		4.5V	-	3.15	2.4	-	V
		6.0V	-	4.2	3.2	-	V
LOW-level input voltage	V <sub>IL</sub>	2.0V	-	-	0.8	0.5	V
		4.5V	-	-	2.1	1.35	V
		6.0V	-	-	2.8	1.8	V
HIGH-level output voltage	V <sub>OH</sub>	2.0V	I <sub>O</sub> =-20uA	1.9	2.0	-	V
		4.5V	I <sub>O</sub> =-20uA	4.4	4.5	-	V
		6.0V	I <sub>O</sub> =-20uA	5.9	6.0	-	V
		4.5V	I <sub>O</sub> =-4.0mA	3.84	4.32	-	V
		6.0V	I <sub>O</sub> =-5.2mA	5.34	5.81	-	V
LOW-level output voltage	V <sub>OL</sub>	2.0V	I <sub>O</sub> =20uA	-	0	0.1	V
		4.5V	I <sub>O</sub> =20uA	-	0	0.1	V
		6.0V	I <sub>O</sub> =20uA	-	0	0.1	V
		4.5V	I <sub>O</sub> =4.0mA	-	0.15	0.33	V
		6.0V	I <sub>O</sub> =5.2mA	-	0.16	0.33	V
input leakage current	I <sub>I</sub>	6.0V	V <sub>I</sub> =V <sub>CC</sub> or GND	-	-	±1	uA
supply current	I <sub>CC</sub>	6.0V	V <sub>I</sub> =V <sub>CC</sub> or GND; I <sub>O</sub> =0A	-	-	80	uA



### 3.3.2、DC Characteristics 2

( $T_{amb} = -40^{\circ}\text{C}$  to  $+125^{\circ}\text{C}$ , voltages are referenced to GND (ground=0V), unless otherwise specified.)

Parameter	Symbol	V <sub>CC</sub>	Conditions	Min.	Typ.	Max.	Unit
HIGH-level input voltage	V <sub>IH</sub>	2.0V	-	1.5	-	-	V
		4.5V	-	3.15	-	-	V
		6.0V	-	4.2	-	-	V
LOW-level input voltage	V <sub>IL</sub>	2.0V	-	-	-	0.5	V
		4.5V	-	-	-	1.35	V
		6.0V	-	-	-	1.8	V
HIGH-level output voltage	V <sub>OH</sub>	2.0V	I <sub>O</sub> =-20uA	1.9	-	-	V
		4.5V	I <sub>O</sub> =-20uA	4.4	-	-	V
		6.0V	I <sub>O</sub> =-20uA	5.9	-	-	V
		4.5V	I <sub>O</sub> =-4.0mA	3.7	-	-	V
		6.0V	I <sub>O</sub> =-5.2mA	5.2	-	-	V
LOW-level output voltage	V <sub>OL</sub>	2.0V	I <sub>O</sub> =20uA	-	-	0.1	V
		4.5V	I <sub>O</sub> =20uA	-	-	0.1	V
		6.0V	I <sub>O</sub> =20uA	-	-	0.1	V
		4.5V	I <sub>O</sub> =4.0mA	-	-	0.4	V
		6.0V	I <sub>O</sub> =5.2mA	-	-	0.4	V
input leakage current	I <sub>I</sub>	6.0V	V <sub>I</sub> =V <sub>CC</sub> or GND	-	-	±1	uA
supply current	I <sub>CC</sub>	6.0V	V <sub>I</sub> =V <sub>CC</sub> or GND; I <sub>O</sub> =0A	-	-	160	uA



### 3.3.3、AC Characteristics 1

( $T_{amb} = -40^{\circ}\text{C}$  to  $+85^{\circ}\text{C}$ , voltages are referenced to GND (ground=0V), unless otherwise specified.)

Parameter	Symbol	V <sub>CC</sub>	Conditions		Min.	Typ.	Max.	Unit
LOW to HIGH propagation delay	t <sub>PLH</sub>	5.0V	C <sub>L</sub> =15pF	CKn to Qn see Figure 4	-	-	48	ns
		5.0V	C <sub>L</sub> =15pF	Set-to-9 to QA QD see Figure 4	-	-	30	ns
HIGH to LOW propagation delay	t <sub>PHL</sub>	5.0V	C <sub>L</sub> =15pF	CKn to Qn see Figure 4	-	-	50	ns
		5.0V	C <sub>L</sub> =15pF	Set-to-0 to ANY see Figure 4	-	-	40	ns
		5.0V	C <sub>L</sub> =15pF	Set-to-9 to QB QC see Figure 4	-	-	40	ns
Maximum frequency	f <sub>max</sub>	5.0V	C <sub>L</sub> =15pF	CKA to QA see Figure 4	32	-	-	MHZ
		5.0V	C <sub>L</sub> =15pF	CKB to QB see Figure 4	16	-	-	MHZ



### 3.3.4、AC Characteristics 2

( $T_{amb} = -40^{\circ}\text{C}$  to  $+125^{\circ}\text{C}$ , voltages are referenced to GND (ground=0V), unless otherwise specified.)

Parameter	Symbol	$V_{CC}$	Conditions		Min.	Typ.	Max.	Unit
LOW to HIGH propagation delay	$t_{PLH}$	5.0V	$C_L=15\text{pF}$	CKn to Qn see Figure 4	-	-	57.6	ns
		5.0V	$C_L=15\text{pF}$	Set-to-9 to QA QD see Figure 4	-	-	36	ns
HIGH to LOW propagation delay	$t_{PHL}$	5.0V	$C_L=15\text{pF}$	CKn to Qn see Figure 4	-	-	60	ns
		5.0V	$C_L=15\text{pF}$	Set-to-0 to ANY see Figure 4	-	-	48	ns
		5.0V	$C_L=15\text{pF}$	Set-to-9 to QB QC see Figure 4	-	-	48	ns
Maximum frequency	$f_{max}$	5.0V	$C_L=15\text{pF}$	CKA to QA see Figure 4	26.7	-	-	MHZ
		5.0V	$C_L=15\text{pF}$	CKB to QB see Figure 4	13.3	-	-	MHZ

#### 4、Testing Circuit

##### 4.1、AC Testing Circuit

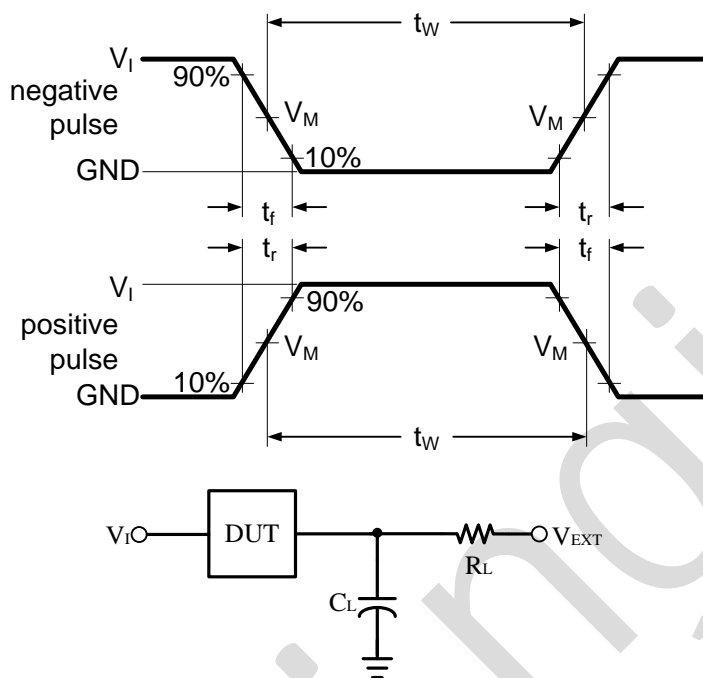

Figure 3. Test circuit for measuring switching times

$C_L$  includes probe and jig capacitance.

##### 4.2、Test Data

Input		Load		$V_{EXT}$		
$V_I$	$t_r = t_f$	$C_L$	$R_L$	$t_{PLH}/t_{PHL}$	$t_{PLZ}/t_{PZL}$	$t_{PHZ}/t_{PZH}$
$V_{CC}$	3.0ns	15pF	2K $\Omega$	Open	$V_{CC}$	GND

##### 4.3、AC Testing Waveforms

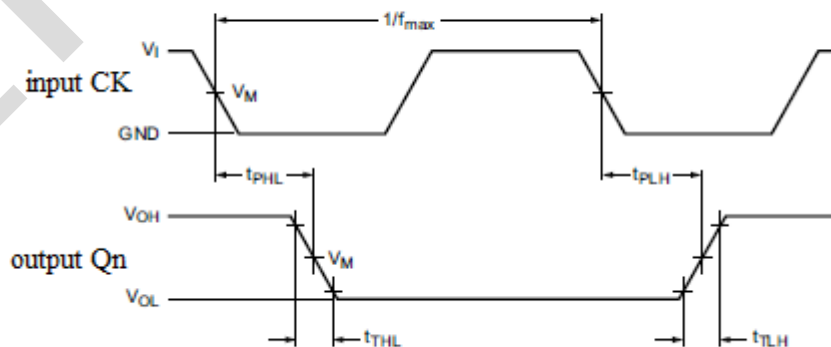

Figure 4. Propagation delay



#### 4.4、Measurement Points

Input	Output
$V_M$	$V_M$
$0.5 \times V_{CC}$	$0.5 \times V_{CC}$



## 5、Package Information

### 5.1、DIP14

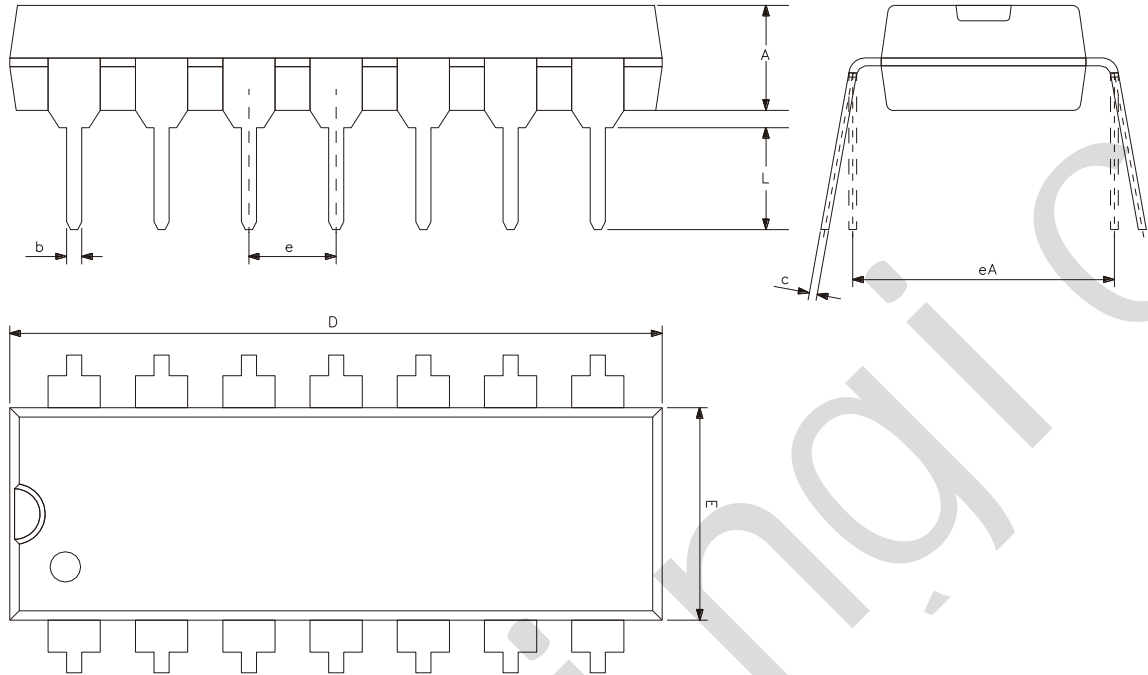

Symbol	Dimensions (mm)	
	Min.	Max.
A	3.05	3.60
b	0.33	0.56
c	0.20	0.36
D	18.80	19.40
E	6.20	6.60
e	2.54	
eA	7.62	10.90
L	2.92	-



## 5.2、SOP14

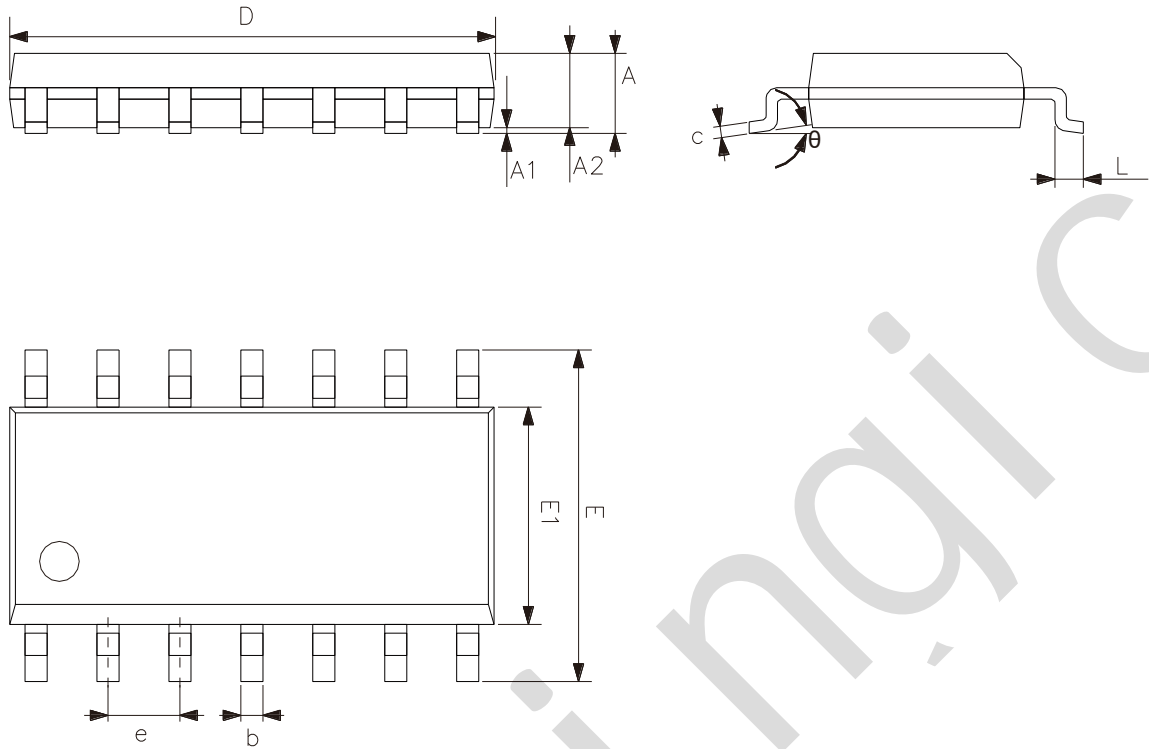

Symbol	Dimensions (mm)	
	Min.	Max.
A	1.50	1.75
A1	0.05	0.25
A2	1.30	-
b	0.33	0.50
c	0.19	0.25
D	8.43	8.76
E	5.80	6.25
E1	3.75	4.00
e	1.27	
L	0.40	0.89
$\theta$	0°	8°





### 5.3、TSSOP14

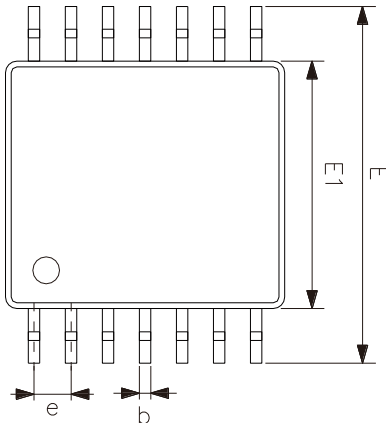
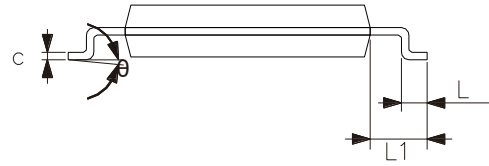
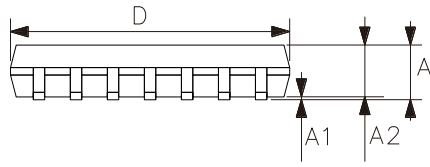

Symbol	Dimensions (mm)	
	Min.	Max.
A	-	1.20
A1	0.05	0.15
A2	0.80	1.05
b	0.19	0.30
c	0.09	0.20
D	4.90	5.10
E1	4.30	4.50
E	6.20	6.60
e	0.65	
L	0.45	0.75
L1	1.00	
$\theta$	0°	8°



## 6、 Statements And Notes

### 6.1、 The name and content of Hazardous substances or Elements in the product

Part name	Hazardous substances or Elements									
	Lead and lead compounds	Mercury and mercury compounds	Cadmium and cadmium compounds	Hexavalent chromium compounds	Polybrominated biphenyls	Polybrominated biphenyl ethers	Dibutyl phthalate	Butylbenzyl phthalate	Di-2-ethylhexyl phthalate	Diisobutyl phthalate
Lead frame	○	○	○	○	○	○	○	○	○	○
Plastic resin	○	○	○	○	○	○	○	○	○	○
Chip	○	○	○	○	○	○	○	○	○	○
The lead	○	○	○	○	○	○	○	○	○	○
Plastic sheet installed	○	○	○	○	○	○	○	○	○	○
explanation	○: Indicates that the content of hazardous substances or elements in the detection limit of the following the SJ/T11363-2006 standard. ×: Indicates that the content of hazardous substances or elements exceeding the SJ/T11363-2006 Standard limit requirements.									

### 6.2、 Notes

We recommend you to read this chapter carefully before using this product.

The information in this chapter is provided for reference only and Lingxing disclaims any express or implied warranties, including but not limited to applicability, special application or non-infringement of third party rights.

This product is not suitable for critical equipment such as life-saving, life-sustaining or safety equipment. It is also not suitable for applications that may result in personal injury, death, or serious property or environmental damage due to product malfunction or failure. Lingxing will not be liable for any damages incurred by the customers at their own risk for such applications.

The customer is responsible for conducting all necessary tests Lingxing's application to avoid failure in the application or the application of the customer's third party users. Lingxing does not accept any liability.

The Company reserves the right to change or improve the information published in this chapter at any time. The information in this chapter are subject to change without notice. We recommend the customer to consult our sales staff before purchasing.

Please obtain related materials form Lingxing's regular channels and we are not responsible for its content if it is provided by sources other than our company.

In case of any conflict between the Chinese and English version, the version is subject to the Chinese one.

## X-ON Electronics

Largest Supplier of Electrical and Electronic Components

*Click to view similar products for [Counter ICs](#) category:*

*Click to view products by [lingxingic](#) manufacturer:*

Other Similar products are found below :

[CD4018BE](#) [CD4033BE](#) [CD4060BE](#) [CD4040BE](#) [NLV14040BDR2G](#) [RFDIP1607ALM9T21](#) [RFDIP1606L708D1T](#) [RFTIP2510T12A8Q1C](#)  
[74HC161DT](#) [CD4028BM/TR](#) [CD4060DM/TR](#) [CD4022BE](#) [CD4060DMT/TR](#) [CD4020BE](#) [CD4060BMT/TR](#) [74HC192M/TR](#)  
[CD4020BMT/TR](#) [CD4017CMT/TR](#) [74HC193M/TR](#) [CD4017CM/TR](#) [AiP74HC193SA16.TB](#) [CD4518BM/TR](#) [CD4060TA16.TB](#) [CD4060DE](#)  
[CD4017CN](#) [CD4017BMT/TR](#) [U74HC4060G-S16-R](#) [CD4017SA.TB](#) [XD74LS160](#) [CD4017BM-MS](#) [CD4022BM/TR](#) [CD4022BMT/TR](#)  
[CD4028BDRG](#) [CD4060BDRG](#) [CD4017DA.TB](#) [CD4520BDRG](#) [CD4520BM\(LX\)](#) [CD4518BM\(LX\)](#) [SN74HC393DR\(LX\)](#) [SN74HC393N\(LX\)](#)  
[CD4060BM\(LX\)](#) [CD4060BE\(LX\)](#) [CD4518BE\(LX\)](#) [CD4520BE\(LX\)](#) [SN74HC192N\(XBLW\)](#) [CD4040BM\(LX\)](#) [CD4026BM\(LX\)](#)  
[CD40103BDR\(LX\)](#) [SN74LS192DR\(LX\)](#) [SN74HC161DR \(LX\)](#)