



SN74LVC1G32 (LX) Single 2-input Or Gate

Product Specification

Specification Revision History:

Version	Date	Description
2021-05-A1	2021-05	New
2023-04-B1	2023-04	Update the template
2023-10-B2	2023-10	Additional package



Contents

1、 General Description	3
2、 Block Diagram And Pin Description	4
2.1、 Block Diagram	4
2.2、 Pin Configurations	5
2.3、 Pin Description.....	5
2.4、 Function Table	6
3、 Electrical Parameter	6
3.1、 Absolute Maximum Ratings.....	6
3.2、 Recommended Operating Conditions	6
3.3、 Electrical Characteristics.....	7
3.3.1、 DC Characteristics 1	7
3.3.2、 DC Characteristics 2.....	8
3.3.3、 AC Characteristics 1	9
3.3.4、 AC Characteristics 2.....	9
4、 Testing Circuit	10
4.1、 AC Testing Circuit.....	10
4.2、 AC Testing Waveforms.....	10
4.3、 Measurement Points	10
4.4、 Test Data	10
5、 Package Information	11
5.1、 SOT23-5	11
5.2、 SOT353.....	12
5.3、 DFN4	13
5.4、 XSON6(1*1*0.45-0.35)	14
6、 Statements	16
6.1、 The name and content of Hazardous substances or Elements in the product	16



1、General Description

The SN74LVC1G32 provides one 2-input OR function.

Inputs can be driven from either 3.3V or 5V devices. This feature allows the use of these devices as translators in mixed 3.3V and 5V applications.

Features:

- Wide supply voltage range from 1.65V to 5.5V
- $\pm 24\text{mA}$ output drive ($V_{CC}=3.0\text{V}$)
- CMOS low power consumption
- Input accepts voltages up to 5V
- Specified from -40°C to $+125^{\circ}\text{C}$
- Packaging information: SOT23-5/SOT353/DFN4/XSON6

Ordering Information:

Reel packing specifications:

Part number	Packaging form	Marking code	Reel quantity	Boxed reel quantity	Notes
SN74LVC1G32DB (LX)	SOT23-5	ALXX	3000 PCS/reel	30000 PCS/box	Dimensions of plastic enclosure: 2.9mm×1.6mm Pin spacing: 0.95mm
SN74LVC1G32DC (LX)	SOT353	ALXX	3000 PCS/reel	30000 PCS/box	Dimensions of plastic enclosure: 2.1mm×1.3mm Pin spacing: 0.65mm
SN74LVC1G32DP (LX)	DFN4	ALXX	12000 PCS/reel	120000 PCS/box	Dimensions of plastic enclosure: 0.8mm×0.8mm Pin spacing: 0.5mm
SN74LVC1G32DS (LX)	XSON6	ALXX	5000 PCS/reel	25000 PCS/box	Dimensions of plastic enclosure: 1.0mm×1.0mm Pin spacing: :0.35mm

Note 1: "XX" refers to variable content, meaning year and package batch serial number.

Note 2: If the physical information is inconsistent with the ordering information, please refer to the actual product.



2、Block Diagram And Pin Description

2.1、Block Diagram

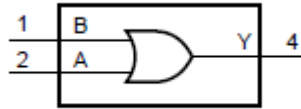

Figure 1. Logic symbol

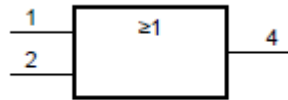

Figure 2. IEC logic symbol

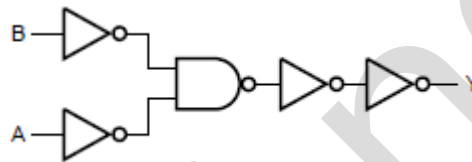
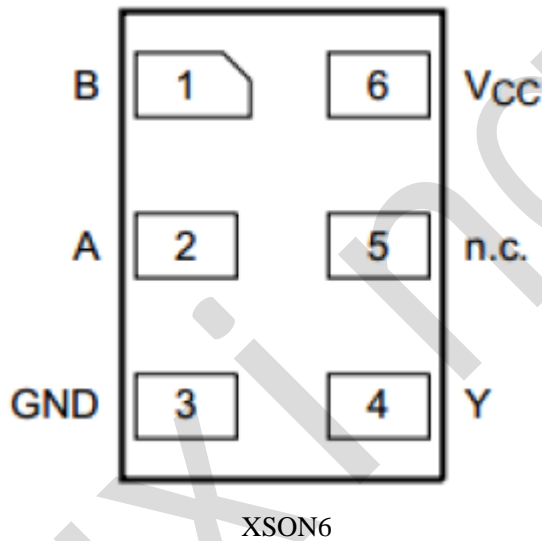
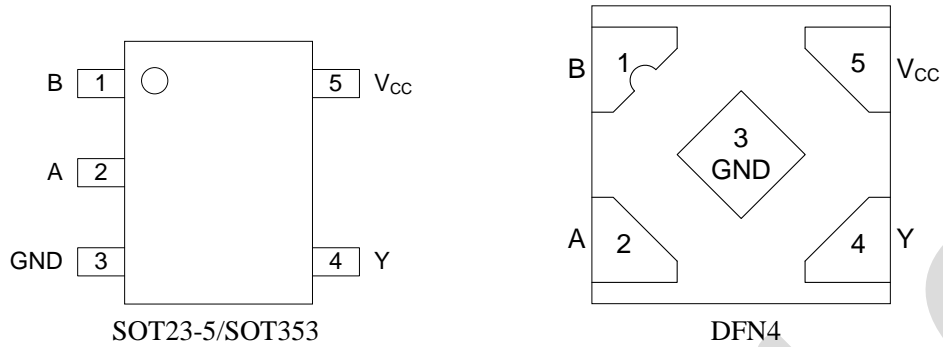

Figure 3. Logic diagram



2.2、Pin Configurations



2.3、Pin Description

Pin No. SOT23-5/SO T353/DFN4	Pin No. XSON6	Pin Name	Description
1	1	B	data input
2	2	A	data input
3	3	GND	ground (0V)
4	4	Y	data output
-	5	n.c.	not connected
5	6	Vcc	supply voltage



2.4、Function Table

Input		Output
A	B	Y
L	L	L
L	H	H
H	L	H
H	H	H

Note: H=HIGH voltage level; L=LOW voltage level.

3、Electrical Parameter

3.1、Absolute Maximum Ratings

(Voltages are referenced to GND (ground=0V), unless otherwise specified.)

Parameter	Symbol	Conditions	Min.	Max.	Unit
supply voltage	V_{CC}	-	-0.5	+6.5	V
input voltage	V_I	-	-0.5	+6.5	V
output voltage	V_O	Active mode	-0.5	$V_{CC}+0.5$	V
		Power-down mode; $V_{CC}=0V$	-0.5	+6.5	V
input clamping current	I_{IK}	$V_I < 0V$	-50	-	mA
output clamping current	I_{OK}	$V_O > V_{CC}$ or $V_O < 0V$	-	± 50	mA
output current	I_O	$V_O=0V$ to V_{CC}	-	± 50	mA
supply current	I_{CC}	-	-	100	mA
ground current	I_{GND}	-	-100	-	mA
storage temperature	T_{stg}	-	-65	+150	°C
total power dissipation	P_{tot}	-	-	250	mW
soldering temperature	T_L	10s	260		°C

3.2、Recommended Operating Conditions

Parameter	Symbol	Conditions	Min.	Typ.	Max.	Unit
supply voltage	V_{CC}	-	1.65	-	5.5	V
input voltage	V_I	-	0	-	5.5	V
output voltage	V_O	Active mode	0	-	V_{CC}	V
		Power-down mode; $V_{CC}=0V$	0	-	5.5	V
ambient temperature	T_{amb}	-	-40	-	+125	°C



3.3、Electrical Characteristics

3.3.1、DC Characteristics 1

($T_{amb}=-40^{\circ}\text{C}$ to $+85^{\circ}\text{C}$, voltages are referenced to GND (ground=0V), unless otherwise specified.)

Parameter	Symbol	Conditions	Min.	Typ.	Max.	Unit	
HIGH-level input voltage	V_{IH}	$V_{CC}=1.65\text{V}$ to 1.95V	$0.65 \times V_{CC}$	-	-	V	
		$V_{CC}=2.3\text{V}$ to 2.7V	1.7	-	-	V	
		$V_{CC}=2.7\text{V}$ to 3.6V	2.0	-	-	V	
		$V_{CC}=4.5\text{V}$ to 5.5V	$0.7 \times V_{CC}$	-	-	V	
LOW-level input voltage	V_{IL}	$V_{CC}=1.65\text{V}$ to 1.95V	-	-	$0.35 \times V_{CC}$	V	
		$V_{CC}=2.3\text{V}$ to 2.7V	-	-	0.7	V	
		$V_{CC}=2.7\text{V}$ to 3.6V	-	-	0.8	V	
		$V_{CC}=4.5\text{V}$ to 5.5V	-	-	$0.3 \times V_{CC}$	V	
HIGH-level output voltage	V_{OH}	$V_I = V_{IH}$ or V_{IL}	$I_O=-100\mu\text{A}$; $V_{CC}=1.65\text{V}$ to 5.5V	$V_{CC} - 0.1$	-	-	V
			$I_O=-4\text{mA}$; $V_{CC}=1.65\text{V}$	1.2	-	-	V
			$I_O=-8\text{mA}$; $V_{CC}=2.3\text{V}$	1.9	-	-	V
			$I_O=-12\text{mA}$; $V_{CC}=2.7\text{V}$	2.2	-	-	V
			$I_O=-24\text{mA}$; $V_{CC}=3.0\text{V}$	2.3	-	-	V
			$I_O=-32\text{mA}$; $V_{CC}=4.5\text{V}$	3.8	-	-	V
LOW-level output voltage	V_{OL}	$V_I = V_{IH}$ or V_{IL}	$I_O=100\mu\text{A}$; $V_{CC}=1.65\text{V}$ to 5.5V	-	-	0.10	V
			$I_O=4\text{mA}$; $V_{CC}=1.65\text{V}$	-	-	0.45	V
			$I_O=8\text{mA}$; $V_{CC}=2.3\text{V}$	-	-	0.30	V
			$I_O=12\text{mA}$; $V_{CC}=2.7\text{V}$	-	-	0.40	V
			$I_O=24\text{mA}$; $V_{CC}=3.0\text{V}$	-	-	0.55	V
			$I_O=32\text{mA}$; $V_{CC}=4.5\text{V}$	-	-	0.55	V
input leakage current	I_I	$V_I=5.5\text{V}$ or GND; $V_{CC}=0\text{V}$ to 5.5V	-	-	± 1	μA	
power-off leakage current	I_{OFF}	V_I or $V_O=5.5\text{V}$; $V_{CC}=0\text{V}$	-	-	± 2	μA	
supply current	I_{CC}	$V_I=5.5\text{V}$ or GND; $I_O=0\text{A}$; $V_{CC}=1.65\text{V}$ to 5.5V	-	-	4	μA	
additional supply current	ΔI_{CC}	per pin; $V_I=V_{CC}-0.6\text{V}$; $I_O=0\text{A}$; $V_{CC}=2.3\text{V}$ to 5.5V	-	-	500	μA	
input capacitance	C_I	$V_{CC}=3.3\text{V}$; $V_I=\text{GND}$ to V_{CC}	-	5	-	pF	

Note: All typical values are measured at $V_{CC}=3.3\text{V}$ and $T_{amb}=25^{\circ}\text{C}$.



3.3.2、DC Characteristics 2

($T_{amb} = -40^{\circ}\text{C}$ to $+125^{\circ}\text{C}$, voltages are referenced to GND (ground=0V), unless otherwise specified.)

Parameter	Symbol	Conditions	Min.	Typ.	Max.	Unit	
HIGH-level input voltage	V_{IH}	$V_{CC}=1.65\text{V}$ to 1.95V	$0.65 \times V_{CC}$	-	-	V	
		$V_{CC}=2.3\text{V}$ to 2.7V	1.7	-	-	V	
		$V_{CC}=2.7\text{V}$ to 3.6V	2.0	-	-	V	
		$V_{CC}=4.5\text{V}$ to 5.5V	$0.7 \times V_{CC}$	-	-	V	
LOW-level input voltage	V_{IL}	$V_{CC}=1.65\text{V}$ to 1.95V	-	-	$0.35 \times V_{CC}$	V	
		$V_{CC}=2.3\text{V}$ to 2.7V	-	-	0.7	V	
		$V_{CC}=2.7\text{V}$ to 3.6V	-	-	0.8	V	
		$V_{CC}=4.5\text{V}$ to 5.5V	-	-	$0.3 \times V_{CC}$	V	
HIGH-level output voltage	V_{OH}	$V_I = V_{IH}$ or V_{IL}	$I_O = -100\mu\text{A}$; $V_{CC}=1.65\text{V}$ to 5.5V	$V_{CC} - 0.1$	-	-	V
			$I_O = -4\text{mA}$; $V_{CC}=1.65\text{V}$	0.95	-	-	V
			$I_O = -8\text{mA}$; $V_{CC}=2.3\text{V}$	1.7	-	-	V
			$I_O = -12\text{mA}$; $V_{CC}=2.7\text{V}$	1.9	-	-	V
			$I_O = -24\text{mA}$; $V_{CC}=3.0\text{V}$	2.0	-	-	V
			$I_O = -32\text{mA}$; $V_{CC}=4.5\text{V}$	3.4	-	-	V
LOW-level output voltage	V_{OL}	$V_I = V_{IH}$ or V_{IL}	$I_O = 100\mu\text{A}$; $V_{CC}=1.65\text{V}$ to 5.5V	-	-	0.10	V
			$I_O = 4\text{mA}$; $V_{CC}=1.65\text{V}$	-	-	0.70	V
			$I_O = 8\text{mA}$; $V_{CC}=2.3\text{V}$	-	-	0.45	V
			$I_O = 12\text{mA}$; $V_{CC}=2.7\text{V}$	-	-	0.60	V
			$I_O = 24\text{mA}$; $V_{CC}=3.0\text{V}$	-	-	0.80	V
			$I_O = 32\text{mA}$; $V_{CC}=4.5\text{V}$	-	-	0.80	V
input leakage current	I_I	$V_I = 5.5\text{V}$ or GND; $V_{CC}=0\text{V}$ to 5.5V	-	-	± 1	μA	
power-off leakage current	I_{OFF}	V_I or $V_O = 5.5\text{V}$; $V_{CC}=0\text{V}$	-	-	± 2	μA	
supply current	I_{CC}	$V_I = 5.5\text{V}$ or GND; $I_O = 0\text{A}$; $V_{CC}=1.65\text{V}$ to 5.5V	-	-	4	μA	
additional supply current	ΔI_{CC}	per pin; $V_I = V_{CC} - 0.6\text{V}$; $I_O = 0\text{A}$; $V_{CC}=2.3\text{V}$ to 5.5V	-	-	500	μA	



3.3.3、AC Characteristics 1

($T_{amb}=-40^{\circ}\text{C}$ to $+85^{\circ}\text{C}$, voltages are referenced to GND (ground=0V), unless otherwise specified.)

Parameter	Symbol	Conditions	Min.	Typ. ^[1]	Max.	Unit	
A, B to Y propagation delay	t_{PHL}	see Figure 5	$V_{CC}=1.65\text{V}$ to 1.95V	-	12.5	18.8	ns
			$V_{CC}=2.3\text{V}$ to 2.7V	-	10.5	15.8	ns
			$V_{CC}=2.7\text{V}$	-	10	15	ns
			$V_{CC}=3.0\text{V}$ to 3.6V	-	9.5	14.3	ns
			$V_{CC}=4.5\text{V}$ to 5.5V	-	9	13.5	ns
A, B to Y propagation delay	t_{PLH}	see Figure 5	$V_{CC}=1.65\text{V}$ to 1.95V	-	14	21	ns
			$V_{CC}=2.3\text{V}$ to 2.7V	-	10	15	ns
			$V_{CC}=2.7\text{V}$	-	9.5	14.3	ns
			$V_{CC}=3.0\text{V}$ to 3.6V	-	8.5	12.8	ns
			$V_{CC}=4.5\text{V}$ to 5.5V	-	7.5	11.3	ns

Note:

[1] Typical values are measured at $T_{amb}=25^{\circ}\text{C}$ and $V_{CC}=1.8\text{V}$, 2.5V , 2.7V , 3.3V and 5.0V respectively.

3.3.4、AC Characteristics 2

($T_{amb}=-40^{\circ}\text{C}$ to $+125^{\circ}\text{C}$, voltages are referenced to GND (ground=0V), unless otherwise specified.)

Parameter	Symbol	Conditions	Min.	Typ.	Max.	Unit	
A, B to Y propagation delay	t_{PHL}	see Figure 5	$V_{CC}=1.65\text{V}$ to 1.95V	-	-	20.8	ns
			$V_{CC}=2.3\text{V}$ to 2.7V	-	-	17.8	ns
			$V_{CC}=2.7\text{V}$	-	-	17	ns
			$V_{CC}=3.0\text{V}$ to 3.6V	-	-	16.3	ns
			$V_{CC}=4.5\text{V}$ to 5.5V	-	-	15.5	ns
A, B to Y propagation delay	t_{PLH}	see Figure 5	$V_{CC}=1.65\text{V}$ to 1.95V	-	-	23	ns
			$V_{CC}=2.3\text{V}$ to 2.7V	-	-	17	ns
			$V_{CC}=2.7\text{V}$	-	-	16.3	ns
			$V_{CC}=3.0\text{V}$ to 3.6V	-	-	14.8	ns
			$V_{CC}=4.5\text{V}$ to 5.5V	-	-	13.3	ns



4、Testing Circuit

4.1、AC Testing Circuit

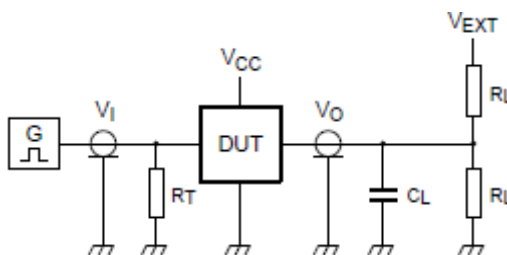

Figure 4. Test circuit for measuring switching times

Definitions for test circuit:

R_L =Load resistance.

C_L =Load capacitance including jig and probe capacitance.

R_T =Termination resistance; should be equal to the output impedance Z_o of the pulse generator.

V_{EXT} =External voltage for measuring switching times.

4.2、AC Testing Waveforms

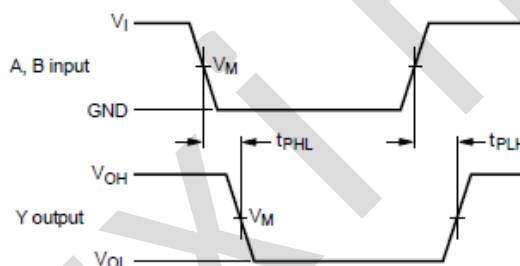

Figure 5. The input A, B to output Y propagation delays

4.3、Measurement Points

Supply voltage	Input	Output
V_{CC}	V_M	V_M
1.65V to 1.95V	$0.5 \times V_{CC}$	$0.5 \times V_{CC}$
2.3V to 2.7V	$0.5 \times V_{CC}$	$0.5 \times V_{CC}$
2.7V	1.5V	1.5V
3.0V to 3.6V	1.5V	1.5V
4.5V to 5.5V	$0.5 \times V_{CC}$	$0.5 \times V_{CC}$

4.4、Test Data

Supply voltage	Input		Load		V_{EXT}
V_{CC}	V_I	$t_r = t_f$	C_L	R_L	t_{PLH}, t_{PHL}
1.65V to 1.95V	V_{CC}	$\leq 3ns$	30pF	1k Ω	open
2.3V to 2.7V	V_{CC}	$\leq 3ns$	30pF	500 Ω	open
2.7V	2.7V	$\leq 3ns$	50pF	500 Ω	open
3.0V to 3.6V	2.7V	$\leq 3ns$	50pF	500 Ω	open
4.5V to 5.5V	V_{CC}	$\leq 3ns$	50pF	500 Ω	open



5、Package Information

5.1、SOT23-5

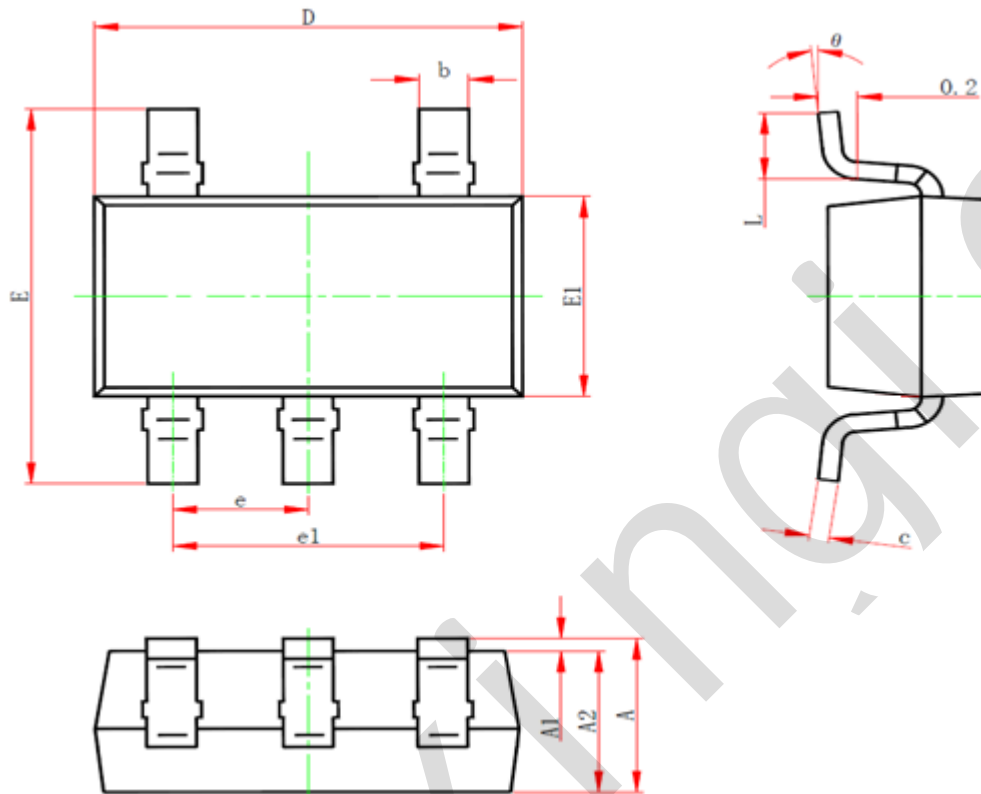

Symbol	Dimensions (mm)	
	Min.	Max.
A	-	1.26
A1	0.00	0.12
A2	1.00	1.20
b	0.30	0.50
c	0.10	0.20
D	2.82	3.02
E	2.60	3.00
E1	1.50	1.70
e	0.95	
e1	1.80	2.00
L	0.30	0.60
θ	0°	8°



5.2、SOT353

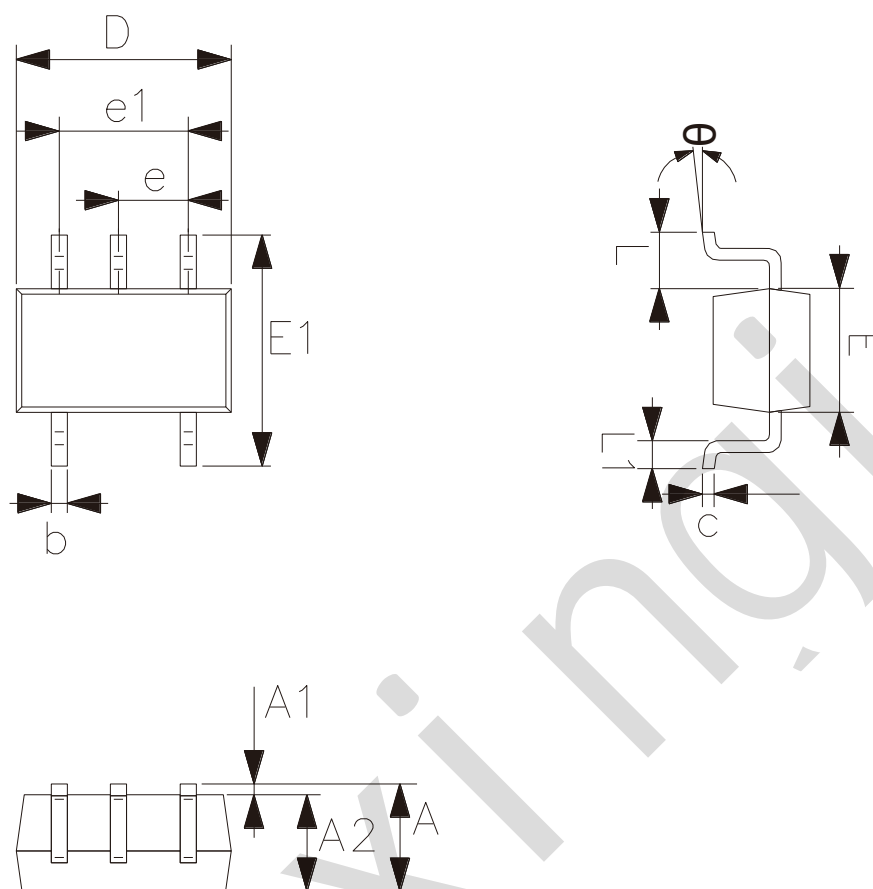

Symbol	Dimensions (mm)	
	Min.	Max.
A	0.90	1.10
A1	0.00	0.10
A2	0.90	1.00
b	0.15	0.35
c	0.11	0.175
D	2.00	2.20
E	1.15	1.35
E1	2.15	2.45
e	0.65	
e1	1.20	1.40
L	0.525	
L1	0.26	0.46
θ	0°	8°



5.3、DFN4

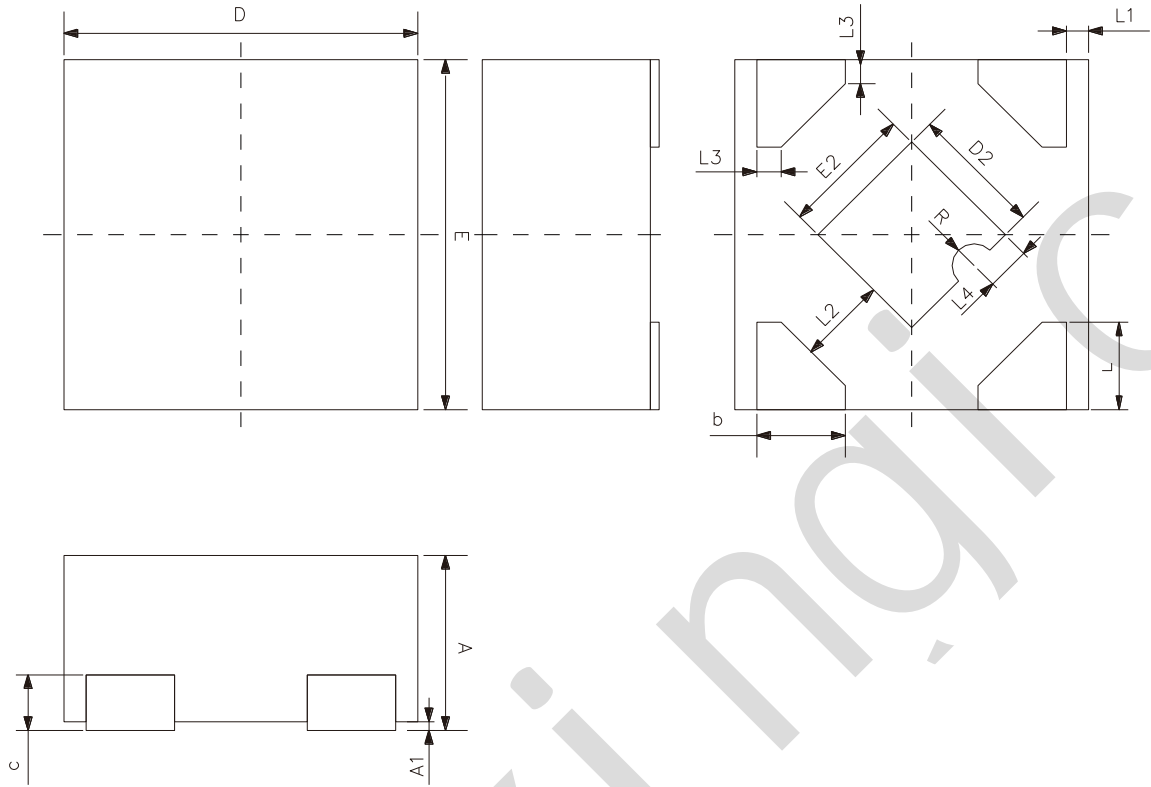

Symbol	Dimensions (mm)	
	Min.	Max.
A	0.37	0.43
A1	0.00	0.05
b	0.15	0.25
c	0.127	
D	0.75	0.85
D2	0.20	0.40
E	0.75	0.85
E2	0.20	0.40
e	0.50	
L	0.15	0.25
L1	0.05	
L2	0.20	
L3	0.055	
L4	0.10	
R	0.05	



5.4、XSON6(1*1*0.45-0.35)

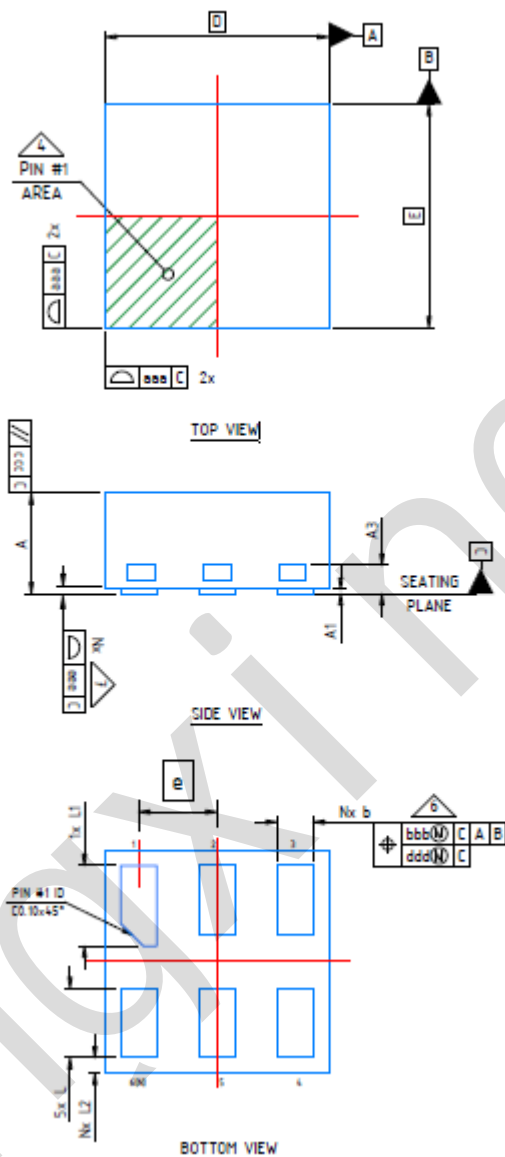

Symbol	Dimensions (mm)	
	Min.	Max.
A	0.41	0.50
A1	0.00	0.05
A3	0.127	
b	0.11	0.21
D	1.00	
E	1.00	
e	0.35	
L	0.26	0.36



灵星芯微 芯片经营

深圳市灵星芯微电子科技有限公司

Shenzhen Lingxing Microelectronics Technology Co., Ltd.

Tab: 835-12-B4

Number:SN74LVC1G32-AX-LJ-B019EN

L1	0.31	0.41
L2	0.02	0.12

Lingxingic



6、 Statements And Notes

6.1、 The name and content of Hazardous substances or Elements in the product

Part name	Hazardous substances or Elements									
	Lead and lead compounds	Mercury and mercury compounds	Cadmium and cadmium compounds	Hexavalent chromium compounds	Polybrominated biphenyls	Polybrominated biphenyl ethers	Dibutyl phthalate	Butylbenzyl phthalate	Di-2-ethylhexyl phthalate	Diisobutyl phthalate
Lead frame	○	○	○	○	○	○	○	○	○	○
Plastic resin	○	○	○	○	○	○	○	○	○	○
Chip	○	○	○	○	○	○	○	○	○	○
The lead	○	○	○	○	○	○	○	○	○	○
Plastic sheet installed	○	○	○	○	○	○	○	○	○	○
explanation	○: Indicates that the content of hazardous substances or elements in the detection limit of the following the SJ/T11363-2006 standard. ×: Indicates that the content of hazardous substances or elements exceeding the SJ/T11363-2006 Standard limit requirements.									

X-ON Electronics

Largest Supplier of Electrical and Electronic Components

Click to view similar products for [Logic Gates](#) category:

Click to view products by [lingxingic](#) manufacturer:

Other Similar products are found below :

[74HC85N](#) [NL17SG32DFT2G](#) [CD4068BE](#) [NL17SG86DFT2G](#) [NLX1G11AMUTCG](#) [NLX1G97MUTCG](#) [74LS38](#) [74LVC1G08Z-7](#)
[CD4025BE](#) [NLV17SZ00DFT2G](#) [NLV17SZ126DFT2G](#) [NLV27WZ17DFT2G](#) [NLV74HC02ADR2G](#) [74HC32S14-13](#) [74LS133](#)
[74LVC1G32Z-7](#) [74LVC1G86Z-7](#) [NLV74HC14ADR2G](#) [NLV74HC20ADR2G](#) [NLVVHC1G09DFT1G](#) [NLX2G86MUTCG](#)
[74LVC2G32RA3-7](#) [74LVC2G00HD4-7](#) [NL17SG02P5T5G](#) [74LVC2G86HK3-7](#) [NLVVHC1G14DFT2G](#) [NLX1G99DMUTWG](#)
[NLVVHC1G00DFT2G](#) [NLV7SZ57DFT2G](#) [NLV74VHC04DTR2G](#) [NLV27WZ00USG](#) [NLU1G86CMUTCG](#) [NLU1G08CMUTCG](#)
[NL17SZ32P5T5G](#) [NL17SZ00P5T5G](#) [NL17SH02P5T5G](#) [74AUP2G00RA3-7](#) [NLVVHC1GT00DFT2G](#) [NLV74HC02ADTR2G](#)
[NLX1G332CMUTCG](#) [NLVHCT132ADTR2G](#) [NL17SG86P5T5G](#) [NL17SZ05P5T5G](#) [NLV74VHC00DTR2G](#) [NLVVHC1G02DFT1G](#)
[NLV74HC86ADR2G](#) [74LVC2G32HK3-7](#) [74LVC2G86RA3-7](#) [NL17SZ38DBVT1G](#) [NLV18SZ00DFT2G](#)