



SN74LVC1G66 (LX) Bilateral Switch

Product Specification

Specification Revision History:

Version	Date	Description
2022-10-A1	2022-10	New
2023-11-A2	2023-11	Internal structure block diagram modified



灵星芯微 精密检测

Contents

1、 General Description.....	1
2、 Block Diagram And Pin Description	2
2.1、 Block Diagram	2
2.2、 Pin Configurations.....	2
2.3、 Pin Description.....	2
2.4、 Function Table.....	3
3、 Electrical Parameter	3
3.1、 Absolute Maximum Ratings.....	3
3.2、 Recommended Operating Conditions	3
3.3、 Electrical Characteristics	4
3.3.1、 DC Characteristics 1	4
3.3.2、 DC Characteristics 2.....	5
3.3.3、 ON Resistance 1	6
3.3.4、 ON Resistance 2	7
3.3.5、 AC Characteristics 1	8
3.3.6、 AC Characteristics 2.....	9
3.3.7、 Additional AC Characteristics	9
4、 Testing Circuit	10
4.1、 DC Testing Circuit	10
4.2、 ON Resistance Test Circuit	11
4.3、 AC Testing Circuit	11
4.4、 AC Testing Circuit	12
4.5、 Additional AC Testing Circuit	12
4.6、 Measurement Points	14
4.7、 Test Data	14
5、 Package Information	15
5.1、 SOT23-5.....	15
5.2、 SOT353	16
6、 Statements And Notes	17
6.1、 The name and content of Hazardous substances or Elements in the product.....	17
10.2、 Notes	17



灵星芯微 集成电路

1、General Description

The SN74LVC1G66 provides one single pole, single-throw analog switch function. It has two input/output terminals (Y and Z) and an active HIGH enable input pin (E). When E is LOW, the analog switch is turned off.

Features:

- Wide supply voltage range from 1.65 V to 5.5 V
- Very low ON resistance:
- Switch current capability of 32 mA
- CMOS low power consumption
- Specified from -40°C to +125°C
- Packaging information: SOT-23-5/SOT-353

Ordering Information:

Reel packing specifications:

Part number	Packaging form	Marking code	Reel quantity	Boxed reel quantity	Notes
SN74LVC1G66DB (LX)	SOT-23-5	DRXX	3000 PCS/reel	30000 PCS/box	Dimensions of plastic enclosure: 2.9mm×1.6mm Pin spacing:0.95mm
SN74LVC1G66DC (LX)	SOT-353	DRXX	3000 PCS/reel	30000 PCS/box	Dimensions of plastic enclosure: 2.1mm×1.3mm Pin spacing:0.65mm

Note 1: "XX" refers to variable content, meaning year and package batch serial number.

Note 2: If the physical information is inconsistent with the ordering information, please refer to the actual product.



2、Block Diagram And Pin Description

2.1、Block Diagram

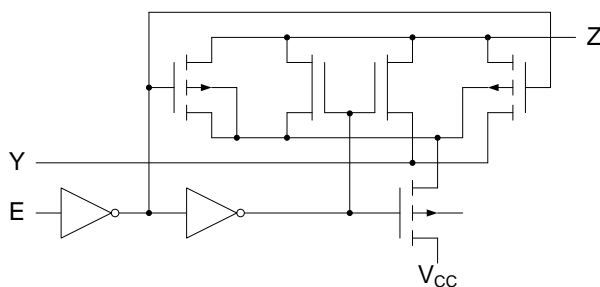
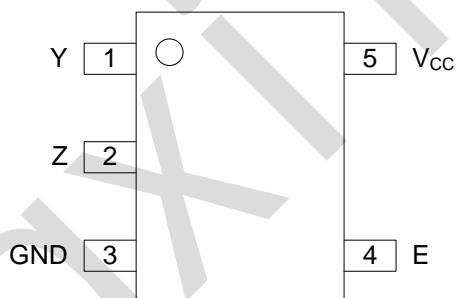

Figure 3. Logic diagram

2.2、Pin Configurations



2.3、Pin Description

Pin No.	Pin Name	Description
1	Y	independent input or output
2	Z	independent output or input
3	GND	ground (0V)
4	E	enable input (active HIGH)
5	V _{CC}	supply voltage



2.4、Function Table

Input E	Switch
L	OFF-state
H	ON-state

Note: H=HIGH voltage level; L=LOW voltage level.

3、Electrical Parameter

3.1、Absolute Maximum Ratings

($T_{amb}=25^{\circ}\text{C}$, voltages are referenced to GND (ground=0V), unless otherwise specified)

Parameter	Symbol	Conditions	Min.	Max.	Unit
supply voltage	V_{CC}	-	-0.5	+6.5	V
input clamping current	I_{IK}	$V_I < -0.5\text{V}$ or $V_I > V_{CC} + 0.5\text{V}$	-50	-	mA
input voltage	V_I	-	-0.5	+6.5	V
switch clamping current	I_{SK}	$V_I < -0.5\text{V}$ or $V_I > V_{CC} + 0.5\text{V}$	-50	-	mA
switch voltage	V_{SW}	enable and disable mode	-0.5	$V_{CC} + 0.5$	V
switch current	I_{SW}	$V_{SW} > -0.5\text{V}$ or $V_{SW} < V_{CC} + 0.5\text{V}$	-	± 50	mA
supply current	I_{CC}	-	-	100	mA
ground current	I_{GND}	-	-100	-	mA
storage temperature	T_{stg}	-	-65	+150	$^{\circ}\text{C}$
total power dissipation	P_{tot}	-	-	250	mW
soldering temperature	T_L	10s	260		$^{\circ}\text{C}$

3.2、Recommended Operating Conditions

Parameter	Symbol	Conditions	Min.	Typ.	Max.	Unit
supply voltage	V_{CC}	-	1.65	-	5.5	V
input voltage	V_I	-	0	-	5.5	V
switch voltage	V_{SW}	-	0	-	V_{CC}	V
ambient temperature	T_{amb}	-	-40	-	+125	$^{\circ}\text{C}$



3.3、Electrical Characteristics

3.3.1、DC Characteristics 1

($T_{amb}=-40^{\circ}\text{C}$ to $+85^{\circ}\text{C}$, voltages are referenced to GND (ground=0V), unless otherwise specified)

Parameter	Symbol	Conditions	Min.	Typ. ^[1]	Max.	Unit
HIGH-level input voltage	V_{IH}	$V_{CC}=1.65\text{V}$ to 1.95V	$0.65 \times V_{CC}$	-	-	V
		$V_{CC}=2.3\text{V}$ to 2.7V	1.7	-	-	V
		$V_{CC}=2.7\text{V}$ to 3.6V	2.0	-	-	V
		$V_{CC}=4.5\text{V}$ to 5.5V	$0.7 \times V_{Cc}$	-	-	V
LOW-level input voltage	V_{IL}	$V_{CC}=1.65\text{V}$ to 1.95V	-	-	$0.35 \times V_{CC}$	V
		$V_{CC}=2.3\text{V}$ to 2.7V	-	-	0.7	V
		$V_{CC}=2.7\text{V}$ to 3.6V	-	-	0.8	V
		$V_{CC}=4.5\text{V}$ to 5.5V	-	-	$0.3 \times V_{CC}$	V
input leakage current	I_I	pin E; $V_I=5.5\text{V}$ or GND; $V_{CC}=0\text{V}$ to $5.5\text{V}^{[2]}$	-	± 0.1	± 1	μA
OFF-state leakage current	$I_{(S)OFF}$	$V_{CC}=5.5\text{V}$; see Figure 4 ^[2]	-	± 0.1	± 0.2	μA
ON-state leakage current	$I_{(S)ON}$	$V_{CC}=5.5\text{V}$; see Figure 5 ^[2]	-	± 0.1	± 1	μA
supply current	I_{CC}	$V_I=5.5\text{V}$ or GND; $V_{SW}=\text{GND}$ or V_{CC} ; $V_{CC}=1.65\text{V}$ to $5.5\text{V}^{[2]}$	-	0.1	4	μA
additional supply current	ΔI_{CC}	pin E; $V_I=V_{CC}-0.6\text{V}$; $V_{SW}=\text{GND}$ or V_{CC} ; $V_{CC}=5.5\text{V}^{[2]}$	-	5	500	μA
input capacitance	C_I	-	-	2.0	-	pF
OFF-state capacitance	$C_{S(OFF)}$	-	-	6.5	-	pF
ON-state capacitance	$C_{S(ON)}$	-	-	11	-	pF

Note:

[1] All typical values are measured at $T_{amb}=25^{\circ}\text{C}$.

[2] These typical values are measured at $V_{CC}=3.3\text{V}$.



3.3.2、DC Characteristics 2

($T_{amb} = -40^{\circ}\text{C}$ to $+125^{\circ}\text{C}$, voltages are referenced to GND (ground=0V), unless otherwise specified)

Parameter	Symbol	Conditions	Min.	Typ.	Max.	Unit
HIGH-level input voltage	V_{IH}	$V_{CC}=1.65\text{V}$ to 1.95V	$0.65 \times V_{CC}$	-	-	V
		$V_{CC}=2.3\text{V}$ to 2.7V	1.7	-	-	V
		$V_{CC}=2.7\text{V}$ to 3.6V	2.0	-	-	V
		$V_{CC}=4.5\text{V}$ to 5.5V	$0.7 \times V_{Cc}$	-	-	V
LOW-level input voltage	V_{IL}	$V_{CC}=1.65\text{V}$ to 1.95V	-	-	$0.35 \times V_{CC}$	V
		$V_{CC}=2.3\text{V}$ to 2.7V	-	-	0.7	V
		$V_{CC}=2.7\text{V}$ to 3.6V	-	-	0.8	V
		$V_{CC}=4.5\text{V}$ to 5.5V	-	-	$0.3 \times V_{CC}$	V
input leakage current	I_I	pin E; $V_I=5.5\text{V}$ or GND; $V_{CC}=0\text{V}$ to $5.5\text{V}^{[1]}$	-	-	± 1	μA
OFF-state leakage current	$I_{(S)OFF}$	$V_{CC}=5.5\text{V}$; see Figure 4 ^[1]	-	-	± 0.5	μA
ON-state leakage current	$I_{(S)ON}$	$V_{CC}=5.5\text{V}$; see Figure 5 ^[1]	-	-	± 2	μA
supply current	I_{CC}	$V_I=5.5\text{V}$ or GND; $V_{SW}=\text{GND}$ or V_{CC} ; $V_{CC}=1.65\text{V}$ to $5.5\text{V}^{[1]}$	-	-	4	μA
additional supply current	ΔI_{CC}	pin E; $V_I=V_{CC}-0.6\text{V}$; $V_{SW}=\text{GND}$ or V_{CC} ; $V_{CC}=5.5\text{V}^{[1]}$	-	-	500	μA

Note:

[1] These typical values are measured at $V_{CC}=3.3\text{V}$.



3.3.3、ON Resistance 1

($T_{amb} = -40^{\circ}\text{C}$ to $+85^{\circ}\text{C}$, voltages are referenced to GND (ground=0V), unless otherwise specified)

Parameter	Symbol	Conditions	Min.	Typ. ^[1]	Max.	Unit	
ON resistance (peak)	$R_{ON(peak)}$	$V_I = \text{GND to } V_{CC}$; see Figure 6	$I_{sw} = 4 \text{ mA}$; $V_{CC} = 1.65\text{V to } 1.95\text{V}$	-	34.0	130	Ω
			$I_{sw} = 8\text{mA}$; $V_{CC} = 2.3\text{V to } 2.7\text{V}$	-	12.0	30	Ω
			$I_{sw} = 12\text{mA}$; $V_{CC} = 2.7\text{V}$	-	10.4	25	Ω
			$I_{sw} = 24\text{mA}$; $V_{CC} = 3\text{V to } 3.6\text{V}$	-	7.8	20	Ω
			$I_{sw} = 32\text{mA}$; $V_{CC} = 4.5\text{V to } 5.5\text{V}$	-	6.2	15	Ω
ON resistance (rail)	$R_{ON(rail)}$	$V_I = \text{GND}$; see Figure 6	$I_{sw} = 4 \text{ mA}$; $V_{CC} = 1.65\text{V to } 1.95\text{V}$	-	8.2	18	Ω
			$I_{sw} = 8\text{mA}$; $V_{CC} = 2.3\text{V to } 2.7\text{V}$	-	7.1	16	Ω
			$I_{sw} = 12\text{mA}$; $V_{CC} = 2.7\text{V}$	-	6.9	14	Ω
			$I_{sw} = 24\text{mA}$; $V_{CC} = 3\text{V to } 3.6\text{V}$	-	6.5	12	Ω
			$I_{sw} = 32\text{mA}$; $V_{CC} = 4.5\text{V to } 5.5\text{V}$	-	5.8	10	Ω
		$V_I = V_{CC}$; see Figure 6	$I_{sw} = 4 \text{ mA}$; $V_{CC} = 1.65\text{V to } 1.95\text{V}$	-	10.4	30	Ω
			$I_{sw} = 8\text{mA}$; $V_{CC} = 2.3\text{V to } 2.7\text{V}$	-	7.6	20	Ω
			$I_{sw} = 12\text{mA}$; $V_{CC} = 2.7\text{V}$	-	7.0	18	Ω
			$I_{sw} = 24\text{mA}$; $V_{CC} = 3\text{V to } 3.6\text{V}$	-	6.1	15	Ω
			$I_{sw} = 32\text{mA}$; $V_{CC} = 4.5\text{V to } 5.5\text{V}$	-	4.9	10	Ω
ON resistance (flatness)	$R_{ON(flatness)}$	$V_I = \text{GND to } V_{CC}$ ^[2]	$I_{sw} = 4 \text{ mA}$; $V_{CC} = 1.65\text{V to } 1.95\text{V}$	-	26.0	-	Ω
			$I_{sw} = 8\text{mA}$; $V_{CC} = 2.3\text{V to } 2.7\text{V}$	-	5.0	-	Ω
			$I_{sw} = 12\text{mA}$; $V_{CC} = 2.7\text{V}$	-	3.5	-	Ω
			$I_{sw} = 24\text{mA}$; $V_{CC} = 3\text{V to } 3.6\text{V}$	-	2.0	-	Ω
			$I_{sw} = 32\text{mA}$; $V_{CC} = 4.5\text{V to } 5.5\text{V}$	-	1.5	-	Ω

Note:

[1] Typical values are measured at $T_{amb} = 25^{\circ}\text{C}$ and nominal V_{CC} .

[2] Flatness is defined as the difference between the maximum and minimum value of ON resistance



measured at identical V_{CC} and temperature.

3.3.4、ON Resistance 2

($T_{amb}=-40^{\circ}\text{C}$ to $+125^{\circ}\text{C}$, voltages are referenced to GND (ground=0V), unless otherwise specified)

Parameter	Symbol	Conditions	Min.	Typ.	Max.	Unit	
ON resistance (peak)	$R_{ON(peak)}$	$V_I=GND$ to V_{CC} ; see Figure 6	$I_{sw} = 4\text{ mA}$; $V_{CC}=1.65\text{V}$ to 1.95V	-	-	195	Ω
			$I_{sw}=8\text{mA}$; $V_{CC}=2.3\text{V}$ to 2.7V	-	-	45	Ω
			$I_{sw}=12\text{mA}$; $V_{CC}=2.7\text{V}$	-	-	38	Ω
			$I_{sw}=24\text{mA}$; $V_{CC}=3\text{V}$ to 3.6V	-	-	30	Ω
			$I_{sw}=32\text{mA}$; $V_{CC}=4.5\text{V}$ to 5.5V	-	-	23	Ω
ON resistance (rail)	$R_{ON(rail)}$	$V_I=GND$; see Figure 6	$I_{sw} = 4\text{ mA}$; $V_{CC}=1.65\text{V}$ to 1.95V	-	-	27	Ω
			$I_{sw}=8\text{mA}$; $V_{CC}=2.3\text{V}$ to 2.7V	-	-	24	Ω
			$I_{sw}=12\text{mA}$; $V_{CC}=2.7\text{V}$	-	-	21	Ω
			$I_{sw}=24\text{mA}$; $V_{CC}=3\text{V}$ to 3.6V	-	-	18	Ω
			$I_{sw}=32\text{mA}$; $V_{CC}=4.5\text{V}$ to 5.5V	-	-	15	Ω
		$V_I=V_{CC}$; see Figure 6	$I_{sw} = 4\text{ mA}$; $V_{CC}=1.65\text{V}$ to 1.95V	-	-	45	Ω
			$I_{sw}=8\text{mA}$; $V_{CC}=2.3\text{V}$ to 2.7V	-	-	30	Ω
			$I_{sw}=12\text{mA}$; $V_{CC}=2.7\text{V}$	-	-	27	Ω
			$I_{sw}=24\text{mA}$; $V_{CC}=3\text{V}$ to 3.6V	-	-	23	Ω
			$I_{sw}=32\text{mA}$; $V_{CC}=4.5\text{V}$ to 5.5V	-	-	15	Ω



3.3.5、AC Characteristics 1

($T_{amb} = -40^{\circ}\text{C}$ to $+85^{\circ}\text{C}$, voltages are referenced to GND (ground=0V), unless otherwise specified)

Parameter	Symbol	Conditions	Min.	Typ. ^[1]	Max.	Unit
propagation delay	t_{PHL}, t_{PLH}	Y to Z or Z to Y; see Figure 13 ^[2]				
		$V_{CC} = 1.65\text{V}$ to 1.95V	-	0.8	2.0	ns
		$V_{CC} = 2.3\text{V}$ to 2.7V	-	0.4	1.2	ns
		$V_{CC} = 2.7\text{V}$	-	0.4	1.0	ns
		$V_{CC} = 3.0\text{V}$ to 3.6V	-	0.3	0.8	ns
		$V_{CC} = 4.5\text{V}$ to 5.5V	-	0.2	0.6	ns
enable time	t_{PZH}, t_{PZL}	E to Y or Z; see Figure 14				
		$V_{CC} = 1.65\text{V}$ to 1.95V	1.0	5.3	12	ns
		$V_{CC} = 2.3\text{V}$ to 2.7V	1.0	3.0	6.5	ns
		$V_{CC} = 2.7\text{V}$	1.0	2.6	6.0	ns
		$V_{CC} = 3.0\text{V}$ to 3.6V	1.0	2.5	5.0	ns
		$V_{CC} = 4.5\text{V}$ to 5.5V	1.0	1.9	4.2	ns
disable time	t_{PLZ}, t_{PHZ}	E to Y or Z; see Figure 14				
		$V_{CC} = 1.65\text{V}$ to 1.95V	1.0	4.2	10	ns
		$V_{CC} = 2.3\text{V}$ to 2.7V	1.0	2.4	6.9	ns
		$V_{CC} = 2.7\text{V}$	1.0	3.6	7.5	ns
		$V_{CC} = 3.0\text{V}$ to 3.6V	1.0	3.4	6.5	ns
		$V_{CC} = 4.5\text{V}$ to 5.5V	1.0	2.5	5.0	ns

Note:

[1] Typical values are measured at $T_{amb} = 25^{\circ}\text{C}$ and nominal V_{CC} .

[2] Propagation delay is the calculated RC time constant of the typical ON resistance of the switch and the specified capacitance when driven by an ideal voltage source (zero output impedance).



3.3.6、AC Characteristics 2

($T_{amb}=-40^{\circ}\text{C}$ to $+125^{\circ}\text{C}$, voltages are referenced to GND (ground=0V), unless otherwise specified)

Parameter	Symbol	Conditions	Min.	Typ.	Max.	Unit
propagation delay	t_{PHL}, t_{PLH}	Y to Z or Z to Y; see Figure 13 ^[1]				
		$V_{CC}=1.65\text{V}$ to 1.95V	-	-	3.0	ns
		$V_{CC}=2.3\text{V}$ to 2.7V	-	-	2.0	ns
		$V_{CC}=2.7\text{V}$	-	-	1.5	ns
		$V_{CC}=3.0\text{V}$ to 3.6V	-	-	1.5	ns
		$V_{CC}=4.5\text{V}$ to 5.5V	-	-	1.0	ns
enable time	t_{PZH}, t_{PZL}	E to Y or Z; see Figure 14				
		$V_{CC}=1.65\text{V}$ to 1.95V	1.0	-	15.5	ns
		$V_{CC}=2.3\text{V}$ to 2.7V	1.0	-	8.5	ns
		$V_{CC}=2.7\text{V}$	1.0	-	8.0	ns
		$V_{CC}=3.0\text{V}$ to 3.6V	1.0	-	6.5	ns
		$V_{CC}=4.5\text{V}$ to 5.5V	1.0	-	5.5	ns
disable time	t_{PLZ}, t_{PHZ}	E to Y or Z; see Figure 14				
		$V_{CC}=1.65\text{V}$ to 1.95V	1.0	-	13	ns
		$V_{CC}=2.3\text{V}$ to 2.7V	1.0	-	9.0	ns
		$V_{CC}=2.7\text{V}$	1.0	-	9.5	ns
		$V_{CC}=3.0\text{V}$ to 3.6V	1.0	-	8.5	ns
		$V_{CC}=4.5\text{V}$ to 5.5V	1.0	-	6.5	ns

Note:

[1] Propagation delay is the calculated RC time constant of the typical ON resistance of the switch and the specified capacitance when driven by an ideal voltage source (zero output impedance).

3.3.7、Additional AC Characteristics

($T_{amb}=25^{\circ}\text{C}$, voltages are referenced to GND (ground=0V), unless otherwise specified)

Parameter	Symbol	Conditions	Min.	Typ.	Max.	Unit	
total harmonic distortion	THD	$R_L=10\text{k}\Omega; C_L=50\text{pF}; f_i=1\text{kHz};$ see Figure 7	$V_{CC}=1.65\text{V}$	-	0.032	-	%
			$V_{CC}=2.3\text{V}$	-	0.008	-	%
			$V_{CC}=3.0\text{V}$	-	0.006	-	%
			$V_{CC}=4.5\text{V}$	-	0.001	-	%
		$R_L=10\text{k}\Omega; C_L=50\text{pF}; f_i=10\text{kHz};$ see Figure 7	$V_{CC}=1.65\text{V}$	-	0.068	-	%
			$V_{CC}=2.3\text{V}$	-	0.009	-	%
			$V_{CC}=3.0\text{V}$	-	0.008	-	%
			$V_{CC}=4.5\text{V}$	-	0.006	-	%
-3dB frequency response	$f_{(-3\text{dB})}$	$R_L=600\Omega; C_L=50\text{pF};$ see Figure 8	$V_{CC}=1.65\text{V}$	-	135	-	MHz
			$V_{CC}=2.3\text{V}$	-	145	-	MHz
			$V_{CC}=3.0\text{V}$	-	150	-	MHz
			$V_{CC}=4.5\text{V}$	-	155	-	MHz
		$R_L=50\Omega; C_L=5\text{pF};$ see Figure 8	$V_{CC}=1.65\text{V}$	-	>500	-	MHz
			$V_{CC}=2.3\text{V}$	-	>500	-	MHz
			$V_{CC}=3.0\text{V}$	-	>500	-	MHz
			$V_{CC}=4.5\text{V}$	-	>500	-	MHz
		$R_L=50\Omega; C_L=10\text{pF};$ see Figure 8	$V_{CC}=1.65\text{V}$	-	200	-	MHz
			$V_{CC}=2.3\text{V}$	-	350	-	MHz



			$V_{CC}=3.0V$	-	410	-	MHz
			$V_{CC}=4.5V$	-	440	-	MHz
isolation (OFF-state)	α_{iso}	$R_L=600\Omega; C_L=50pF;$ $f_i=1MHz;$ see Figure 9	$V_{CC}=1.65V$	-	-46	-	dB
			$V_{CC}=2.3V$	-	-46	-	dB
			$V_{CC}=3.0V$	-	-46	-	dB
			$V_{CC}=4.5V$	-	-46	-	dB
		$R_L=50\Omega; C_L=5pF;$ $f_i=1MHz;$ see Figure 9	$V_{CC}=1.65V$	-	-37	-	dB
			$V_{CC}=2.3V$	-	-37	-	dB
			$V_{CC}=3.0V$	-	-37	-	dB
			$V_{CC}=4.5V$	-	-37	-	dB
crosstalk voltage	V_{ct}	between digital input and switch; $R_L=600\Omega;$ $C_L=50pF; f_i=1MHz;$ $t_r=t_f=2ns;$ see Figure 10	$V_{CC}=1.65V$	-	69	-	mV
			$V_{CC}=2.3V$	-	87	-	mV
			$V_{CC}=3.0V$	-	156	-	mV
			$V_{CC}=4.5V$	-	302	-	mV
charge injection	Q_{inj}	$C_L=0.1nF; V_{gen}=0V;$ $R_{gen}=0\Omega;$ $f_i=1MHz; R_L=1M\Omega;$ see Figure 11	$V_{CC}=1.8V$	-	3.3	-	pC
			$V_{CC}=2.5V$	-	4.1	-	pC
			$V_{CC}=3.3V$	-	5.0	-	pC
			$V_{CC}=4.5V$	-	6.4	-	pC
			$V_{CC}=5.5V$	-	7.5	-	pC

4、Testing Circuit

4.1、DC Testing Circuit

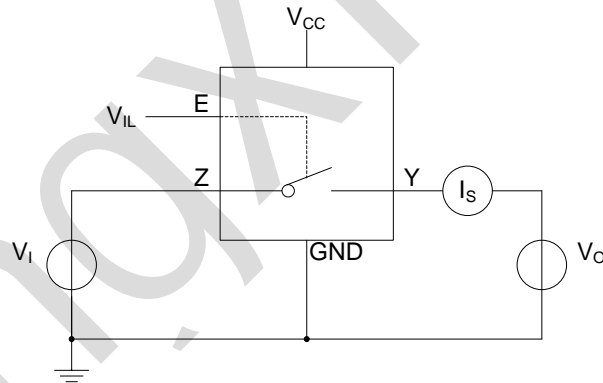

$V_I=V_{CC}$ or GND and $V_O=GND$ or V_{CC} .

Figure 4. Test circuit for measuring OFF-state leakage current

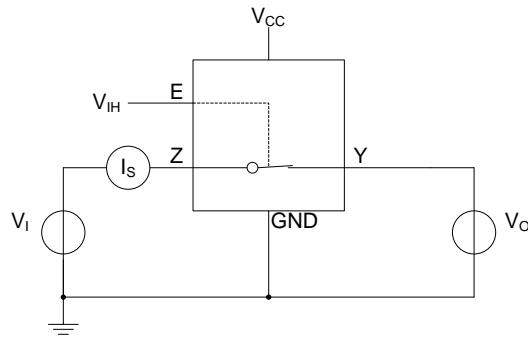

$V_I = V_{CC}$ or GND and $V_O = \text{open circuit}$.

Figure 5. Test circuit for measuring ON-state leakage current

4.2、ON Resistance Test Circuit

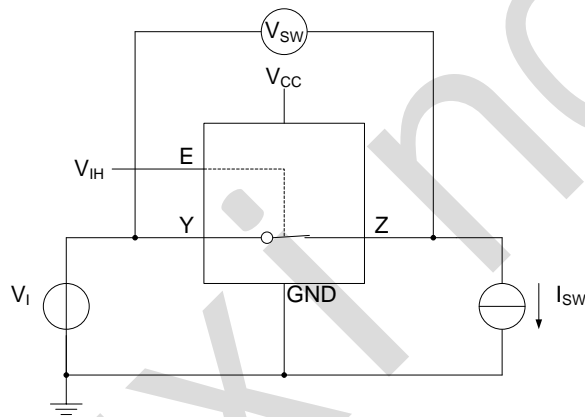

$$R_{ON} = V_{SW} / I_{SW}$$

Figure 6. Test circuit for measuring ON resistance

4.3、AC Testing Circuit

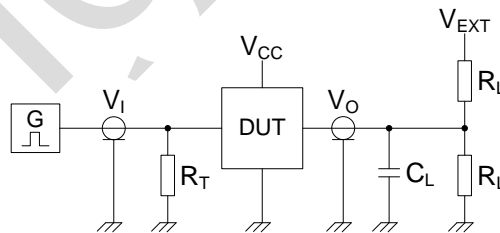

Definitions for test circuit:

R_L = Load resistance.

C_L = Load capacitance including jig and probe capacitance.

R_T = Termination resistance should be equal to the output impedance Z_o of the pulse generator.

V_{EXT} = External voltage for measuring switching times.

Figure 7. Test circuit for measuring switching times



4.4. AC Testing Circuit

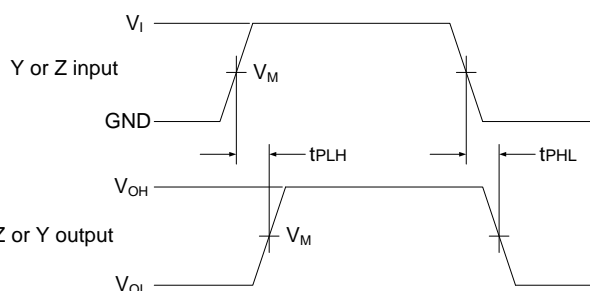

Figure 8. Input (Y or Z) to output (Z or Y) propagation delays

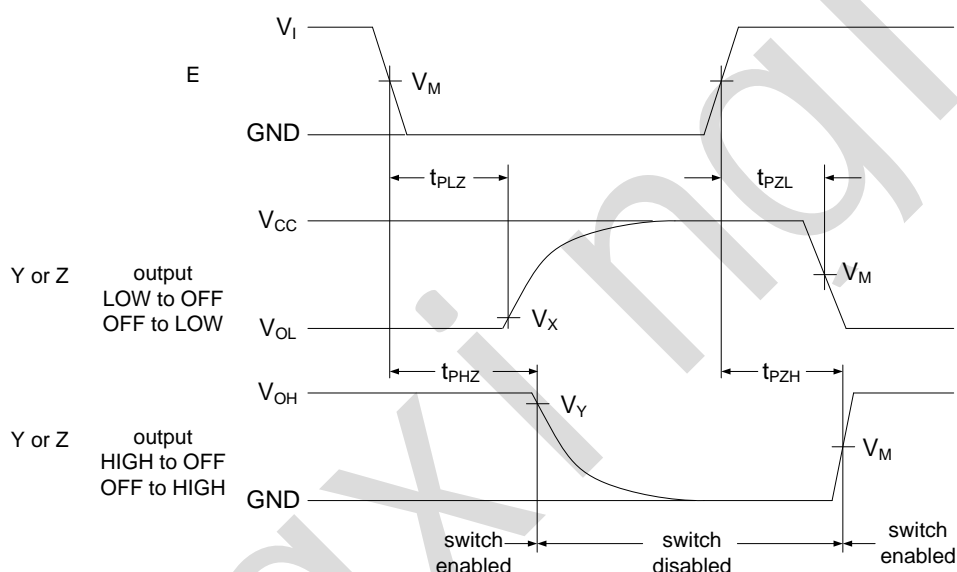
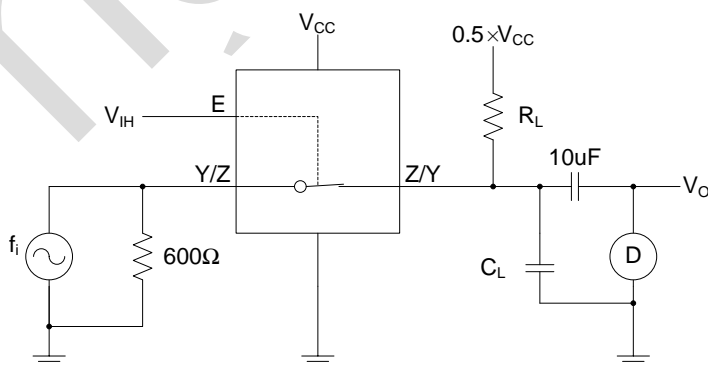

Figure 9. Enable and disable times

4.5. Additional AC Testing Circuit



Test conditions:

$V_{CC}=1.65V$: $V_i=1.4V$ (p-p).

$V_{CC}=2.3V$: $V_i=2V$ (p-p).

$V_{CC}=3V$: $V_i=2.5V$ (p-p).

$V_{CC}=4.5V$: $V_i=4V$ (p-p).

Figure 10. Test circuit for measuring total harmonic distortion

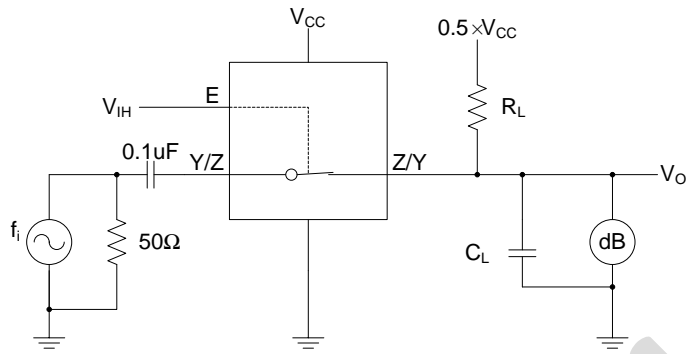

Adjust f_i voltage to obtain 0dBm level at output. Increase f_i frequency until dB meter reads -3dB.

Figure 11. Test circuit for measuring the frequency response when switch is in ON-state

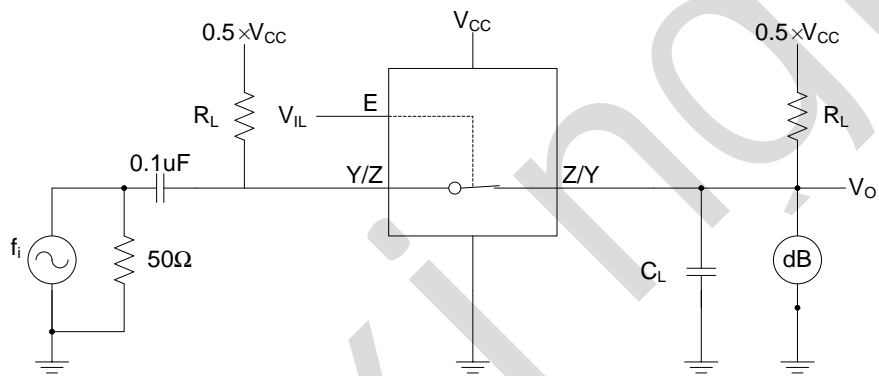

Adjust f_i voltage to obtain 0dBm level at input.

Figure 12. Test circuit for measuring isolation (OFF-state)

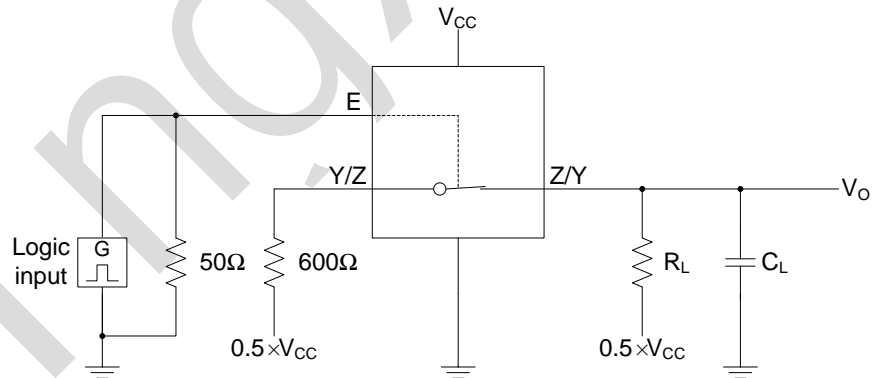
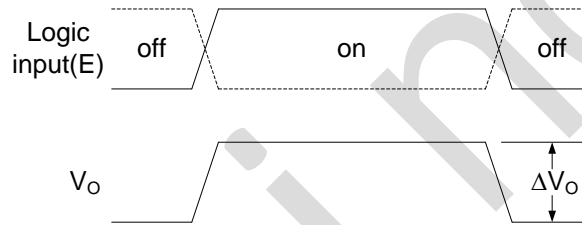
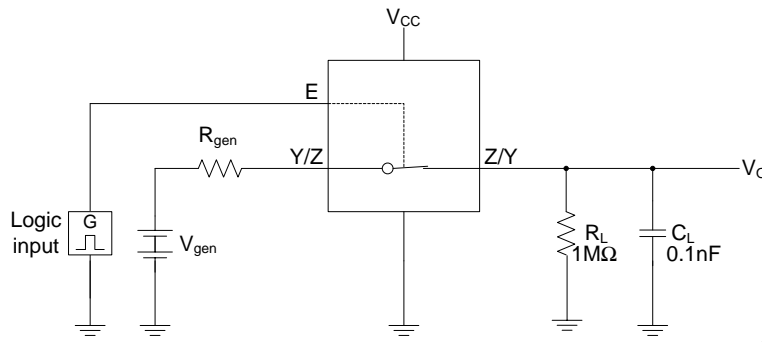

Figure 13. Test circuit for measuring crosstalk between digital input and switch



$$Q_{inj} = \Delta V_O \times C_L$$

ΔV_O = output voltage variation.

R_{gen} = generator resistance.

V_{gen} = generator voltage.

Figure 14. Test circuit for measuring charge injection

4.6、Measurement Points

Supply voltage	Input	Output		
V_{CC}	V_M	V_M	V_X	V_Y
1.65V to 1.95V	$0.5 \times V_{CC}$	$0.5 \times V_{CC}$	$V_{OL} + 0.15V$	$V_{OH} - 0.15V$
2.3V to 2.7V	$0.5 \times V_{CC}$	$0.5 \times V_{CC}$	$V_{OL} + 0.15V$	$V_{OH} - 0.15V$
2.7V	1.5V	1.5V	$V_{OL} + 0.3V$	$V_{OH} - 0.3V$
3V to 3.6V	1.5V	1.5V	$V_{OL} + 0.3V$	$V_{OH} - 0.3V$
4.5V to 5.5V	$0.5 \times V_{CC}$	$0.5 \times V_{CC}$	$V_{OL} + 0.3V$	$V_{OH} - 0.3V$

4.7、Test Data

Supply voltage	Input		Load		V_{EXT}		
V_{CC}	V_I	t_r, t_f	C_L	R_L	t_{PLH}, t_{PHL}	t_{PZH}, t_{PHZ}	t_{PZL}, t_{PLZ}
1.65V to 1.95V	V_{CC}	$\leq 2.0ns$	30pF	1kΩ	open	GND	$2 \times V_{CC}$
2.3V to 2.7V	V_{CC}	$\leq 2.0ns$	30pF	500Ω	open	GND	$2 \times V_{CC}$
2.7V	2.7V	$\leq 2.5ns$	50pF	500Ω	open	GND	$2 \times V_{CC}$
3V to 3.6V	2.7V	$\leq 2.5ns$	50pF	500Ω	open	GND	$2 \times V_{CC}$
4.5V to 5.5V	V_{CC}	$\leq 2.5ns$	50pF	500Ω	open	GND	$2 \times V_{CC}$



5、Package Information

5.1、SOT23-5

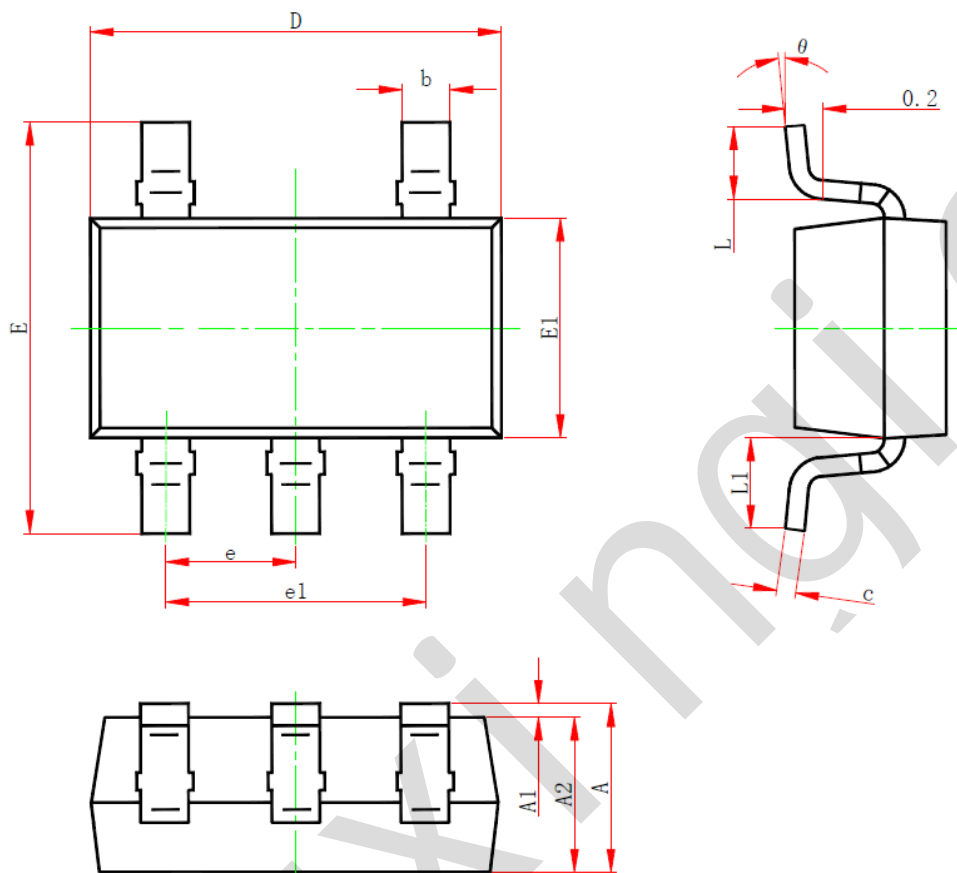

Symbol	Dimensions (mm)	
	Min.	Max.
A	-	1.26
A1	0.00	0.12
A2	1.00	1.20
b	0.30	0.50
c	0.10	0.20
D	2.82	3.02
E	2.60	3.00
E1	1.50	1.70
e	0.95	
e1	1.80	2.00
L	0.30	0.60
θ	0°	8°



5.2、SOT353

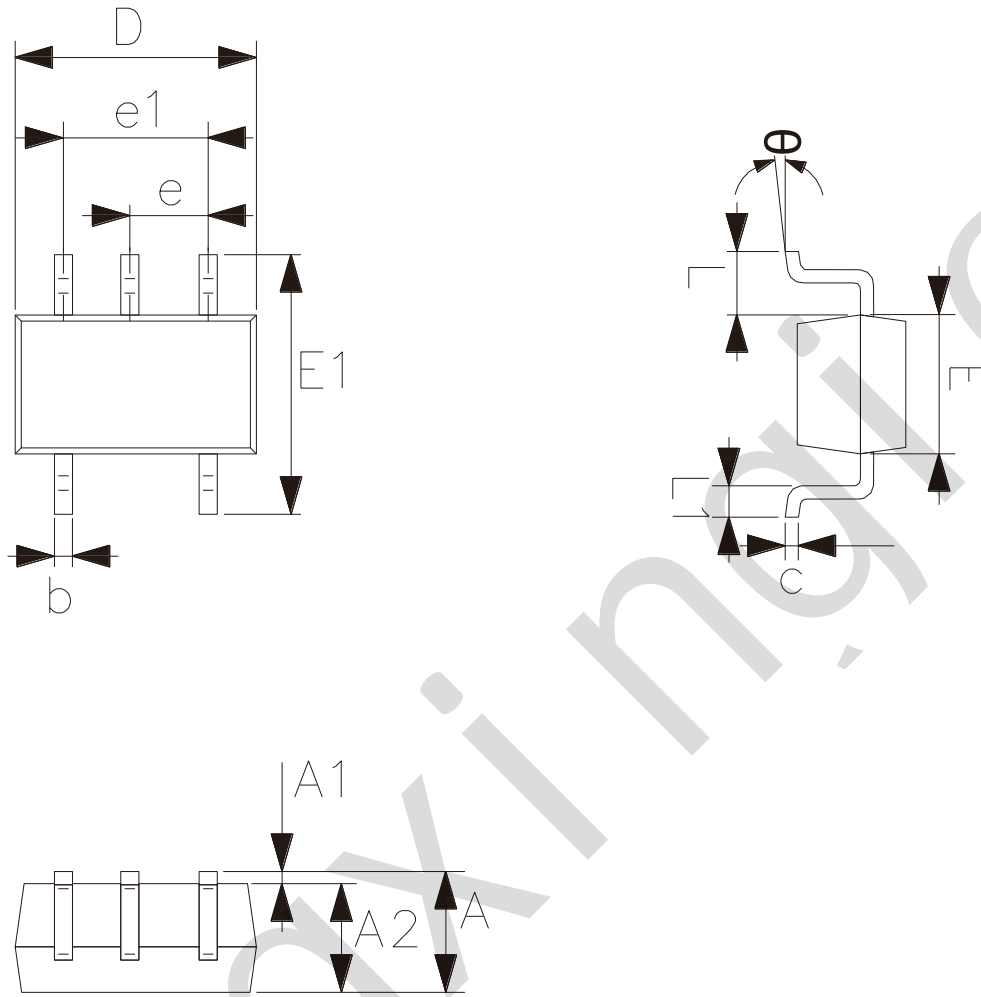

Symbol	Dimensions (mm)	
	Min.	Max.
A	0.90	1.10
A1	0.00	0.10
A2	0.90	1.00
b	0.15	0.35
c	0.11	0.175
D	2.00	2.20
E	1.15	1.35
E1	2.15	2.45
e	0.65	
e1	1.20	1.40
L	0.525	
L1	0.26	0.46
θ	0°	8°



6、 Statements And Notes

6.1、 The name and content of Hazardous substances or Elements in the product

Part name	Hazardous substances or Elements									
	Lead and lead compounds	Mercury and mercury compounds	Cadmium and cadmium compounds	Hexavalent chromium compounds	Polybrominated biphenyls	Polybrominated biphenyl ethers	Dibutyl phthalate	Butylbenzyl phthalate	Di-2-ethylhexyl phthalate	Diisobutyl phthalate
Lead frame	○	○	○	○	○	○	○	○	○	○
Plastic resin	○	○	○	○	○	○	○	○	○	○
Chip	○	○	○	○	○	○	○	○	○	○
The lead	○	○	○	○	○	○	○	○	○	○
Plastic sheet installed	○	○	○	○	○	○	○	○	○	○
explanation	○: Indicates that the content of hazardous substances or elements in the detection limit of the following the SJ/T11363-2006 standard. ×: Indicates that the content of hazardous substances or elements exceeding the SJ/T11363-2006 Standard limit requirements.									

6.2、 Notes

Recommended carefully reading this information before the use of this product;

The information in this document are subject to change without notice;

This information is using to the reference only, the company is not responsible for any loss;

The company is not responsible for the any infringement of the third party patents or other rights of the responsibility.

X-ON Electronics

Largest Supplier of Electrical and Electronic Components

Click to view similar products for [Analogue Switch ICs](#) category:

Click to view products by [lingxingic](#) manufacturer:

Other Similar products are found below :

[FSA3051TMX](#) [NLAS5223BLMNR2G](#) [NLX2G66DMUTCG](#) [425541DB](#) [DG403DY](#) [099044FB](#) [MAX4762ETB+](#) [NLAS3799BMNR2G](#)
[NLAS5123MNR2G](#) [ISL84684IR](#) [PI5A4157CEX](#) [PI5A4599BCEX](#) [NLAS4717EPFCT1G](#) [PI5A3167CCEX](#) [SLAS3158MNR2G](#) [PI5A392AQE](#)
[ADG714BCPZ-REEL7](#) [DG333ALDW-T1-E3](#) [ISL43113IB](#) [ISL43140IB](#) [ISL43140IBZ-T](#) [ISL43143IR](#) [ISL43L120IR](#) [ISL43L121IR](#)
[ISL43L122IR](#) [ISL43L220IR](#) [ISL43L410IR](#) [ISL43L420IR](#) [ISL43L710IR](#) [ISL43L711IR](#) [ISL43L712IR](#) [ISL84053IA](#) [ISL84514IB](#)
[ISL84516IB](#) [ISL84684IUZ-T](#) [LNLASB3157DFT2G](#) [NLAS324US](#) [NLASTV4599DFT2G](#) [ADG842YKSZ-REEL7](#) [WAS4766C-9/TR](#)
[WAS7227Q-10/TR](#) [WAS4646C-36/TR](#) [WAS4735Q-16/TR](#) [BL1532TQFN](#) [RS2233YS16](#) [CH483M](#) [TMUX7236RUMR](#) [ADG836YRMZ-](#)
[REEL](#) [MS3494](#) [ADG412BR-REEL7](#)