



# SN74LVC/LVCH1T45 (LX) Dual Supply Translating Transceiver; 3-State

## Product Specification

### Specification Revision History:

Version	Date	Description
2021-04-A1	2021-04	New
2023-04-B1	2023-04	Update the template



# Contents

<b>1、 General Description.....</b>	<b>4</b>
<b>2、 Block Diagram And Pin Description .....</b>	<b>6</b>
2.1、 Block Diagram .....	6
2.2、 Pin Configurations.....	6
2.3、 Pin Description .....	7
2.4、 Function Table.....	7
<b>3、 Electrical Parameter .....</b>	<b>7</b>
3.1、 Absolute Maximum Ratings.....	7
3.2、 Recommended Operating Conditions .....	8
3.3、 Electrical Characteristics .....	8
3.3.1、 DC Characteristics 1 .....	8
3.3.2、 DC Characteristics 2 .....	9
3.3.3、 DC Characteristics 3 .....	11
3.3.4、 AC Characteristics 1 .....	13
3.3.5、 AC Characteristics 2 .....	16
<b>4、 Testing Circuit .....</b>	<b>18</b>
4.1、 AC Testing Circuit .....	18
4.2、 Test Data .....	19
4.3、 AC Testing Waveforms.....	19
4.4、 Measurement Points .....	19
<b>5、 Characteristic Curve .....</b>	<b>20</b>
<b>6、 Typical Application Circuit And Application Note.....</b>	<b>26</b>
6.1、 Unidirectional Logic Level-shifting Application .....	26
6.2、 Bidirectional Logic Level-shifting Application .....	27
6.3、 Power-up Considerations .....	28
6.4、 Enable Times.....	28
<b>7、 Package Information .....</b>	<b>29</b>
7.1、 SOT-23-6.....	29
7.2、 SOT-363.....	30
<b>8、 Statements .....</b>	<b>31</b>
8.1、 The name and content of Hazardous substances or Elements in the product.....	31



灵星芯微 肖芯经营

## 1、General Description

The SN74LVC1T45; SN74LVCH1T45 are single bit, dual supply transceivers with 3-state outputs that enable bidirectional level translation. They feature two 1-bit input-output ports (A and B), a direction control input (DIR) and dual supply pins ( $V_{CC(A)}$  and  $V_{CC(B)}$ ). Both  $V_{CC(A)}$  and  $V_{CC(B)}$  can be supplied at any voltage between 1.2 V and 5.5 V making the device suitable for translating between any of the low voltage nodes (1.2V, 1.5V, 1.8V, 2.5V, 3.3V and 5.0V). Pins A and DIR are referenced to  $V_{CC(A)}$  and pin B is referenced to  $V_{CC(B)}$ . A HIGH on DIR allows transmission from A to B and a LOW on DIR allows transmission from B to A.

The devices are fully specified for partial power-down applications using  $I_{OFF}$ . The  $I_{OFF}$  circuitry disables the output, preventing any damaging backflow current through the device when it is powered down. In suspend mode when either  $V_{CC(A)}$  or  $V_{CC(B)}$  are at GND level, both A port and B port are in the high-impedance OFF-state.

Active bus hold circuitry in the SN74LVCH1T45 holds unused or floating data inputs at a valid logic level.

### Features:

- Wide supply voltage range:  
 $V_{CC(A)}$ : 1.2V to 5.5V  
 $V_{CC(B)}$ : 1.2V to 5.5V
- Maximum data rates:  
420 Mbps (3.3V to 5.0V translation)  
210 Mbps (translate to 3.3V)  
140 Mbps (translate to 2.5V)  
75 Mbps (translate to 1.8V)  
60 Mbps (translate to 1.5V)
- Suspend mode
- $\pm 24\text{mA}$  output drive ( $V_{CC}=3.0\text{V}$ )
- Inputs accept voltages up to 5.5V
- Low power consumption: 16 $\mu\text{A}$  maximum  $I_{CC}$
- $I_{OFF}$  circuitry provides partial Power-down mode operation
- Specified from  $-40^{\circ}\text{C}$  to  $+125^{\circ}\text{C}$
- Packaging information: SOT23-6/SOT363



**Ordering Information:**

**Reel packing specifications:**

Part number	Packaging form	Marking code	Reel quantity	Boxed reel quantity	Notes
SN74LVC1T45DB (LX)	SOT23-6	CXXX	3000 PCS/reel	30000 PCS/box	Dimensions of plastic enclosure: 2.9mm×1.6mm Pin spacing: 0.95mm
SN74LVC1T45DC (LX)	SOT363	CXXX	3000 PCS/reel	30000 PCS/box	Dimensions of plastic enclosure: 2.1mm×1.3mm Pin spacing: 0.65mm
SN74LVCH1T45DB (LX)	SOT23-6	CYXX	3000 PCS/reel	30000 PCS/box	Dimensions of plastic enclosure: 2.9mm×1.6mm Pin spacing: 0.95mm
SN74LVCH1T45DC (LX)	SOT363	CYXX	3000 PCS/reel	30000 PCS/box	Dimensions of plastic enclosure: 2.1mm×1.3mm Pin spacing: 0.65mm

Note 1: "XX" refers to variable content, meaning year and package batch serial number.

Note 2: If the physical information is inconsistent with the ordering information, please refer to the actual product.



## 2、Block Diagram And Pin Description

### 2.1、Block Diagram

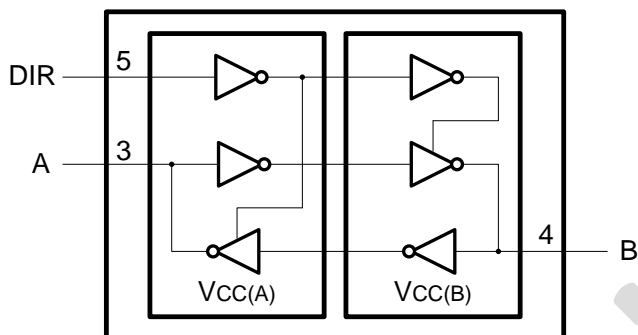

Figure 1. Logic symbol

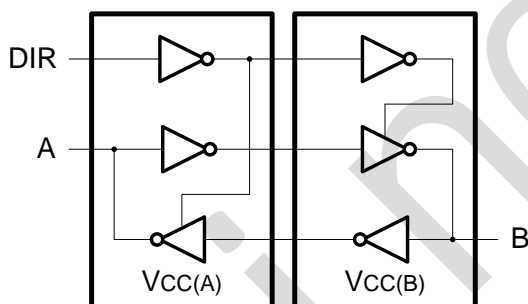
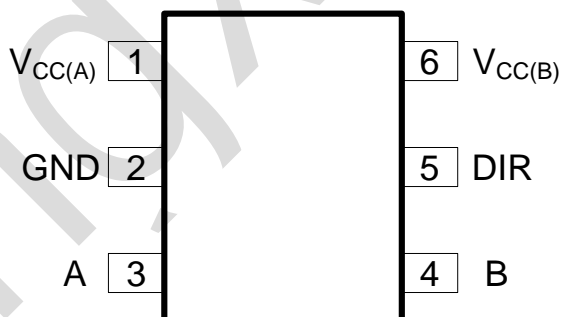

Figure 2. Logic diagram

### 2.2、Pin Configurations





### 2.3、Pin Description

Pin No.	Pin Name	Description
1	$V_{CC(A)}$	supply voltage A (port A and DIR)
2	GND	ground (0V)
3	A	data input or output
4	B	data input or output
5	DIR	direction control
6	$V_{CC(B)}$	supply voltage B (port B)

### 2.4、Function Table

Supply Voltage $V_{CC(A)}, V_{CC(B)}$	Input DIR	Input/output	
		A	B
1.2V to 5.5V	L	A=B	input
1.2V to 5.5V	H	input	B=A
GND	X	Z	Z

Note:

- [1] H=HIGH voltage level; L=LOW voltage level; X=don't care; Z=high-impedance OFF-state.  
[2] The input circuit of the data I/O is always active.  
[3] When either  $V_{CC(A)}$  or  $V_{CC(B)}$  is at GND level, the device goes into suspend mode.

## 3、Electrical Parameter

### 3.1、Absolute Maximum Ratings

(Voltages are referenced to GND (ground=0V), unless otherwise specified)

Characteristic	Symbol	Conditions	Min.	Max.	Unit
supply voltage A	$V_{CC(A)}$	-	-0.5	+6.5	V
supply voltage B	$V_{CC(B)}$	-	-0.5	+6.5	V
input clamping current	$I_{IK}$	$V_I < 0V$	-50	-	mA
input voltage	$V_I$	[1]	-0.5	+6.5	V
output clamping current	$I_{OK}$	$V_O < 0V$	-50	-	mA
output voltage	$V_O$	Active mode [1][2][3]	-0.5	$V_{CCO}+0.5$	V
		Suspend or 3-state mode [1]	-0.5	+6.5	V
output current	$I_O$	$V_O=0V$ to $V_{CCO}$ [2]	-	$\pm 50$	mA
supply current	$I_{CC}$	$I_{CC(A)}$ or $I_{CC(B)}$	-	100	mA
ground current	$I_{GND}$	-	-100	-	mA
storage temperature	$T_{stg}$	-	-65	+150	°C
total power dissipation	$P_{tot}$	-	-	250	mW
soldering temperature	$T_L$	10s	-	260	°C

Note:

- [1] The minimum input voltage ratings and output voltage ratings may be exceeded if the input and output current ratings are observed.  
[2]  $V_{CCO}$  is the supply voltage associated with the output port.  
[3]  $V_{CCO}+0.5V$  should not exceed 6.5V.



### 3.2. Recommended Operating Conditions

Characteristic	Symbol	Conditions	Min.	Max.	Unit
supply voltage A	$V_{CC(A)}$	-	1.2	5.5	V
supply voltage B	$V_{CC(B)}$	-	1.2	5.5	V
input voltage	$V_I$	-	0	5.5	V
output voltage	$V_O$	Active mode <sup>[1]</sup>	0	$V_{CCO}$	V
		Suspend or 3-state mode	0	5.5	V
ambient temperature input transition rise and fall rate	$T_{amb}$	-	-40	+125	°C
	$\Delta t/\Delta V$	$V_{CCI}=1.2V^{[2]}$	-	20	ns/V
		$V_{CCI}=1.4V$ to $1.95V$	-	20	ns/V
		$V_{CCI}=2.3V$ to $2.7V$	-	20	ns/V
		$V_{CCI}=3V$ to $3.6V$	-	10	ns/V
		$V_{CCI}=4.5V$ to $5.5V$	-	5	ns/V

Note:

[1]  $V_{CCO}$  is the supply voltage associated with the output port.

[2]  $V_{CCI}$  is the supply voltage associated with the input port.

### 3.3. Electrical Characteristics

#### 3.3.1. DC Characteristics 1

( $T_{amb}=25^\circ C$ , voltages are referenced to GND (ground=0V), unless otherwise specified)

Parameter	Symbol	Conditions	Min.	Typ.	Max.	Unit
HIGH-level output voltage	$V_{OH}$	$V_I=V_{IH}$ or $V_{IL}$ ; $I_O=-3mA$ ; $V_{CCO}=1.2V^{[1]}$	-	1.09	-	V
LOW-level output voltage	$V_{OL}$	$V_I=V_{IH}$ or $V_{IL}$ ; $I_O=3mA$ ; $V_{CCO}=1.2V^{[1]}$	-	0.07	-	V
input leakage current	$I_I$	DIR input; $V_I=0V$ to $5.5V$ ; $V_{CCI}=1.2V$ to $5.5V^{[2]}$	-	-	$\pm 1$	$\mu A$
bus hold LOW current	$I_{BHL}$	A or B port; $V_I=0.42V$ ; $V_{CCI}=1.2V^{[2]}$	-	19	-	$\mu A$
bus hold HIGH current	$I_{BHH}$	A or B port; $V_I=0.78V$ ; $V_{CCI}=1.2V^{[2]}$	-	-19	-	$\mu A$
bus hold LOW overdrive current	$I_{BHLO}$	A or B port; $V_{CCI}=1.2V^{[2][3]}$	-	19	-	$\mu A$
bus hold HIGH overdrive current	$I_{BHHO}$	A or B port; $V_{CCI}=1.2V^{[2][3]}$	-	-19	-	$\mu A$
OFF-state output current	$I_{OZ}$	A or B port; $V_O=0V$ or $V_{CCO}$ ; $V_{CCO}=1.2V$ to $5.5V^{[1]}$	-	-	$\pm 1$	$\mu A$
power-off leakage current	$I_{OFF}$	A port; $V_I$ or $V_O=0V$ to $5.5V$ ; $V_{CC(A)}=0V$ ; $V_{CC(B)}=1.2V$ to $5.5V$	-	-	$\pm 1$	$\mu A$
		B port; $V_I$ or $V_O=0V$ to $5.5V$ ; $V_{CC(B)}=0V$ ; $V_{CC(A)}=1.2V$ to $5.5V$	-	-	$\pm 1$	$\mu A$
input capacitance	$C_I$	DIR input; $V_I=0V$ or $3.3V$ ; $V_{CC(A)}=V_{CC(B)}=3.3V$	-	2.2	-	pF
input/output capacitance	$C_{I/O}$	A and B port; suspend mode; $V_O=3.3V$ or $0V$ ; $V_{CC(A)}=V_{CC(B)}=3.3V$	-	6.0	-	pF



Note:

[1]  $V_{CCO}$  is the supply voltage associated with the output port.

[2]  $V_{CCI}$  is the supply voltage associated with the data input port.

[3] To guarantee the node switches, an external driver must source/sink at least  $I_{BHLO}/I_{BHHO}$  when the input is in the range  $V_{IL}$  to  $V_{IH}$ .

### 3.3.2、DC Characteristics 2

( $T_{amb}=-40^{\circ}\text{C}$  to  $+85^{\circ}\text{C}$ , voltages are referenced to GND (ground=0V), unless otherwise specified)

Parameter	Symbol	Conditions	Min.	Typ.	Max.	Unit	
HIGH-level input voltage	$V_{IH}$	data input <sup>[1]</sup>	$V_{CCI}=1.2\text{V}$	$0.8V_{CCI}$	-	-	V
			$V_{CCI}=1.4\text{V}$ to $1.95\text{V}$	$0.65V_{CCI}$	-	-	V
			$V_{CCI}=2.3\text{V}$ to $2.7\text{V}$	1.7	-	-	V
			$V_{CCI}=3.0\text{V}$ to $3.6\text{V}$	2.0	-	-	V
			$V_{CCI}=4.5\text{V}$ to $5.5\text{V}$	$0.7V_{CCI}$	-	-	V
		DIR input	$V_{CCI}=1.2\text{V}$	$0.8V_{CC(A)}$	-	-	V
			$V_{CCI}=1.4\text{V}$ to $1.95\text{V}$	$0.65V_{CC(A)}$	-	-	V
			$V_{CCI}=2.3\text{V}$ to $2.7\text{V}$	1.7	-	-	V
			$V_{CCI}=3.0\text{V}$ to $3.6\text{V}$	2.0	-	-	V
			$V_{CCI}=4.5\text{V}$ to $5.5\text{V}$	$0.7V_{CC(A)}$	-	-	V
LOW-level input voltage	$V_{IL}$	data input <sup>[1]</sup>	$V_{CCI}=1.2\text{V}$	-	-	$0.2V_{CCI}$	V
			$V_{CCI}=1.4\text{V}$ to $1.95\text{V}$	-	-	$0.35V_{CCI}$	V
			$V_{CCI}=2.3\text{V}$ to $2.7\text{V}$	-	-	0.7	V
			$V_{CCI}=3.0\text{V}$ to $3.6\text{V}$	-	-	0.8	V
			$V_{CCI}=4.5\text{V}$ to $5.5\text{V}$	-	-	$0.3V_{CCI}$	V
		DIR input	$V_{CCI}=1.2\text{V}$	-	-	$0.2V_{CC(A)}$	V
			$V_{CCI}=1.4\text{V}$ to $1.95\text{V}$	-	-	$0.35V_{CC(A)}$	V
			$V_{CCI}=2.3\text{V}$ to $2.7\text{V}$	-	-	0.7	V
			$V_{CCI}=3.0\text{V}$ to $3.6\text{V}$	-	-	0.8	V
			$V_{CCI}=4.5\text{V}$ to $5.5\text{V}$	-	-	$0.3V_{CC(A)}$	V
HIGH-level output voltage	$V_{OH}$	$V_I=V_{IH}$	$I_O=-100\mu\text{A}; V_{CCO}=1.2\text{V}$ to $4.5\text{V}^{[2]}$	$V_{CCO}-0.1$	-	-	V
			$I_O=-6\text{mA}; V_{CCO}=1.4\text{V}$	1.0	-	-	V
			$I_O=-8\text{mA}; V_{CCO}=1.65\text{V}$	1.2	-	-	V
			$I_O=-12\text{mA}; V_{CCO}=2.3\text{V}$	1.9	-	-	V
			$I_O=-24\text{mA}; V_{CCO}=3.0\text{V}$	2.4	-	-	V
			$I_O=-32\text{mA}; V_{CCO}=4.5\text{V}$	3.8	-	-	V
LOW-level output voltage	$V_{OL}$	$V_I=V_{IH}^{[2]}$	$I_O=100\mu\text{A}; V_{CCO}=1.2\text{V}$ to $4.5\text{V}$	-	-	0.1	V
			$I_O=6\text{mA}; V_{CCO}=1.4\text{V}$	-	-	0.3	V
			$I_O=8\text{mA}; V_{CCO}=1.65\text{V}$	-	-	0.45	V
			$I_O=12\text{mA}; V_{CCO}=2.3\text{V}$	-	-	0.3	V
			$I_O=24\text{mA}; V_{CCO}=3.0\text{V}$	-	-	0.55	V
			$I_O=32\text{mA}; V_{CCO}=4.5\text{V}$	-	-	0.55	V
input leakage current	$I_I$	DIR input; $V_I=0\text{V}$ to $5.5\text{V}; V_{CCI}=1.2\text{V}$ to $5.5\text{V}$	-	-	$\pm 2$	$\mu\text{A}$	





bus hold LOW current	$I_{BHL}$	A or B port <sup>[1]</sup>	$V_I=0.49V; V_{CCI}=1.4V$	15	-	-	uA
			$V_I=0.58V; V_{CCI}=1.65V$	25	-	-	uA
			$V_I=0.70V; V_{CCI}=2.3V$	45	-	-	uA
			$V_I=0.80V; V_{CCI}=3.0V$	100	-	-	uA
			$V_I=1.35V; V_{CCI}=4.5V$	100	-	-	uA
bus hold HIGH current	$I_{BHH}$	A or B port <sup>[1]</sup>	$V_I=0.91V; V_{CCI}=1.4V$	-15	-	-	uA
			$V_I=1.07V; V_{CCI}=1.65V$	-25	-	-	uA
			$V_I=1.60V; V_{CCI}=2.3V$	-45	-	-	uA
			$V_I=2.00V; V_{CCI}=3.0V$	-100	-	-	uA
			$V_I=3.15V; V_{CCI}=4.5V$	-100	-	-	uA
bus hold LOW overdrive current	$I_{BHLO}$	A or B port <sup>[1][3]</sup>	$V_{CCI}=1.6V$	125	-	-	uA
			$V_{CCI}=1.95V$	200	-	-	uA
			$V_{CCI}=2.7V$	300	-	-	uA
			$V_{CCI}=3.6V$	500	-	-	uA
			$V_{CCI}=5.5V$	900	-	-	uA
bus hold HIGH overdrive current	$I_{BHHO}$	A or B port <sup>[1][3]</sup>	$V_{CCI}=1.6V$	-125	-	-	uA
			$V_{CCI}=1.95V$	-200	-	-	uA
			$V_{CCI}=2.7V$	-300	-	-	uA
			$V_{CCI}=3.6V$	-500	-	-	uA
			$V_{CCI}=5.5V$	-900	-	-	uA
OFF-state output	$I_{OZ}$	A or B port; $V_O=0V$ or $V_{CCO}$ ; $V_{CCO}=1.2V$ to $5.5V$ <sup>[2]</sup>		-	-	$\pm 2$	uA
power-off leakage current	$I_{OFF}$	A port; $V_I$ or $V_O=0V$ to $5.5V$ ; $V_{CC(A)}=0V$ ; $V_{CC(B)}=1.2V$ to $5.5V$		-	-	$\pm 2$	uA
		B port; $V_I$ or $V_O=0V$ to $5.5V$ ; $V_{CC(B)}=0V$ ; $V_{CC(A)}=1.2V$ to $5.5V$		-	-	$\pm 2$	uA
supply current	$I_{CC}$	A port; $V_I=0V$ or $V_{CCI}$ ; $I_O=0A$ <sup>[1]</sup>	$V_{CC(A)}, V_{CC(B)}=1.2V$ to $5.5V$	-	-	8	uA
			$V_{CC(A)}, V_{CC(B)}=1.65V$ to $5.5V$	-	-	3	uA
			$V_{CC(A)}=5.5V; V_{CC(B)}=0V$	-	-	2	uA
			$V_{CC(A)}=0V; V_{CC(B)}=5.5V$	-2	-	-	uA
		B port; $V_I=0V$ or $V_{CCI}$ ; $I_O=0A$	$V_{CC(A)}, V_{CC(B)}=1.2V$ to $5.5V$	-	-	8	uA
			$V_{CC(A)}, V_{CC(B)}=1.65V$ to $5.5V$	-	-	3	uA
			$V_{CC(B)}=0V; V_{CC(A)}=5.5V$	-2	-	-	uA
			$V_{CC(B)}=5.5V; V_{CC(A)}=0V$	-	-	2	uA
		A plus B port ( $I_{CC(A)}+I_{CC(B)}$ ); $I_O=0A$ ; $V_I=0V$ or $V_{CCI}$	$V_{CC(A)}, V_{CC(B)}=1.2V$ to $5.5V$	-	-	16	uA
$V_{CC(A)}, V_{CC(B)}=1.65V$ to $5.5V$	-		-	4	uA		
additional supply current	$\Delta I_{CC}$	per input; $V_{CC(A)}, V_{CC(B)}=$ $3.0V$ to $5.5V$	A port; A port at $V_{CC(A)}-0.6V$ ; DIR at $V_{CC(A)}$ ; B port=open <sup>[4]</sup>	-	-	50	uA
			DIR input; DIR at $V_{CC(A)}-0.6V$ ; A port at $V_{CC(A)}$ or GND; B port=open	-	-	50	uA
			B port; B port at $V_{CC(B)}-0.6V$ ; DIR at GND; A port=open <sup>[4]</sup>	-	-	50	uA



Note:

- [1]  $V_{CCI}$  is the supply voltage associated with the data input port.
- [2]  $V_{CCO}$  is the supply voltage associated with the output port.
- [3] To guarantee the node switches, an external driver must source/sink at least  $I_{BHLO}/I_{BHHO}$  when the input is in the range  $V_{IL}$  to  $V_{IH}$ .
- [4] For non bus hold parts only (SN74LVC1T45).

### 3.3.3、DC Characteristics 3

( $T_{amb}=-40^{\circ}\text{C}$  to  $+125^{\circ}\text{C}$ , voltages are referenced to GND (ground=0V), unless otherwise specified)

Parameter	Symbol	Conditions	Min.	Typ.	Max.	Unit	
HIGH-level input voltage	$V_{IH}$	data input <sup>[1]</sup>	$V_{CCI}=1.2\text{V}$	$0.8V_{CCI}$	-	-	V
			$V_{CCI}=1.4\text{V}$ to $1.95\text{V}$	$0.65V_{CCI}$	-	-	V
			$V_{CCI}=2.3\text{V}$ to $2.7\text{V}$	1.7	-	-	V
			$V_{CCI}=3.0\text{V}$ to $3.6\text{V}$	2.0	-	-	V
			$V_{CCI}=4.5\text{V}$ to $5.5\text{V}$	$0.7V_{CCI}$	-	-	V
		DIR input	$V_{CCI}=1.2\text{V}$	$0.8V_{CC(A)}$	-	-	V
			$V_{CCI}=1.4\text{V}$ to $1.95\text{V}$	$0.65V_{CC(A)}$	-	-	V
			$V_{CCI}=2.3\text{V}$ to $2.7\text{V}$	1.7	-	-	V
			$V_{CCI}=3.0\text{V}$ to $3.6\text{V}$	2.0	-	-	V
			$V_{CCI}=4.5\text{V}$ to $5.5\text{V}$	$0.7V_{CC(A)}$	-	-	V
LOW-level input voltage	$V_{IL}$	data input <sup>[1]</sup>	$V_{CCI}=1.2\text{V}$	-	-	$0.2V_{CCI}$	V
			$V_{CCI}=1.4\text{V}$ to $1.95\text{V}$	-	-	$0.35V_{CCI}$	V
			$V_{CCI}=2.3\text{V}$ to $2.7\text{V}$	-	-	0.7	V
			$V_{CCI}=3.0\text{V}$ to $3.6\text{V}$	-	-	0.8	V
			$V_{CCI}=4.5\text{V}$ to $5.5\text{V}$	-	-	$0.3V_{CCI}$	V
		DIR input	$V_{CCI}=1.2\text{V}$	-	-	$0.2V_{CC(A)}$	V
			$V_{CCI}=1.4\text{V}$ to $1.95\text{V}$	-	-	$0.35V_{CC(A)}$	V
			$V_{CCI}=2.3\text{V}$ to $2.7\text{V}$	-	-	0.7	V
			$V_{CCI}=3.0\text{V}$ to $3.6\text{V}$	-	-	0.8	V
			$V_{CCI}=4.5\text{V}$ to $5.5\text{V}$	-	-	$0.3V_{CC(A)}$	V
HIGH-level output voltage	$V_{OH}$	$V_I=V_{IH}$	$I_O=-100\mu\text{A}; V_{CCO}=1.2\text{V}$ to $4.5\text{V}^{[2]}$	$V_{CCO}-0.1$	-	-	V
			$I_O=-6\text{mA}; V_{CCO}=1.4\text{V}$	1.0	-	-	V
			$I_O=-8\text{mA}; V_{CCO}=1.65\text{V}$	1.2	-	-	V
			$I_O=-12\text{mA}; V_{CCO}=2.3\text{V}$	1.9	-	-	V
			$I_O=-24\text{mA}; V_{CCO}=3.0\text{V}$	2.4	-	-	V
			$I_O=-32\text{mA}; V_{CCO}=4.5\text{V}$	3.8	-	-	V
LOW-level output voltage	$V_{OL}$	$V_I=V_{IH}^{[2]}$	$I_O=100\mu\text{A}; V_{CCO}=1.2\text{V}$ to $4.5\text{V}$	-	-	0.1	V
			$I_O=6\text{mA}; V_{CCO}=1.4\text{V}$	-	-	0.3	V
			$I_O=8\text{mA}; V_{CCO}=1.65\text{V}$	-	-	0.45	V
			$I_O=12\text{mA}; V_{CCO}=2.3\text{V}$	-	-	0.3	V
			$I_O=24\text{mA}; V_{CCO}=3.0\text{V}$	-	-	0.55	V
			$I_O=32\text{mA}; V_{CCO}=4.5\text{V}$	-	-	0.55	V



input leakage current	$I_I$	DIR input; $V_I=0V$ to $5.5V$ ; $V_{CC1}=1.2V$ to $5.5V$	-	-	$\pm 2$	$\mu A$	
bus hold LOW current	$I_{BHL}$	A or B port <sup>[1]</sup>	$V_I=0.49V$ ; $V_{CC1}=1.4V$	10	-	-	$\mu A$
			$V_I=0.58V$ ; $V_{CC1}=1.65V$	20	-	-	$\mu A$
			$V_I=0.70V$ ; $V_{CC1}=2.3V$	45	-	-	$\mu A$
			$V_I=0.80V$ ; $V_{CC1}=3.0V$	80	-	-	$\mu A$
			$V_I=1.35V$ ; $V_{CC1}=4.5V$	100	-	-	$\mu A$
bus hold HIGH current	$I_{BHH}$	A or B port <sup>[1]</sup>	$V_I=0.91V$ ; $V_{CC1}=1.4V$	-10	-	-	$\mu A$
			$V_I=1.07V$ ; $V_{CC1}=1.65V$	-20	-	-	$\mu A$
			$V_I=1.60V$ ; $V_{CC1}=2.3V$	-45	-	-	$\mu A$
			$V_I=2.00V$ ; $V_{CC1}=3.0V$	-80	-	-	$\mu A$
			$V_I=3.15V$ ; $V_{CC1}=4.5V$	-100	-	-	$\mu A$
bus hold LOW overdrive current	$I_{BHLO}$	A or B port <sup>[1][3]</sup>	$V_{CC1}=1.6V$	125	-	-	$\mu A$
			$V_{CC1}=1.95V$	200	-	-	$\mu A$
			$V_{CC1}=2.7V$	300	-	-	$\mu A$
			$V_{CC1}=3.6V$	500	-	-	$\mu A$
			$V_{CC1}=5.5V$	900	-	-	$\mu A$
bus hold HIGH overdrive current	$I_{BHHO}$	A or B port <sup>[1][3]</sup>	$V_{CC1}=1.6V$	-125	-	-	$\mu A$
			$V_{CC1}=1.95V$	-200	-	-	$\mu A$
			$V_{CC1}=2.7V$	-300	-	-	$\mu A$
			$V_{CC1}=3.6V$	-500	-	-	$\mu A$
			$V_{CC1}=5.5V$	-900	-	-	$\mu A$
OFF-state output	$I_{OZ}$	A or B port; $V_O=0V$ or $V_{CCO}$ ; $V_{CCO}=1.2V$ to $5.5V$ <sup>[2]</sup>	-	-	$\pm 10$	$\mu A$	
power-off leakage current	$I_{OFF}$	A port; $V_I$ or $V_O=0V$ to $5.5V$ ; $V_{CC(A)}=0V$ ; $V_{CC(B)}=1.2V$ to $5.5V$	-	-	$\pm 10$	$\mu A$	
		B port; $V_I$ or $V_O=0V$ to $5.5V$ ; $V_{CC(B)}=0V$ ; $V_{CC(A)}=1.2V$ to $5.5V$	-	-	$\pm 10$	$\mu A$	
supply current	$I_{CC}$	A port; $V_I=0V$ or $V_{CC1}$ ; $I_O=0A$ <sup>[1]</sup>	$V_{CC(A)}, V_{CC(B)}=1.2V$ to $5.5V$	-	-	8	$\mu A$
			$V_{CC(A)}, V_{CC(B)}=1.65V$ to $5.5V$	-	-	3	$\mu A$
			$V_{CC(A)}=5.5V$ ; $V_{CC(B)}=0V$	-	-	2	$\mu A$
			$V_{CC(A)}=0V$ ; $V_{CC(B)}=5.5V$	-2	-	-	$\mu A$
		B port; $V_I=0V$ or $V_{CC1}$ ; $I_O=0A$	$V_{CC(A)}, V_{CC(B)}=1.2V$ to $5.5V$	-	-	8	$\mu A$
			$V_{CC(A)}, V_{CC(B)}=1.65V$ to $5.5V$	-	-	3	$\mu A$
			$V_{CC(B)}=0V$ ; $V_{CC(A)}=5.5V$	-2	-	-	$\mu A$
			$V_{CC(B)}=5.5V$ ; $V_{CC(A)}=0V$	-	-	2	$\mu A$
		A plus B port ( $I_{CC(A)}+I_{CC(B)}$ ); $I_O=0A$ ; $V_I=0V$ or $V_{CC1}$	$V_{CC(A)}, V_{CC(B)}=1.2V$ to $5.5V$	-	-	16	$\mu A$
			$V_{CC(A)}, V_{CC(B)}=1.65V$ to $5.5V$	-	-	4	$\mu A$
additional supply current	$\Delta I_{CC}$	per input; $V_{CC(A)}, V_{CC(B)}=3.0V$ to $5.5V$	A port; A port at $V_{CC(A)}-0.6V$ ; DIR at $V_{CC(A)}$ ; B port=open <sup>[4]</sup>	-	-	75	$\mu A$
		DIR input; DIR at $V_{CC(A)}-0.6V$ ; A port at $V_{CC(A)}$ or GND; B port=open	-	-	75	$\mu A$	



			B port; B port at $V_{CC(B)}-0.6V$ ; DIR at GND; A port=open <sup>[4]</sup>	-	-	75	uA
--	--	--	--	---	---	----	----

Note:

[1]  $V_{CCI}$  is the supply voltage associated with the data input port.

[2]  $V_{CCO}$  is the supply voltage associated with the output port.

[3] To guarantee the node switches, an external driver must source/sink at least  $I_{BHLO}/I_{BHHO}$  when the input is in the range  $V_{IL}$  to  $V_{IH}$ .

[4] For non bus hold parts only (SN74LVC1T45).

### 3.3.4、AC Characteristics 1

( $T_{amb}=-40^{\circ}C$  to  $+85^{\circ}C$ , voltages are referenced to GND (ground=0V), unless otherwise specified)

Parameter	Symbol	Conditions	$V_{CC(B)}$										Unit
			1.5V±0.1V		1.8V±0.15V		2.5V±0.2V		3.3V±0.3V		5.0V±0.5V		
			Min.	Max.	Min.	Max.	Min.	Max.	Min.	Max.	Min.	Max.	
$V_{CC(A)}=1.4V$ to $1.6V$													
LOW to HIGH propagation delay	$t_{PLH}$	A to B	-	22.0	-	18.2	-	13.7	-	12.0	-	10.7	ns
		B to A	-	22.0	-	19.5	-	16.2	-	15.9	-	15.5	ns
HIGH to LOW propagation delay	$t_{PHL}$	A to B	-	19.7	-	15.6	-	12.1	-	11.1	-	10.8	ns
		B to A	-	19.7	-	17.6	-	13.5	-	11.5	-	11.2	ns
HIGH to OFF-state propagation delay	$t_{PHZ}$	DIR to A	-	19.2	-	19.2	-	19.2	-	19.2	-	19.2	ns
		DIR to B	-	25.0	-	23.8	-	14.1	-	13.2	-	12.5	ns
LOW to OFF-state propagation delay	$t_{PLZ}$	DIR to A	-	11.7	-	11.7	-	11.7	-	11.7	-	11.7	ns
		DIR to B	-	18.5	-	17.5	-	13.2	-	12.4	-	11.6	ns
OFF-state to HIGH propagation delay	$t_{PZH}$	DIR to A <sup>[1]</sup>	-	39.7	-	36.7	-	24.8	-	23.0	-	21.8	ns
		DIR to B <sup>[1]</sup>	-	33.0	-	29.5	-	25.3	-	23.3	-	22.3	ns
OFF-state to LOW propagation delay	$t_{PZL}$	DIR to A <sup>[1]</sup>	-	44.5	-	41.2	-	24.6	-	22.9	-	21.6	ns
		DIR to B <sup>[1]</sup>	-	38.3	-	34.7	-	31.1	-	30.2	-	29.8	ns
$V_{CC(A)}=1.65V$ to $1.95V$													
LOW to HIGH propagation delay	$t_{PLH}$	A to B	-	19.5	-	18.1	-	9.7	-	7.7	-	7.2	ns
		B to A	-	18.3	-	18.1	-	15.2	-	12.6	-	12.2	ns
HIGH to LOW propagation delay	$t_{PHL}$	A to B	-	17.4	-	14.4	-	9.0	-	7.5	-	7.3	ns
		B to A	-	15.6	-	14.4	-	13.2	-	12.9	-	12.5	ns
HIGH to	$t_{PHZ}$	DIR to A	-	17.5	-	17.5	-	17.5	-	17.5	-	17.5	ns



OFF-state propagation delay		DIR to B	-	24.5	-	22.3	-	12.8	-	12.0	-	10.5	ns
LOW to OFF-state propagation delay	$t_{PLZ}$	DIR to A	-	11.1	-	11.1	-	11.1	-	11.1	-	11.1	ns
		DIR to B	-	18.4	-	16.9	-	11.3	-	10.5	-	9.5	ns
OFF-state to HIGH propagation delay	$t_{PZH}$	DIR to A <sup>[1]</sup>	-	35.6	-	33.9	-	25.6	-	24.4	-	22.3	ns
		DIR to B <sup>[1]</sup>	-	30.0	-	28.5	-	20.3	-	18.1	-	17.5	ns
OFF-state to LOW propagation delay	$t_{PZL}$	DIR to A <sup>[1]</sup>	-	39.8	-	36.5	-	24.8	-	23.3	-	20.6	ns
		DIR to B <sup>[1]</sup>	-	35.0	-	31.9	-	26.0	-	24.6	-	24.5	ns
<b><math>V_{CC(A)}=2.3V</math> to <math>2.7V</math></b>													
LOW to HIGH propagation delay	$t_{PLH}$	A to B	-	18.1	-	16.1	-	8.7	-	6.5	-	5.0	ns
		B to A	-	13.7	-	9.2	-	8.7	-	7.8	-	7.5	ns
HIGH to LOW propagation delay	$t_{PHL}$	A to B	-	15.9	-	13.2	-	7.6	-	5.9	-	4.9	ns
		B to A	-	12.3	-	8.7	-	7.6	-	7.0	-	6.2	ns
HIGH to OFF-state propagation delay	$t_{PHZ}$	DIR to A	-	8.2	-	8.2	-	8.2	-	8.2	-	8.2	ns
		DIR to B	-	22.5	-	21.6	-	11.2	-	9.2	-	8.3	ns
LOW to OFF-state propagation delay	$t_{PLZ}$	DIR to A	-	6.2	-	6.2	-	6.2	-	6.2	-	6.2	ns
		DIR to B	-	14.6	-	13.3	-	9.2	-	8.7	-	7.7	ns
OFF-state to HIGH propagation delay	$t_{PZH}$	DIR to A <sup>[1]</sup>	-	27.7	-	22.3	-	17.2	-	16.5	-	12.6	ns
		DIR to B <sup>[1]</sup>	-	23.5	-	21.5	-	14.1	-	11.9	-	10.5	ns
OFF-state to LOW propagation delay	$t_{PZL}$	DIR to A <sup>[1]</sup>	-	34.1	-	29.5	-	18.3	-	16.2	-	13.0	ns
		DIR to B <sup>[1]</sup>	-	23.7	-	20.9	-	15.5	-	13.5	-	12.5	ns
<b><math>V_{CC(A)}=3.0V</math> to <math>3.6V</math></b>													
LOW to HIGH propagation delay	$t_{PLH}$	A to B	-	17.2	-	15.5	-	7.9	-	5.6	-	4.5	ns
		B to A	-	11.7	-	7.3	-	6.4	-	5.6	-	5.5	ns
HIGH to LOW propagation delay	$t_{PHL}$	A to B	-	15.5	-	12.5	-	7.0	-	5.0	-	4.4	ns
		B to A	-	11.0	-	7.2	-	5.6	-	5.0	-	4.5	ns
HIGH to OFF-state propagation delay	$t_{PHZ}$	DIR to A	-	7.3	-	7.3	-	7.3	-	7.3	-	7.3	ns
		DIR to B	-	18.1	-	16.6	-	10.4	-	8.7	-	6.8	ns



LOW to OFF-state propagation delay	$t_{PLZ}$	DIR to A	-	5.8	-	5.8	-	5.8	-	5.8	-	5.8	ns
		DIR to B	-	13.8	-	12.7	-	8.0	-	7.4	-	6.8	ns
OFF-state to HIGH propagation delay	$t_{PZH}$	DIR to A <sup>[1]</sup>	-	25.0	-	19.4	-	13.8	-	12.6	-	10.0	ns
		DIR to B <sup>[1]</sup>	-	22.5	-	20.7	-	13.3	-	10.9	-	9.8	ns
OFF-state to LOW propagation delay	$t_{PZL}$	DIR to A <sup>[1]</sup>	-	28.5	-	23.3	-	15.3	-	13.3	-	10.5	ns
		DIR to B <sup>[1]</sup>	-	22.7	-	19.7	-	14.1	-	12.1	-	11.1	ns
<b><math>V_{CC(A)}=4.5V</math> to <math>5.5V</math></b>													
LOW to HIGH propagation delay	$t_{PLH}$	A to B	-	16.5	-	15.0	-	7.7	-	5.6	-	3.9	ns
		B to A	-	10.4	-	6.6	-	5.0	-	4.5	-	3.9	ns
HIGH to LOW propagation delay	$t_{PHL}$	A to B	-	15.0	-	12.1	-	6.3	-	4.5	-	3.6	ns
		B to A	-	10.4	-	6.5	-	4.6	-	4.0	-	3.6	ns
HIGH to OFF-state propagation delay	$t_{PHZ}$	DIR to A	-	5.5	-	5.5	-	5.5	-	5.5	-	5.5	ns
		DIR to B	-	16.9	-	15.9	-	9.5	-	8.0	-	6.5	ns
LOW to OFF-state propagation delay	$t_{PLZ}$	DIR to A	-	5.3	-	5.3	-	5.3	-	5.3	-	5.3	ns
		DIR to B	-	13.0	-	11.8	-	7.5	-	7.1	-	6.5	ns
OFF-state to HIGH propagation delay	$t_{PZH}$	DIR to A <sup>[1]</sup>	-	23.5	-	18.7	-	12.0	-	10.9	-	8.3	ns
		DIR to B <sup>[1]</sup>	-	20.0	-	18.6	-	11.0	-	9.1	-	7.4	ns
OFF-state to LOW propagation delay	$t_{PZL}$	DIR to A <sup>[1]</sup>	-	27.7	-	23.3	-	14.1	-	11.6	-	9.3	ns
		DIR to B <sup>[1]</sup>	-	20.5	-	17.7	-	11.3	-	9.6	-	8.9	ns

Note: [1]  $t_{PZH}$  and  $t_{PZL}$  are calculated values using the formula shown in Section 6.4.



### 3.3.5、AC Characteristics 2

( $T_{amb} = -40^{\circ}\text{C}$  to  $+125^{\circ}\text{C}$ , voltages are referenced to GND (ground=0V), unless otherwise specified)

Parameter	Symbol	Conditions	$V_{CC(B)}$										Unit
			1.5V±0.1V		1.8V±0.15V		2.5V±0.2V		3.3V±0.3V		5.0V±0.5V		
			Min.	Max.	Min.	Max.	Min.	Max.	Min.	Max.	Min.	Max.	
$V_{CC(A)} = 1.4\text{V to } 1.6\text{V}$													
LOW to HIGH propagation delay	$t_{PLH}$	A to B	-	24.2	-	20.0	-	15.1	-	13.2	-	11.8	ns
		B to A	-	24.2	-	21.4	-	17.8	-	17.5	-	17.1	ns
HIGH to LOW propagation delay	$t_{PHL}$	A to B	-	21.7	-	17.2	-	13.3	-	12.2	-	11.9	ns
		B to A	-	21.7	-	19.4	-	14.9	-	12.7	-	12.3	ns
HIGH to OFF-state propagation delay	$t_{PHZ}$	DIR to A	-	21.1	-	21.1	-	21.1	-	21.1	-	21.1	ns
		DIR to B	-	27.5	-	26.2	-	15.5	-	14.5	-	13.8	ns
LOW to OFF-state propagation delay	$t_{PLZ}$	DIR to A	-	12.9	-	12.9	-	12.9	-	12.9	-	12.9	ns
		DIR to B	-	20.4	-	19.3	-	14.5	-	13.6	-	12.8	ns
OFF-state to HIGH propagation delay	$t_{PZH}$	DIR to A <sup>[1]</sup>	-	43.7	-	40.4	-	27.3	-	25.3	-	24.0	ns
		DIR to B <sup>[1]</sup>	-	36.3	-	32.4	-	27.8	-	25.6	-	24.5	ns
OFF-state to LOW propagation delay	$t_{PZL}$	DIR to A <sup>[1]</sup>	-	48.9	-	45.3	-	27.1	-	25.2	-	23.8	ns
		DIR to B <sup>[1]</sup>	-	42.1	-	38.2	-	34.2	-	33.2	-	32.8	ns
$V_{CC(A)} = 1.65\text{V to } 1.95\text{V}$													
LOW to HIGH propagation delay	$t_{PLH}$	A to B	-	21.4	-	19.9	-	10.7	-	8.5	-	7.9	ns
		B to A	-	20.1	-	19.9	-	16.7	-	13.9	-	13.4	ns
HIGH to LOW propagation delay	$t_{PHL}$	A to B	-	19.1	-	15.8	-	9.9	-	8.3	-	8.0	ns
		B to A	-	17.2	-	15.8	-	14.5	-	14.2	-	13.7	ns
HIGH to OFF-state propagation delay	$t_{PHZ}$	DIR to A	-	19.2	-	19.2	-	19.2	-	19.2	-	19.2	ns
		DIR to B	-	26.9	-	24.5	-	14.1	-	13.2	-	11.5	ns
LOW to OFF-state propagation delay	$t_{PLZ}$	DIR to A	-	12.2	-	12.2	-	12.2	-	12.2	-	12.2	ns
		DIR to B	-	20.2	-	18.6	-	12.4	-	11.5	-	10.4	ns
OFF-state to HIGH propagation delay	$t_{PZH}$	DIR to A <sup>[1]</sup>	-	39.2	-	37.3	-	28.2	-	26.8	-	24.5	ns
		DIR to B <sup>[1]</sup>	-	33.0	-	31.4	-	22.3	-	19.9	-	19.3	ns
OFF-state to	$t_{PZL}$	DIR to A <sup>[1]</sup>	-	43.8	-	40.2	-	27.3	-	25.6	-	22.7	ns



LOW propagation delay		DIR to B <sup>[1]</sup>	-	38.5	-	35.1	-	28.6	-	27.1	-	26.9	ns
<b>V<sub>CC(A)</sub>=2.3V to 2.7V</b>													
LOW to HIGH propagation delay	t <sub>PLH</sub>	A to B	-	19.9	-	17.7	-	9.6	-	7.1	-	5.5	ns
		B to A	-	15.1	-	10.1	-	9.6	-	8.6	-	8.3	ns
HIGH to LOW propagation delay	t <sub>PHL</sub>	A to B	-	17.5	-	14.5	-	8.4	-	6.5	-	5.4	ns
		B to A	-	13.5	-	9.6	-	8.4	-	7.7	-	6.8	ns
HIGH to OFF-state propagation delay	t <sub>PHZ</sub>	DIR to A	-	9.0	-	9.0	-	9.0	-	9.0	-	9.0	ns
		DIR to B	-	24.8	-	23.8	-	12.3	-	10.1	-	9.1	ns
LOW to OFF-state propagation delay	t <sub>PLZ</sub>	DIR to A	-	6.8	-	6.8	-	6.8	-	6.8	-	6.8	ns
		DIR to B	-	16.1	-	14.6	-	10.1	-	9.6	-	8.5	ns
OFF-state to HIGH propagation delay	t <sub>PZH</sub>	DIR to A <sup>[1]</sup>	-	30.5	-	24.5	-	18.9	-	18.1	-	13.9	ns
		DIR to B <sup>[1]</sup>	-	25.8	-	23.7	-	15.5	-	13.1	-	11.5	ns
OFF-state to LOW propagation delay	t <sub>PZL</sub>	DIR to A <sup>[1]</sup>	-	37.5	-	32.5	-	20.1	-	17.8	-	14.3	ns
		DIR to B <sup>[1]</sup>	-	26.1	-	23.0	-	17.0	-	14.8	-	13.8	ns
<b>V<sub>CC(A)</sub>=3.0V to 3.6V</b>													
LOW to HIGH propagation delay	t <sub>PLH</sub>	A to B	-	18.9	-	17.0	-	8.7	-	6.2	-	4.9	ns
		B to A	-	12.9	-	8.0	-	7.0	-	6.2	-	6.0	ns
HIGH to LOW propagation delay	t <sub>PHL</sub>	A to B	-	17.1	-	13.8	-	7.7	-	5.5	-	4.8	ns
		B to A	-	12.1	-	7.9	-	6.2	-	5.5	-	5.0	ns
HIGH to OFF-state propagation delay	t <sub>PHZ</sub>	DIR to A	-	8.0	-	8.0	-	8.0	-	8.0	-	8.0	ns
		DIR to B	-	19.9	-	18.3	-	11.4	-	9.6	-	7.5	ns
LOW to OFF-state propagation delay	t <sub>PLZ</sub>	DIR to A	-	6.4	-	6.4	-	6.4	-	6.4	-	6.4	ns
		DIR to B	-	15.2	-	14.0	-	8.8	-	8.1	-	7.5	ns
OFF-state to HIGH propagation delay	t <sub>PZH</sub>	DIR to A <sup>[1]</sup>	-	27.5	-	21.3	-	15.2	-	13.9	-	11.0	ns
		DIR to B <sup>[1]</sup>	-	24.8	-	22.8	-	14.6	-	12.0	-	10.8	ns
OFF-state to LOW propagation delay	t <sub>PZL</sub>	DIR to A <sup>[1]</sup>	-	31.3	-	25.6	-	16.8	-	14.6	-	11.6	ns
		DIR to B <sup>[1]</sup>	-	25.0	-	21.7	-	15.5	-	13.3	-	12.2	ns
<b>V<sub>CC(A)</sub>=4.5V to 5.5V</b>													





LOW to HIGH propagation delay	$t_{PLH}$	A to B	-	18.1	-	16.5	-	8.5	-	6.2	-	4.3	ns
		B to A	-	11.4	-	7.3	-	5.5	-	5.0	-	4.3	ns
HIGH to LOW propagation delay	$t_{PHL}$	A to B	-	16.5	-	13.3	-	6.9	-	5.0	-	4.0	ns
		B to A	-	11.4	-	7.1	-	5.1	-	4.4	-	4.0	ns
HIGH to OFF-state propagation delay	$t_{PHZ}$	DIR to A	-	6.0	-	6.0	-	6.0	-	6.0	-	6.0	ns
		DIR to B	-	18.6	-	17.5	-	10.5	-	8.8	-	7.2	ns
LOW to OFF-state propagation delay	$t_{PLZ}$	DIR to A	-	5.8	-	5.8	-	5.8	-	5.8	-	5.8	ns
		DIR to B	-	14.3	-	13.0	-	8.2	-	7.8	-	7.2	ns
OFF-state to HIGH propagation delay	$t_{PZH}$	DIR to A <sup>[1]</sup>	-	25.8	-	20.6	-	13.2	-	12.0	-	9.1	ns
		DIR to B <sup>[1]</sup>	-	22.0	-	20.5	-	12.1	-	10.0	-	8.1	ns
OFF-state to LOW propagation delay	$t_{PZL}$	DIR to A <sup>[1]</sup>	-	30.5	-	25.6	-	15.5	-	12.8	-	10.2	ns
		DIR to B <sup>[1]</sup>	-	22.5	-	19.5	-	12.4	-	10.6	-	9.8	ns

Note: [1]  $t_{PZH}$  and  $t_{PZL}$  are calculated values using the formula shown in Section 6.4.

## 4、Testing Circuit

### 4.1、AC Testing Circuit

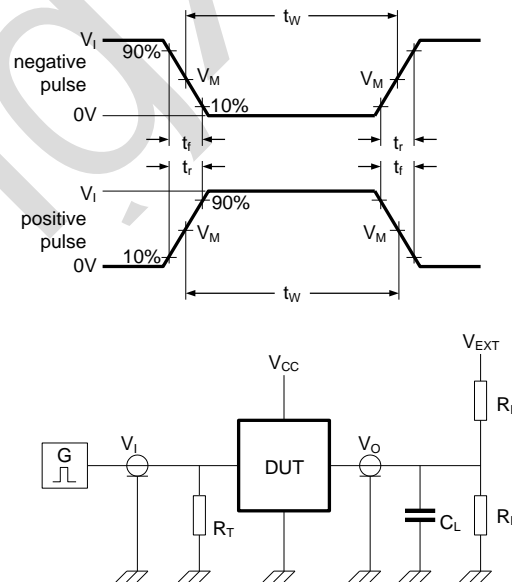

$R_L$ =Load resistance.

$C_L$ =Load capacitance including jig and probe capacitance.

$R_T$ =Termination resistance.

$V_{EXT}$ =External voltage for measuring switching times.

Figure 3. Test circuit for measuring switching times



#### 4.2、Test Data

Supply voltage	Input		Load		$V_{EXT}$		
$V_{CC(A)}, V_{CC(B)}$	$V_I^{[1]}$	$\Delta t/\Delta V^{[2]}$	$C_L$	$R_L$	$t_{PLH}, t_{PHL}$	$t_{PZH}, t_{PHZ}$	$t_{PZL}, t_{PLZ}^{[3]}$
1.2V to 5.5V	$V_{CCI}$	$\leq 1.0\text{ns/V}$	15pF	2k $\Omega$	open	GND	$2V_{CCO}$

Note:

[1]  $V_{CCI}$  is the supply voltage associated with the data input port.

[2]  $dV/dt \geq 1.0\text{V/ns}$ .

[3]  $V_{CCO}$  is the supply voltage associated with the output port.

#### 4.3、AC Testing Waveforms

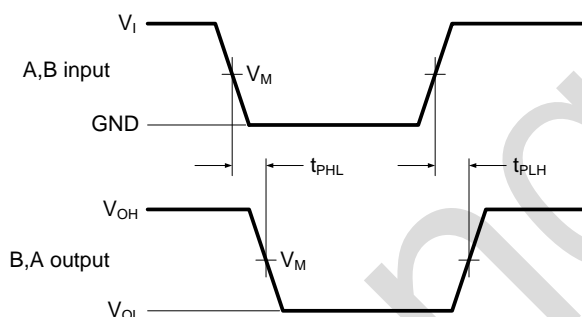

$V_{OL}$  and  $V_{OH}$  are typical output voltage levels that occur with the output load.

Figure 4. The data input (A, B) to output (B, A) propagation delay times

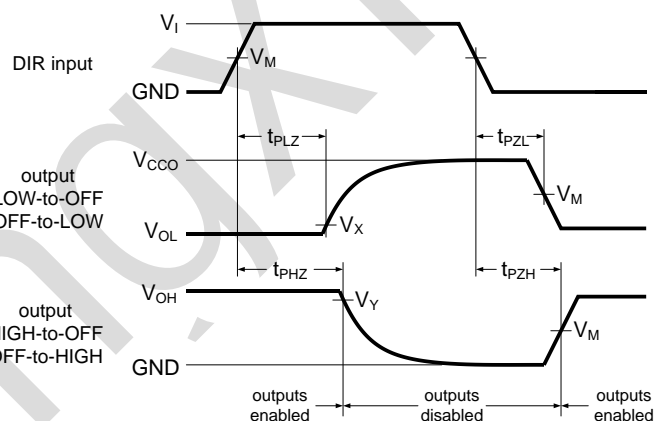

$V_{OL}$  and  $V_{OH}$  are typical output voltage levels that occur with the output load.

Figure 5. Enable and disable times

#### 4.4、Measurement Points

Supply voltage	Input <sup>[1]</sup>	Output <sup>[2]</sup>		
$V_{CC(A)}, V_{CC(B)}$	$V_M$	$V_M$	$V_X$	$V_Y$
1.2V to 1.6V	$0.5V_{CCI}$	$0.5V_{CCO}$	$V_{OL}+0.1\text{V}$	$V_{OH}-0.1\text{V}$
1.65V to 2.7V	$0.5V_{CCI}$	$0.5V_{CCO}$	$V_{OL}+0.15\text{V}$	$V_{OH}-0.15\text{V}$
3.0V to 5.5V	$0.5V_{CCI}$	$0.5V_{CCO}$	$V_{OL}+0.3\text{V}$	$V_{OH}-0.3\text{V}$

Note:

[1]  $V_{CCI}$  is the supply voltage associated with the data input port.

[2]  $V_{CCO}$  is the supply voltage associated with the output port.



## 5、Characteristic Curve

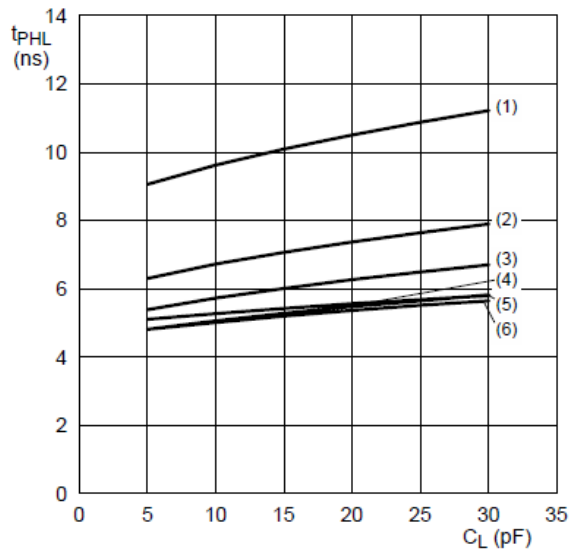

a. HIGH to LOW propagation delay (A to B)

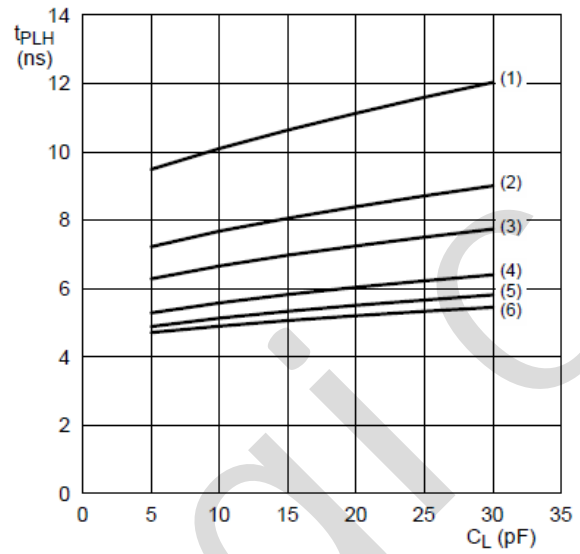

b. LOW to HIGH propagation delay (A to B)

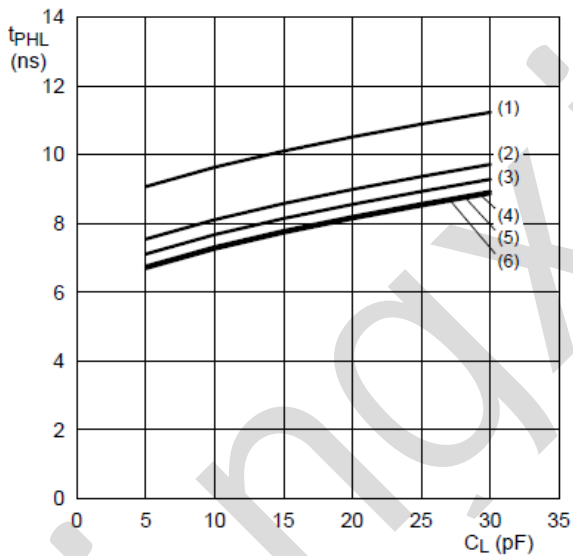

c. HIGH to LOW propagation delay (B to A)

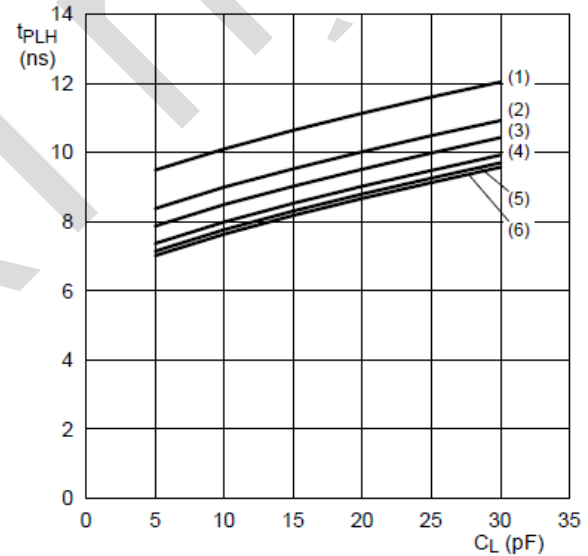

d. LOW to HIGH propagation delay (B to A)

- (1)  $V_{CC(B)}=1.2V$ .
- (2)  $V_{CC(B)}=1.5V$ .
- (3)  $V_{CC(B)}=1.8V$ .
- (4)  $V_{CC(B)}=2.5V$ .
- (5)  $V_{CC(B)}=3.3V$ .
- (6)  $V_{CC(B)}=5.0V$ .

Figure 6. Typical propagation delay versus load capacitance;  $T_{amb}=25^{\circ}C$ ;  $V_{CC(A)}=1.2V$

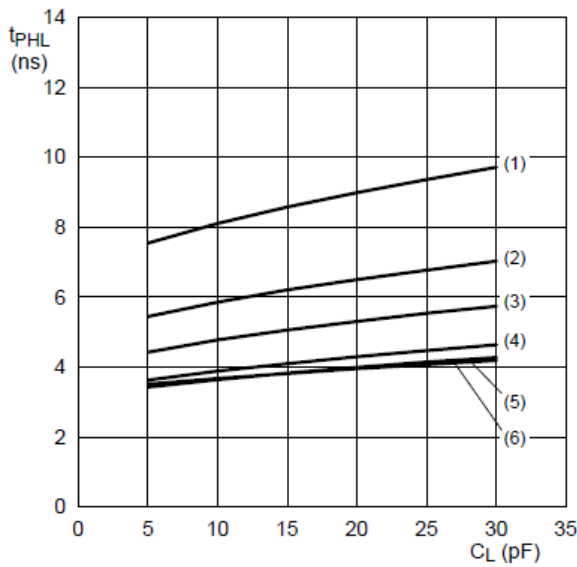

a. HIGH to LOW propagation delay (A to B)

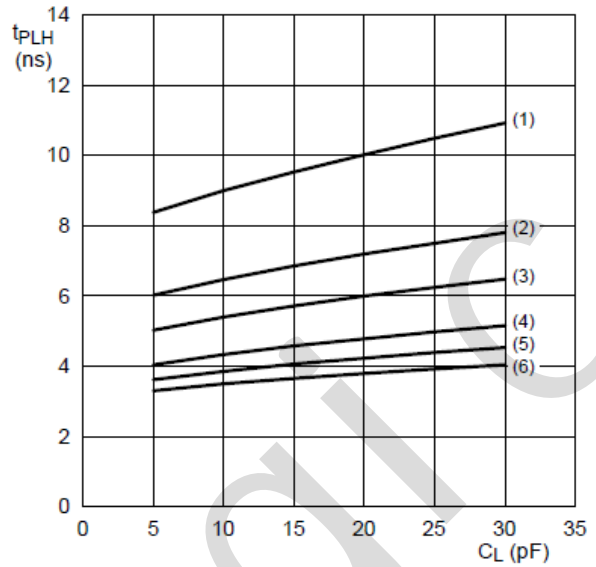

b. LOW to HIGH propagation delay (A to B)

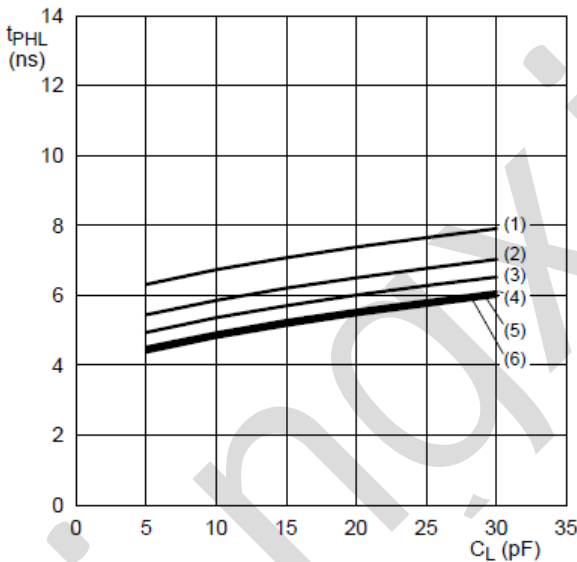

c. HIGH to LOW propagation delay (B to A)

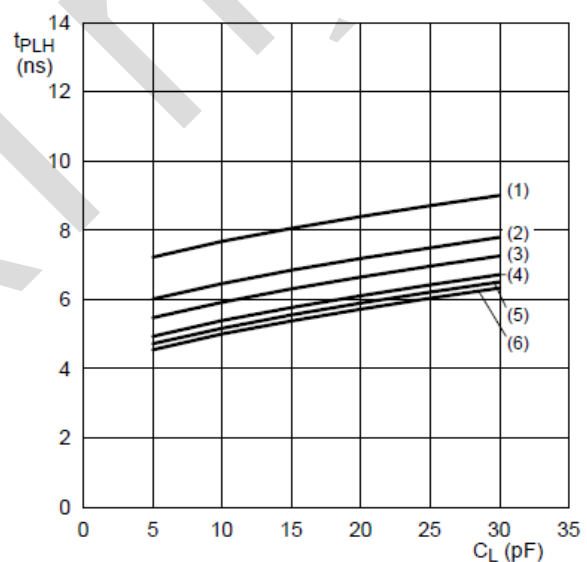

d. LOW to HIGH propagation delay (B to A)

- (1)  $V_{CC(B)}=1.2V$ .
- (2)  $V_{CC(B)}=1.5V$ .
- (3)  $V_{CC(B)}=1.8V$ .
- (4)  $V_{CC(B)}=2.5V$ .
- (5)  $V_{CC(B)}=3.3V$ .
- (6)  $V_{CC(B)}=5.0V$ .

Figure 7. Typical propagation delay versus load capacitance;  $T_{amb}=25^{\circ}C$ ;  $V_{CC(A)}=1.5V$

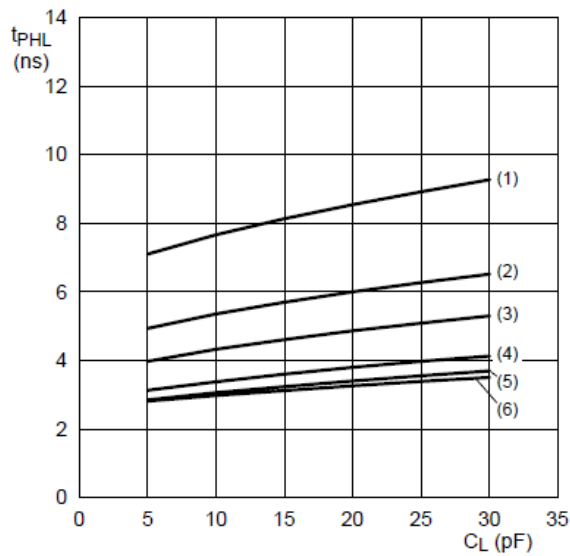

a. HIGH to LOW propagation delay (A to B)

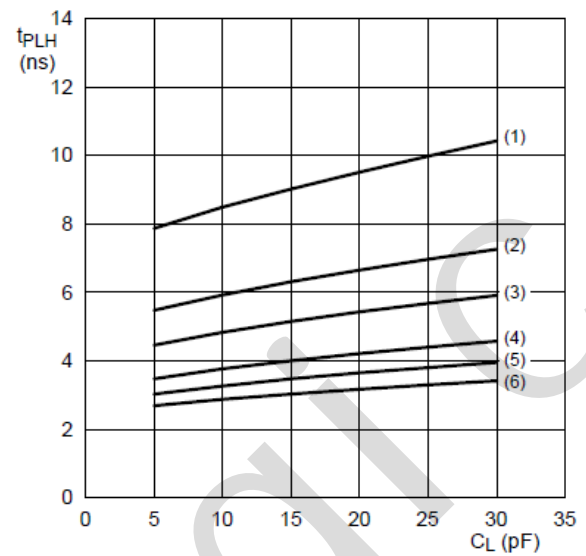

b. LOW to HIGH propagation delay (A to B)

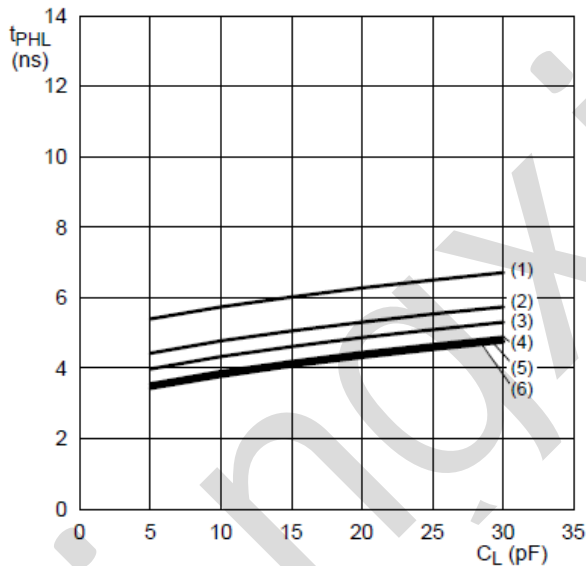

c. HIGH to LOW propagation delay (B to A)

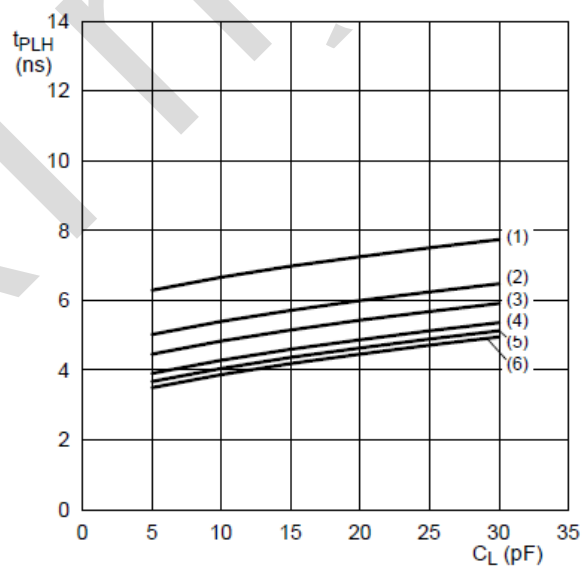

d. LOW to HIGH propagation delay (B to A)

- (1)  $V_{CC(B)}=1.2V$ .
- (2)  $V_{CC(B)}=1.5V$ .
- (3)  $V_{CC(B)}=1.8V$ .
- (4)  $V_{CC(B)}=2.5V$ .
- (5)  $V_{CC(B)}=3.3V$ .
- (6)  $V_{CC(B)}=5.0V$ .

Figure 8. Typical propagation delay versus load capacitance;  $T_{amb}=25^{\circ}C$ ;  $V_{CC(A)}=1.8V$

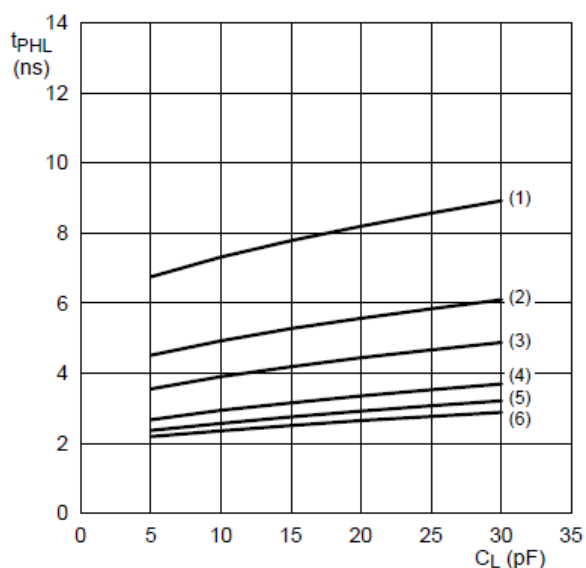

a. HIGH to LOW propagation delay (A to B)

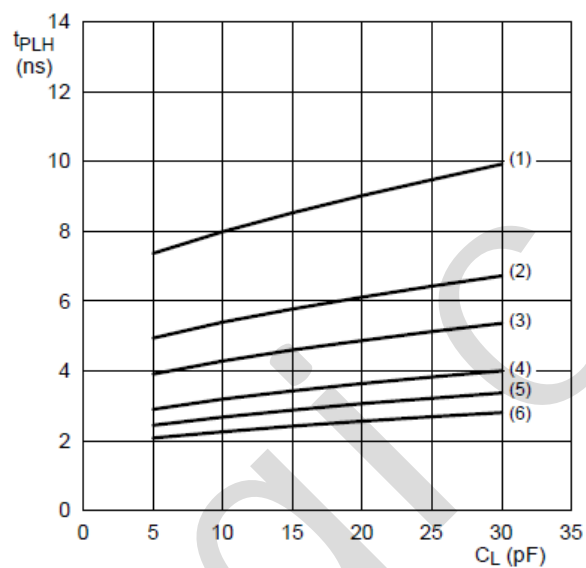

b. LOW to HIGH propagation delay (A to B)

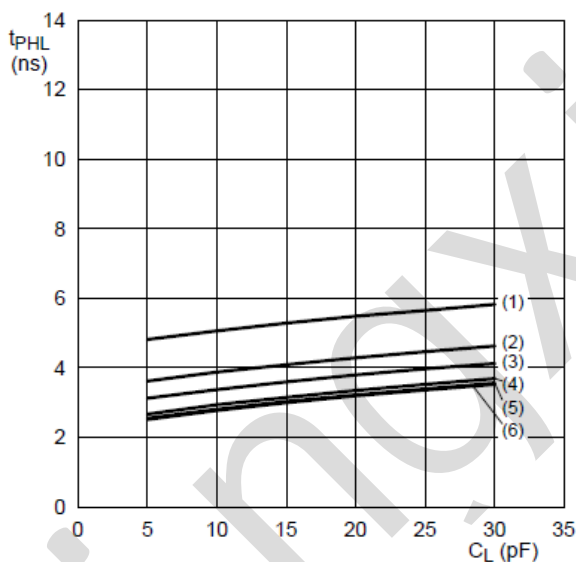

c. HIGH to LOW propagation delay (B to A)

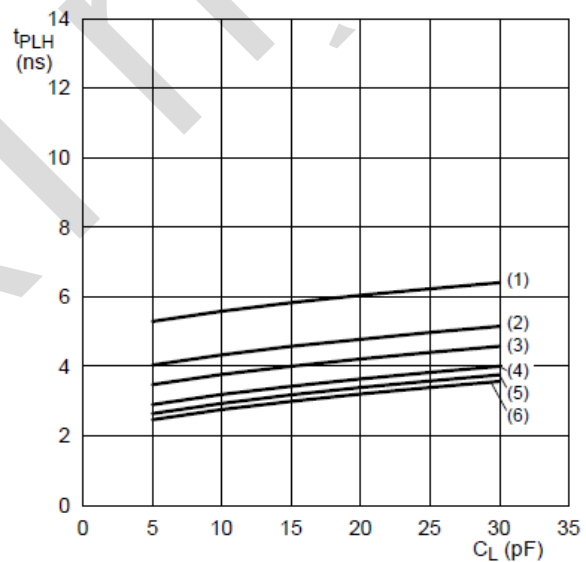

d. LOW to HIGH propagation delay (B to A)

- (1)  $V_{CC(B)}=1.2V$ .
- (2)  $V_{CC(B)}=1.5V$ .
- (3)  $V_{CC(B)}=1.8V$ .
- (4)  $V_{CC(B)}=2.5V$ .
- (5)  $V_{CC(B)}=3.3V$ .
- (6)  $V_{CC(B)}=5.0V$ .

Figure 9. Typical propagation delay versus load capacitance;  $T_{amb}=25^{\circ}C$ ;  $V_{CC(A)}=2.5V$

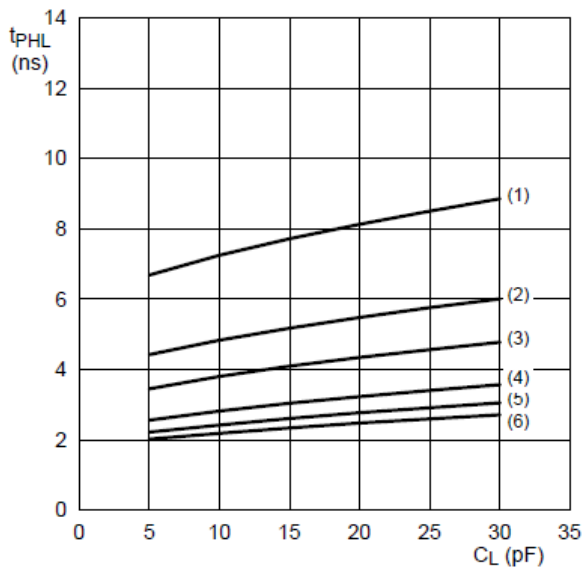

a. HIGH to LOW propagation delay (A to B)

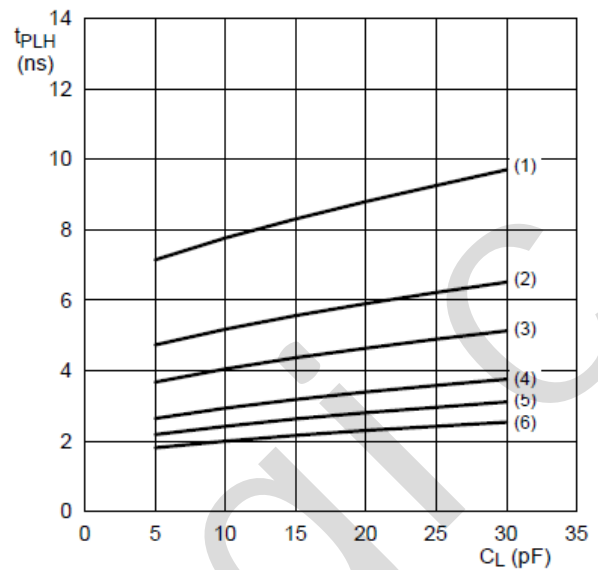

b. LOW to HIGH propagation delay (A to B)

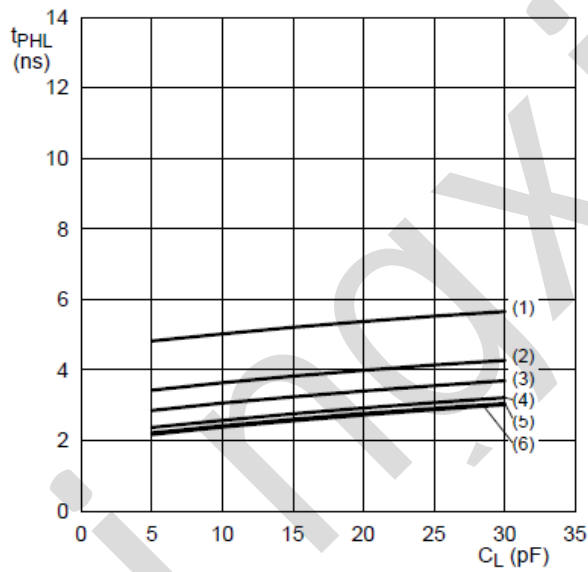

c. HIGH to LOW propagation delay (B to A)

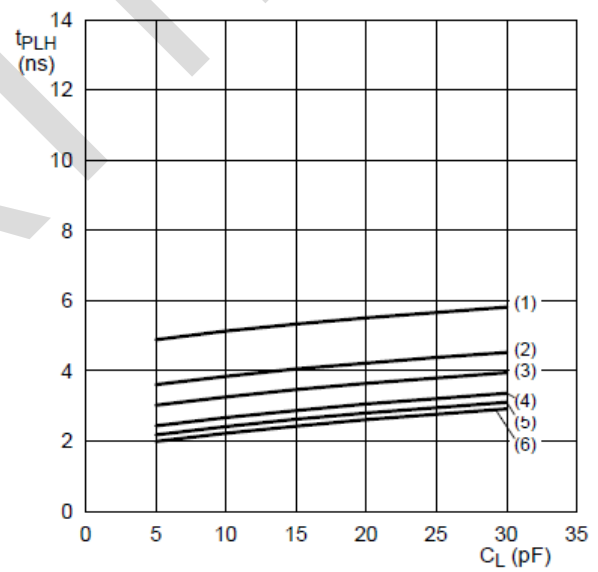

d. LOW to HIGH propagation delay (B to A)

- (1)  $V_{CC(B)}=1.2V$ .
- (2)  $V_{CC(B)}=1.5V$ .
- (3)  $V_{CC(B)}=1.8V$ .
- (4)  $V_{CC(B)}=2.5V$ .
- (5)  $V_{CC(B)}=3.3V$ .
- (6)  $V_{CC(B)}=5.0V$ .

Figure 10. Typical propagation delay versus load capacitance;  $T_{amb}=25^{\circ}C$ ;  $V_{CC(A)}=3.3V$

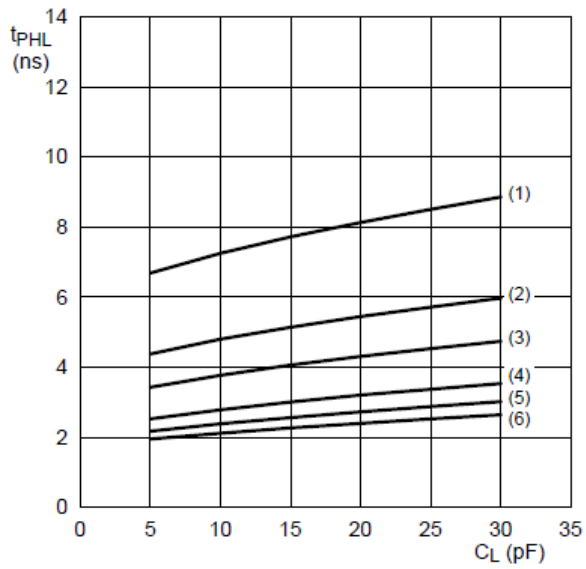

a. HIGH to LOW propagation delay (A to B)

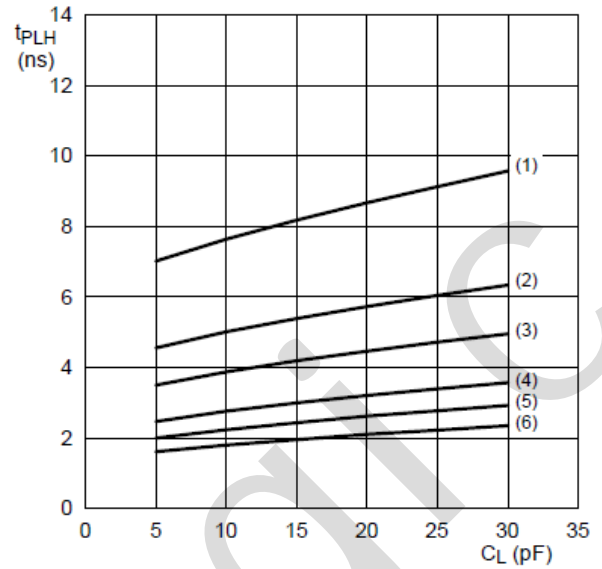

b. LOW to HIGH propagation delay (A to B)

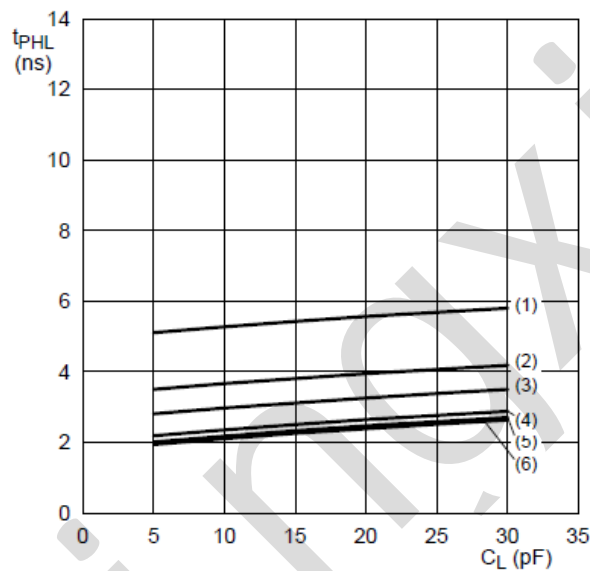

c. HIGH to LOW propagation delay (B to A)

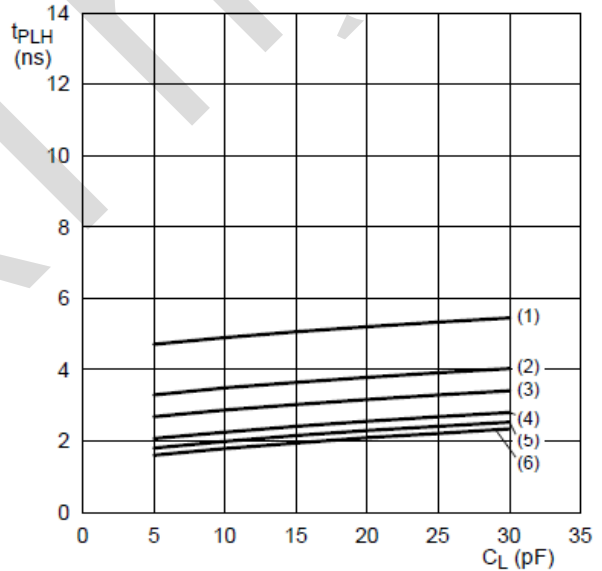

d. LOW to HIGH propagation delay (B to A)

- (1)  $V_{CC(B)}=1.2V$ .
- (2)  $V_{CC(B)}=1.5V$ .
- (3)  $V_{CC(B)}=1.8V$ .
- (4)  $V_{CC(B)}=2.5V$ .
- (5)  $V_{CC(B)}=3.3V$ .
- (6)  $V_{CC(B)}=5.0V$ .

Figure 11. Typical propagation delay versus load capacitance;  $T_{amb}=25^{\circ}C$ ;  $V_{CC(A)}=5.0V$



## 6、Typical Application Circuit And Application Note

### 6.1、Unidirectional Logic Level-shifting Application

The circuit given in Figure 12 is an example of the SN74LVC1T45; SN74LVCH1T45 being used in a unidirectional logic level-shifting application.

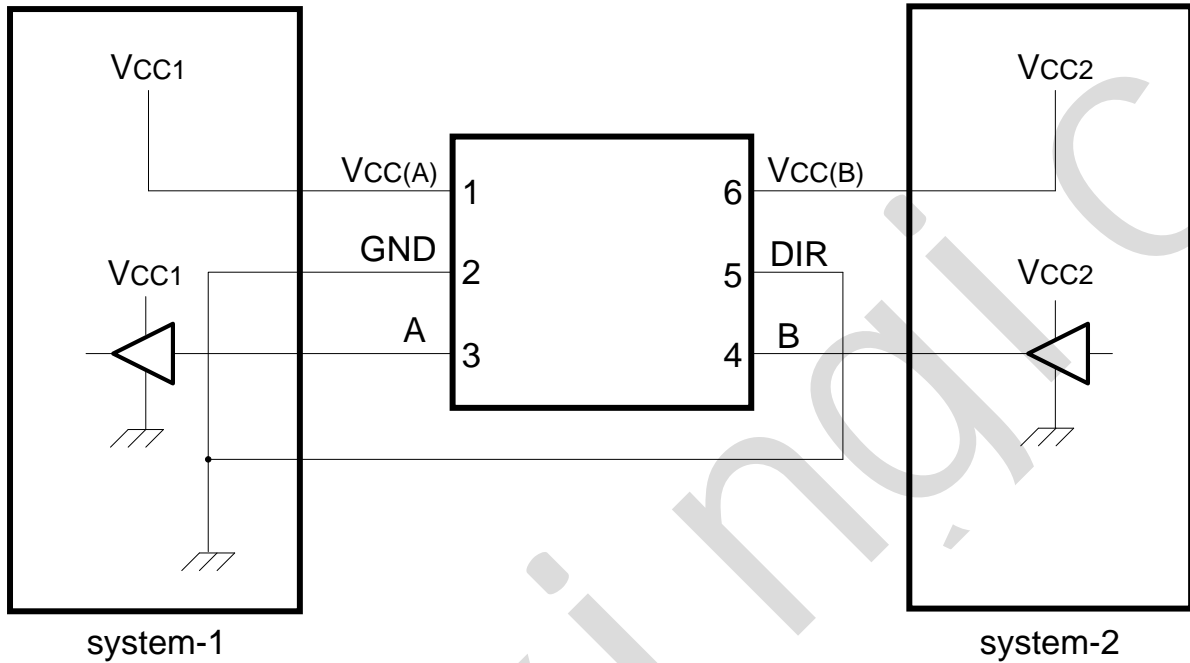

Figure 12. Unidirectional logic level-shifting application

Table 1. Description of unidirectional logic level-shifting application

Pin	Name	Function	Description
1	$V_{CC(A)}$	$V_{CC1}$	supply voltage of system-1 (1.2V to 5.5V)
2	GND	GND	device GND
3	A	OUT	output level depends on $V_{CC1}$ voltage
4	B	IN	input threshold value depends on $V_{CC2}$ voltage
5	DIR	DIR	the GND (LOW level) determines B port to A port direction
6	$V_{CC(B)}$	$V_{CC2}$	supply voltage of system-2 (1.2V to 5.5V)



## 6.2、Bidirectional Logic Level-shifting Application

Figure 13 shows the SN74LVC1T45; SN74LVCH1T45 being used in a bidirectional logic level-shifting application. Since the device does not have an output enable pin, the system designer should take precautions to avoid bus contention between system-1 and system-2 when changing directions.

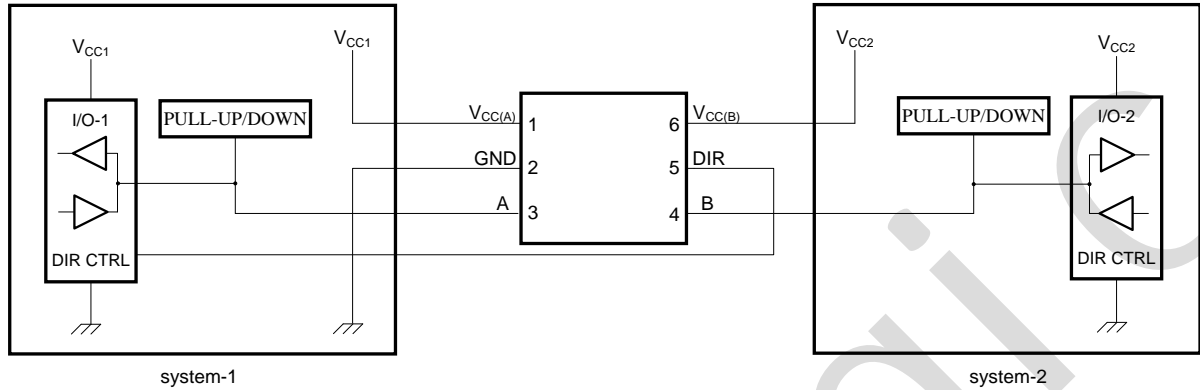

Pull-up or pull-down only needed for SN74LVC1T45.

Figure 13. Bidirectional logic level-shifting application

Table 2 gives a sequence that will illustrate data transmission from system-1 to system-2 and then from system-2 to system-1.

**Table 2. Description of bidirectional logic level-shifting application**

State	DIR CTRL	I/O-1	I/O-2	Description
1	H	output	input	system-1 data to system-2
2	H	Z	Z	system-2 is getting ready to send data to system-1. I/O-1 and I/O-2 are disabled. The bus-line state depends on bus hold.
3	L	Z	Z	DIR bit is set LOW. I/O-1 and I/O-2 still are disabled. The bus-line state depends on bus hold.
4	L	input	output	system-2 data to system-1

Note:

H=HIGH voltage level;

L=LOW voltage level;

Z=high-impedance OFF-state.



### 6.3. Power-up Considerations

The device is designed such that no special power-up sequence is required other than GND being applied first.

**Table 3. Typical total supply current ( $I_{CC(A)}+I_{CC(B)}$ )**

$V_{CC(A)}$	$V_{CC(B)}$					Unit
	0V	0.8V	2.5V	3.3V	5.0V	
0V	0	<1	<1	<1	<1	uA
1.8V	<1	<2	<2	<2	2	uA
2.5V	<1	<2	<2	<2	<2	uA
3.3V	<1	<2	<2	<2	<2	uA
5.0V	<1	2	<2	<2	<2	uA

### 6.4. Enable Times

Calculate the enable times for the SN74LVC1T45; SN74LVCH1T45 using the following formulas:

- $t_{PZH}(\text{DIR to A})=t_{PLZ}(\text{DIR to B})+t_{PLH}(\text{B to A})$
- $t_{PZL}(\text{DIR to A})=t_{PHZ}(\text{DIR to B})+t_{PHL}(\text{B to A})$
- $t_{PZH}(\text{DIR to B})=t_{PLZ}(\text{DIR to A})+t_{PLH}(\text{A to B})$
- $t_{PZL}(\text{DIR to B})=t_{PHZ}(\text{DIR to A})+t_{PHL}(\text{A to B})$

In a bidirectional application, these enable times provide the maximum delay from the time the DIR bit is switched until an output is expected. For example, if the SN74LVC1T45; SN74LVCH1T45 initially is transmitting from A to B, then the DIR bit is switched, the B port of the device must be disabled before presenting it with an input. After the B port has been disabled, an input signal applied to it appears on the corresponding A port after the specified propagation delay.



## 7、Package Information

### 7.1、SOT-23-6

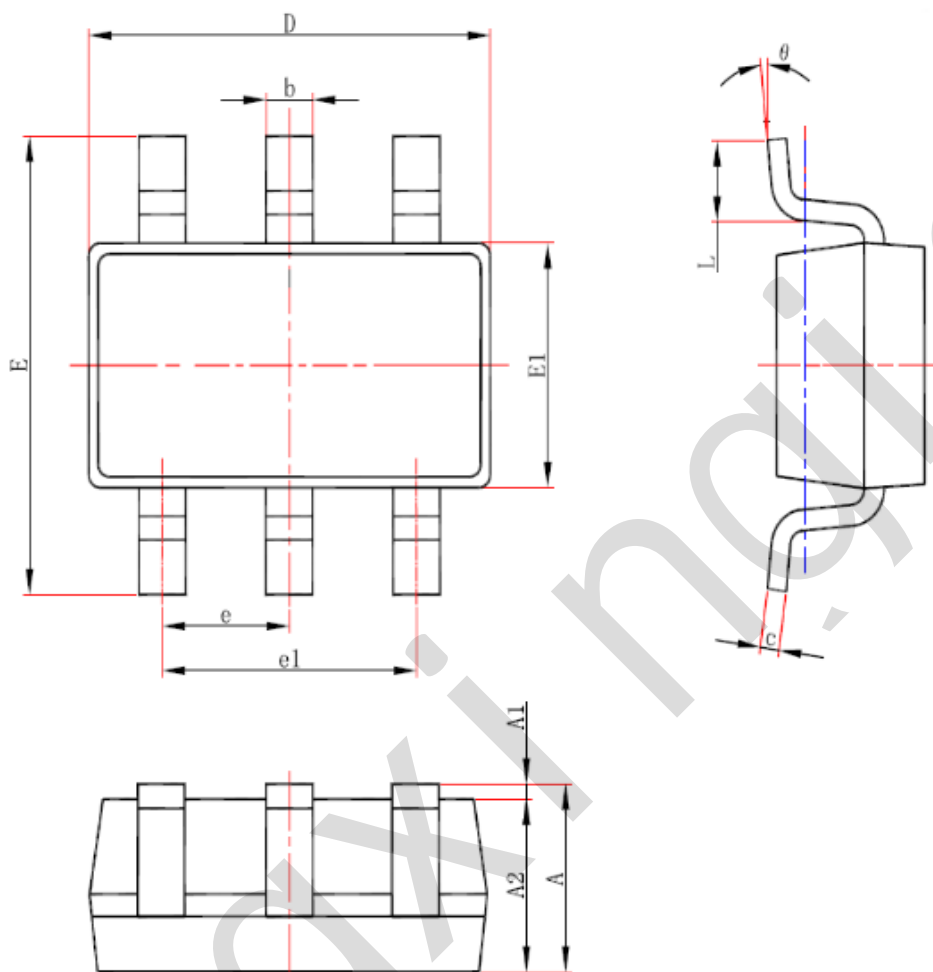

Symbol	Dimensions (mm)	
	Min.	Max.
A	-	1.25
A1	0.00	0.12
A2	1.00	1.20
b	0.30	0.50
c	0.10	0.20
D	2.82	3.02
E	2.60	3.00
E1	1.50	1.70
e	0.95	
e1	1.80	2.00
L	0.30	0.60
θ	0°	8°



7.2、SOT-363

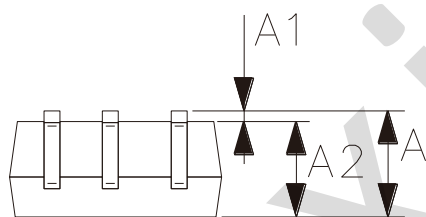
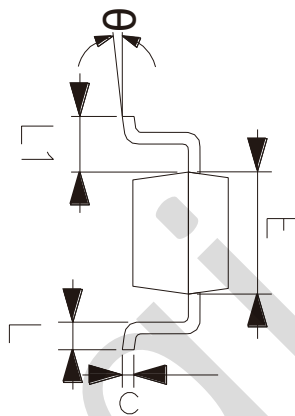
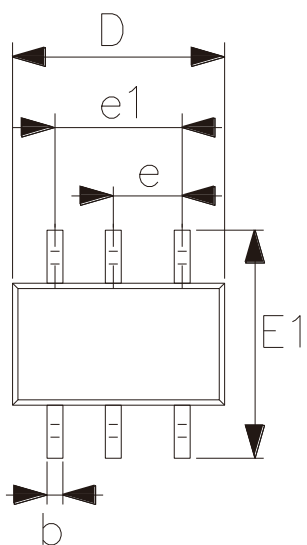

Symbol	Dimensions (mm)	
	Min.	Max.
A	0.90	1.10
A1	0.00	0.10
A2	0.90	1.00
b	0.15	0.35
c	0.11	0.175
D	2.00	2.20
E1	2.15	2.45
E	1.15	1.35
e	0.65	
e1	1.20	1.40
L	0.26	0.46
L1	0.525	
$\theta$	0°	8°



## 8、 Statements

### 8.1、 The name and content of Hazardous substances or Elements in the product

Part name	Hazardous substances or Elements									
	Lead and lead compounds	Mercury and mercury compounds	Cadmium and cadmium compounds	Hexavalent chromium compounds	Polybrominated biphenyls	Polybrominated biphenyl ethers	Dibutyl phthalate	Butylbenzyl phthalate	Di-2-ethylhexyl phthalate	Diisobutyl phthalate
Lead frame	○	○	○	○	○	○	○	○	○	○
Plastic resin	○	○	○	○	○	○	○	○	○	○
Chip	○	○	○	○	○	○	○	○	○	○
The lead	○	○	○	○	○	○	○	○	○	○
Plastic sheet installed	○	○	○	○	○	○	○	○	○	○
explanation	<p>○: Indicates that the content of hazardous substances or elements in the detection limit of the following the SJ/T11363-2006 standard.</p> <p>×: Indicates that the content of hazardous substances or elements exceeding the SJ/T11363-2006 Standard limit requirements.</p>									

## X-ON Electronics

Largest Supplier of Electrical and Electronic Components

*Click to view similar products for [Translation - Voltage Levels](#) category:*

*Click to view products by [lingxingic](#) manufacturer:*

Other Similar products are found below :

[NLSX4373DMR2G](#) [NLSX5012MUTAG](#) [NLSX0102FCT1G](#) [PCA9306FMUTAG](#) [MC100EPT622MNG](#) [NLSX3014MUTAG](#)  
[NLSX5011MUTCG](#) [NLV5X4373MUTAG](#) [NB3U23CMNTAG](#) [NLSX3013BFCT1G](#) [NLV7WBD3125USG](#) [NLSX3012DMR2G](#)  
[NLA9306MU3TCG](#) [PI4ULS3V304AZMAEX](#) [PI4ULS3V504AZMAEX](#) [74AVCH1T45FW3-7](#) [NLSX5011AMUTAG](#) [74AXP1T34GWH](#)  
[ST2149BQTR](#) [MC100ELT21DR2G](#) [MC100LVELT22MNRG](#) [MC10ELT20DR2G](#) [MC10EPT20MNR4G](#) [MC14504BFELG](#)  
[NLSV4T3234FCT1G](#) [NLSX3378BFCT1G](#) [UM3208QA](#) [UM3208H](#) [UM3304](#) [UM3304QT](#) [UM3202H](#) [UM3308](#) [RS0104YTQE12](#)  
[RS0204YUTQH12](#) [AW39204QNR](#) [AW39114FOR](#) [RS0104YTQF14](#) [RS0204YTQF14](#) [UM3204QT](#) [UM3204QB](#) [UM3204QV](#)  
[AIPTB0106TA16.TR](#) [AIPTS0104TA14.TR](#) [AIPTB0104TA14.TR](#) [UM3304QS](#) [SN74LXC2T45DCUR](#) [TXU0202DCUR](#) [TCA39306DTMR](#)  
[NTS0102TL-Q100H](#) [AW39112DNR](#)