



## ARR-NF-NF-B

### N Jack to N Jack Sealed Bulkhead Lightning Arrester

The ARR-NF-NF-B is an N jack (female socket) to N jack IP67-rated sealed bulkhead lightning arrester, which includes a silicone gasket, washer, and hex nut for installation as well as an optional aluminum mounting bracket. Operating from 0 Hz to 6 GHz, the ARR-NF-NF-B provides superior performance in a gas discharge DC pass-through type lightning arrester. Additionally, all Linx lightning arresters are tested to meet requirements for corrosion resistance, vibration, mechanical and thermal shock.

#### FEATURES

- 0 Hz to 6 GHz operation
- Gas discharge DC pass-through type lightning arrester
- N jack (female socket) connection
  - Gold plated brass center contact
- Brass hex nut, washer, silicone gasket and optional mounting bracket provided
- IP67 rated

#### APPLICATIONS

- Outdoor Networks
- Low-power, wide-area (LPWA)
  - Helium™, LoRaWan®, Sigfox®, Wifi HaLow™
- Private Cellular Networks
  - Citizens Broadband Radio Service (CBRS)
- Public Safety
- Internet of Things (IoT)
- C-V2I (Cellular Vehicle to Infrastructure)
- Cellular IoT
  - LTE-M (Cat-M1), NB-IoT
- Cellular
  - 5G/4G LTE/3G/2G
- WiFi 6/5/4, 802.11b/g

#### ORDERING INFORMATION

Part Number	Description
ARR-NF-NF-B	WiFi 6/WiFi 6E blade-style antenna with SMA plug (male pin)

Available from Linx Technologies and select distributors and representatives.

## PERFORMANCE

Table 1 shows the electrical specifications, insertion loss and VSWR values for the ARR-NF-NF-B lightning arrester at commonly used frequencies.

Insertion loss is the loss of signal power (gain) resulting from the insertion of a device in a transmission line. VSWR describes how efficiently power is transmitted through the lightning arrester. A lower VSWR value indicates better performance at a given frequency.

**TABLE 1. ELECTRICAL SPECIFICATIONS**

Band	Low-Band Cellular/ ISM/LPWA	Midband Cellular/ GNSS	ISM	WiFi 6/5/4
Frequency Range	400 MHz to 960 MHz	1.1 GHz to 5 GHz	2.4 GHz	2.4 GHz to 6 GHz
Insertion Loss (dB max)	0.08	0.27	0.11	0.20
VSWR (max)	1.0	1.3	1.0	1.3
Impedance	50 Ω			
Frequency Range	0 Hz to 6 GHz			
Voltage Rating	230 V RMS			
Input Power	90W/CW @ 30 MHz 9W/CW @ 3 GHz			
Surge Current	10 kA (wave 8/20 μs)			
Turn-on Voltage	230 V ±20%			
Insulation Resistance	≥ 1 GΩ @100 VDC			
Gas Discharge Tube Lifespan	5 years, in service*			

\*All gas discharge tube type arresters require replacement after 5 years of service to ensure proper function and protection of electronics.

**TABLE 2. MECHANICAL SPECIFICATIONS**

ARR-NF-NF-B	
Mounting Type	Sealed Bulkhead Mount
Fastening Type	5/8"-24UNEF Threaded Coupling
Interface	MIL-STD-348A
Recommended Torque	0.85 N m (7.5 ft lbs)
Coupling Nut Retention	100 lbs. min.
Connector Durability	500 cycles min.
Weight	101.4 g (3.60 oz)

**TABLE 3. ENVIRONMENTAL SPECIFICATIONS**

MIL-STD/Method/Test Condition	
Corrosion (Salt spray)	MIL-STD-202 Method 101 test condition B
Thermal Shock	MIL-STD-202 Method 107 test condition B
Vibration	MIL-STD-202 Method 204 test condition B
Mechanical Shock	MIL-STD-202 Method 213 test condition I
Temperature Range	-55 °C to +105 °C
Environmental Compliance	RoHS, REACH

## PRODUCT DIMENSIONS

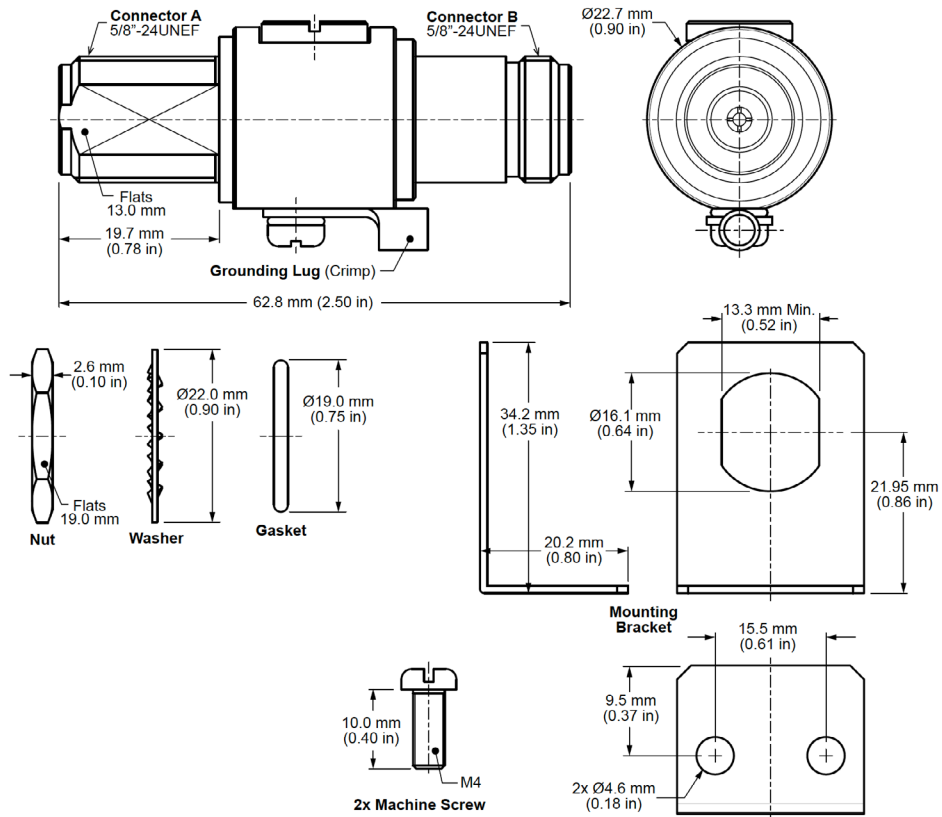

Figure 1. Product Dimensions for the ARR-NF-NF-B Lightning Arrester

## TABLE 4. LIGHTNING ARRESTER COMPONENTS

ARR-NF-NF-B	Connector A N jack (female socket) Sealed Bulkhead		Connector B N jack (female socket)	
	Material	Finish	Material	Finish
Body	Brass	Nickel	Brass	Nickel
Center Contact (socket)	Brass	Gold	Brass	Gold
Insulator	PTFE	-	PTFE	-
Gasket	Silicone	-	-	-
Washer	Brass	Nickel	-	-
Hex Nut	Brass	Nickel	-	-
Mounting Bracket	Aluminum	-	-	-
Machine Screws (2x)	Iron	Nickel	-	-

## INSTALLATION

The ARR-NF-NF-B lightning arrester must be coupled to an appropriate ground using the provided crimp type ground terminal and AWG 18, or larger, stranded grounding wire. Failure to properly ground the lightning arrester will impede the ability of the arrester to protect electronic equipment. The ARR-NF-NF-B lightning arrester connects inline and can remain free-hanging or mounted through a bulkhead using the provided gasket, washer and nut. The maximum bulkhead thickness = 6.2 mm (0.24 in) and the nut should be tightened to a torque setting of 5 in/lbs max. Mounting is also possible using the provided mounting bracket and two M4 x 10 machine screws. The recommended enclosure mounting dimensions for the ARR-NF-NF-B are shown in Figure 2.

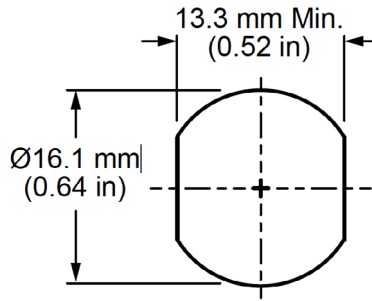

Figure 2. Recommended Enclosure Mounting Dimensions

## PACKAGING INFORMATION

The ARR-NF-NF-B lightning arrester is packaged in a plastic bag and placed in an individual carton with the mounting hardware which is sealed in a separate plastic bag. Distribution channels may offer alternative packaging options.

## CONNECTOR & ADAPTER DEFINITIONS AND USEFUL FORMULAS

VSWR - Voltage Standing Wave Ratio. VSWR is a unitless ratio that describes how efficiently power is transmitted through the connector. A lower VSWR value indicates better performance at a given frequency. VSWR is easily derived from Return Loss.

$$VSWR = \frac{10^{\left[\frac{\text{Return Loss}}{20}\right]} + 1}{10^{\left[\frac{\text{Return Loss}}{20}\right]} - 1}$$

Insertion Loss - The loss of signal power (gain) resulting from the insertion of a device in a transmission line. Insertion loss can be derived from the power transmitted to the load before the insertion of the component  $P_T$  and the power transmitted to the load after the insertion of the component  $P_R$ .

$$\text{Insertion Loss (dB)} = 10 \log_{10} \frac{P_T}{P_R}$$

---

## TE TECHNICAL SUPPORT CENTER

USA:	+1 (800) 522-6752
Canada:	+1 (905) 475-6222
Mexico:	+52 (0) 55-1106-0800
Latin/S. America:	+54 (0) 11-4733-2200
Germany:	+49 (0) 6251-133-1999
UK:	+44 (0) 800-267666
France:	+33 (0) 1-3420-8686
Netherlands:	+31 (0) 73-6246-999
China:	+86 (0) 400-820-6015

## te.com

TE Connectivity, TE, TE connectivity (logo), Linx and Linx Technologies are trademarks owned or licensed by the TE Connectivity Ltd. family of companies. All other logos, products and/or company names referred to herein might be trademarks of their respective owners.

The information given herein, including drawings, illustrations and schematics which are intended for illustration purposes only, is believed to be reliable. However, TE Connectivity makes no warranties as to its accuracy or completeness and disclaims any liability in connection with its use. TE Connectivity's obligations shall only be as set forth in TE Connectivity's Standard Terms and Conditions of Sale for this product and in no case will TE Connectivity be liable for any incidental, indirect or consequential damages arising out of the sale, resale, use or misuse of the product. Users of TE Connectivity products should make their own evaluation to determine the suitability of each such product for the specific application.

TE Connectivity warrants to the original end user customer of its products that its products are free from defects in material and workmanship. Subject to conditions and limitations TE Connectivity will, at its option, either repair or replace any part of its products that prove defective because of improper workmanship or materials. This limited warranty is in force for the useful lifetime of the original end product into which the TE Connectivity product is installed. Useful lifetime of the original end product may vary but is not warranted to exceed one (1) year from the original date of the end product purchase.

©2022 TE Connectivity. All Rights Reserved.

09/22 Original

## X-ON Electronics

Largest Supplier of Electrical and Electronic Components

*Click to view similar products for* [RF Adapters - Between Series category:](#)

*Click to view products by* [Linx Technologies manufacturer:](#)

Other Similar products are found below :

[5945-9503-000](#) [ADBJ20-E1-BJ379](#) [242191](#) [9317505](#) [AD130](#) [ADBJ77-A1PL3155](#) [242190](#) [25-7580TP](#) [HRM.J-ML51.J-A](#) [UAD95](#) [8311505](#)  
[R114704000](#) [R192421000](#) [242201RP](#) [03K719-S22S3](#) [AD-RSMAF-RTNC](#) [02K119-S00E3](#) [02K119-K00E3](#) [28K132-K00N5](#) [29-3840P](#) [ADP-](#)  
[SMAF-MM CXM](#) [TM-FMEM-NDS-50](#) [AD-MQF-QCM-PM-2.5](#) [AD-QCF-QCF-SP-2.5](#) [AD-HQM-QCM-PM-2.5](#) [AD-MQM-QCM-PM-2.5](#)  
[AD-HQF-QCM-PM-2.5](#) [PRFBA-100-J-185-J-S](#) [000-2900](#) [R191630007](#) [1057367-1](#) [1057377-1](#) [321-201-002 \(SMA-50-R/2-H155/W1.02 AU\)](#)  
[321-203-001 \(SMA-50-R/2-RG58/W3.01\)](#) [321-203-002 \(SMA-50-R/2-RG58/W3.02\)](#) [321-350-001 \(SMA-50-R/2-RG316/N2.01\)](#) [RF2-03-T-00-](#)  
[50-G](#) [4295](#) [1269#](#) [1270](#) [BNC\(75\)J-H.FLJ-BPA-V\(40\)](#) [1296](#) [1297](#) [321-102-002 \(SMA-50/2-H155/W1.02\)](#) [321-103-002 \(SMA-50/2-](#)  
[RG58/W3.02\)](#) [321-351-001 \(SMA-50-R/2-H155/N1.01\)](#) [400PSM-CR](#) [1468](#) [02K118-K00S3](#) [53K164-S00N1](#)