

REVISIONS			
REV	DESCRIPTION	DATE	APPV
A	INITIAL RELEASE OF INTERNAL DOCUMENT	2-FEB-12	SAH
B	UPDATED DIMENSIONS; ADDED THROUGH HOLE PIN LENGTH DIMENSION	10-AUG-16	SAH
C	ADDED PART NUMBER TABLE AND SECOND SHEET; UPDATED NOTE 3	23-JUL-18	CLL

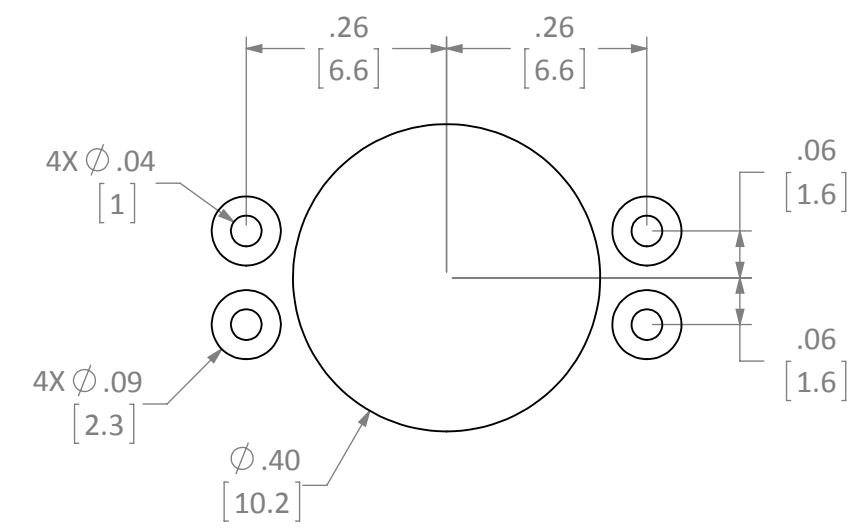

RECOMMENDED FOOTPRINT

- NOTES: (UNLESS OTHERWISE SPECIFIED)
1. ALL DIMENSIONS ARE IN INCHES [mm].
  2. DIMENSIONS APPLY AFTER FINISHING.
  3. MANUFACTURE TO BE COMPLIANT WITH EU RoHS DIRECTIVE.
  4. SAFETY BREAK ALL SHARP CORNERS AND EDGES .02 MAXIMUM, USE MATERIALS THAT DO NOT CONTAIN REACH SUBSTANCES OF VERY HIGH CONCERN >1000ppm, AND USE DRC CONFLICT-FREE SOURCED MATERIALS.

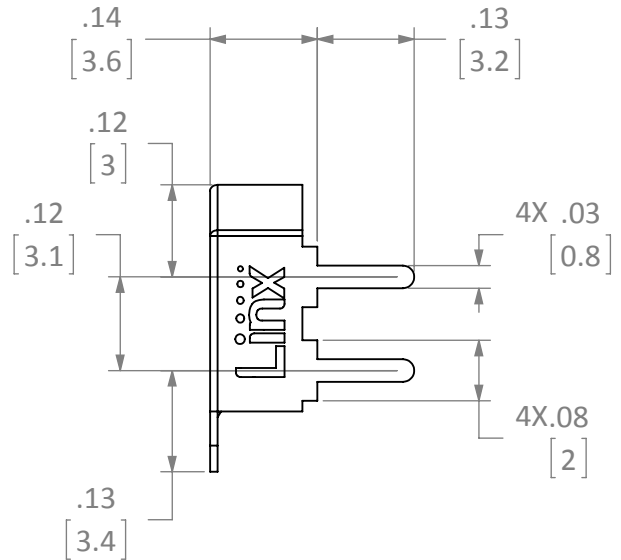
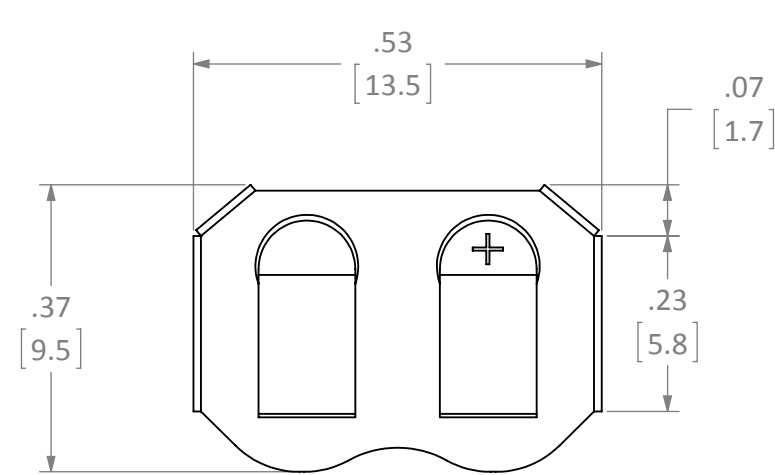
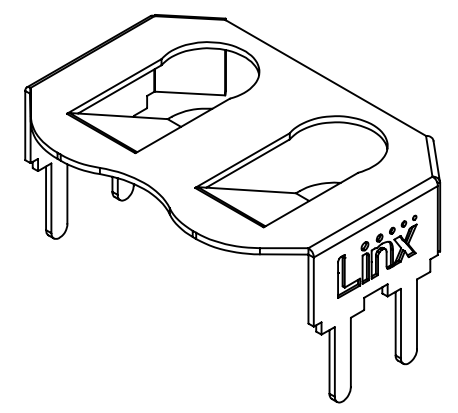

PART NUMBER	PACKAGING
BAT-HLD-012-THM	BULK
BAT-HLD-012-THM-TR	TAPE & REEL

<b>WARNING:</b> THIS DRAWING CONTAINS PROPRIETARY INFORMATION THAT IS THE SOLE PROPERTY OF LINX TECHNOLOGIES, AND SHALL BE TREATED AS SUCH. NO DISCLOSURE OR REPRODUCTION OF THIS DOCUMENT IS PERMITTED, IN WHOLE OR IN PART, WITHOUT THE EXPRESS WRITTEN PERMISSION OF LINX TECHNOLOGIES OR ITS DESIGNATED AGENTS.		159 ORT LANE MERLIN, OR 97532	
MATERIAL: PHOSPHOR BRONZE #C-5191	INTERPRET DIMENSIONS AND TOLERANCES PER ASME Y14.5. SURFACE FINISH: $\sqrt{32}$ ANGLES: $\pm 1^\circ$ TOLERANCES: .X $\pm$ .1 .XX $\pm$ .01 .XXX $\pm$ .005	PROJECTION: 	TITLE: <b>CR1216,1225 HOLDER OUTLINE THROUGH HOLE MOUNT</b>
FINISH: NICKEL PLATE	DRAWN: B.MURPHY ENGR: S.HOGAN	DT: 2-FEB-12 DT: 2-FEB-12	SIZE DWG. NO. REV <b>B</b> BAT-HLD-012-THM-OTL <b>C</b>
		SCALE: 4:1	DO NOT SCALE DRAWING SHEET 1 OF 2

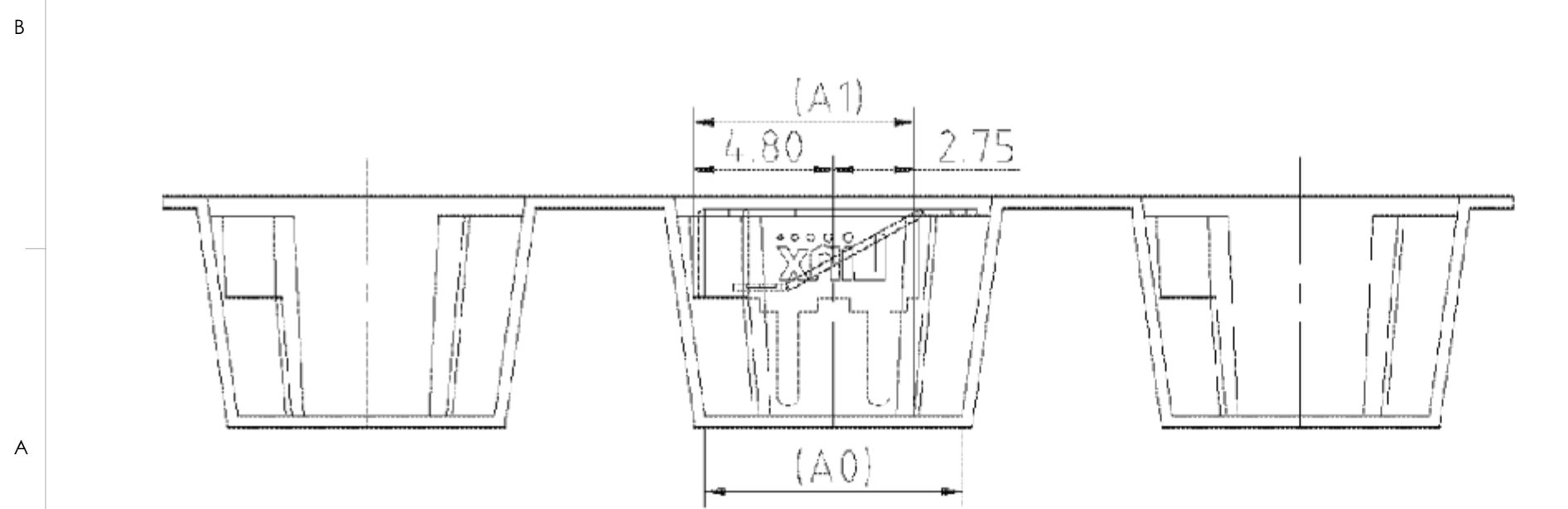
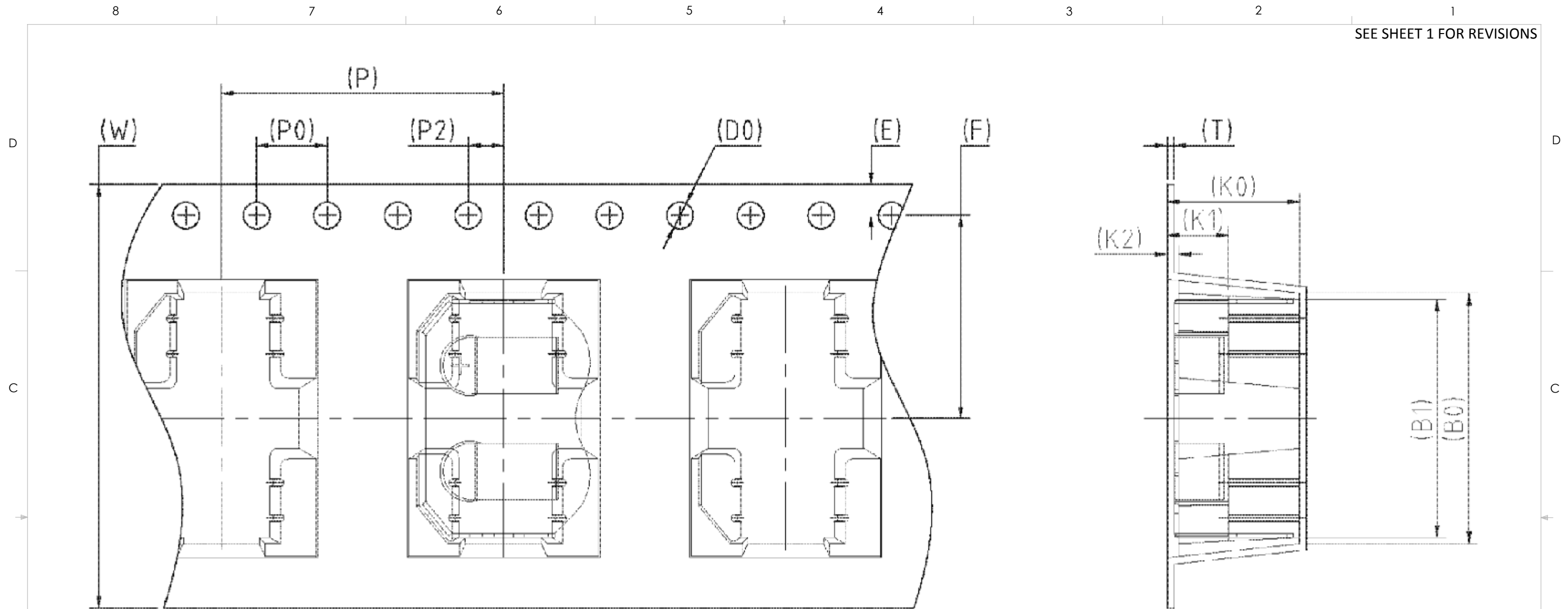

- NOTES: (UNLESS OTHERWISE SPECIFIED)
1. ALL DIMENSIONS ARE IN MILLIMETERS [INCHES].
  2. 10 SPROCKET HOLE PITCH CUMULATIVE TOLERANCE  $\pm 0.2\text{mm}$ .
  3. MATERIAL: BLACK POLYSTYRENE.
  4. PACKING LENGTH PER 22" REEL: 29.4 m.
  5. COMPONENT LOAD PER 13" REEL: 550.
  6. ANGLE TOLERANCE:  $\pm 1^\circ$
  7. CARRIER CAMBER IS WITHIN 1 mm IN 250 mm.

W	24.00 $\pm 0.30$	P	16.00 $\pm 0.10$	A0	8.80 $\pm 0.10$	B0	14.20 $\pm 0.10$
S		P0	4.00 $\pm 0.10$	A1	7.55 <sup>+0.15</sup> <sub>-0.05</sub>	B1	13.50 $\pm 0.10$
E	1.75 $\pm 0.10$	P2	2.00 $\pm 0.10$	A2		B2	
F	11.50 $\pm 0.10$	D0	$\phi 1.50$ <sup>+0.10</sup> <sub>-0.00</sub>	K0	7.50 $\pm 0.10$	K2	0.65 $\pm 0.10$
T	0.40 $\pm 0.05$	D1		K1	3.45 $\pm 0.10$	COLOR: BK/ANT	

SIZE	DWG. NO.	REV
<b>B</b>	BAT-HLD-012-THM-TR	<b>C</b>
SCALE: 4:1	DO NOT SCALE DRAWING	SHEET 2 OF 2

## X-ON Electronics

Largest Supplier of Electrical and Electronic Components

*Click to view similar products for [Coin Cell Battery Holders](#) category:*

*Click to view products by [Linx Technologies](#) manufacturer:*

Other Similar products are found below :

[SMTU2450N-LF](#) [PDSN-11-D](#) [1058](#) [1052](#) [799-2007](#) [BH44AAB](#) [BH48DL](#) [BH8000](#) [BS-6-1](#) [79573231](#) [101](#) [3035](#) [1025](#) [1026](#) [1027](#) [103](#)  
[1059](#) [1060](#) [1063](#) [1065](#) [D3](#) [46400000](#) [BC-0403](#) [BH-121-1B](#) [BH-1/2AA-2A](#) [BH-131A](#) [BH-3101A](#) [BH-3103B](#) [BH-311-1A](#) [BH-311-1D](#) [BH-](#)  
[321-1A](#) [BH-321-1B](#) [BH-321-1D](#) [BH-331-3D](#) [BH-331P](#) [BH-333A](#) [BH-341-1P](#) [BH-351A](#) [BH-362B](#) [BH-421A](#) [BH-422A](#) [BH-425A](#) [BH-](#)  
[431-1B](#) [BH-463A](#) [BH-511A](#) [BHC-18650-1P](#) [46300000](#) [46600000](#) [799-2001](#) [SBH-331A](#)