



## CSE-SBRM-ccc-SBRM

### SMB Plug to SMB Plug Cable Assembly

The CSE-SBRM-ccc-SBRM cable assembly provides a right angle SMB plug (female socket) to right angle SMB plug (female socket) connection with the option of 6 in., 12 in., or 24 in. lengths of RG-316/U coaxial cable.

Operating from 0 GHz to 4 GHz, the CSE-SBRM-ccc-SBRM cable assembly combines superior performance, compact size, and a convenient snap-on mating interface to provide a reliable, easy-to-use connector. Additionally, all Linx coaxial cables and connectors meet RoHS lead free standards and are tested to meet requirements for corrosion resistance, vibration, mechanical and thermal shock.

### FEATURES

- 0 to 4 GHz operation
- RG-316/U 50  $\Omega$  coaxial cable
- SMB plug (female socket)
  - Snap-on mating
  - Gold plating
  - Superior corrosion resistance
  - Right angle connection

### APPLICATIONS

- LPWA
  - LoRaWAN<sup>®</sup>, Sigfox<sup>®</sup> WiFi HaLow<sup>™</sup> (802.11ah)
- Cellular IoT - LTE-M (Cat-M1), NB-IoT
- Cellular - 5G/4G LTE/3G/2G
- PC, LAN
- ISM - Bluetooth<sup>®</sup>, ZigBee<sup>®</sup>
- GNSS - GPS, Galileo, GLONASS, BeiDou, QZSS
- Automotive, Industrial, Commercial, Enterprise

**TABLE 1. ELECTRICAL SPECIFICATIONS**

Parameter	Value		
	CSE-SBRM-152-SBRM	CSE-SBRM-305-SBRM	CSE-SBRM-610-SBRM
Insertion Loss (dB max)	-0.53	-0.89	-1.56
VSWR (max)	1.4		
Impedance	50 $\Omega$		
Insulation Resistance	500 M $\Omega$ min.		

## ORDERING INFORMATION

Part Number	Description
CSE-SBRM-152-SBRM	SMB plug (female socket) to SMB plug (female socket) on 152.4 mm (6.0 in) of RG-316/U coaxial cable
CSE-SBRM-305-SBRM	SMB plug (female socket) to SMB plug (female socket) on 304.8 mm (12.0 in) of RG-316/U coaxial cable
CSE-SBRM-610-SBRM	SMB plug (female socket) to SMB plug (female socket) on 609.6 mm (24.0 in) of RG-316/U coaxial cable

Available from Linx Technologies and select distributors and representatives.

## PRODUCT DIMENSIONS

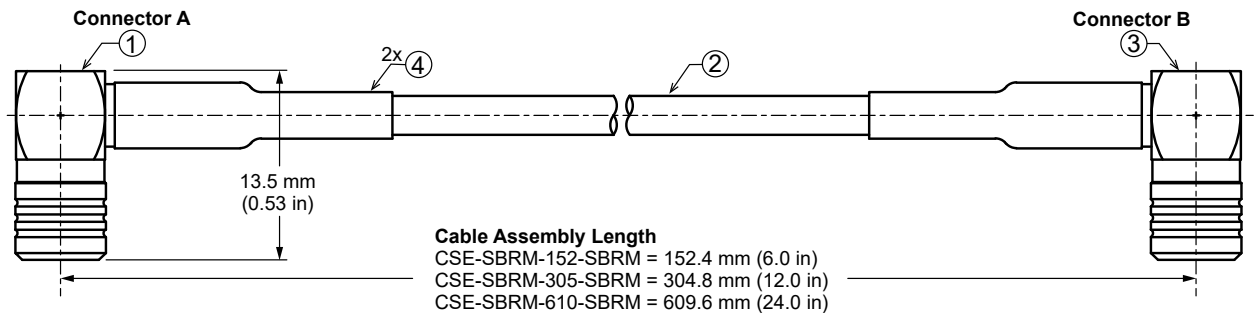

Figure 1. Product Dimensions for the CSE-SBRM-ccc-SBRM Cable Assembly

## TABLE 2. CABLE ASSEMBLY COMPONENTS

Item #	Description	Material	Finish
1	Connector, SMB right angle plug (female socket)	Brass	Gold
2	RG-316/U coaxial cable	RG-316/U	-
3	Connector, SMB right angle plug (female socket)	Brass	Gold
4	Heat Shrink Tubing	PTFE	Black

## TABLE 3. CABLE ASSEMBLY MECHANICAL SPECIFICATIONS

Parameter	Connector A	Connector B
Fastening Type	Snap-on coupling	Snap-on coupling
Recommended Torque	-	-
Coupling Nut Retention	-	-
Connector Durability	500 cycles min.	500 cycles min.
Weight	CSE-SBRM-152-SBRM = 8.9 g (0.31 oz) CSE-SBRM-305-SBRM = 11.0 g (0.39 oz) CSE-SBRM-610-SBRM = 15.5 g (0.55 oz)	

## COAXIAL CABLE SPECIFICATIONS

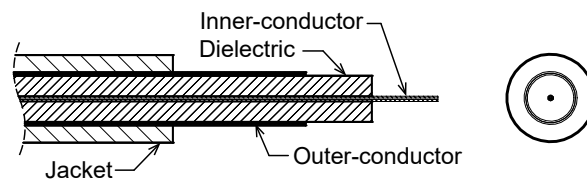

Figure 2. Coaxial Cable Cutaway Diagram

**TABLE 4. COAXIAL CABLE MATERIAL SPECIFICATIONS FOR RG-316/U**

RG-316/U Coax	Material	Dimensions
Inner-Conductor	Copper plated steel, 7 strand, 0.175 mm/conductor	Ø0.53 mm (0.020 in)
Dielectric	PTFE	Ø1.53 mm (0.06 in)
Outer-Conductor	Silver plated copper braid, Coverage 92.3%	Ø1.71 mm (0.067 in)
Jacket	FEP	Ø2.53 mm (0.100 in)

**TABLE 5. COAXIAL CABLE ELECTRICAL AND PHYSICAL SPECIFICATIONS FOR RG-316/U**

Parameter	Value		
Rated Temp Voltage	105 °C 30 V		
Conductor Resistance	281 Ω/km 20 °C		
Insulation Resistance	3000 M Ω-km min.		
Dielectric Strength	AC 1000 V/Minute		
Spark Test	2.0 kV		
Insulation	Unaged	Tensile Strength	2500 psi min. (1.76 kg/mm <sup>2</sup> )
		Elongation	200% min.
	Aged	Tensile Strength	Unaged min. 75% (168 hrs x 232 °C)
		Elongation	Unaged min. 75% (168 hrs x 232 °C)
Jacket	Unaged	Tensile Strength	2500 psi min. (1.76 kg/mm <sup>2</sup> )
		Elongation	200% min.
	Aged	Tensile Strength	Unaged min. 75% (168 hrs x 232 °C)
		Elongation	Unaged min. 75% (168 hrs x 232 °C)
Nominal Impedance	50 ± 3 Ω		
Nominal Capacitance	95.8 pF/m		
Nominal Velocity of Propagation	69.5%		
VSWR (0 to 6 GHz)	≤ 1.3		
Minimum Inside Bend radius	25.4 mm (1.0 in)		

**CABLE ASSEMBLY PERFORMANCE**

Table 6 shows insertion loss and VSWR values for the CSE-SBRM-ccc-SBRM cable assemblies at commonly used frequencies.

Insertion loss is the loss of signal power (gain) resulting from the insertion of a device in a transmission line. VSWR describes how efficiently power is transmitted through the cable assembly. A lower VSWR value indicates better performance at a given frequency.

**TABLE 6. INSERTION LOSS AND VSWR FOR THE CSE-SBRM-CCC-SBRM CABLE ASSEMBLIES**

Band	Low-Band Cellular/ISM/LPWA	GNSS	Midband Cellular	WiFi/ISM
Frequency Range	400 MHz to 960 MHz	1164 MHz to 1609 MHz	1427 MHz to 5000 MHz	2.4 GHz
Cable Assembly CSE-SBRM-152-SBRM				
Insertion Loss (dB max)	-0.21	-0.27	-0.53	-0.34
VSWR (max)	1.1	1.1	1.3	1.1
Cable Assembly CSE-SBRM-305-SBRM				
Insertion Loss (dB max)	-0.36	-0.46	-0.89	-0.55
VSWR (max)	1.1	1.1	1.4	1.1
Cable Assembly CSE-SBRM-610-SBRM				
Insertion Loss (dB max)	-0.60	-0.78	-1.56	-0.99
VSWR (max)	1.1	1.1	1.4	1.1

---

## PACKAGING INFORMATION

The CSE-SBRM-ccc-SBRM cable assembly is packaged in a clear plastic bag, in quantities of 50 pcs. Distribution channels may offer alternative packaging options.

### TE TECHNICAL SUPPORT CENTER

USA:	+1 (800) 522-6752
Canada:	+1 (905) 475-6222
Mexico:	+52 (0) 55-1106-0800
Latin/S. America:	+54 (0) 11-4733-2200
Germany:	+49 (0) 6251-133-1999
UK:	+44 (0) 800-267666
France:	+33 (0) 1-3420-8686
Netherlands:	+31 (0) 73-6246-999
China:	+86 (0) 400-820-6015

### te.com

TE Connectivity, TE, TE connectivity (logo), Linx and Linx Technologies are trademarks owned or licensed by the TE Connectivity Ltd. family of companies. All other logos, products and/or company names referred to herein might be trademarks of their respective owners.

The information given herein, including drawings, illustrations and schematics which are intended for illustration purposes only, is believed to be reliable. However, TE Connectivity makes no warranties as to its accuracy or completeness and disclaims any liability in connection with its use. TE Connectivity's obligations shall only be as set forth in TE Connectivity's Standard Terms and Conditions of Sale for this product and in no case will TE Connectivity be liable for any incidental, indirect or consequential damages arising out of the sale, resale, use or misuse of the product. Users of TE Connectivity products should make their own evaluation to determine the suitability of each such product for the specific application.

TE Connectivity warrants to the original end user customer of its products that its products are free from defects in material and workmanship. Subject to conditions and limitations TE Connectivity will, at its option, either repair or replace any part of its products that prove defective because of improper workmanship or materials. This limited warranty is in force for the useful lifetime of the original end product into which the TE Connectivity product is installed. Useful lifetime of the original end product may vary but is not warranted to exceed one (1) year from the original date of the end product purchase.

©2022 TE Connectivity. All Rights Reserved.

11/22 Original

## X-ON Electronics

Largest Supplier of Electrical and Electronic Components

*Click to view similar products for [RF Cable Assemblies](#) category:*

*Click to view products by [Linx Technologies](#) manufacturer:*

Other Similar products are found below :

[73-6352-10](#) [73-6353-3](#) [73-6364-6](#) [MDM-21SH011F](#) [R285001001](#) [R288940004](#) [145111-05-12.00](#) [1661-C-24](#) [1801171170914KE](#)  
[24P104C24J1-012](#) [24P104C24P1-018](#) [24P204C24J1-003](#) [172-2150-EX](#) [FCB-3030-ALT](#) [21117-046](#) [21117-050](#) [PCX-24-50](#) [24P103C24P2-](#)  
[003](#) [PTWY-24-78](#) [R284008001](#) [R285001021](#) [R288940003](#) [R288940008](#) [R288940034](#) [MDM-21PH006P-A174](#) [4814-BB-24](#) [5260-72](#) [DLP-](#)  
[COAX1](#) [4814-K-48](#) [115101-09-06.00](#) [MXHT83QE3000](#) [73-6351-25](#) [73-6352-3](#) [73-6353-25](#) [81-6201-1600](#) [GD0BQ0BQ024.0](#) [1-3636-600-](#)  
[5210](#) [R284C0351060](#) [R288940009](#) [R284C0351028](#) [MDM-15SH006A](#) [PT82NSMA](#) [73-6353-10](#) [Minibend-9](#) [BNC TO SMA Cable](#)  
[MIKROE-274](#) [Minibend-10](#) [Microbend MTR-11](#) [PT815NN](#) [MF53/1x8A\\_21MXP/11SK/305](#)