

Features

- Wide operating voltage (V_{1mA}) range from 18V to 750V
- Fast responding to transient over-voltage
- Large absorbing transient energy capability
- Low clamping ratio and no follow-on current
- Meets MSL level1, per J-STD-020
- Operating temperature: $-40^{\circ}\text{C} \sim +85^{\circ}\text{C}$
- Storage Temperature: $-40^{\circ}\text{C} \sim +125^{\circ}\text{C}$

Applications

- Transistor, diode, IC, SCR or SCR semiconductor protection
- Surge protection in consumer electronics
- Surge protection in industrial electronics
- Surge protection in electronic home appliances, gas and petroleum appliances
- Relay and electromagnetic valve surge absorption

Part Number Code and Marking Code

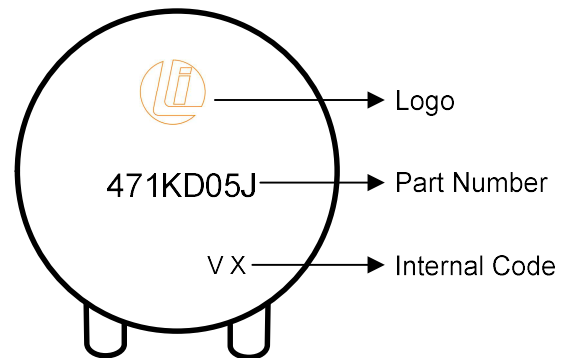
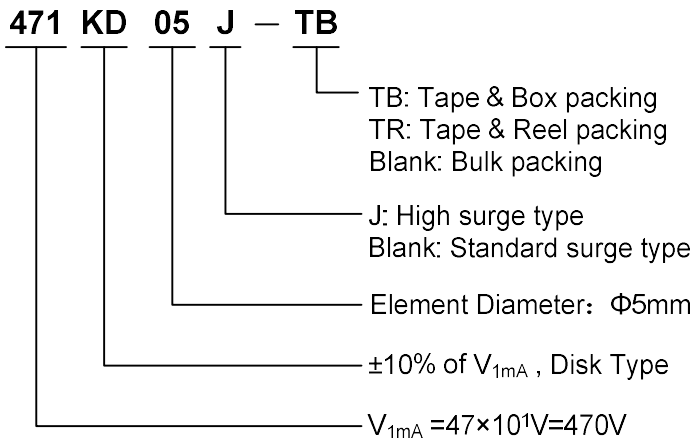

Dimensions

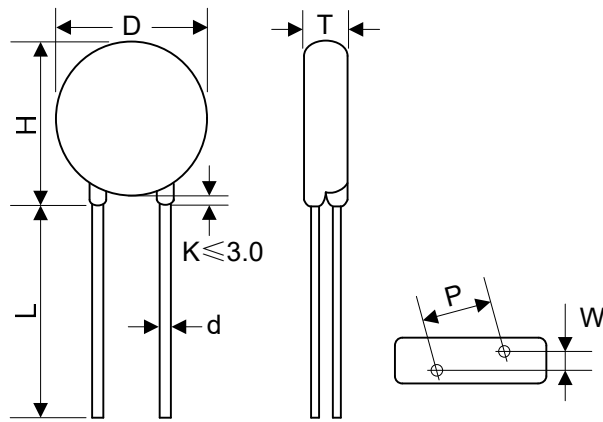

Straight leads

Item	D	H	L	d	P	T	W
Dimension (mm)	5.0~7.5	5.5~10.0	≥20.0	0.6±0.05	5.0±0.8	Refer to the following table	

Model	T	W	Model	T	W	Model	T	W
180K	1.5~4.5	1.3±0.8	121K	1.9~4.5	2.0±0.8	391K	2.5~5.4	2.6±0.8
220K	1.6~4.6	1.4±0.8	151K	1.7~4.8	1.6±0.8	431K	2.7~5.7	2.8±0.8
270K	1.6~4.7	1.6±0.8	181K	1.8~4.3	1.7±0.8	471K	2.8~6.0	3.0±0.8
330K	1.7~4.9	1.5±0.8	201K	1.9~4.4	1.8±0.8	511K	2.9~6.2	3.2±0.8
390K	1.6~4.8	1.6±0.8	221K	2.0~4.5	1.9±0.8	561K	3.1~6.5	3.4±0.8
470K	1.7~4.9	1.7±0.8	241K	2.1~4.6	2.0±0.8	621K	3.3~6.5	3.7±0.8
560K	1.8~5.0	1.9±0.8	271K	2.1~4.9	2.2±0.8	681K	3.5~6.8	4.0±0.8
680K	1.9~5.2	2.2±0.8	301K	2.2~5.0	2.3±0.8	751K	3.8~6.9	4.1±0.8
820K	1.6~4.1	1.6±0.8	331K	2.2~5.1	2.3±0.8			
101K	1.9~4.3	1.8±0.8	361K	2.4~5.2	2.5±0.8			

Electrical Characteristics

Model	Varistor Voltage	Maximum Allowable Voltage		Maximum Clamping Voltage		Surge Current	Maximum Energy (10/1000 μ s)	Maximum Leakage Current @83% of V_{1mA}	Rated Power	Typical Capacitance (Reference)
	V_{1mA} (V)	V_{AC} (V)	V_{DC} (V)	I_P (A)	V_C (V)	I (A)	E (J)	I_R (μ A)	P (W)	@1KHz (pF)
180KD05	18(15~21.6)	11	14	1	40	100	0.4	50	0.01	1400
180KD05J	18(15~21.6)	11	14	1	40	250	0.6	50	0.01	1400
220KD05	22(19.5~26)	14	18	1	48	100	0.5	50	0.01	1150
220KD05J	22(19.5~26)	14	18	1	48	250	0.7	50	0.01	1150
270KD05	27(24~31)	17	22	1	60	100	0.6	50	0.01	930
270KD05J	27(24~31)	17	22	1	60	250	0.9	50	0.01	930
330KD05	33(29.5~36.5)	20	26	1	73	100	0.8	50	0.01	760
330KD05J	33(29.5~36.5)	20	26	1	73	250	1.1	50	0.01	760
390KD05	39(35~43)	25	31	1	80	100	0.9	50	0.01	640
390KD05J	39(35~43)	25	31	1	80	250	1.2	50	0.01	640
470KD05	47(42~52)	30	38	1	104	100	1.1	50	0.01	530
470KD05J	47(42~52)	30	38	1	104	250	1.5	50	0.01	530
560KD05	56(50~62)	35	45	1	123	100	1.3	50	0.01	450
560KD05J	56(50~62)	35	45	1	123	250	1.8	50	0.01	450
680KD05	68(61~75)	40	56	1	145	100	1.6	50	0.01	370
680KD05J	68(61~75)	40	56	1	145	250	2.2	50	0.01	370
820KD05	82(74~90)	50	65	5	150	400	2.5	25	0.1	300
820KD05J	82(74~90)	50	65	5	150	800	4.0	25	0.1	300
101KD05	100(90~110)	60	85	5	177	400	3.0	25	0.1	250
101KD05J	100(90~110)	60	85	5	177	800	4.1	25	0.1	250
121KD05	120(108~132)	75	100	5	210	400	4.0	25	0.1	210
121KD05J	120(108~132)	75	100	5	210	800	4.9	25	0.1	210
151KD05	150(135~165)	95	125	5	260	400	4.1	25	0.1	165
151KD05J	150(135~165)	95	125	5	260	800	6.5	25	0.1	165
181KD05	180(162~198)	115	150	5	320	400	4.9	25	0.1	140
181KD05J	180(162~198)	115	150	5	320	800	7.5	25	0.1	140
201KD05	200(180~220)	130	170	5	355	400	6.5	25	0.1	125
201KD05J	200(180~220)	130	170	5	355	800	8.5	25	0.1	125

Electrical Characteristics

Model	Varistor Voltage	Maximum Allowable Voltage		Maximum Clamping Voltage		Surge Current	Maximum Energy (10/1000 μ s)	Maximum Leakage Current @83% of V_{1mA}	Rated Power	Typical Capacitance (Reference)
	V_{1mA} (V)	V_{AC} (V)	V_{DC} (V)	I_P (A)	V_C (V)	I (A)	E (J)	I_R (μ A)	P (W)	@1KHz (pF)
221KD05	220(198~242)	140	180	5	380	400	7.5	25	0.1	110
221KD05J	220(198~242)	140	180	5	380	800	9.0	25	0.1	110
241KD05	240(216~264)	150	200	5	415	400	8.0	25	0.1	100
241KD05J	240(216~264)	150	200	5	415	800	10.5	25	0.1	100
271KD05	270(243~297)	175	225	5	475	400	8.5	25	0.1	95
271KD05J	270(243~297)	175	225	5	475	800	11.0	25	0.1	95
301KD05	300(270~330)	190	250	5	520	400	9.0	25	0.1	85
301KD05J	300(270~330)	190	250	5	520	800	12.0	25	0.1	85
331KD05	330(297~363)	210	275	5	570	400	9.5	25	0.1	75
331KD05J	330(297~363)	210	275	5	570	800	13.0	25	0.1	75
361KD05	360(324~396)	230	300	5	620	400	10.0	25	0.1	70
361KD05J	360(324~396)	230	300	5	620	800	16.0	25	0.1	70
391KD05	390(351~429)	250	320	5	675	400	12.0	25	0.1	65
391KD05J	390(351~429)	250	320	5	675	800	17.0	25	0.1	65
431KD05	430(387~473)	275	350	5	745	400	13.0	25	0.1	60
431KD05J	430(387~473)	275	350	5	745	800	20.0	25	0.1	60
471KD05	470(423~517)	300	385	5	810	400	15.0	25	0.1	55
471KD05J	470(423~517)	300	385	5	810	800	21.0	25	0.1	55
511KD05	510(459~561)	320	415	5	845	400	16.0	25	0.1	50
511KD05J	510(459~561)	320	415	5	845	800	22.5	25	0.1	50
561KD05	560(504~616)	350	460	5	920	400	16.8	25	0.1	45
561KD05J	560(504~616)	350	460	5	920	800	24.0	25	0.1	45
621KD05	620(558~682)	385	505	5	1025	400	17.7	25	0.1	40
621KD05J	620(558~682)	385	505	5	1025	800	25.0	25	0.1	40
681KD05	680(612~748)	420	560	5	1120	400	21.0	25	0.1	35
681KD05J	680(612~748)	420	560	5	1120	800	29.0	25	0.1	35
751KD05	750(675~825)	460	615	5	1240	400	22.4	25	0.1	30
751KD05J	750(675~825)	460	615	5	1240	800	32.0	25	0.1	30

Electrical Ratings

Items	Test Condition/Description	Requirement
Varistor Voltage	The voltage between two terminals with the specified measuring current 1mA.DC applied is called Vb.	To meet the Specified value
Maximum Allowable Voltage	The recommended maximum sine wave voltage (RMS) or the Maximum DC voltage can be applied continuously.	
Maximum Clamping Voltage	The maximum voltage between two terminals with the specification standard impulse current. Applied waveform: 8/20μs	
Surge Current	The maximum current within the varistor voltage change of ±10% with the standard impulse current (8/20μs) applied one time.	
Energy	The maximum energy within the varistor voltage change of ±10% when one impulse of 10/1000μs is applied.	
Leakage Current	The current through the varistor when 0.83V _{1mA} is applied to both end.	
Rated Power	The maximum average power that can be applied within the specified ambient temperature.	
Varistor Voltage Temp. Coefficient	$\left \frac{V_{1mA@85^{\circ}C} - V_{1mA@25^{\circ}C}}{V_{1mA@25^{\circ}C}} \times \frac{1}{60} \times 100\% (\%/^{\circ}C) \right $	≤0.05%/°C
	$\left \frac{V_{1mA@-40^{\circ}C} - V_{1mA@25^{\circ}C}}{V_{1mA@25^{\circ}C}} \times \frac{1}{65} \times 100\% (\%/^{\circ}C) \right $	
Surge Life	The change of V _{1mA} shall be measured after the impulse listed below which is applied 10,000 times continuously with the interval of ten seconds at room temperature.	
	05D series	180K to 680K 10A (8/20μs)
		820K to 751K 20A (8/20μs)
		$ \Delta V_{1mA}/V_{1mA} \leq 10\%$

Mechanical Characteristics and Reliability

Items	Test conditions / Methods			Specifications
Tensile Strength of Terminals	Gradually applying the force specified and keeping the unit fixed for 10±1 sec.			No visible damage $ \Delta V_{1mA}/V_{1mA} \leq 5\%$
	Terminal diameter (mm)		Force (kg)	
	0.5<d≤0.8		1.0	
	0.8<d≤1.25		2.0	
	1.25<d		4.0	
Bending Strength of Terminals	Hold specimen and apply the force specified below to each lead. Bend the specimen to 90°, then return to the original position. Repeat the procedure in the opposite direction.			No visible damage $ \Delta V_{1mA}/V_{1mA} \leq 5\%$
	Terminal diameter (mm)		Force (kg)	
	0.5<d≤0.8		0.5	
	0.8<d≤1.25		1.0	
	1.25<d		2.0	
Vibration	Frequency range: 10~55 Hz Amplitude: 0.75mm or 98m/s ² Direction: 3 mutually perpendicular directions, 2hrs each.			No visible damage $ \Delta V_{1mA}/V_{1mA} \leq 5\%$
Solder ability	Solder Temp: 245±5°C Dipping Time: 2±0.5 sec			At least 95% of terminal electrode is covered by new solder
Resistance to Soldering Heat	Solder Temp: 260±5°C Dipping Time: 10±1 sec			No visible damage $ \Delta V_{1mA}/V_{1mA} \leq 10\%$
High Temperature Storage	Ambient Temp: 125±2°C Duration: 1000hrs			$ \Delta V_{1mA}/V_{1mA} \leq 5\%$
Low Temperature Storage	Ambient Temp: -40±2°C Duration: 1000hrs			$ \Delta V_{1mA}/V_{1mA} \leq 5\%$
Humidity	Ambient Temp: 40±2°C, 90~95% R.H. Duration: 1000hrs			$ \Delta V_{1mA}/V_{1mA} \leq 5\%$
Temperature Cycle	The conditions shown below shall be repeated 5 cycles			No visible damage $ \Delta V_{1mA}/V_{1mA} \leq 5\%$
	Step	Temperature (°C)	Period (minutes)	
	1	-40±3	30±3	
	2	Room temperature	15±3	
	3	125±3	30±3	
	4	Room temperature	15±3	
High Temperature Load	Ambient Temp: 85±2°C Duration: 1000hrs Load: Max. Allowable Voltage In AC eara.			$ \Delta V_{1mA}/V_{1mA} \leq 10\%$
Damp Heat Load	Ambient Temp: 40±2°C, 90~95% R.H. Duration: 1000hrs Load: Max. Allowable Voltage			No visible damage $ \Delta V_{1mA}/V_{1mA} \leq 10\%$
Voltage Proof	Metal balls method, 2500Vac 1 min.			No visible damage

Soldering Recommendation

Wave Lead Free Soldering Recommendation

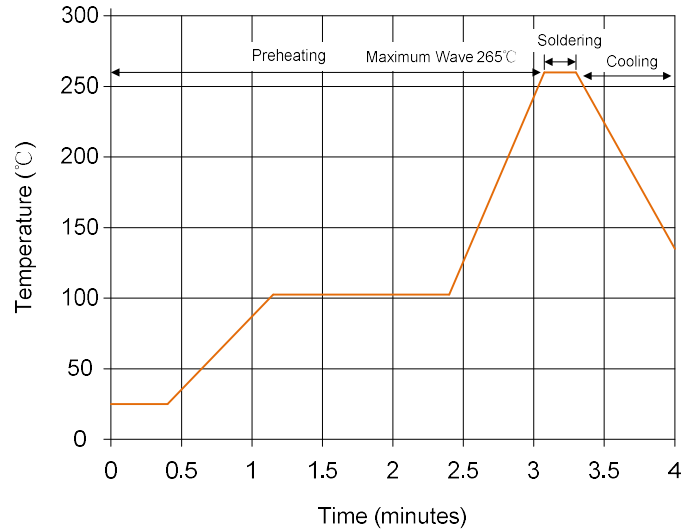

Peak Temperature: 265°C

Dipping Time: 10 seconds (max.)

Soldering: 1 time

Recommendation Reworking Conditions with Soldering Iron

Temperature of Soldering Iron-tip: 360°C (max.)

Soldering Time: 3 seconds (max.)

Distance from Varistor: 2mm (min.)

Power Derating Curve

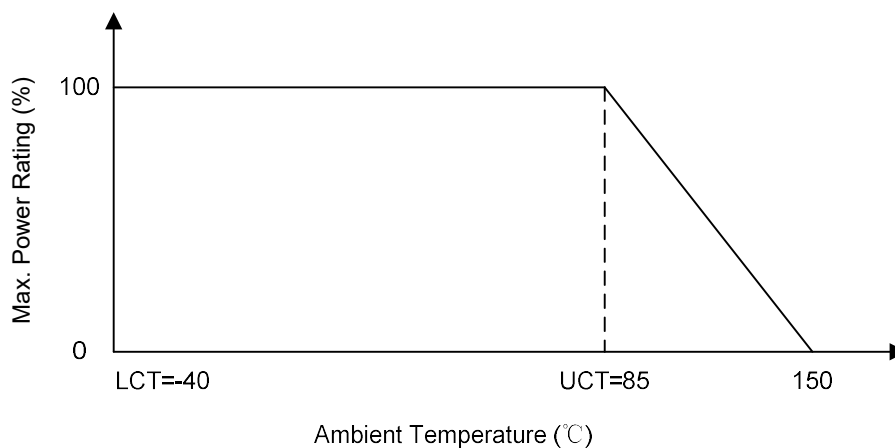

Maximum Surge Current Derating Curve

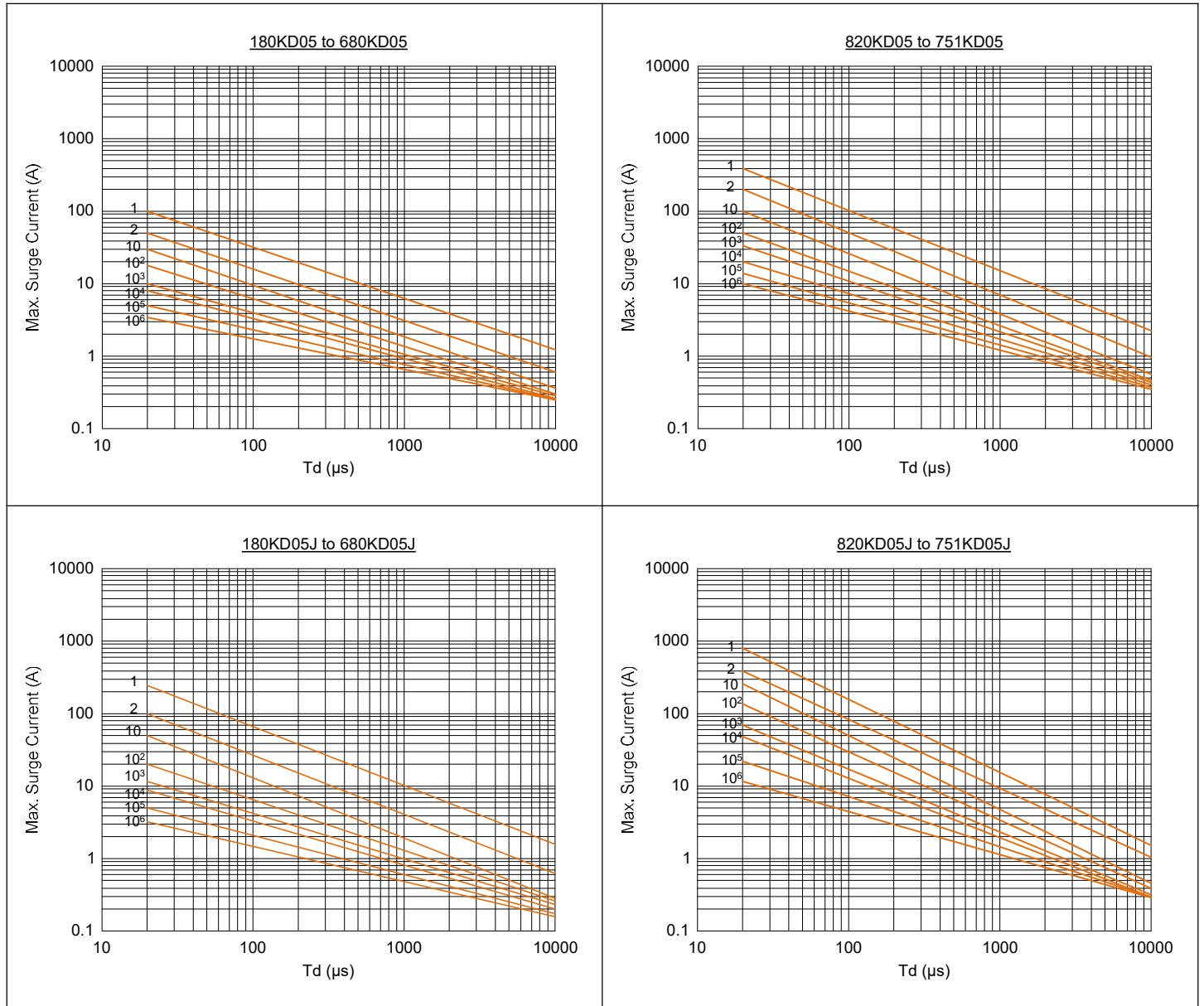

Maximum Leakage Current and Maximum Clamping Voltage Curve

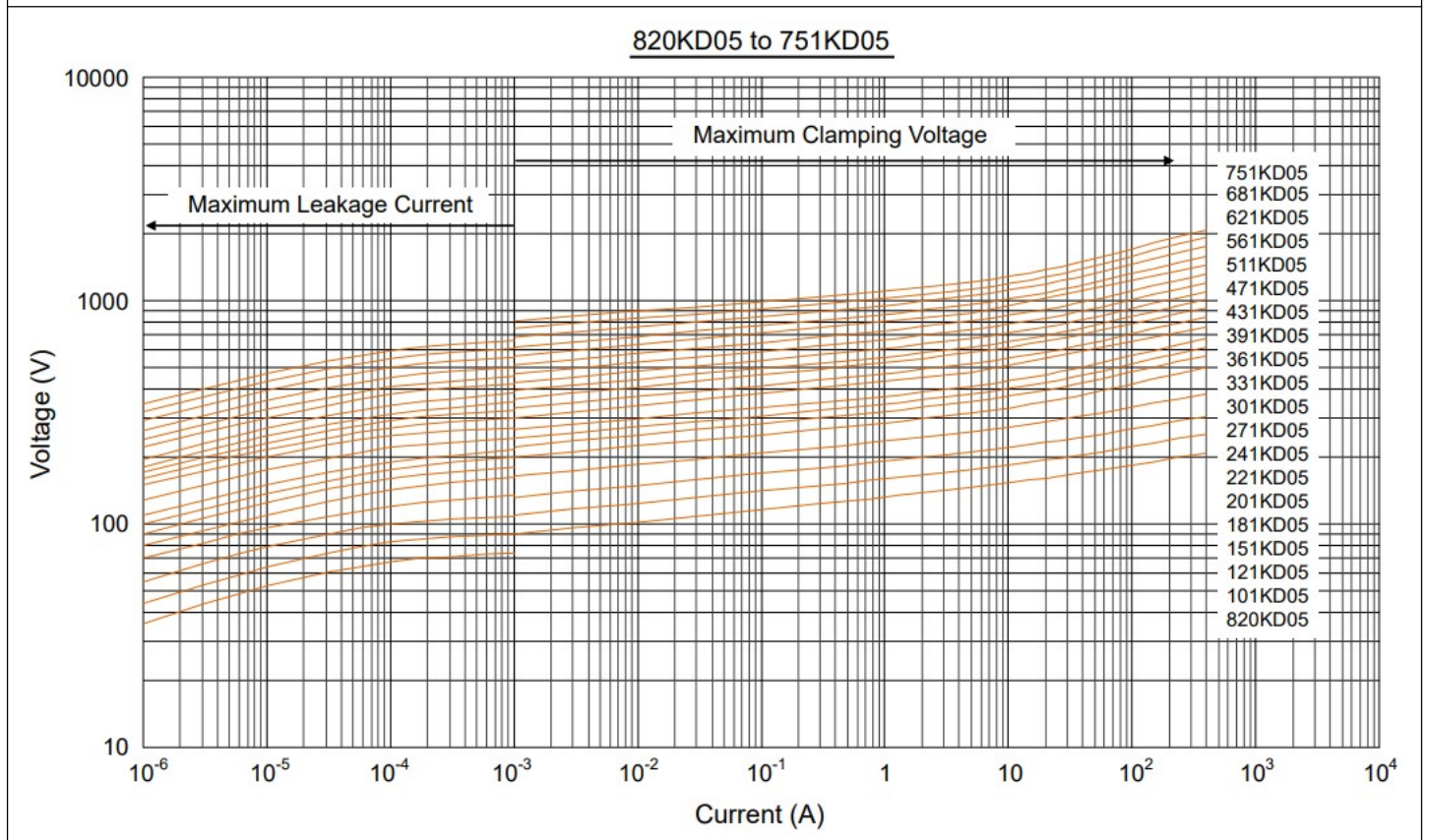
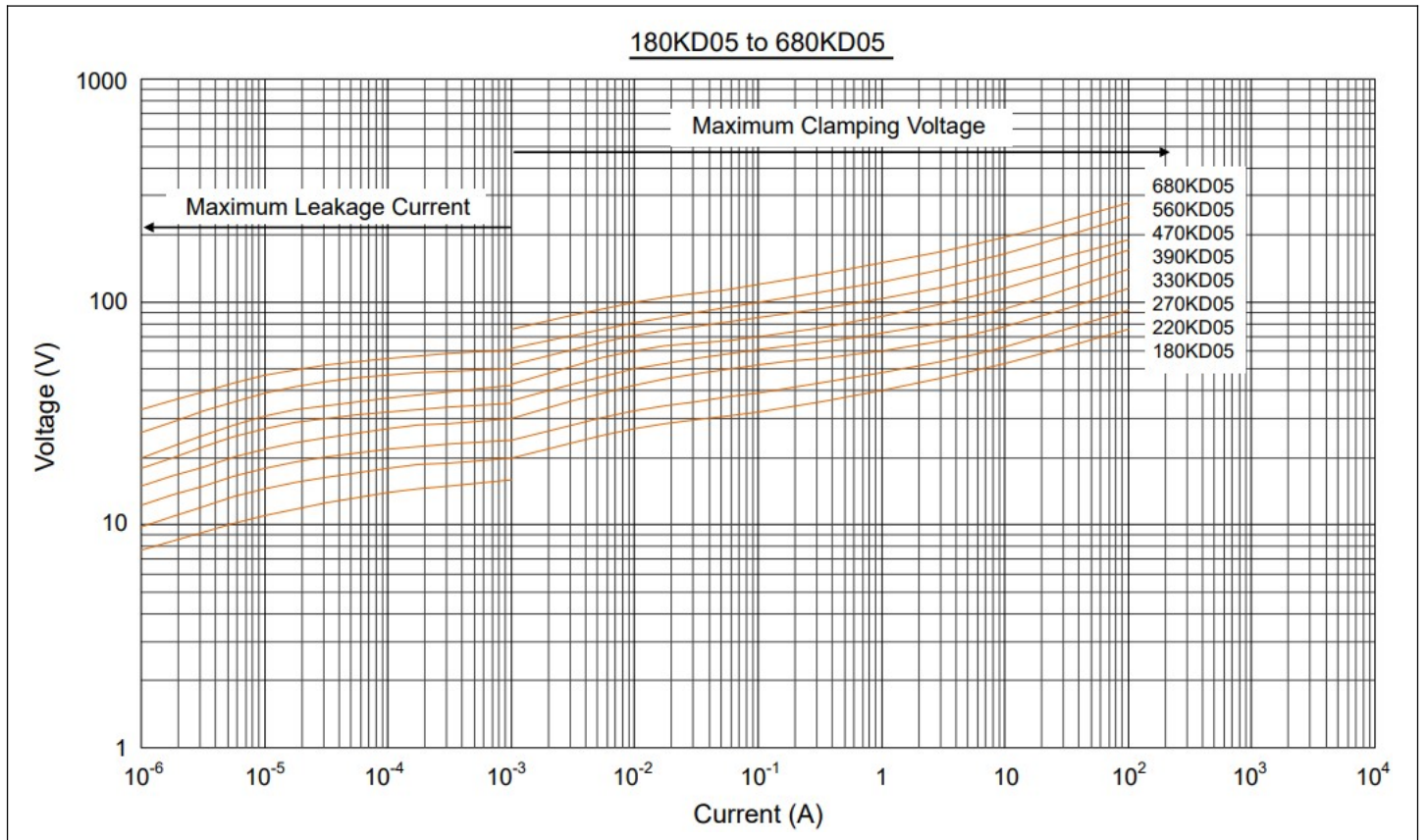

Maximum Leakage Current and Maximum Clamping Voltage Curve

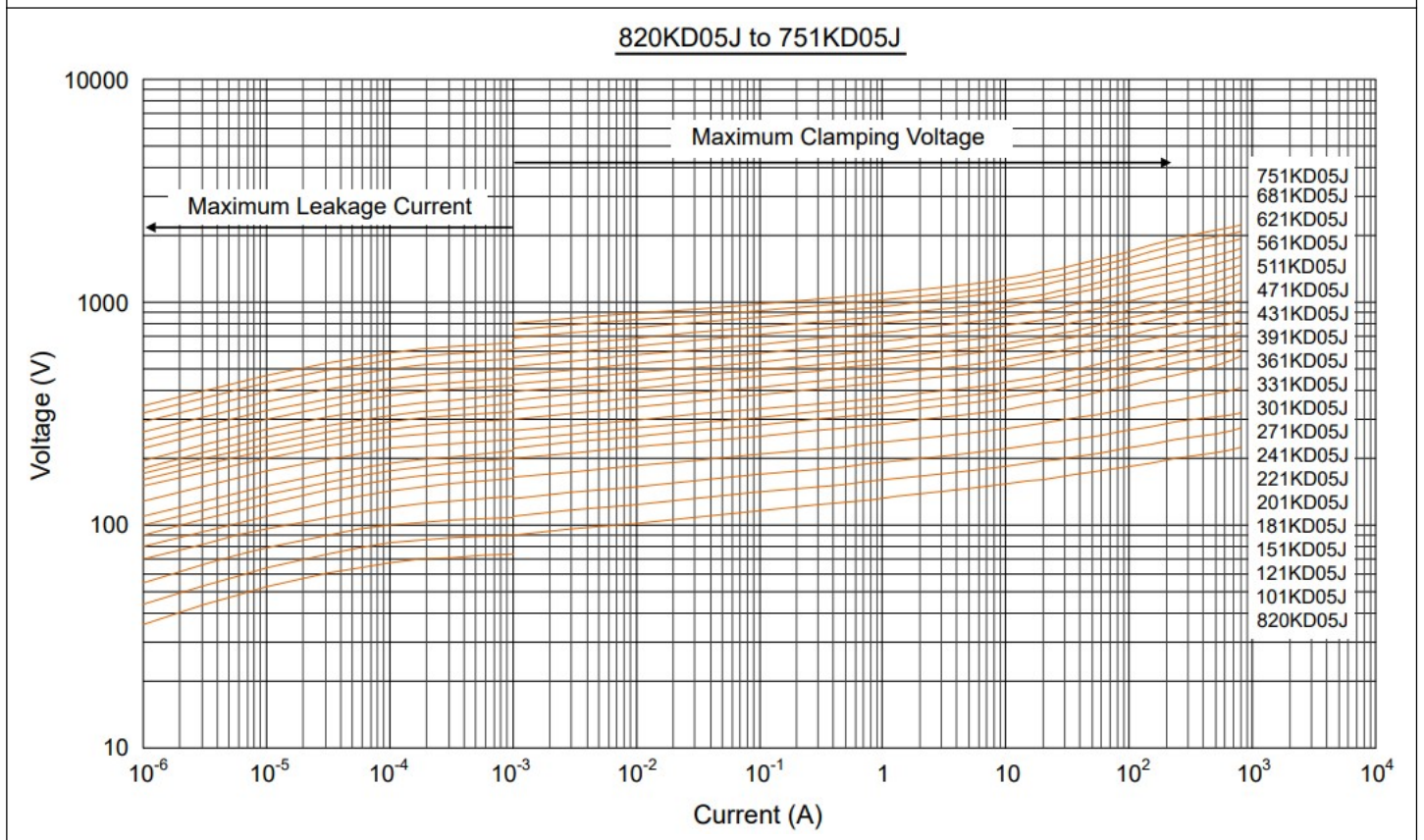
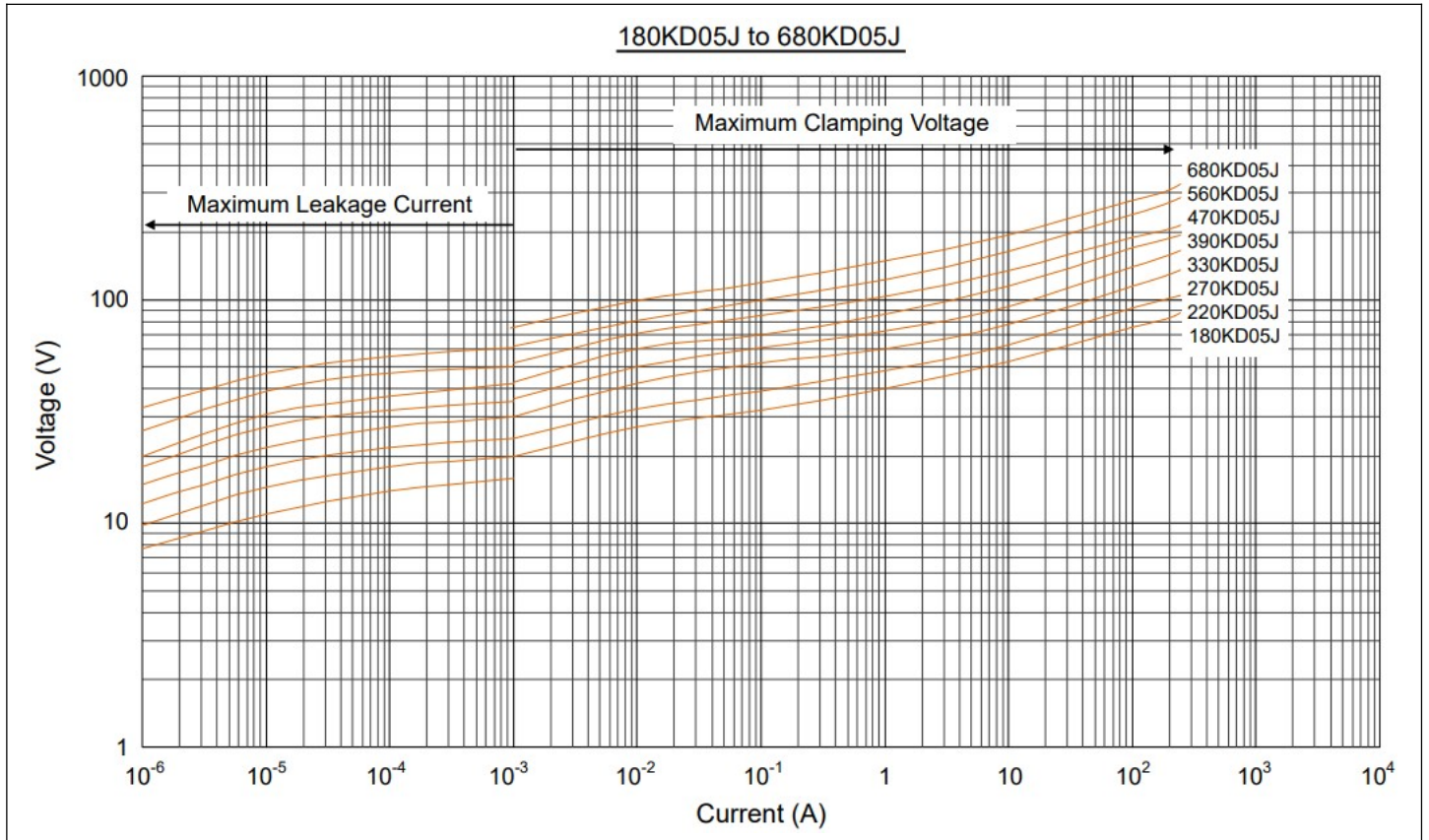

Taping Packaging

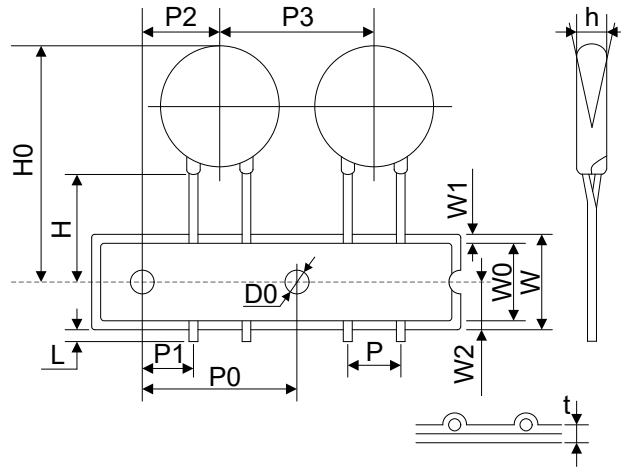

Item	P	P0	P1	P2	P3	W	W0	W1
Dimensions(mm)	5.0±0.8	12.7±0.3	3.85±0.7	6.35±1.3	12.7±1.0	18.0±1.0	12.0±1.0	3.0max.
Item	W2	H	H0	D0	L	h	t	
Dimensions(mm)	9.0±0.5	20.0±2.0	32max.	4.0±0.2	1.0max.	0±2	0.6±0.3	

Tape & Box

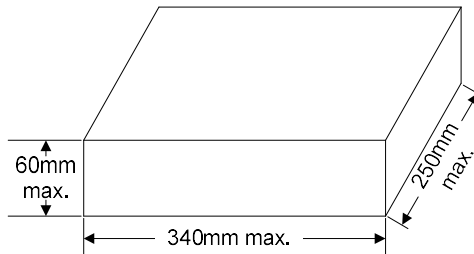

Tape & Reel

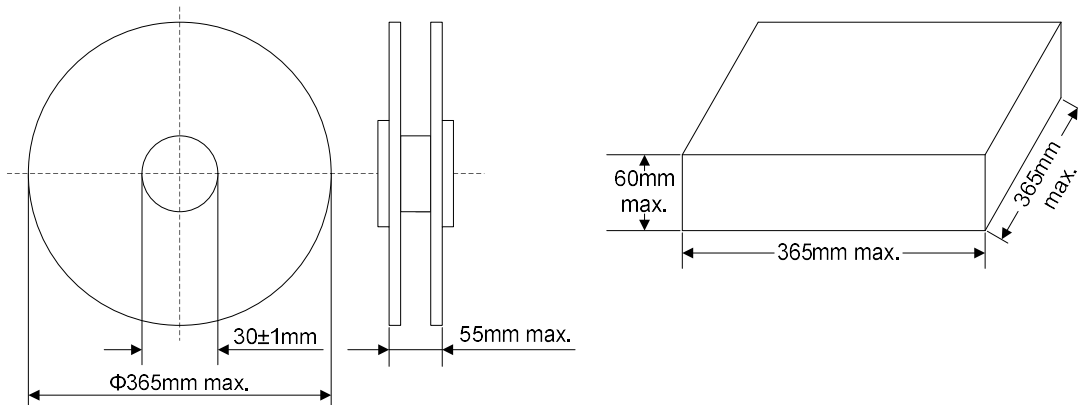

Quantity

Packaging	Model	Quantity	
Bulk	180K~751K	1000pcs/bag	2 bags/box
Tape & Box	180K~391K	1500pcs/box	/
	431K~751K	1000pcs/box	/
Tape & Reel	180K~391K	2000pcs/reel	1 reel/box
	431K~751K	1500pcs/reel	1 reel/box

X-ON Electronics

Largest Supplier of Electrical and Electronic Components

Click to view similar products for [Varistors](#) category:

Click to view products by [Liown](#) manufacturer:

Other Similar products are found below :

[R71ZOV151HC](#) [B72205S271K111](#) [B72214S110K151](#) [B72214S251K151](#) [B72540E250K62](#) [NTE1V020](#) [NTE1V130](#) [25FN511K](#)
[S10K11G5S5](#) [ERZ-C14DK361U](#) [ERZ-C20DK221U](#) [ERZ-C32CK201B](#) [207869-1](#) [AS-13](#) [B72214S200K551](#) [B72280B112K1](#) [B72540E](#)
[350K 62](#) [B72590D360A60](#) [B72650M301K93](#) [B72670M1140K72](#) [TVZ18EC271KBS](#) [TVZ20EB911KBS](#) [TVZ25D201KBS](#) [TVZ25D241KBS](#)
[VDRH20X230BSE](#) [VZ07D220KBS](#) [VZ40D241KQ-N](#) [VZ40D241K](#) [VZ25D511KBS-N](#) [VZ20E511KBSX](#) [VZ20E221KBSX](#)
[VZ10D471KBS-N](#) [ERZ-V20R221](#) [20A9FN241K](#) [B72205S350K211](#) [B72214S110K551](#) [B72510E140K62](#) [B72650M350K72](#)
[TVZ25DN271KBS](#) [TVZ25D301KBS](#) [TVZ20EC911KBS](#) [TVZ20EBN911KBS](#) [TVZ18EC471KBS](#) [B72220S350K101](#) [B72540E300K62](#)
[TND10V-271KB00AAA0](#) [NTE1V030](#) [NTE1V275](#) [NTE2V015](#) [NTE2V035](#)