

Description

The P4KE series is designed specifically to protect sensitive electronic equipment from voltage transients induced by lightning and other transient voltage events.

Features

- Halogen free and RoHS compliant
- Low incremental surge resistance
- Excellent clamping capability
- 400W peak pulse power capability at 10/1000 μ s waveform, repetition rate (duty cycle): 0.01%
- Fast response time
- Typical I_R less than 1 μ A above 12V devices
- High Temperature soldering guaranteed: 265 $^{\circ}$ C/10 seconds/.375", (9.5mm) lead length, 5lbs (2.3kg) tension
- Plastic package has underwriters laboratory flammability 94V-0
- Meet MSL level1, per J-STD-020
- IEC-61000-4-2 ESD 30kV(Air), 30kV (Contact)
- Unit Weight: 0.33g



Applications

TVS components are ideal for the protection of I/O Interfaces, VCC bus and other vulnerable circuits used in telecom, computer, Industrial and consumer electronic applications.

Maximum Ratings and Characteristics ($T_A=25^{\circ}$ C)

| Rating | Symbol | Value |
|---|-----------------|---------------------------------------|
| Peak pulse power dissipation at 10/1000 μ s waveform (Note1, Fig.1) | P_{PPM} | 400W |
| Peak pulse current of at 10/1000 μ s waveform (Note 1, Fig.3) | I_{PPM} | See Table(A) |
| Steady state power dissipation at $T_L=50^{\circ}$ C (Fig.5) | $P_{M(AV)}$ | 1.5W |
| Maximum Instantaneous Forward Voltage at 25A for Unidirectional Only | V_F | 3.5V/5.0V |
| Peak forward surge current, 8.3ms single half sine-wave superimposed on rated load, (JEDEC Method) (Note2, Fig.6) | I_{FSM} | 40A |
| Operating junction and Storage Temperature Ranges | T_J, T_{STG} | -55 $^{\circ}$ C to +150 $^{\circ}$ C |
| Typical thermal resistance junction to lead | $R_{\theta JL}$ | 20 $^{\circ}$ C/W |
| Typical thermal resistance junction to ambient | $R_{\theta JA}$ | 75 $^{\circ}$ C/W |

Notes:1. Non-repetitive current pulse, per Fig.3 and derating above $T_A=25^{\circ}$ C per Fig.2.

2. 8.3ms single half sine-wave or equivalent square wave, duty cycle=4 pulses per minutes maximum.

3. $V_F < 3.5V$ for single die parts and $V_F < 5.0V$ for stacked-die parts.

Electrical Characteristics (T_A=25°C)

| Part Number | | Reverse Stand-Off Voltage | Breakdown Voltage @I _T | | Test Current | Maximum Clamping Voltage @I _{PP} | Peak Pulse Current | Reverse Leakage @V _R |
|-------------|-----------|---------------------------|-----------------------------------|-------------------------|---------------------|---|---------------------|---------------------------------|
| Uni. | Bi. | V _R (V) | V _{B Min.} (V) | V _{B Max.} (V) | I _T (mA) | V _C (V) | I _{PP} (A) | I _R (μA) |
| P4KE6.8A | P4KE6.8CA | 5.80 | 6.45 | 7.14 | 10 | 10.5 | 39.0 | 1000 |
| P4KE7.5A | P4KE7.5CA | 6.40 | 7.13 | 7.88 | 10 | 11.3 | 36.3 | 500 |
| P4KE8.2A | P4KE8.2CA | 7.02 | 7.79 | 8.61 | 10 | 12.1 | 33.9 | 200 |
| P4KE9.1A | P4KE9.1CA | 7.78 | 8.65 | 9.55 | 1 | 13.4 | 30.6 | 50 |
| P4KE10A | P4KE10CA | 8.55 | 9.50 | 10.50 | 1 | 14.5 | 28.3 | 10 |
| P4KE11A | P4KE11CA | 9.40 | 10.50 | 11.60 | 1 | 15.6 | 26.3 | 5 |
| P4KE12A | P4KE12CA | 10.20 | 11.40 | 12.60 | 1 | 16.7 | 24.6 | 5 |
| P4KE13A | P4KE13CA | 11.10 | 12.40 | 13.70 | 1 | 18.2 | 22.5 | 1 |
| P4KE15A | P4KE15CA | 12.80 | 14.30 | 15.80 | 1 | 21.2 | 19.3 | 1 |
| P4KE16A | P4KE16CA | 13.60 | 15.20 | 16.80 | 1 | 22.5 | 18.2 | 1 |
| P4KE18A | P4KE18CA | 15.30 | 17.10 | 18.90 | 1 | 25.2 | 16.1 | 1 |
| P4KE20A | P4KE20CA | 17.10 | 19.00 | 21.00 | 1 | 27.7 | 14.8 | 1 |
| P4KE22A | P4KE22CA | 18.80 | 20.90 | 23.10 | 1 | 30.6 | 13.4 | 1 |
| P4KE24A | P4KE24CA | 20.50 | 22.80 | 25.20 | 1 | 33.2 | 12.3 | 1 |
| P4KE27A | P4KE27CA | 23.10 | 25.70 | 28.40 | 1 | 37.5 | 10.9 | 1 |
| P4KE30A | P4KE30CA | 25.60 | 28.50 | 31.50 | 1 | 41.4 | 9.9 | 1 |
| P4KE33A | P4KE33CA | 28.20 | 31.40 | 34.70 | 1 | 45.7 | 9.0 | 1 |
| P4KE36A | P4KE36CA | 30.80 | 34.20 | 37.80 | 1 | 49.9 | 8.2 | 1 |
| P4KE39A | P4KE39CA | 33.30 | 37.10 | 41.00 | 1 | 53.9 | 7.6 | 1 |
| P4KE43A | P4KE43CA | 36.80 | 40.90 | 45.20 | 1 | 59.3 | 6.9 | 1 |
| P4KE47A | P4KE47CA | 40.20 | 44.70 | 49.40 | 1 | 64.8 | 6.3 | 1 |
| P4KE51A | P4KE51CA | 43.60 | 48.50 | 53.60 | 1 | 70.1 | 5.8 | 1 |
| P4KE56A | P4KE56CA | 47.80 | 53.20 | 58.80 | 1 | 77.0 | 5.3 | 1 |
| P4KE62A | P4KE62CA | 53.00 | 58.90 | 65.10 | 1 | 85.0 | 4.8 | 1 |
| P4KE68A | P4KE68CA | 58.10 | 64.60 | 71.40 | 1 | 92.0 | 4.5 | 1 |

Electrical Characteristics (TA=25°C)

| Part Number | | Reverse Stand-Off Voltage | Breakdown Voltage @I _T | | Test Current | Maximum Clamping Voltage @I _{PP} | Peak Pulse Current | Reverse Leakage @V _R |
|-------------|-----------|---------------------------|-----------------------------------|-------------------------|---------------------|---|---------------------|---------------------------------|
| Uni. | Bi. | V _R (V) | V _{B Min.} (V) | V _{B Max.} (V) | I _T (mA) | V _C (V) | I _{PP} (A) | I _R (μA) |
| P4KE75A | P4KE75CA | 64.10 | 71.30 | 78.80 | 1 | 103.0 | 4.0 | 1 |
| P4KE82A | P4KE82CA | 70.10 | 77.90 | 86.10 | 1 | 113.0 | 3.6 | 1 |
| P4KE91A | P4KE91CA | 77.80 | 86.50 | 95.50 | 1 | 125.0 | 3.3 | 1 |
| P4KE100A | P4KE100CA | 85.50 | 95.00 | 105.0 | 1 | 137.0 | 3.0 | 1 |
| P4KE110A | P4KE110CA | 94.00 | 105.0 | 116.0 | 1 | 152.0 | 2.7 | 1 |
| P4KE120A | P4KE120CA | 102.00 | 114.00 | 126.0 | 1 | 165.0 | 2.5 | 1 |
| P4KE130A | P4KE130CA | 111.00 | 124.0 | 137.0 | 1 | 179.0 | 2.3 | 1 |
| P4KE150A | P4KE150CA | 128.00 | 143.0 | 158.0 | 1 | 207.0 | 2.0 | 1 |
| P4KE160A | P4KE160CA | 136.00 | 152.0 | 168.0 | 1 | 219.0 | 1.9 | 1 |
| P4KE170A | P4KE170CA | 145.00 | 162.0 | 179.0 | 1 | 234.0 | 1.8 | 1 |
| P4KE180A | P4KE180CA | 154.00 | 171.0 | 189.0 | 1 | 246.0 | 1.7 | 1 |
| P4KE200A | P4KE200CA | 171.00 | 190.0 | 210.0 | 1 | 274.0 | 1.5 | 1 |
| P4KE220A | P4KE220CA | 185.00 | 209.0 | 231.0 | 1 | 328.0 | 1.3 | 1 |
| P4KE250A | P4KE250CA | 214.00 | 237.0 | 263.0 | 1 | 344.0 | 1.2 | 1 |
| P4KE300A | P4KE300CA | 256.00 | 285.0 | 315.0 | 1 | 414.0 | 1.0 | 1 |
| P4KE350A | P4KE350CA | 300.00 | 332.0 | 368.0 | 1 | 482.0 | 0.85 | 1 |
| P4KE400A | P4KE400CA | 342.00 | 380.0 | 420.0 | 1 | 548.0 | 0.75 | 1 |
| P4KE440A | P4KE440CA | 376.00 | 418.0 | 462.0 | 1 | 602.0 | 0.68 | 1 |
| P4KE480A | P4KE480CA | 408.00 | 456.0 | 504.0 | 1 | 658.0 | 0.61 | 1 |
| P4KE510A | P4KE510CA | 434.00 | 485.0 | 535.0 | 1 | 698.0 | 0.57 | 1 |
| P4KE530A | P4KE530CA | 450.00 | 503.5 | 556.5 | 1 | 725.0 | 0.55 | 1 |
| P4KE540A | P4KE540CA | 459.00 | 513.0 | 567.0 | 1 | 740.0 | 0.54 | 1 |
| P4KE550A | P4KE550CA | 467.00 | 522.5 | 577.5 | 1 | 760.0 | 0.52 | 1 |
| P4KE600A | P4KE600CA | 510.00 | 575.2 | 628.4 | 1 | 828.0 | 0.49 | 1 |

Ratings and Characteristic Curves ($T_A=25^\circ\text{C}$)

Figure 1. Peak Pulse Power Rating Curve

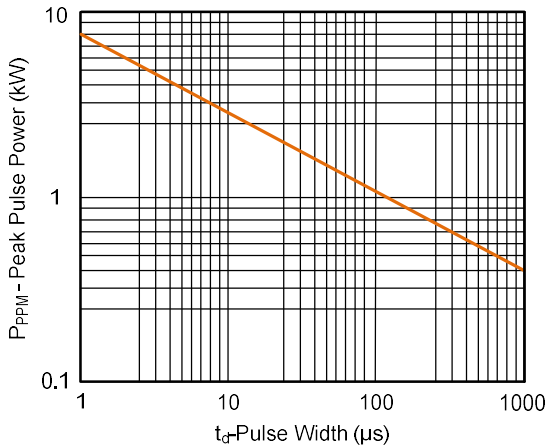

Figure 2. Pulse Derating Curve

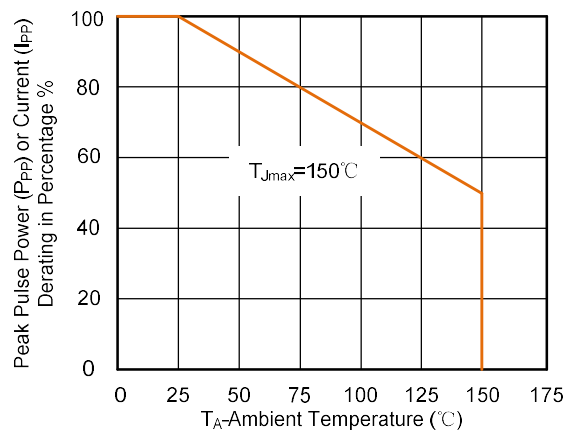

Figure 3. Pulse Waveform

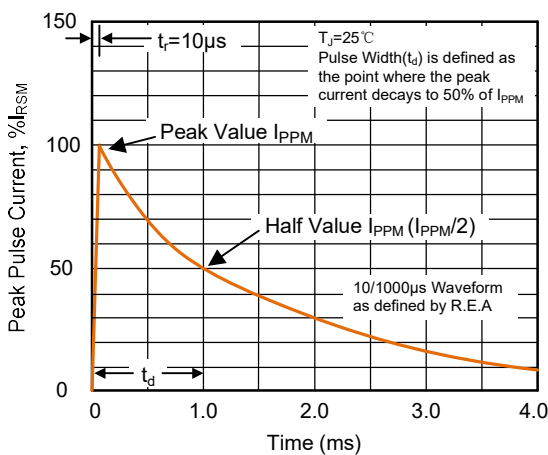

Figure 4. Typical Junction Capacitance

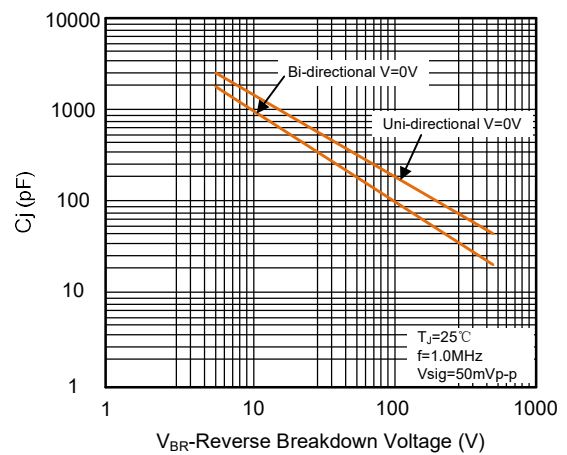

Figure 5. Steady State Power Dissipation Derating Curve

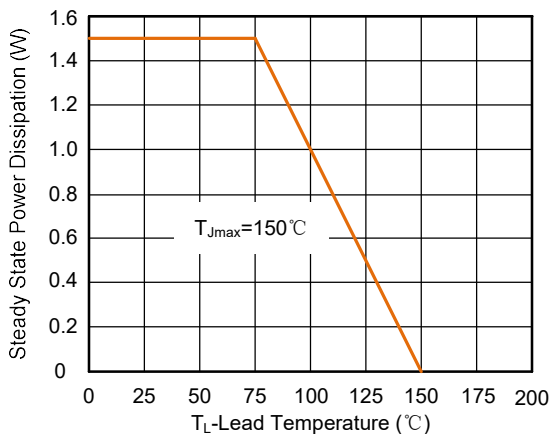
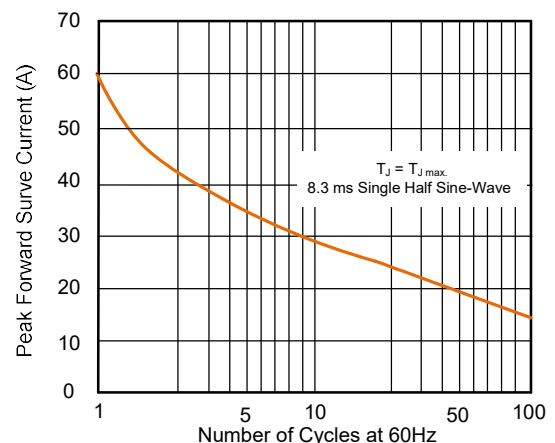
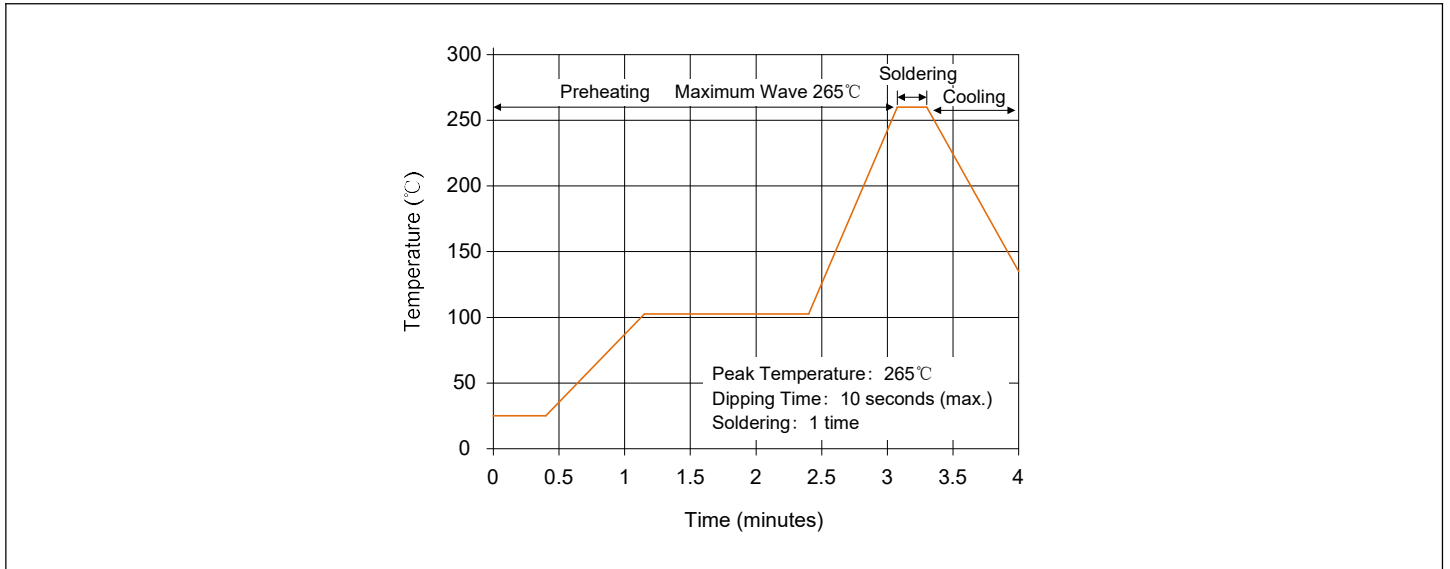

Figure 6. Maximum Non-Repetitive Forward Surge Current Uni-Directional Only



Wave Soldering



Part Number Code and Marking Code

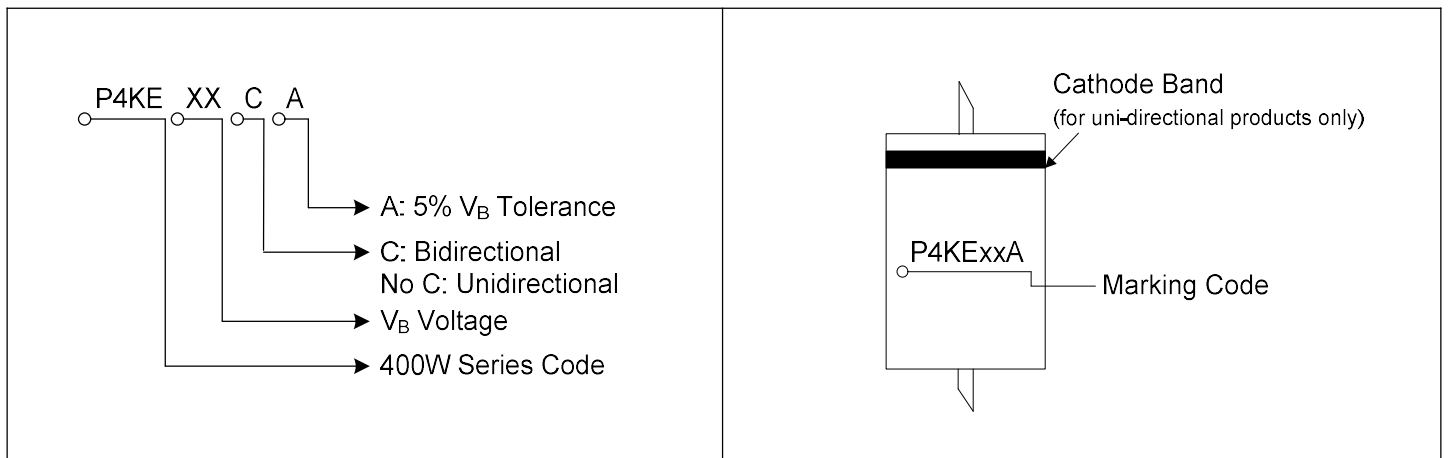

Dimensions (DO-204AL/DO-41)

The diagram shows the dimensions of the DO-204AL/DO-41 package. Dimensions A, B, C, and d are indicated. A is the length of the leads, B is the body length, C is the body diameter, and d is the lead diameter.

| Symbol | Millimeters | | Inches | |
|--------|-------------|------|--------|-------|
| | Min. | Max. | Min. | Max. |
| A | 25.40 | - | 1.000 | - |
| B | 4.10 | 5.20 | 0.160 | 0.205 |
| C | 2.00 | 2.70 | 0.080 | 0.107 |
| d | 0.71 | 0.86 | 0.028 | 0.034 |

Packaging Specification

Tape

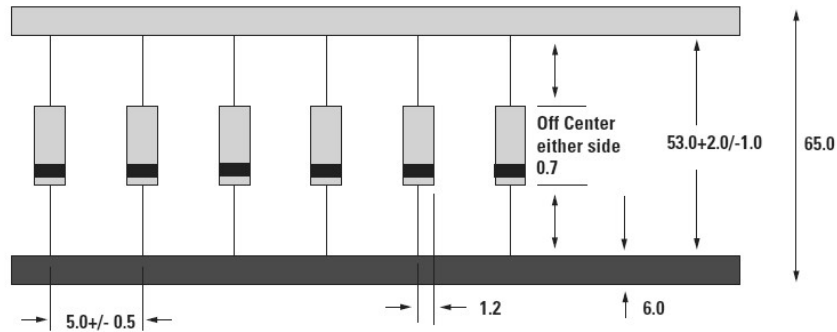

Box

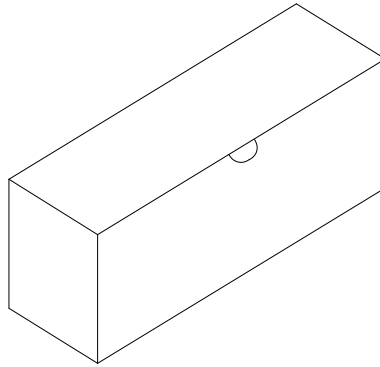

Quantity: 5000pcs/box

Reel

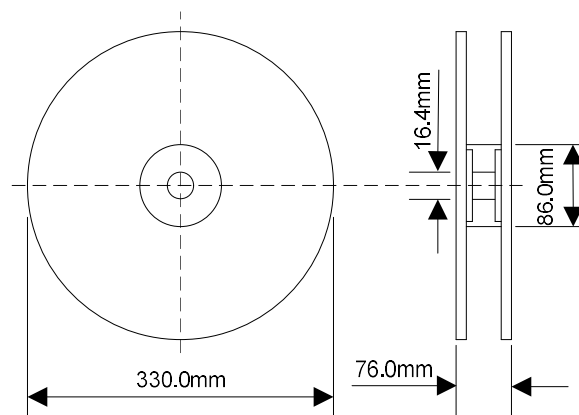

Quantity: 5000pcs/reel

X-ON Electronics

Largest Supplier of Electrical and Electronic Components

Click to view similar products for [ESD Suppressors / TVS Diodes](#) category:

Click to view products by [Liown](#) manufacturer:

Other Similar products are found below :

[60KS200C](#) [D18V0L1B2LP-7B](#) [D5V0F4U5P5-7](#) [NTE4902](#) [P4KE27CA](#) [P6KE11CA](#) [P6KE8.2A](#) [SA60CA](#) [SA64CA](#) [SMBJ12CATR](#)
[SMBJ33CATR](#) [SMBJ6.5A](#) [SMBJ8.0A](#) [ESD101-B1-02ELS E6327](#) [ESD112-B1-02EL E6327](#) [ESD7451N2T5G](#) [19180-510](#) [CPDT-5V0USP-](#)
[HF](#) [3.0SMCJ33CA-F](#) [3.0SMCJ36A-F](#) [HSPC16701B02TP](#) [JANTX1N6126A](#) [D3V3Q1B2DLP3-7](#) [D55V0M1B2WS-7](#) [SCM1293A-04SO](#)
[ESD200-B1-CSP0201 E6327](#) [SM12-7](#) [CEN955 W/DATA](#) [VESD12A1A-HD1-GS08](#) [CPDQC5V0-HF](#) [D1213A-01LP4-7B](#) [ESD101-B1-02EL](#)
[E6327](#) [AOZ8808DI-03](#) [5KP15A](#) [5KP48A](#) [5KP90A](#) [ESD3V3D7-TP](#) [15KPA36A-LF](#) [P4KE56CA](#) [P4KE68A](#) [P4KE91CATR](#) [P6KE120A](#)
[P6KE13CA](#) [P6KE43CA](#) [P6KE6.8CA](#) [P6KE8.2](#) [P6SMBJ20CA](#) [JANTX1N6072A](#) [SR2835ESKG](#) [SA90CA](#)