

LTE-C249

High Performance IR Emitter in
Reflective Bowl Type Package

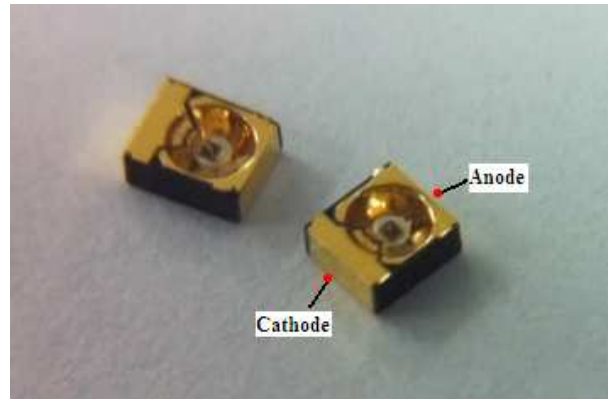

Description

The LTE-C249 series of flat-top IR emitters are packaged in a highly reflective gold plated bowls filled with high transmittivity silicone which offer high radiant intensity of 855nm IR light in a top view orientation.

This special package has an opaque base substrate that ensures zero emission from the sides and bottom, eliminating design problem relating to cross-talk.

Features

- Low profile SMT
- Size – 2.3 x 1.95 x 0.9mm (H)
- RoHS and Halogen Free compliant
- Peak wavelength – 855nm
- Narrow Viewing Angle - $\pm 15^\circ$
- Top View
- Highly reflective gold plated bowls (Bowl profile : patent pending)
- Zero emission from sides and bottom

Applications

- Proximity sensing
- Infrared communication links
- IR Remote controllers
- General IR illumination for cameras

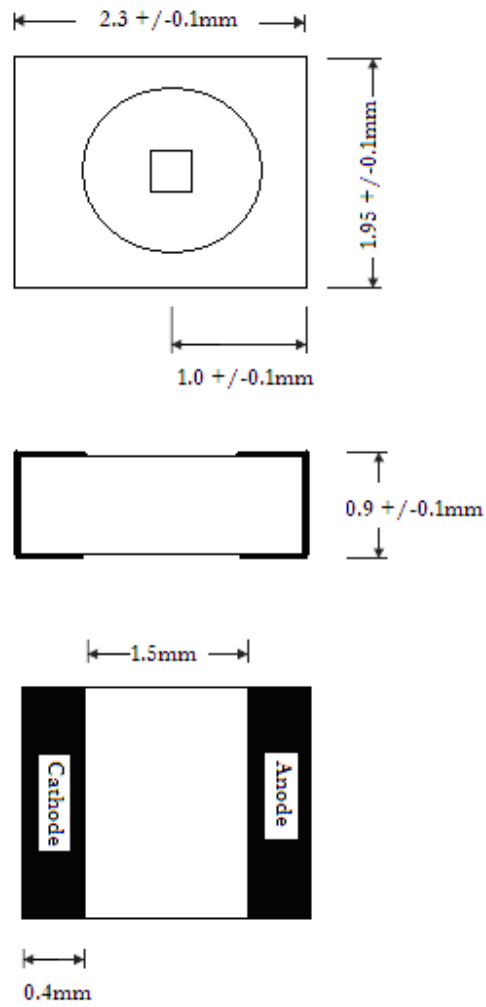
Package Dimensions



LITE-ON TECHNOLOGY CORPORATION.

Property of Lite-On Only

ABSOLUTE MAXIMUM RATINGS AT TA=25°C

PARAMETER	MAXIMUM RATING	UNIT
Power Dissipation	190	mW
Peak Forward Current (1% Duty Cycle , 4 μ s pulse)	800	mA
Continuous Forward Current	100	mA
Reverse Voltage	5	V
Operating Temperature Range	-40°C to + 85°C	
Storage Temperature Range	-55°C to + 100°C	
Infrared Soldering Condition	260°C For 10 Seconds	

Suggestion Profile:

Suggestion IR Reflow Profile For Pb Free Process

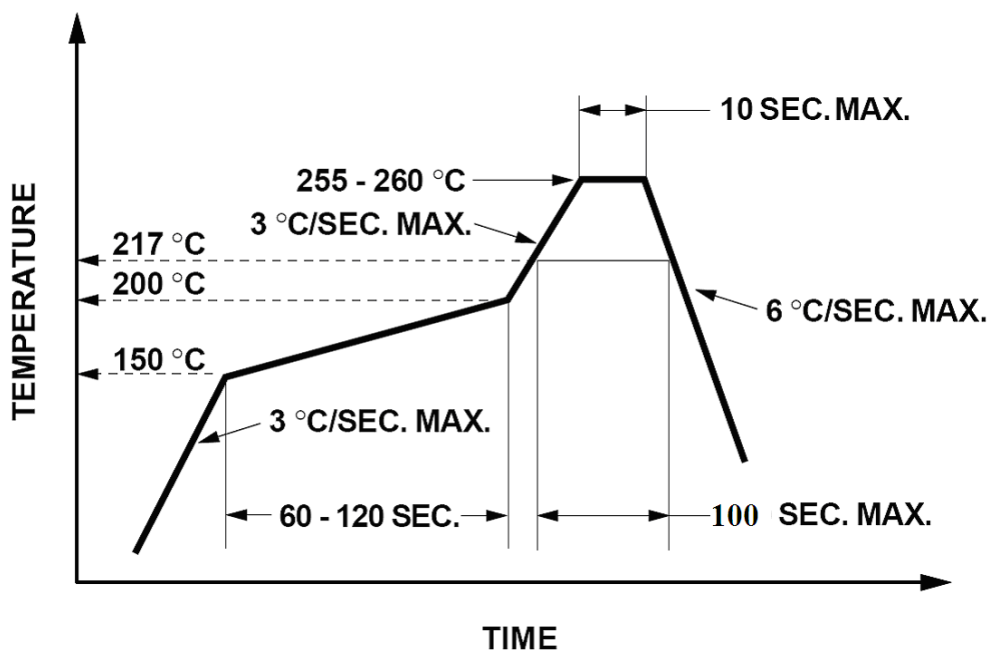



LITE-ON TECHNOLOGY CORPORATION.

Property of Lite-On Only

ELECTRICAL OPTICAL CHARACTERISTICS AT TA=25°C

PARAMETER	SYMBOL	MIN.	TYP.	MAX.	UNIT	TEST CONDITION
Radiant Intensity	I_E	14	35	56	mW/sr	$I_F = 70 \text{ mA}$
		20	50	80		$I_F = 100 \text{ mA}$
Peak Emission Wavelength	λ_{Peak}	-	855	-	nm	$I_F = 100\text{mA}$
Spectral Line Half-Width	$\Delta \lambda$	-	30	-	nm	$I_F = 100\text{mA}$
Forward Voltage	V_F	-	1.6	2.0	V	$I_F = 100\text{mA}$
Reverse Current	I_R	-	-	10	uA	$V_R = 5\text{V}$
Rise/Fall Time	T_r/T_f	-	13	-	ns	$I_F = 100\text{mA}$ Rload = 50ohm 10%~90%
Viewing Angle	$2\theta_{1/2}$	-	30	-	deg.	x-direction
			24			y-direction

TYPICAL ELECTRICAL / OPTICAL CHARACTERISTICS CURVES

(25°C Ambient Temperature Unless Otherwise Noted)

Figure 1. Spectral Distribution

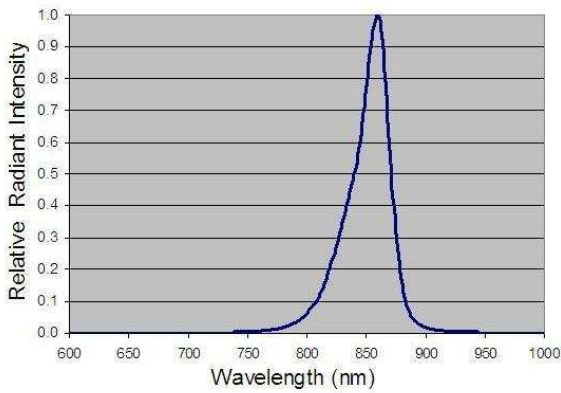

Figure 2. Temperature Derating

Max Tj=115degC, Tja=450K/W

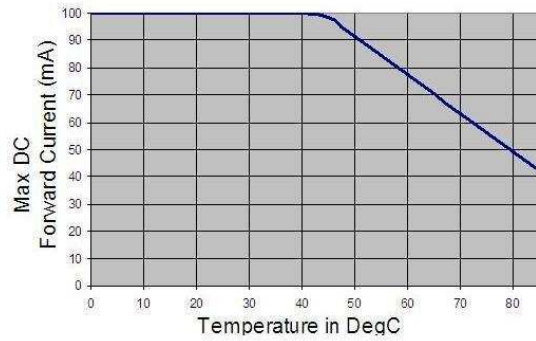

Figure 3. Forward Voltage vs Forward Current

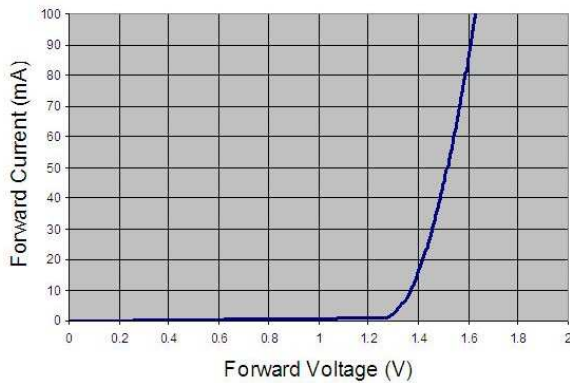
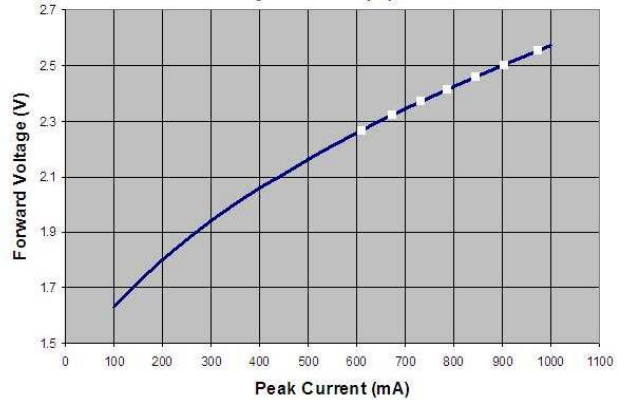

Figure 4. Forward Voltage (Vf) vs. Peak Current (Ifpk)

20us pulse 10% Duty cycle





LITE-ON TECHNOLOGY CORPORATION.

Property of Lite-On Only

TYPICAL ELECTRICAL / OPTICAL CHARACTERISTICS CURVES

(25°C Ambient Temperature Unless Otherwise Noted)

Figure 5. Intensity variation with Forward Current (I_{dc})

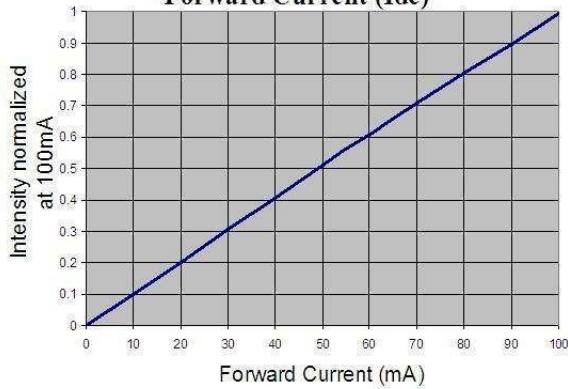

Figure 6. Intensity variation with Peak Current (I_{fpk})

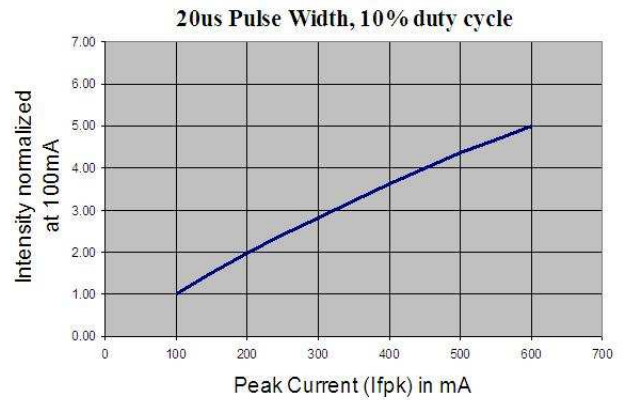

Figure 7. Forward Voltage (V_f) @ 100mA Vs Temperature

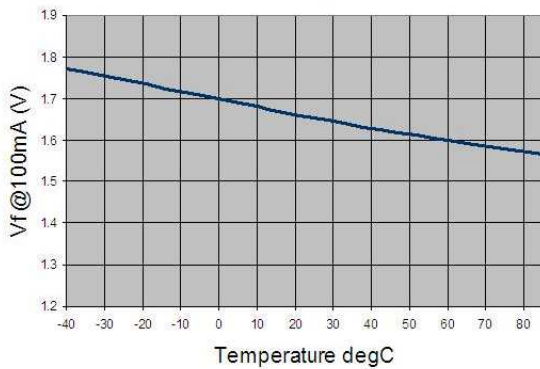
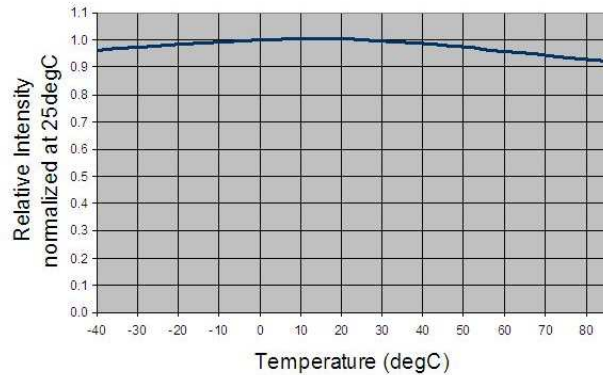

Figure 8. Relative Intensity Vs Temperature ($I_f=100mA$)



VIEWING ANGLE

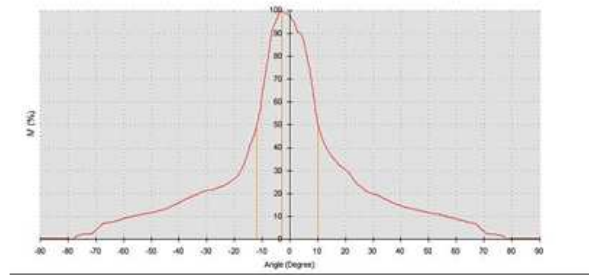
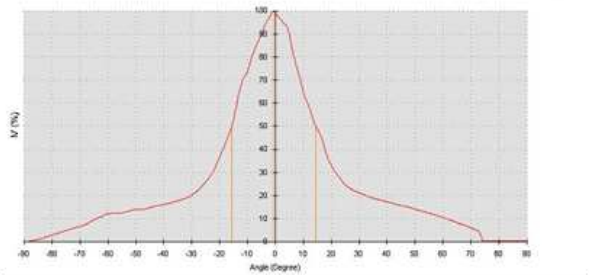
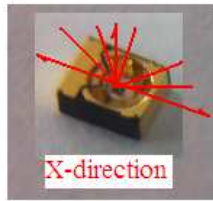
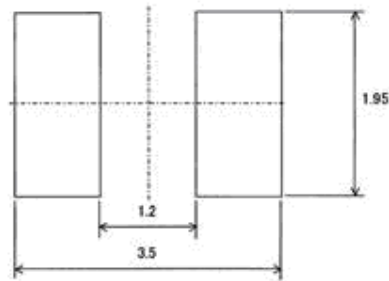
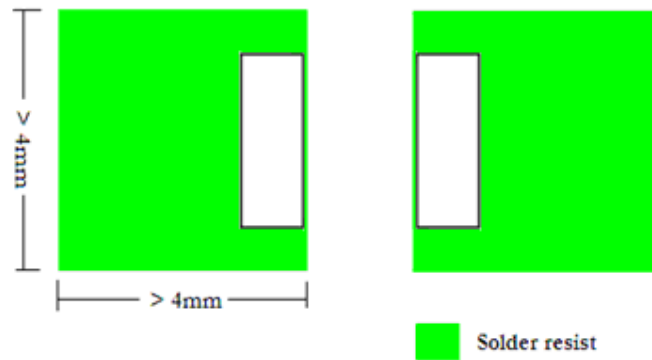

Figure 9. Viewing angle : 30° in the x-direction and 24° in the y-direction

Suggest Soldering Pad Dimensions

For better heat dissipation use bigger copper pad with suitable solder resist



Tape And Reel dimensions

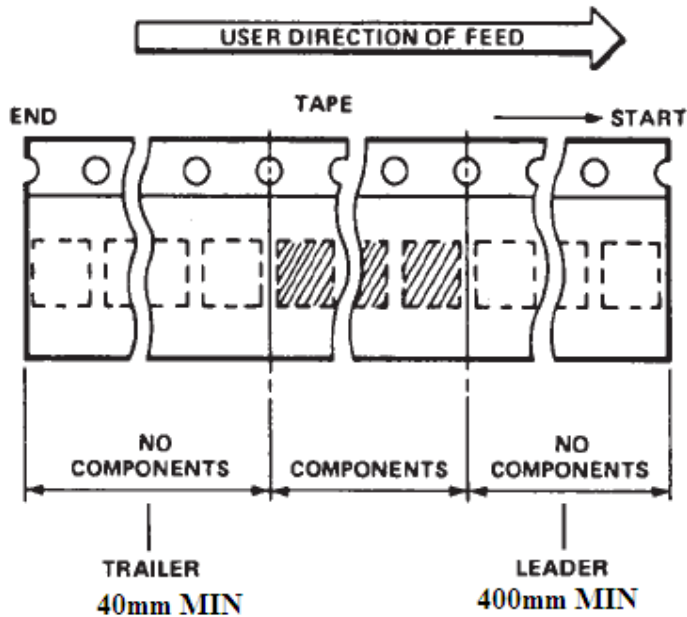
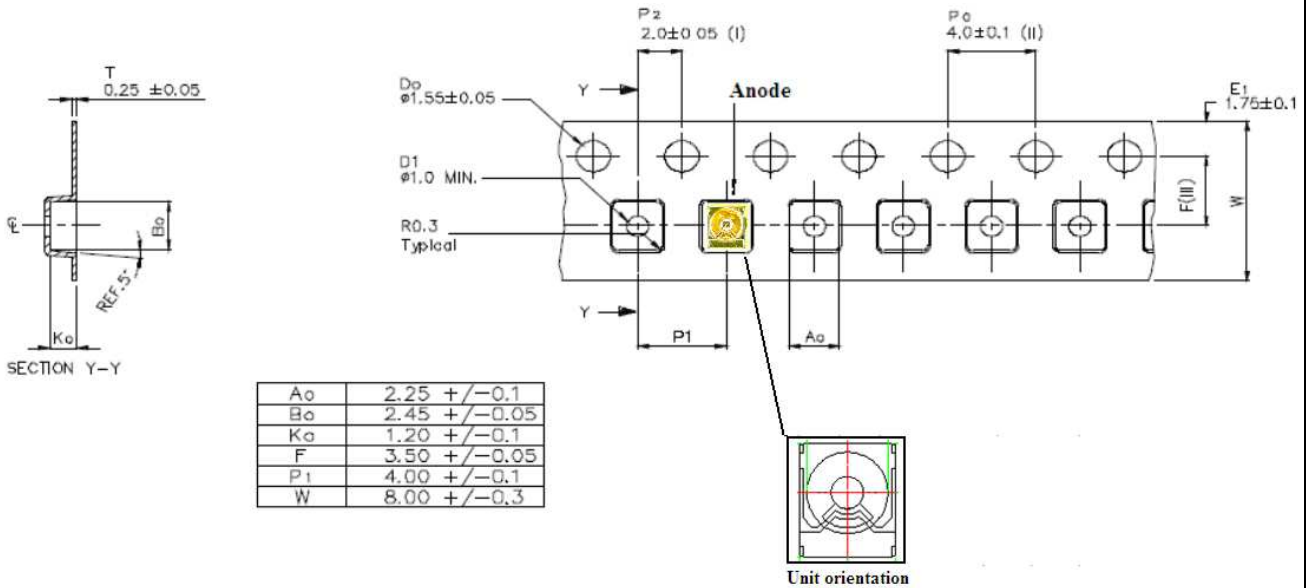

Notes:

1. All dimensions are in millimeters.
2. Empty component pockets sealed with top cover tape.
3. 7 inch reel-2000 pieces per reel.



CAUTIONS

1. Application

The device described here are intended to be used for ordinary electronic equipments (such as office equipments, communication equipments and household applications). Consult Liteon's Sales in advance for information on applications in which exceptional reliability is required, particularly when the failure or malfunction of the device may directly jeopardize life or health (such as in aviation, transportation, traffic control equipment, medical and life support systems and safety devices).

2. MOISTURE PROOF PACKAGING

All devices are shipped in moisture proof package.
Once opened, moisture absorption begins.

MSL LEVEL 2

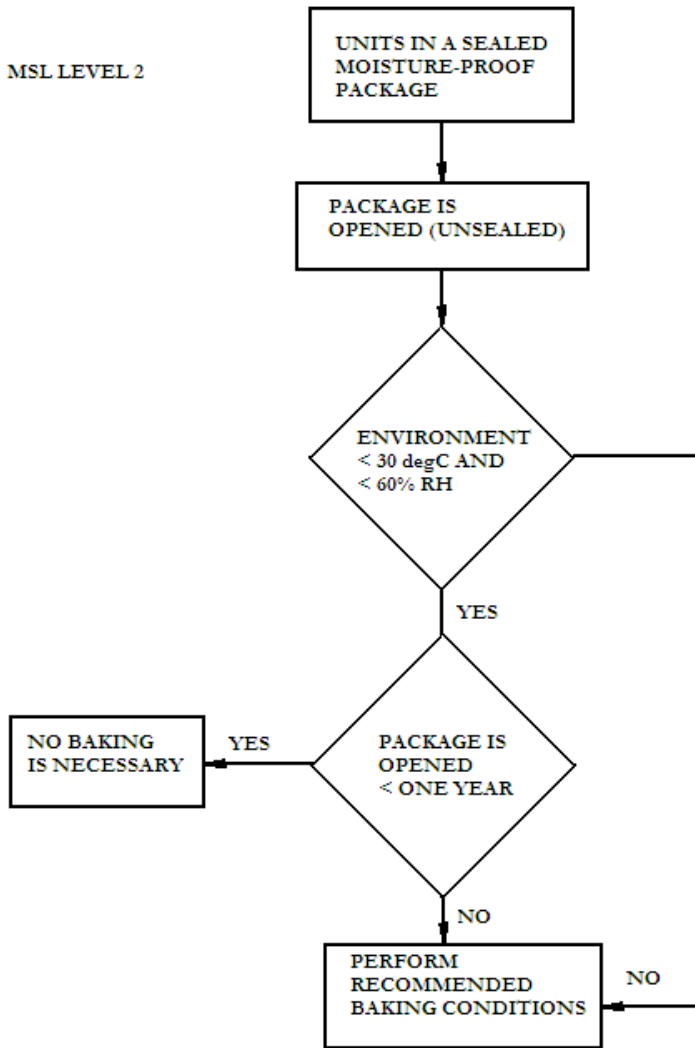

Baking conditions

If the parts are not stored in dry conditions, they must be baked before reflow to prevent damage to the parts.

Package	Temp	Time
In reels	60 degC	> 48 hrs
In bulk	100 degC	> 4 hrs

Baking should only be done once.

Time from Unsealing to Soldering

After removal from the bag, the parts should be soldered within a year if stored at the recommended storage conditions. If times longer than a year are needed, the parts must be stored in a dry box.

3. Cleaning

Do not use unspecified chemical liquid to clean the LED as it could harm the package. The LED die is protected with silicone compound that filled up the bowl cavity. Take special care not to apply too much mechanical stress to the silicone compound

4. Drive Method

An LED is a current-operated device. In order to ensure intensity uniformity on multiple Device connected in parallel in an application, it is recommended that a current limiting resistor be incorporated in the drive circuit, in series with each LED as shown in Circuit A below.



(A) Recommended circuit.

(B) The brightness of each LED might appear different due to the differences in the I-V characteristics of those Device.



LITE-ON TECHNOLOGY CORPORATION.

Property of Lite-On Only

This page is intentionally left blank.

X-ON Electronics

Largest Supplier of Electrical and Electronic Components

Click to view similar products for [Infrared Emitters](#) category:

Click to view products by [Lite-On](#) manufacturer:

Other Similar products are found below :

[LTE-309](#) [LTE-3279K](#) [LTE-4206C](#) [LTE-4208C](#) [EE-L105-X](#) [K3N](#) [QED123UL](#) [LTE-2871C](#) [LTE-2872U](#) [LTE-4238](#) [ASDL-4264-C22](#)
[TSHA6201](#) [TSHA6202](#) [HSDL-4400031](#) [EAIPL3528Z0](#) [OED-EL305F4C50-HT](#) [TSUS6202](#) [OP216-004](#) [VSMY98145DS](#) [VSMY99445DS](#)
[HL-PST-1608IR1C-L4](#) [IN-S126ETIR](#) [IN-S126DSHIR](#) [IN-S126ETHIR](#) [IN-P32ZTHIR](#) [IN-S126BTHIR](#) [IN-S63DTHIR](#) [IN-S85BTHIR](#) [IN-S63FTHIR](#) [E6C0805IRAC1UDA940nm](#) [HIR204C/H0](#) [HIR204/H0](#) [HIR323C](#) [LTE-209](#) [TSML1030](#) [IR12-21C/TR8](#) [IR17-21C/TR8](#) [IR383](#)
[IR91-21C/TR10](#) [WP7113F3BT](#) [SFH 4948](#) [SFH 4949](#) [LTE-4208](#) [OP235W](#) [OP297FAB](#) [TSHA5201](#) [TSHA5500](#) [TSTS7500](#) [TSUS5201](#)
[TSUS5401](#)