

OPTICAL SENSOR LTR-X150P

Description

The LTR-X150P is a standalone proximity sensor (PS), with built-in emitter in a single miniature chipled lead-free surface mount package.

Besides, with built-in proximity sensor, this sensor offers the feature to detect object at a user configurable distance.

The sensor has a PS programmable interrupt with hysteresis to response to events and that removes the need to poll the sensor for a reading which improves system efficiency. This CMOS design and factory-set one time trimming capability ensure minimal sensor-to-sensor variations for ease of manufacturability to the end customers.

Application

- Control brightness of display panel
- Object detection in mobile, computing, and consumer devices.

Features

- I²C interface (Standard mode @100kHz or Fast mode @400kHz)
- ultra-small ChipLED package
- Very low power consumption with sleep mode capability
- Operating voltage ranges: 1.7V to 3.6V
- Operating temperature ranges: -40 to +85 °C
- Built-in temperature compensation circuit
- Programmable interrupt function for PS with upper and lower thresholds
- RoHS and Halogen free compliant

PS Features

- Built-in LED driver
- High ambient light suppression
- 16-bit effective resolution
- Cancellation of crosstalk
- Programmable LED drive setting

Ordering Information

Part Number	Packaging Type	Package	Quantity
LTR-X150P	Tape and Reel	8-pin chipled package	3,000pcs

OPTICAL SENSOR LTR-X150P

1. Outline Dimensions and Pins Configuration

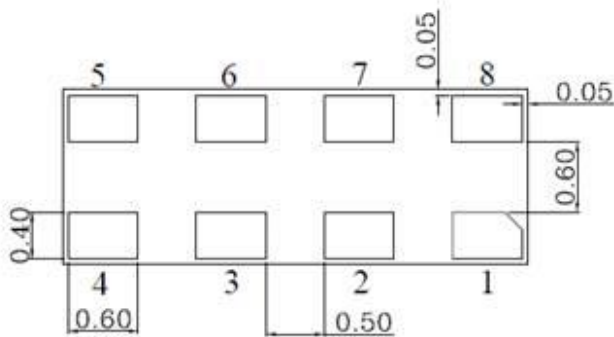
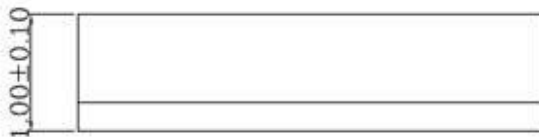
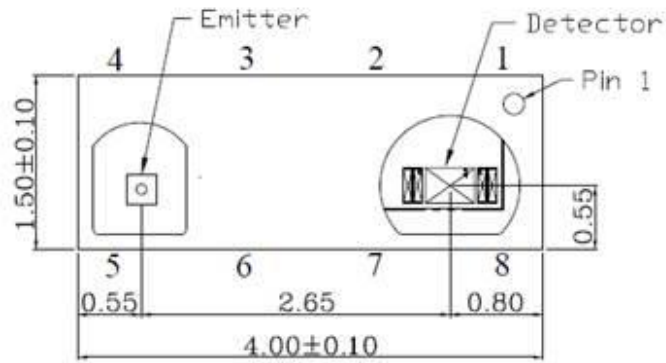

Pin-Out Assignment:

1. VDD	5. LDR
2. SCL	6. NC
3. GND	7. INT
4. LEDA	8. SDA

1. All dimensions in mm
2. Tolerances is +/-0.2 unless specify

Note: All dimension in millimeter

OPTICAL SENSOR LTR-X150P

2. Functional Block Diagram

The LTR-X150P contains a photodiodes (1 for proximity diode) for photocurrent measurement. The photodiode currents are converted to digital values by ADCs. The sensor also included a LED driver, as well as some peripheral circuits such as an internal oscillator, a current course, voltage reference, and internal fuses to store trimming information.

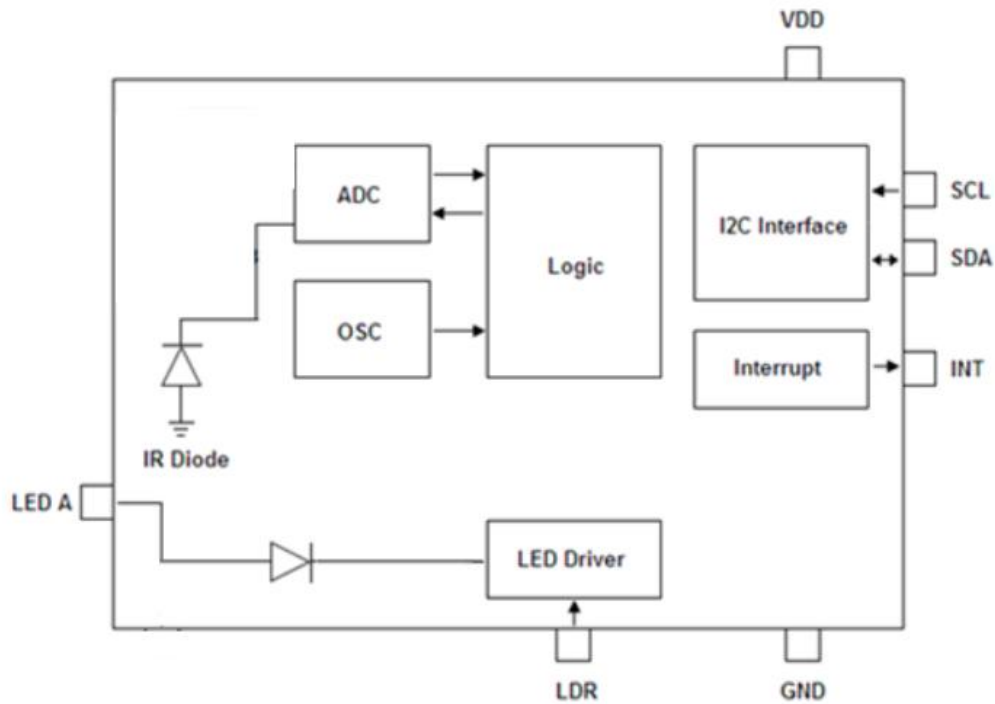

OPTICAL SENSOR LTR-X150P

3. Application Circuit

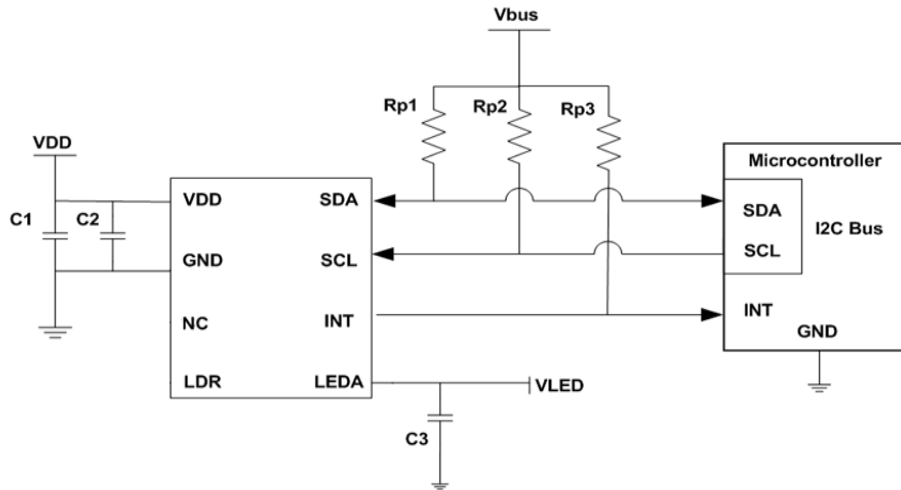

Note: It is a requirement to separate the VDD and VLED

In the powering off sequence, the VLED should be powered off first followed by the VDD.

I/O Pins Configuration Table

Pin	I/O Type	Symbol	Description
1		VDD	Supply Voltage
2	I	SCL	I ² C serial clock
3		GND	GND
4		LEDA	LED Anode.
5	O	LDR	LED driver. To connect to LED Cathode.
6		NC	No Connection on this pin
7	O	INT	Interrupt pin
8	I/O	SDA	I ² C serial data

Recommended Application Circuit Components

Component	Recommended Value
Rp1, Rp2, Rp3 [1]	1 kΩ to 10 kΩ
C1, C3	1μF ±20%, X7R / X5R Ceramic
C2	0.1μF

[1] Selection of pull-up resistors value is dependent on bus capacitance values. For more details, please refer to I²C Specifications: http://www.nxp.com/documents/user_manual/UM10204.pdf

OPTICAL SENSOR LTR-X150P

4. Ratings and Specifications

Absolute Maximum Ratings at Ta = 25°C

Parameter	Symbol	Min.	Max	Unit
Supply Voltage	VDD		3.6	V
Digital Voltage Range	SCL, SDA, INT	-0.5	3.6	V
LED Voltage Range	LED	-0.5	4.6	V
LDR Voltage Range	LDR	-0.5	3.6	V
Storage Temperature	T _{stg}	-40	100	°C
Electrostatic Discharge Protection (Human Body Model JESD22-A114)	V _{HBM}		2000	V

Note: Exceeding these ratings could cause damage to the sensor. All voltages are with respect to ground. Currents are positive into, negative out of the specified terminal.

Recommended Operating Conditions

Description	Symbol	Min.	Typ.	Max.	Unit
Supply Voltage	VDD	1.7		3.6	V
LED Supply Voltage	V _{LED}	2.8		4	V
Interface signal input high	V _{I2Chigh}	1.5		VDD	V
Interface signal input low	V _{I2Clow}	0		0.4	V
Operating Temperature	T _{ope}	-30		85	°C

Electrical & Optical Specifications

All specifications are at VDD = 1.8V, T_{ope} = 25°C, unless otherwise noted.

Parameter	Min.	Typ.	Max.	Unit	Condition
Supply Current		57		uA	MRR 100ms with 8 pulses, 100%duty, 32 us pulse width
Standby Current		1		uA	Shutdown Mode
Wakeup Time from Standby		0.25		ms	From Standby to Active mode where measurement can start

OPTICAL SENSOR LTR-X150P

Characteristics Proximity Sensor

Parameter	Min.	Typ.	Max.	Unit	Condition
PS Resolution			16	Bit	
Sensitivity Range		940		nm	
Detection Distance		20		cm	Pulse Width 32us, 16 pulses, LED Current 104mA
LED Pulse Current			186	mA	Configurable
LED Pulse width			64	us	Configurable for 8,16,32, 64 us
Number of LED Pulses	1		256	Pulses	
Ambient light suppression **			10	klux	Direct sunlight

** Above TBD Klux, internal fail-safe feature will force PS count to eight to prevent false trigger.

Typical Device Parameter

(VDD = 1.8V, Ta=25°C, Default power-up settings, unless otherwise noted)



Figure 4.1: PS performance across distance VDD 1.8V, 104mA, 16pulses, with others in default settings.

OPTICAL SENSOR LTR-X150P

Electrical Characteristics

All specifications are at VBus = 1.7V, T_{ope} = 25°C, unless otherwise noted.

Parameter	Symbol	Standard mode		Fast mode		Unit
		Min.	Max.	Min.	Max.	
SCL clock frequency	f_{SCL}	100		400		kHz
Bus free time between a STOP and START condition	t_{BUF}	4.7	-	1.3	-	us
Hold time (repeated) START condition. After this period, the first clock pulse is generated	$t_{HD;STA}$	4.0	-	0.6	-	us
LOW period of the SCL clock	t_{LOW}	4.7	-	1.3	-	us
HIGH period of the SCL clock	t_{HIGH}	4.0	-	0.6	-	us
Set-up time for a repeated START condition	$t_{SU;STA}$	4.7	-	0.6	-	us
Set-up time for STOP condition	$t_{SU;STO}$	4.0	-	0.6	-	us
Rise time of both SDA and SCL signals	t_r	-	1000	-	300	ns
Fall time of both SDA and SCL signals	t_f	-	300	-	300	ns
Data hold time	$t_{HD;DAT}$	0	-	0	-	us
Data setup time	$t_{SU;DAT}$	250	-	100	-	ns

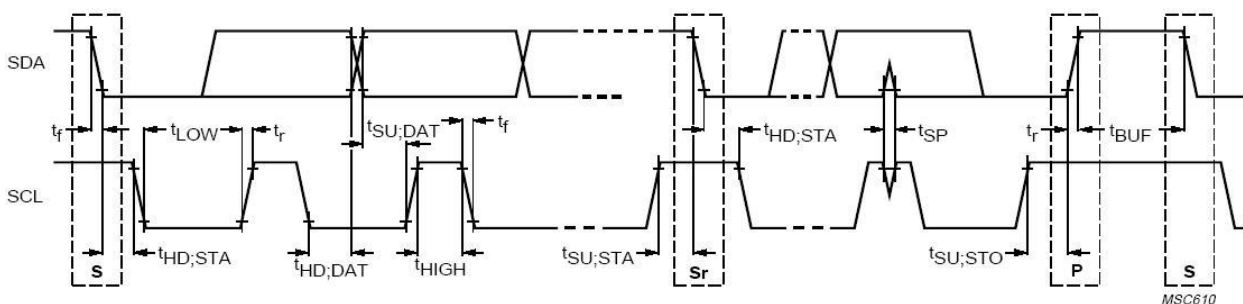

MSC610

Definition of timing for I²C bus

5. Principles of Operation

I²C Protocols

- I²C Write Protocol (type 1):

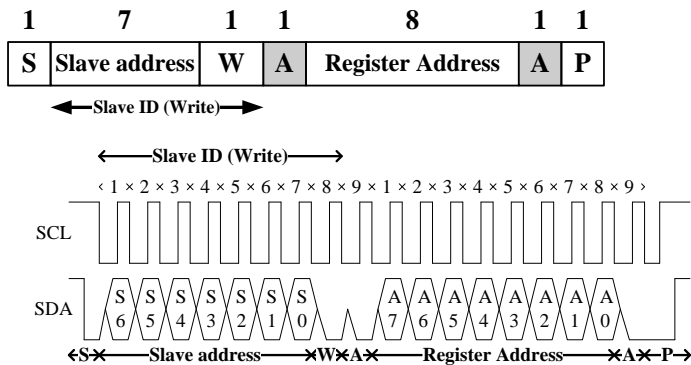

- I²C Write Protocol (type 2):

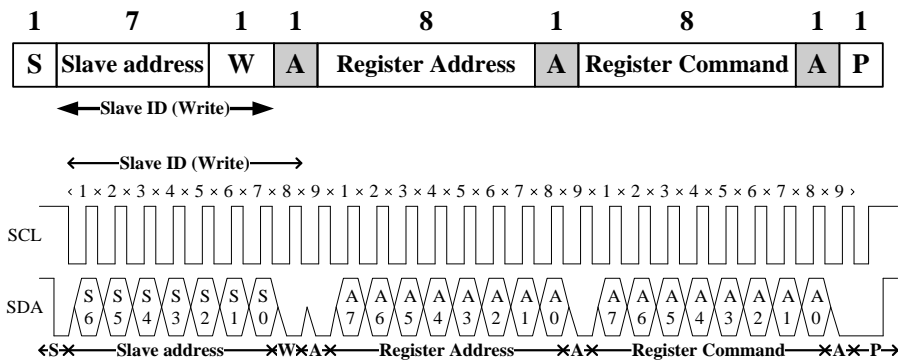

- I²C Read Protocol:

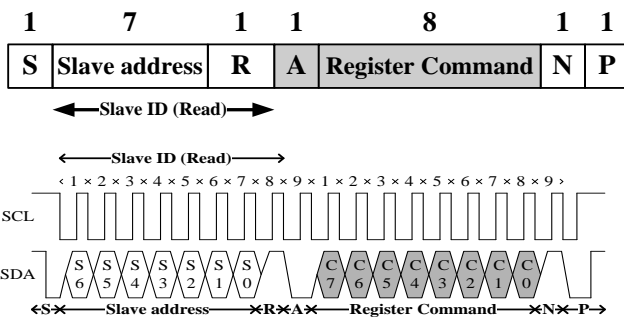

- I²C Read (Combined format) Protocol:

OPTICAL SENSOR LTR-X150P

6. Register Set

Address	R / W	Register Name	Description	Reset Value
0x81	RW	PS_CONTR	PS operation mode control/SW Reset	0x00
0x82	RW	PS_LED_DUTY_PW	PS LED pulse duty cycle and pulse width setting	0x0E
0x83	RW	PS_LED_CURRENT	PS LED current	0x0F
0x84	RW	PS_N_PULSES	PS number of pulses	0x00
0x93	RW	PS_GAIN	PS Gain setting	0x10
0x94	RW	PS_MEAS_RATE	PS average PS measurement rate	0xA9
0x95	RW	PS_LED_DUTY_PW_INV	Invert of 0x82	0x01
0x96	RW	PS_LED_CURRENT_INV	Invert of 0x83	0x10
0x97	RW	PS_N_PULSES_INV	Invert of 0x84	0xFF
0x99	R	PS_STATUS	PS Status	0x00
0x9A	R	PS_DATA_LSB	PS measurement data, LSB	0x00
0x9B	R	PS_DATA_MSB	PS measurement data, MSB	0x00
0xA7	RW	INTERRUPT	Interrupt settings	0x40
0xA8	RW	INTERRUPT_PERSIST	PS interrupt persist setting	0x00
0xA9	RW	PS_THRES_HIGH_LSB	PS interrupt upper threshold, LSB	0xFF
0xAA	RW	PS_THRES_HIGH_MSB	PS interrupt upper threshold, MSB	0xFF
0xAB	RW	PS_THRES_LOW_LSB	PS interrupt lower threshold, LSB	0x00
0xAC	RW	PS_THRES_LOW_MSB	PS interrupt lower threshold, MSB	0x00
0xAD	RW	PS_XTALK_LSB	Xtalk correction on PS, LSB	0x00
0xAE	RW	PS_XTALK_MSB	Xtalk correction on PS, MSB	0x00
0xB3	R	PART_ID	Part Number ID and revision IDs	0x9C
0xB4	R	MANUFAC_ID	Manufacturer ID	0x05
0xB6	RW	PS_CONFIG_1	PS configuration register 1	0xF5
0xDB	RW	PS_CONFIG_2	PS configuration register 2	0x14
0xE3	RW	PS_CONFIG_3	PS configuration register 3	0x67
0xF9	RW	PS_CONFIG_4	PS configuration register 4	0x8F
0xD8	RW	PS_DIODE_SELECT	PS diode select	0x0F

OPTICAL SENSOR LTR-X150P

PS_CONTR Register (0x81) (Read/Write)

The PS_CONTR register controls the PS operation modes and software reset for sensor. The PS sensor can be set to either standby mode or active mode. At either of these modes, the I2C circuitry is always active. The default mode after power up is standby mode. During standby mode, there is no PS measurement performed but I2C communication is allowed to enable read/write to all the registers.

0x81	PS_CONTR (default = 0x00)							
	Bit 7	Bit 6	Bit 5	Bit 4	Bit 3	Bit 2	Bit 1	Bit 0
	Smart persist Enable	Reserved		PS_16 BITS_EN	PS_OS	FTN/NTF Enable	PS Mode	SW Reset

Field	Bits	Default	Description	
Smart persist EN	7	0	Enable fast PS threshold persistence check which can be done within 1 measurement time setting.	
			0	Disable (default)
			1	Enable
Reserved	6:5	00	Must write as 00	
PS_16BITS_EN	4	0	0	Output 11 bits with data cap at 11 bits only (default)
			1	Output 16 bits
PS_OS	3	0	PS offset cancellation. When enabled, PS DATA will be subtracted with PS OFFSET register data, 0xAD,0xAE	
			0	Disabled (default)
			1	Enabled
FTN/FTN_EN	2	0	0	Disable FTN/NTF Status reporting (default)
			1	Enable FTN/NTF Status reporting
PSMODE	1	0	0	Stand-by mode (default)
			1	Active mode
SW_RST	0	0	Reset registers to default values, with sensor into standby mode.	
			0	No action (default)
			1	Reset Registers to default values (including calibration values)

OPTICAL SENSOR LTR-X150P

PS_LED_DUTY_PW Register (0x82) (Read/Write)

PS LED duty cycle and pulse width settings. **Must be written in tandem with inverted register 0x95.**

0x82	PS_LED_DUTY_PW (default = 0x0E)							
	Bit 7	Bit 6	Bit 5	Bit 4	Bit 3	Bit 2	Bit 1	Bit 0
	Reserved				PLED Pulse Duty		PLED Pulse Width	

Field	Bits	Default	Description	
Reserved	7:4	0000	Must write 0000	
PLED Pulse Duty	3:2	11	00	25%
			01	50%
			10	75%
			11	100% (default)
PLED Pulse Width	1:0	10	PS LED ON-time pulse width.	
			00	8us
			01	16us
			10	32us (default)
			11	64us

PS_LED_CURRENT Register (0x83) (Read/Write)

PS LED Current settings. **Must be written in tandem with inverted register 0x96.**

0x83	PS_LED_Current (default = 0x0F)							
	Bit 7	Bit 6	Bit 5	Bit 4	Bit 3	Bit 2	Bit 1	Bit 0
	Reserved				LED Current			

Field	Bits	Default	Description
-------	------	---------	-------------

**OPTICAL SENSOR
LTR-X150P**

Reserved	7:5	000	Must write 000	
LED Current	4:0	01111	LED current selection	
			00000	0 mA
			00001	7 mA
			00010	13 mA
			00011	20 mA
			00100	27 mA
			00101	33 mA
			00110	40 mA
			00111	47 mA
			01000	53 mA
			01001	60 mA
			01010	67 mA
			01011	73 mA
			01100	80 mA
			01101	87 mA
			01110	93 mA
			01111	100 mA (default)
			10000	107 mA
			10001	113 mA
			10010	120 mA
			10011	127 mA
			10100	133 mA
			10101	140 mA
			10110	147 mA
			10111	153 mA
			11000	160 mA
			11001	167 mA
			11010	173 mA
11011	180 mA			
111xx	186 mA			

OPTICAL SENSOR LTR-X150P

PS_N_PULSES Register (0x84) (Read/Write)

This register controls number of PS LED pulses. **Must be written in tandem with inverted register 0x97.**

0x84	PS_N_PULSES (default = 0x00)							
	Bit 7	Bit 6	Bit 5	Bit 4	Bit 3	Bit 2	Bit 1	Bit 0
	<i>PS Number of LED Pulses</i>							

Field	Bits	Default	Description	
PS Number of LED Pulses	7:0	0x00	00000000 to 11111111	Specifies PS LED number of pulses. If PS number of pulse set to 0, the pulse count is 1. Maximum is 256 pulses

PS_GAIN Register (0x93) (Read/Write)

0x93	PS_GAIN (default = 0x10)							
	Bit 7	Bit 6	Bit 5	Bit 4	Bit 3	Bit 2	Bit 1	Bit 0
	<i>Reserved</i>						<i>PS Gain</i>	

Field	Bits	Default	Description	
Reserved	7:2	000100	Must write 000100	
PS Gain	1:0	00	00	1x (default)
			01	2x
			10	4x
			11	8x

OPTICAL SENSOR LTR-X150P

PS_MEAS_RATE Register (0x94) (Read/Write)

The PS_MEAS_RATE register controls the timing of the periodic measurements of the PS in active mode.

Measurement Repeat Rate is the interval between DATA registers update.

0x94	PS_MEAS_RATE (default = 0xA9)							
	Bit 7	Bit 6	Bit 5	Bit 4	Bit 3	Bit 2	Bit 1	Bit 0
	Reserved	Average Accumulate EN	PS Average/ Accumulation		PS Measurement Time			

Field	Bits	Default	Description	
Reserved	7	1	Must write 1	
Average Accumulate EN	6	0	0	Output average data (default)
			1	Output accumulated data
PS Average /Accumulation	5:4	10	Number of PS data for averaging	
			00	No average
			01	2x average
			10	4x average (default)
PS Measurement Time	3:0	1001	0011	3.125ms
			0100	6.25ms
			0101	12.5ms
			0110	25ms
			0111	50ms
			1000	75ms
			1001	100ms (default)
			1010	125ms
1011	150ms			

OPTICAL SENSOR LTR-X150P

			1100	175ms
			1101	200ms

PS_LED_DUTY_PW_INV Register (0x95) (Read/Write)

Inverted PS_LED_DUTY_PW settings. **Must be written in tandem with register 0x82.**

0x95	PS_LED_DUTY_PW_INV (default = 0x01)							
	Bit 7	Bit 6	Bit 5	Bit 4	Bit 3	Bit 2	Bit 1	Bit 0
	Reserved				PLED Pulse Duty Inverse		PLED Pulse Width Inverse	

Field	Bits	Default	Description	
Reserved	7:4	0000	Must write 0000	
PLED Pulse Duty Inverse	3:2	00	PS LED pulse duty cycle.	
			11	25%
			10	50%
			01	75%
PLED Pulse Width Inverse	1:0	01	PS LED ON-time pulse width	
			11	8us
			10	16us
			01	32us (default)
			00	64us

PS_LED_CURRENT_INV Register (0x96) (Read/Write)

Inverted PS_LED_Current settings. **Must be written in tandem with inverted register 0x83.**

0x96	PS_LED_CURRENT_INV (default = 0x10)							
	Bit 7	Bit 6	Bit 5	Bit 4	Bit 3	Bit 2	Bit 1	Bit 0
	Reserved				LED Current			

**OPTICAL SENSOR
LTR-X150P**

Field	Bits	Default	Description
Reserved	7:5	000	Must write 000
LED Current	4:0	10000	LED current selection
			11111 0 mA
			11110 7 mA
			11101 13 mA
			11100 20 mA
			11011 27 mA
			11010 33 mA
			11001 40 mA
			11000 47 mA
			10111 53 mA
			10110 60 mA
			10101 67 mA
			10100 73 mA
			10011 80 mA
			10010 87 mA
			10001 93 mA
			10000 100 mA (default)
			01111 107 mA
			01110 113 mA
			01101 120 mA
			01100 127 mA
01011 133 mA			
01010 140 mA			
01001 147 mA			
01000 153 mA			
00111 160 mA			

OPTICAL SENSOR LTR-X150P

			00110	167 mA
			00101	173 mA
			00100	180 mA
			000xx	186 mA

PS_N_PULSES_INV Register (0x97) (Read/Write)

The PS_N_Pulses_INV register activates the PS number of pulse function written in PS_N_Pulses Register (0x84).

The value written in PS_LED_INV is inverse value of PS_N_Pulses 0x84.

0x97	PS_N_PULSE_INV (default = 0xFF)							
	Bit 7	Bit 6	Bit 5	Bit 4	Bit 3	Bit 2	Bit 1	Bit 0
	<i>PS Number of LED Pulses</i>							

Field	Bits	Default	Description	
PS Number of LED Pulses	7:0	0xFF	11111111 to 00000000	Specifies PS LED number of pulses. If PS number of pulse set to 11111111, the pulse count will be 1

PS_STATUS Register (0x99) (Read Only)

0x99	PS_STATUS (default = 0x00)							
	Bit 7	Bit 6	Bit 5	Bit 4	Bit 3	Bit 2	Bit 1	Bit 0
	<i>Reserved</i>		<i>FTN</i>	<i>NTF</i>	<i>PS LED Setting Invalid Flag</i>	<i>PS_INT Greater RATE flag</i>	<i>PS_INT status</i>	<i>PS data status</i>

Field	Bits	Default	Description	
Reserved	7:6	00	-	
FTN	5	0	0	No far to near object detected (default)

OPTICAL SENSOR LTR-X150P

			1	Far to near object detected
NTF	4	0	0	No near to far object detected (default)
			1	Near to far object detected
PS LED Setting Invalid Flag	3	0	PS LED settings are invalid if the settings in registers 0x95, 0x96 and 0x97 are not inverse of registers 0x82, 0x83 and 0x84.	
			0	Valid (default)
			1	Invalid
PS_INT Greater RATE Flag	2	0	This flag to check PS Integration time greater or less than measurement rate	
			0	Less than (default)
			1	Greater than
PS Interrupt Status	1	0	0	Interrupt signal INACTIVE (default)
			1	Interrupt signal ACTIVE
PS Data Status	0	0	0	OLD data (data already read) (default)
			1	NEW data (first time data is read)

PS_DATA Register (0x9A – 0x9B) (Read Only)

PS measurement results are stored in PS_DATA registers. It is necessary to do a block read from registers 0x99 to 0x9C to ensure the data integrity.

Field	Register	Default	Description
PS Data LSB	0x9A	00000000	PS measurement data LSB
PS Data MSB	0x9B	00000000	PS measurement data MSB

AMBIENT_IR_SATURATION Register (0x9C) (Read Only)

0x9C	AMBIENT_IR_SATURATION (default = 0x00)							
	Bit 7	Bit 6	Bit 5	Bit 4	Bit 3	Bit 2	Bit 1	Bit 0
	Reserved	Ambient IR Saturation Flag	Reserved					

OPTICAL SENSOR LTR-X150P

Field	Bits	Default	Description
Reserved	7	0	-
<i>Ambient IR Saturation Flag</i>	6	0	0 Ambient IR not saturate (default)
			1 Ambient IR saturate
Reserved	5:0	000000	-

INTERRUPT Register (0xA7) (Read/Write)

INTERRUPT register controls the operation of the interrupt pin and functions.

0xA7	INT (default = 0x40)								
	Bit 7	Bit 6	Bit 5	Bit 4	Bit 3	Bit 2	Bit 1	Bit 0	
	<i>Reserved</i>				<i>Interrupt Polarity</i>	<i>Interrupt Mode</i>		<i>Reserved</i>	

Field	Bits	Default	Description
Reserved	7:4	0100	Must write 0100
Interrupt Polarity	3	0	0 INT pin is active when it is a logic 0 (default)
			1 INT pin is active when it is a logic 1
Interrupt Mode	2:1	00	00 Interrupt pin is INACTIVE / high impedance state (default)
			01 PS measurement can trigger interrupt
			-- --
			-- --
Reserved	0	0	Must write 0

OPTICAL SENSOR LTR-X150P

INTERRUPT_PERSIST Register (0xA8) (Read/Write)

Interrupt persist register sets the N number of times the measurement is out of the threshold range settings before asserting the INTERRUPT pin.

0xA8	INT (default = 0x00)							
	Bit 7	Bit 6	Bit 5	Bit 4	Bit 3	Bit 2	Bit 1	Bit 0
	PS_PERSIST				Reserved			

Field	Bits	Default	Description	
PS_PERSIST	7:4	0000	0	Every PS value out of threshold range (default)
			1	1 consecutive PS values out of threshold range
		
			1111	15 consecutive PS values out of threshold range
Reserved	3:0	0000	--	--

PS_THRESHOLD Register (0xA9 – 0xAC) (Read/Write)

PS_THRESHOLD_HIGH register is used to set the upper limit of the absolute interrupt threshold value. Interrupt functions compare the value in the PS_THRESHOLD_HIGH registers to measured data value in PS_DATA registers. The data format for PS_THRESHOLD_HIGH must be the same as that of PS_DATA registers.

Field	Register	Default	Description
PS_THRES_HIGH LSB	0xA9	11111111	PS upper interrupt threshold value, LSB
PS_THRES_HIGH MSB	0xAA	11111111	PS upper interrupt threshold value, MSB
PS_THRES_LOW LSB	0xAB	00000000	PS lower interrupt threshold value, LSB
PS_THRES_LOW MSB	0xAC	00000000	PS lower interrupt threshold value, MSB

OPTICAL SENSOR LTR-X150P

PS_OFFSET Register (0xAD – 0xAE) (Read/Write)

PS_OFFSET registers let user define PS crosstalk of the device. PS data will be subtracted by this OFFSET value if PS_OS is enabled at register 0x81.

Field	Register	Default	Description
PS Offset LSB	0xAD	0	PS offset data lower byte
PS Offset MSB	0xAE	0	PS offset data higher byte

PART_ID Register (0xB3) (Read Only)

The PART_ID register defines the part number and revision identification of the sensor.

0xB3	PART_ID (default = 0x9C)							
	Bit 7	Bit 6	Bit 5	Bit 4	Bit 3	Bit 2	Bit 1	Bit 0
	Part Number ID						Revision ID	

MANUFAC_ID Register (0xB4) (Read Only)

The MANUFAC_ID register defines the manufacturer identification of the sensor.

0xB4	MANUFAC_ID (default = 0x05)							
	Bit 7	Bit 6	Bit 5	Bit 4	Bit 3	Bit 2	Bit 1	Bit 0
	Manufacturer ID							

PS_CONFIG_1 Register (0xB6) (Read/Write)

Field	Bits	Default	Description
Reserved	7:0	11110101	Must write as 11000101

OPTICAL SENSOR LTR-X150P

PS_CONFIG_2 Register (0xDB) (Read/Write)

Field	Bits	Default	Description
Reserved	7:0	00010100	A different value may be recommended depending on application

PS_CONFIG_3 Register (0xE3) (Read/Write)

Field	Bits	Default	Description
Reserved	7:0	01100111	A different value may be recommended depending on application

PS_CONFIG_4 Register (0xF9) (Read/Write)

Field	Bits	Default	Description
Reserved	7:0	10001111	A different value may be recommended depending on application

PS_DIODE_SELECT Register (0xD8) (Read/Write)

0xD8	PS_DIODE_SELECT (default = 0x0F)							
	Bit 7	Bit 6	Bit 5	Bit 4	Bit 3	Bit 2	Bit 1	Bit 0
	Reserved				CH0_3	CH0_2	CH0_1	CH0_0

Field	Bits	Default	Description	
Reserved	7:4	0000	Must write 0000	
DIODE3 switch	3	1	0	OFF
			1	ON (default)
DIODE2 switch	2	1	0	OFF
			1	ON (default)
DIODE1 switch	1	1	0	OFF
			1	ON (default)

OPTICAL SENSOR LTR-X150P

DIODE0 switch	0	1	0	OFF
			1	ON (default)

7. Application Information

7.1 Operating Mode

Stand-by Mode

The device is by default in stand-by mode after power-up. No measurement activity will be done. I2C protocol allows communication to read/write to the registers. The device can be reset from MCU by setting appropriate register control (SW reset). Start-up sequence is exactly the same as when power-on reset is triggered.

Active Mode

Measurement data is expected to be available within a known fixed time.

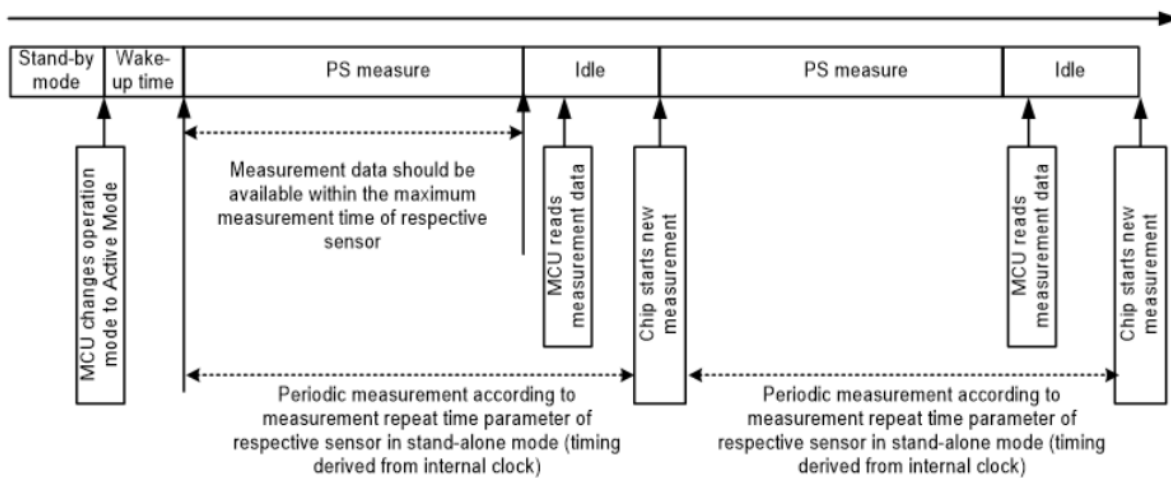

Figure 7.2.1 : PS measurement sequence

7.2 Interrupt Features

The interrupt function is active if PS measurements are outside of the upper and lower absolute threshold levels set in the appropriate threshold register. Only newly measured data is compared to the threshold levels set such

OPTICAL SENSOR LTR-X150P

that old data will not cause triggering of the INT pin if in case the threshold levels are changed in between measurements.

The status of interrupt can be monitored directly through the interrupt (INT) pin or by checking contents of the interrupt register. Interrupt pin can either be enable or disabled. Possible to invert interrupt output of LOW or HIGH state. Interrupt pin IO requirements are exactly the same as those of the I2C bus pins SDA and SCL.

There are two user selectable type of interrupts, which are window interrupt type & logic interrupt type. Refer to Figure 7.3.1 and 7.3.2 for illustration.

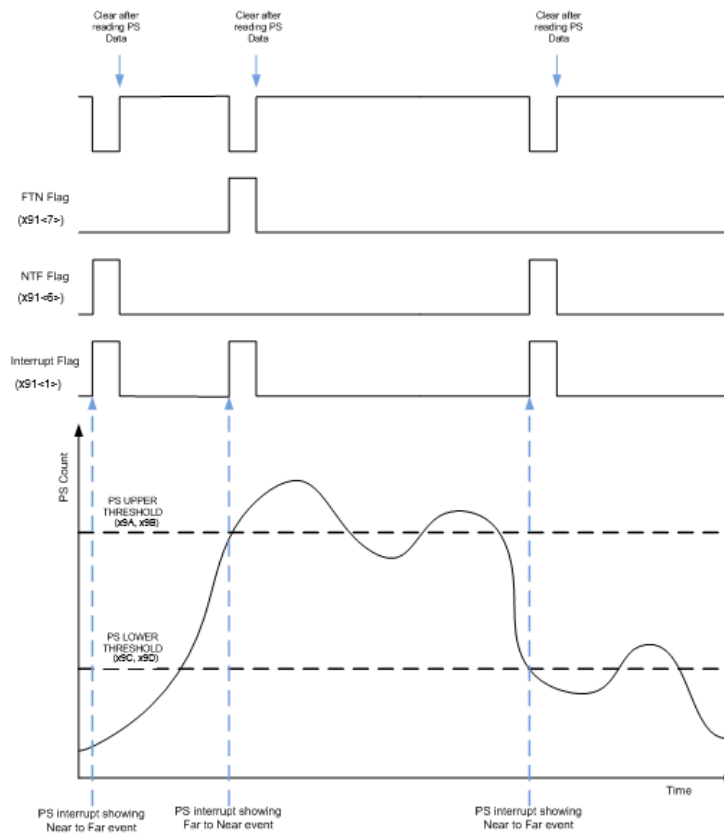

Figure 7.3.1 : Interrupt illustration on logic type (with NTF/FTN reporting)

(Logic Mode: activated by control register PS_CONTR (0x81<2>) and INTERRUPT (0xA7<1>))

OPTICAL SENSOR LTR-X150P

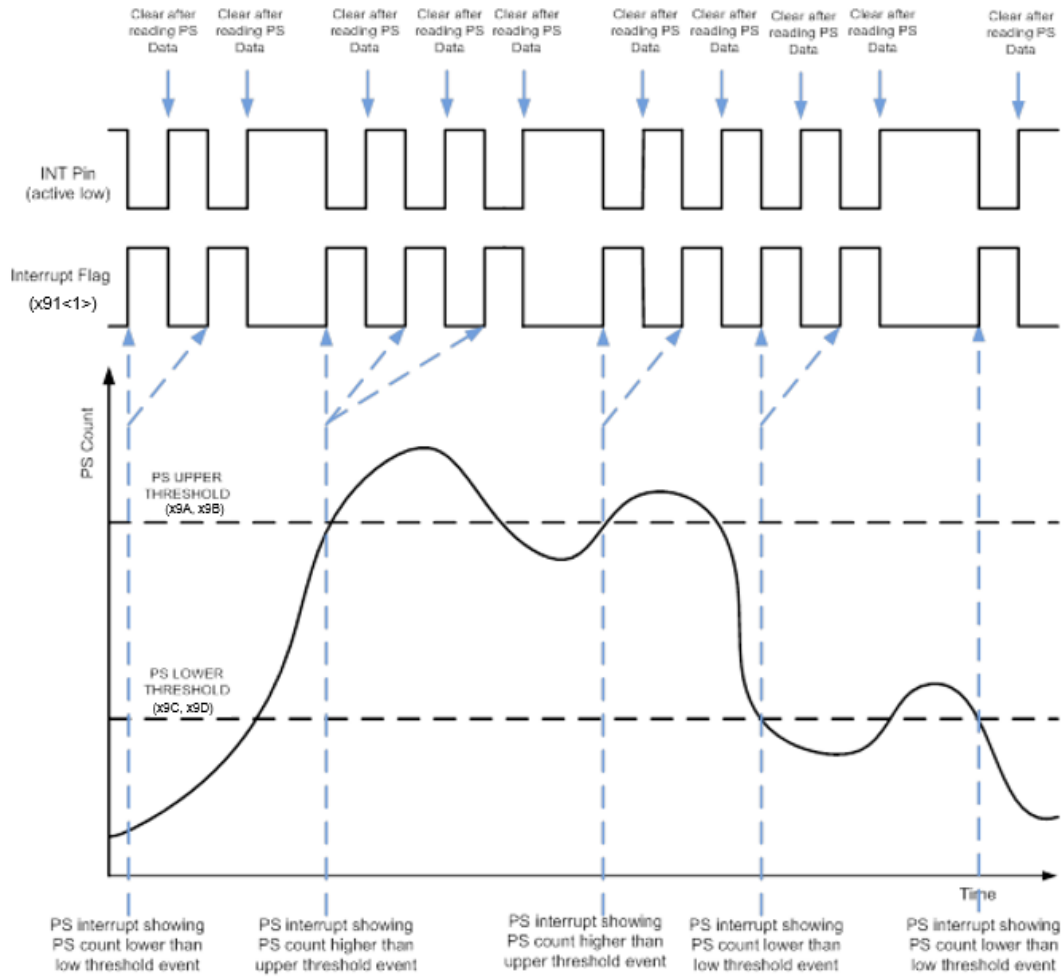
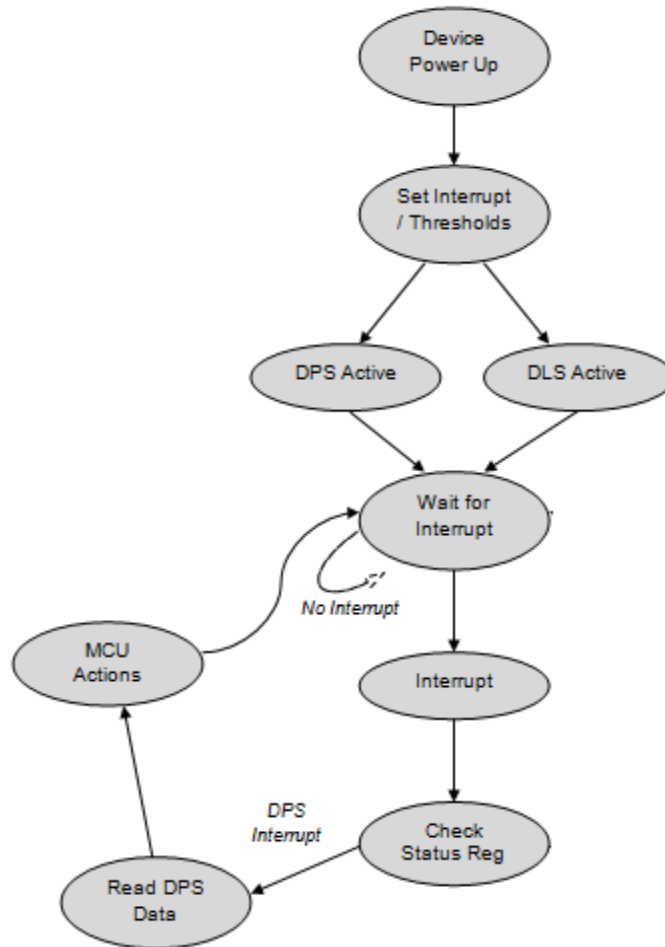

Figure 7.3.2 : Interrupt illustration on window type (by default, without NTF/FTN reporting)

OPTICAL SENSOR LTR-X150P

Flow diagram below illustrates the operation flow, and involving the use of Thresholds and interrupt.



OPTICAL SENSOR LTR-X150P

8. Recommended Leadfree Reflow Profile

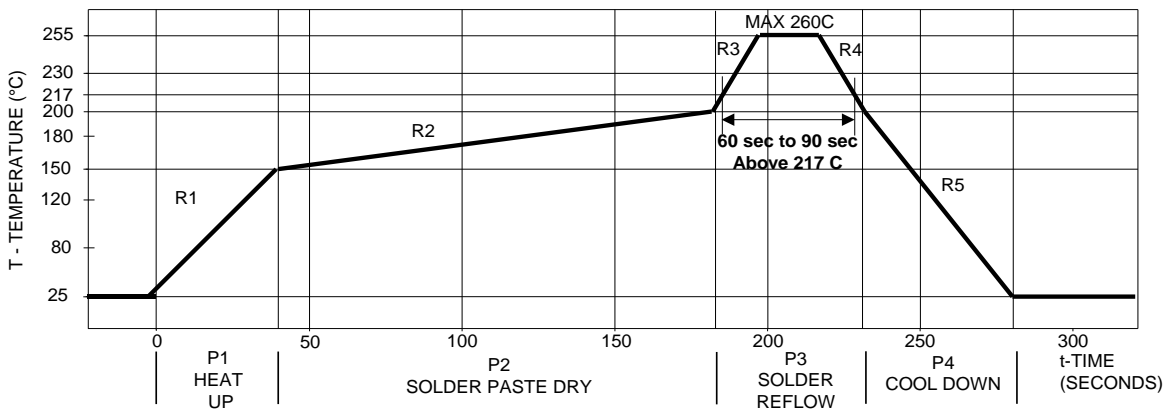

Process Zone	Symbol	ΔT	Maximum $\Delta T/\Delta time$ or Duration
Heat Up	P1, R1	25°C to 150°C	3°C/s
Solder Paste Dry	P2, R2	150°C to 200°C	100s to 180s
Solder Reflow	P3, R3	200°C to 260°C	3°C/s
	P3, R4	260°C to 200°C	-6°C/s
Cool Down	P4, R5	200°C to 25°C	-6°C/s
Time maintained above liquidus point , 217°C		> 217°C	60s to 90s
Peak Temperature		260°C	-
Time within 5°C of actual Peak Temperature		> 255°C	20s
Time 25°C to Peak Temperature		25°C to 260°C	8mins

It is recommended to perform reflow soldering no more than twice.

9. Moisture Proof Packaging

All LTR-X150P are shipped in moisture proof package. Once opened, moisture absorption begins. This part is compliant to JEDEC J-STD-033A Level 3.

10.1 Shelf Life

Device has the shelf life of 12 months if stored in an unopened moisture proof package. It is recommended to store in following condition.

- Shelf Life : 12 months
- Ambient Temperature : <40°C
- Relative Humidity: <90%

10.2 Floor Life

After removal from the moisture barrier bag, the parts should be stored at the recommended storage conditions and soldered within seven days.

- Floor Life : 168 hours
- Ambient Temperature : <30°C
- Relative Humidity: <60%

10.3 Rebaking information

When the moisture barrier bag is opened and the parts are exposed to the recommended storage conditions for more than seven days, the parts must be baked before reflow to prevent damage to the parts.

Baking Conditions

Package	Temperature	Time
In Reels	60°C	48 hours
In Bulk	100°C	4 hours

Baking should only be done once.

10. Recommended Land Pattern and Metal Stencil Aperture

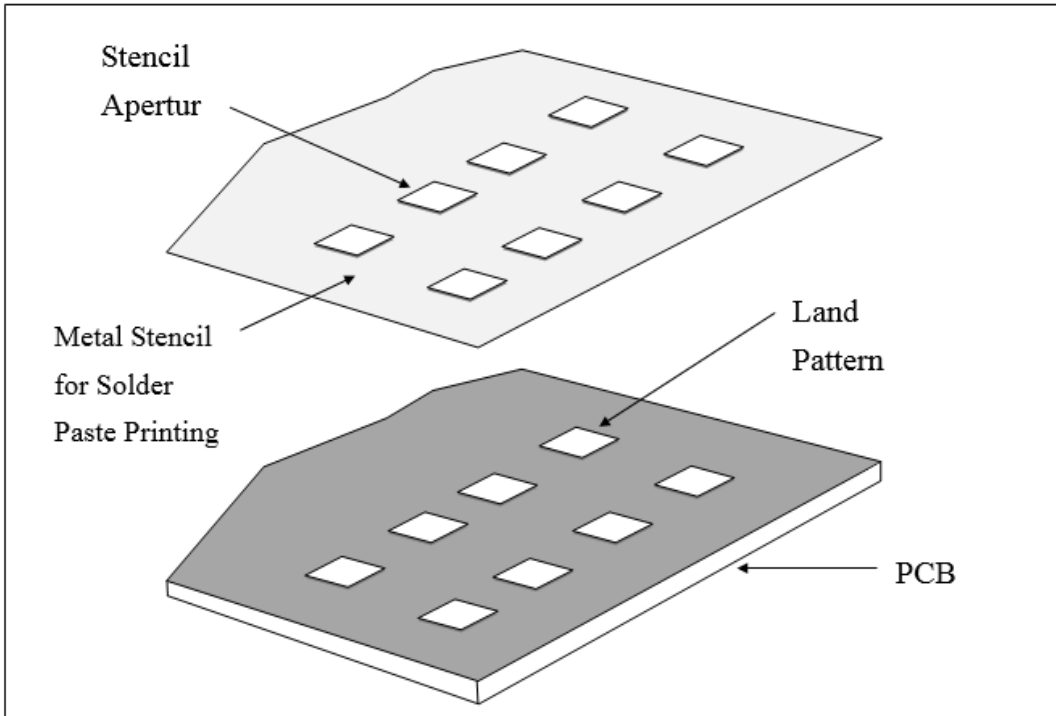

Recommended Land Pattern

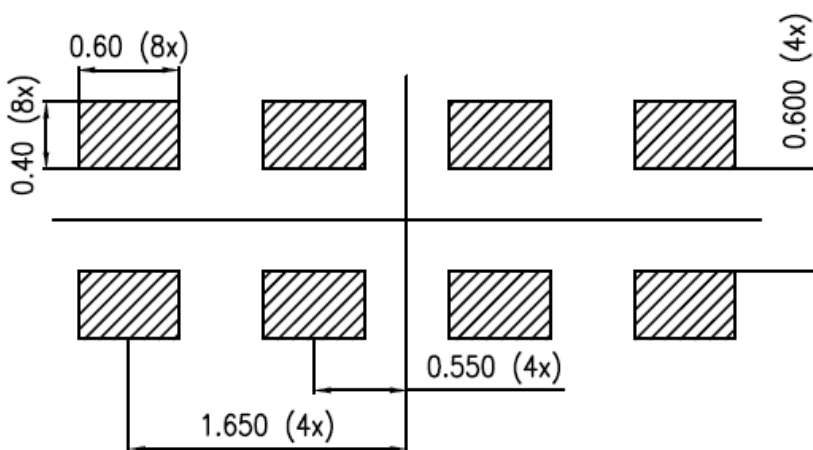

Note: All dimensions are in millimeters

OPTICAL SENSOR LTR-X150P

Recommended Metal Stencil Aperture

It is recommended that the metal stencil used for solder paste printing has a thickness (t) of 0.11mm (0.004 inches / 4 mils) or 0.127mm (0.005 inches / 5 mils).

The stencil aperture opening is recommended to be 0.40mm x 0.60mm which has the same dimension as the land pattern. This is to ensure adequate printed solder paste volume and yet no shorting.

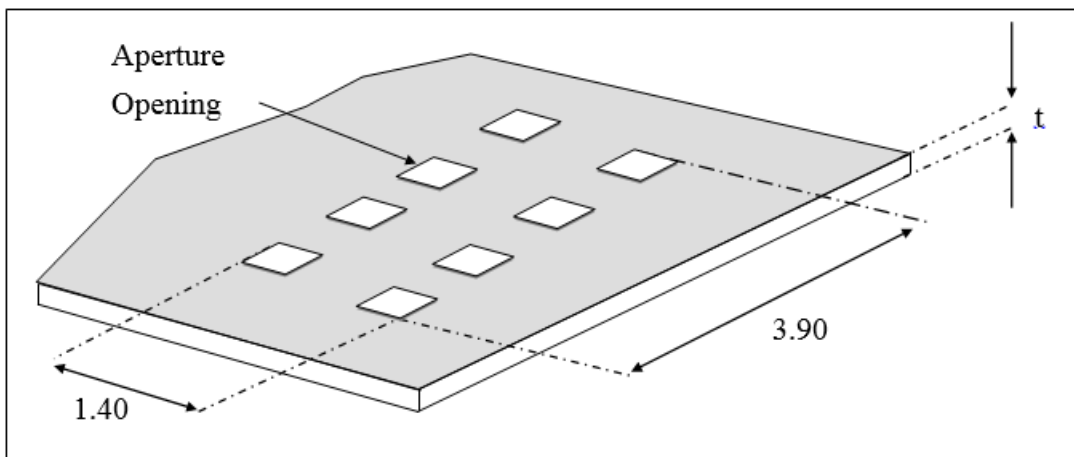

OPTICAL SENSOR LTR-X150P

11. Package Dimension for Tape and Reel

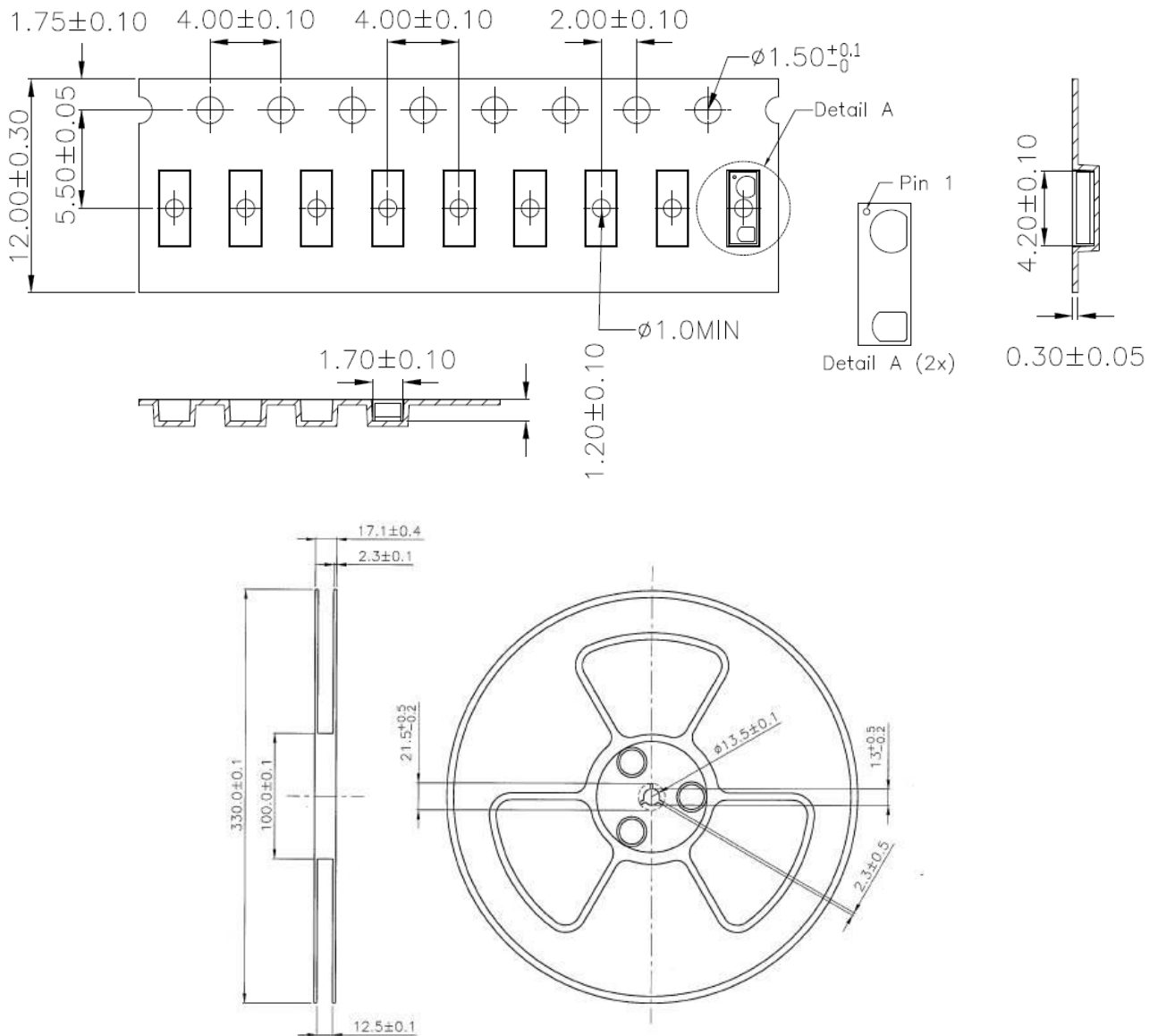

Notes:

1. All dimensions are in millimeters
2. Empty component pockets sealed with top cover tape
3. 13 inch reel – 10,000 pieces per reel
4. In accordance with ANSI/EIA 481-1-A-1994 specification

X-ON Electronics

Largest Supplier of Electrical and Electronic Components

Click to view similar products for [Proximity Sensors](#) category:

Click to view products by [Lite-On](#) manufacturer:

Other Similar products are found below :

[70.340.1028.0](#) [70.360.2428.0](#) [8027AL20NL2CPXX](#) [9221350022](#) [922AA2W-A9P-L](#) [GL-12F-C2.5X10\(LOT3\)](#) [972AB3XM-A3P-L](#) [PS3251](#)
[980659-1](#) [E2E2-X5M41-M4](#) [E2E-X14MD1-G](#) [E2E-X2D1-G](#) [E2E-X4MD1-G](#) [E2E-X5E1-5M-N](#) [E2E-X5Y2-N](#) [EH-302](#) [EI3010TBOP](#)
[MS605AU](#) [EP175-32000](#) [IC08ANC15PO-K](#) [IFRM04P1513/S35L](#) [IFRM06P1703/S35L](#) [IFRM08P1501/S35L](#) [IFRM12N17G3/L](#)
[IFRM12P3502/L](#) [IFRM12P37G1/S14L](#) [ILFK12E9189/I02](#) [ILFK12E9193/I02](#) [OISN-013](#) [25.332.0653.1](#) [25.352.0653.0](#) [25.352.0753.0](#)
[25.523.3253.0](#) [9151710023](#) [922AA1HI-A4P-L](#) [922AA2XM-B9P-L](#) [922FS0.8-H4P-G-020](#) [922FS1.5C-A4P-Z774](#) [SC606ABV0S30](#)
[SM552A100](#) [SM851A1200FP](#) [F3S-A162-U](#) [GL-12F-C2X10\(LOT10\)](#) [GL-8HIBX10](#) [QT-08L](#) [RDS-DIN3-PA-D1](#) [34.110.0010.0](#) [3U02](#) [TL-](#)
[C2MF1-M3-E4](#) [TLX5C1GE](#)