

SMD PLCC Packages with IC Embedded Solutions



Application Note- Hardware/Software Design Guidelines

AN No.500301, Ver.: 3.0

Abstract

As LED matrices, strips and strings products have a world trend in becoming brighter, easier, and simpler in design, LEDs with IC-chip embedded have emerged as a revolutionary practical concept contributing to cut back on design complexity, cost and schedule on both hardware and software. LITEON offers a wide selection of PLCC IC solution packages to its customers to meet several different application needs.

LITEON's LEDs with IC-chip embedded have successfully been designed into high-tech electronics which require visual effects with transparent designs to convey impressive advertisement for worldwide viewers.

This application note clearly describes a practical circuit reference design and its required surrounding components, to help users reduce design-in difficulties and shorten project development period. The purpose of this application note is to help users reduce unnecessary failures in the project development stages.

Scope

The content of this application note applies to the following LITEON P/N:

LTST-G563EGBW-HMX(X=2, 3, 4)/E563CEGBK/E563CEGBW (Note-A.)

LTST-E563CHEGBW (Note-A.)

LTST-E683CEGBK/E683CHEGBW (Note-B.)

LTST-G353CEGB7K/G353CEGB7W (Note-C.)

LTST-416CEGB1W (Note-D.)

LTST-416CEGBW (Note-E.)

Note:

- A. 5050 PLCC, 4-pins with 8-bit color grayscale.
- B. 3528 PLCC, 4-pins with 8-bit color grayscale.
- C. 3535 PLCC, 6-pins with 10-bit color grayscale and 4-bit current tunable.
- D. 4517 top/side view PLCC, 1.6t 6-pins with 10-bit color grayscale.
- E. 4517 top/side view PLCC, 1.6t 6-pins with 8-bit color grayscale.

Table of Contents

Abstract

Scope

A. LITEON IC Embedded Product Details

- i. LED Applied in the Packages
- ii. Differences in Driver Chip Performances
- iii. Driver Operation Block Diagram
 1. 8-bit/10-bit Driver IC
 2. 14-bit Driver IC

B. Circuit Design Guidelines

- i. Cascading Connection for 8-bit/10-bit Driver IC
- ii. Cascading Connection for 14-bit Driver IC

C. System Operation Timing Guidelines

- i. For 8-bit Driver IC
- ii. For 10-bit Driver IC
- iii. For 14-bit Driver IC

D. Reference Waveform Timings

Take 8-bit IC for example – Serial Connection for Two LEDs

About LITEON

Appendix. Reference Control Code

- i. For 8-bit Driver IC
- ii. For 10-bit Driver IC
- iii. For 14-bit Driver IC

A. LITEON IC Embedded Solutions – Product Line-up and Comparison

LITEON IC embedded series uses driver chips that come from high-end Taiwan-based chip-design houses. It contains 3 channels, PWM-embedded, and constant current output.

Part No.	Embedded IC Performance	Brightness		Current Adjustable	Resumes Data Transmission	Cascade Capability
		IC Driving Current	Mix White Avg.			
LTST-G563EGBW-HMX LTST-E563CEGBK(W)	8-bit static driving	5mA/ each channel	900 mcd	No	No	Unlimited
LTST-E563CHEGBW	8-bit static driving	18mA/ each channel	2000 mcd	No	No	Unlimited
LTST-E683CEGBK	8-bit static driving	5mA/ each channel	500 mcd	No	No	Unlimited
LTST-E683CHEGBW	8-bit static driving	18mA/ each channel	1500 mcd	No	No	Unlimited
LTST-G353CEGB7K(W)	14-bit static driving	5mA/ each channel	1000 mcd	Yes	Yes	Unlimited
LTST-416CEGB1W	10-bit static driving	5mA/ each channel	900 mcd	No	No	Unlimited
LTST-416CEGBW	8-bit static driving	5mA/ each channel	900 mcd	No	No	Unlimited

i. LED Chip Applied in the Packages

LITEON's G563/E563/G353/E683/416C series are using EPISTAR dice which provides mid-high intensity output to meet video/decorative effects.

ii. Differences in Driver Chip Performances

	8-bit Driver IC	10-bit Driver IC	14-bit Driver IC
Grayscale	$2^8 \times 2^8 \times 2^8 = 2^{24}$ colors	$2^{10} \times 2^{10} \times 2^{10} = 2^{30}$ colors	$2^{10} \times 2^{10} \times 2^{10} = 2^{30}$ colors
Current Tunable	NA	NA	$2^4 \times 2^4 \times 2^4 = 2^{12}$ steps
Serial Data Pin	Data_in, Data_out	Data_in, Data_out	Data_in, Data_out, Auxiliary Data_in
Clock Pin	No clock pin required	No clock pin required	No clock pin required
VDD	3.8~5.5V	3.8~5.5V	3.8~5.5V
Current Setting	5mA/18mA to LED dice (Fixed current)	5mA to LED dice (Fixed current)	5mA to LED dice (Fixed current)
ESD (IC)	8KV	8KV	8KV
Functional Frame	Not built-in	Not built-in	Not built-in
Resumes Data Transmission	NO	NO	YES

iii. Driver Operation Block Diagram

1. 8-bit/10-bit Driver IC
(8-bit/10-bit color grayscale)

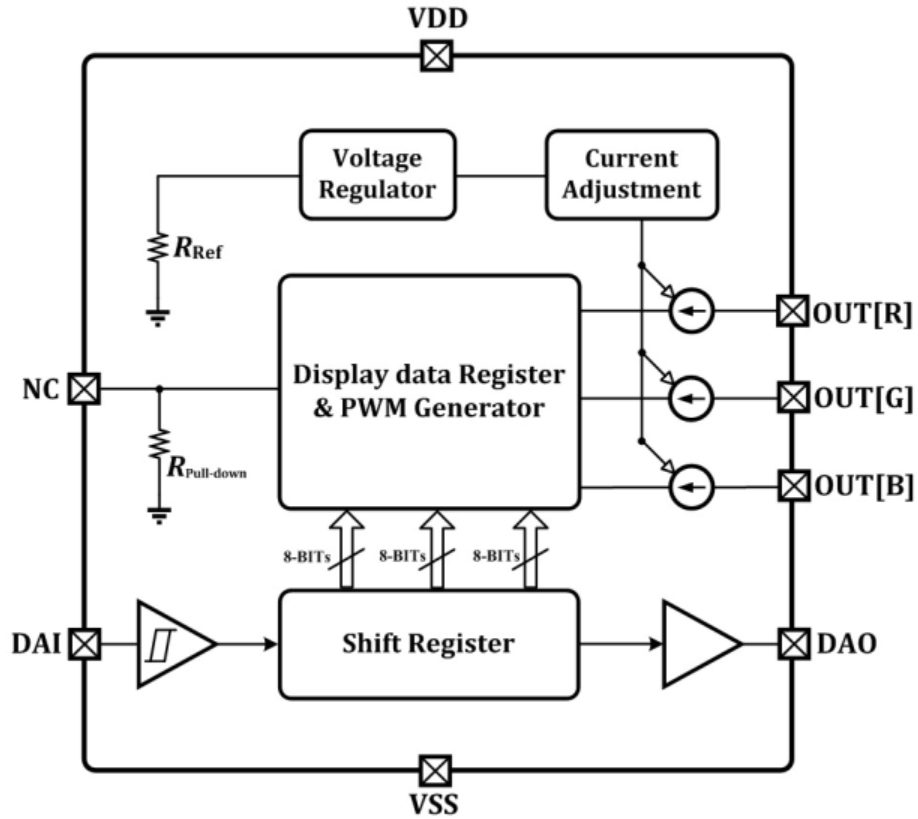

Pad Names	Function Descriptions
NC	NC in the package
DAI	Serial DATA_IN
DAO	Serial DATA_OUT
VDD	Input DC voltage
VSS	Ground
OUT[R]	Connection to red LED dice
OUT[G]	Connection to green LED dice
OUT[B]	Connection to blue LED dice

2. 14-bit Driver IC
(10-bit color grayscale and 4-bit current tunable)

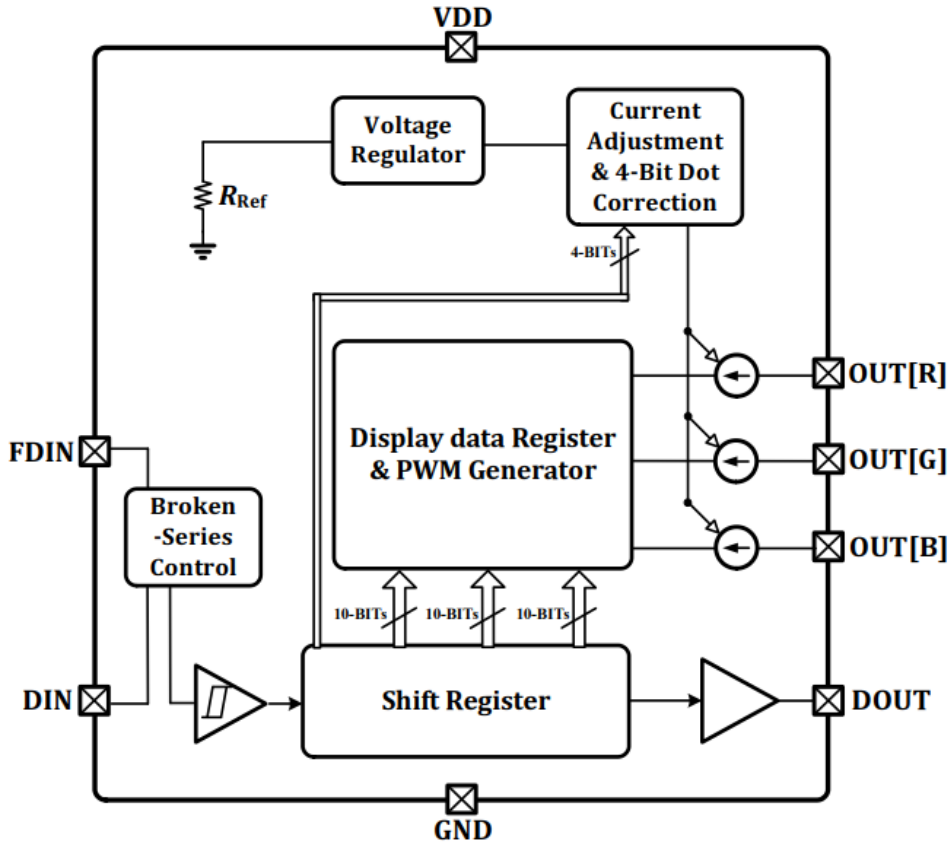

Pad Names	Function Descriptions
FDIN	Auxiliary Serial DATA_IN
DIN	Serial DATA_IN
DOUT	Serial DATA_OUT
VDD	Input DC voltage
GNG	Ground
OUT[R]	Connection to red LED dice
OUT[G]	Connection to green LED dice
OUT[B]	Connection to blue LED dice

B. Circuit Design Guidelines

i. Cascading Connection for 8-bit/10-bit Driver IC

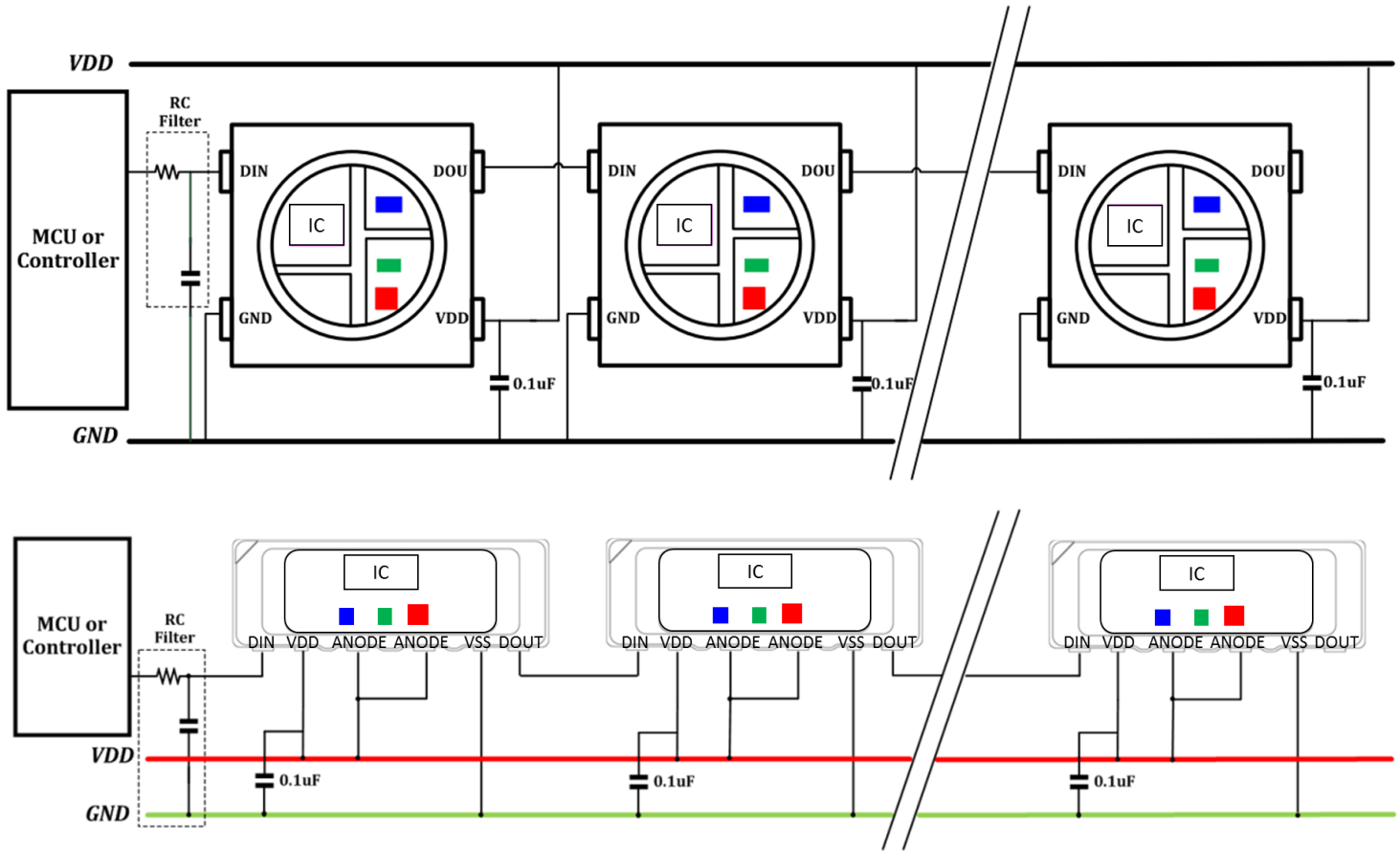

ii. Cascading Connection for 14-bit Driver IC

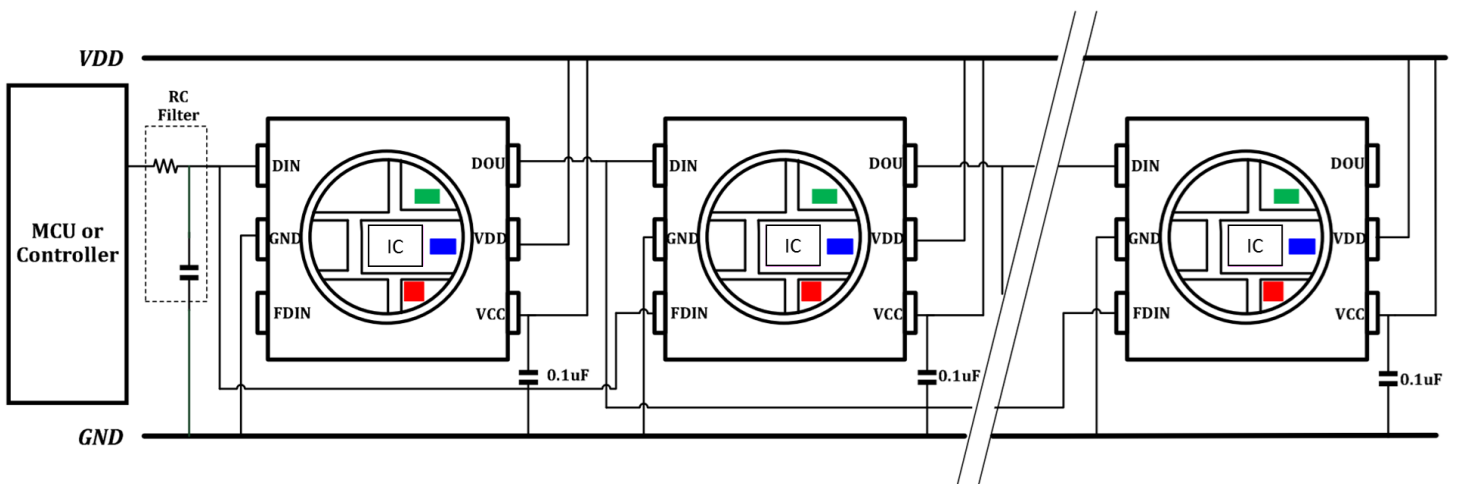

Note:

Bypass capacitor is necessary in the design to guarantee good power feed quality and cascade stability. It's preferred to put capacitors near each LED.

C. System Operation Timing Guidelines

i. For 8-bit Driver IC

G563/E563/E683/416C product series use single communication wire for LED PWM control. After power on reset, the IC will fetch the first 24-bit data and latch to the shift-register itself. Then the second 24-bit data will be passed to next chip. The embedded IC has auto waveform reshaping amplification technology, and makes it able to be used on long cascading applications. The LED PWM output controlled by duty ration which depends on the 24-bit data each for RGB outputs. All chips will latch new data when DIN port receives the reset signal (50us low-level signal).



Fig. 1 Data Communication

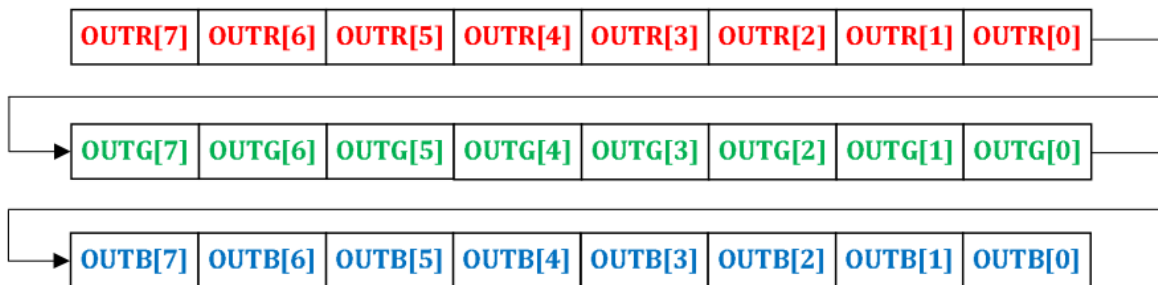

Fig. 2 Single Data in 24-bit for RGB

ii. For 10-bit Driver IC

416C product series uses single communication wire for LED PWM control. After power on reset, the IC will fetch the first 30-bit data and latch to the shift-register itself. Then the second 30-bit data will be passed to next chip. The Embedded IC has auto waveform reshaping amplification technology, and makes it able to be used on long cascading applications. The LED PWM output controlled by duty ration which depends on the 30-bit data each for RGB outputs. All chips will latch new data when DIN port receives the reset signal (50us low-level signal).

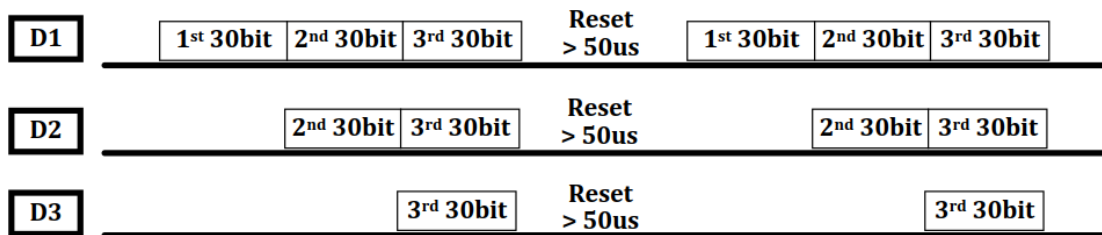

Fig. 1 Data Communication

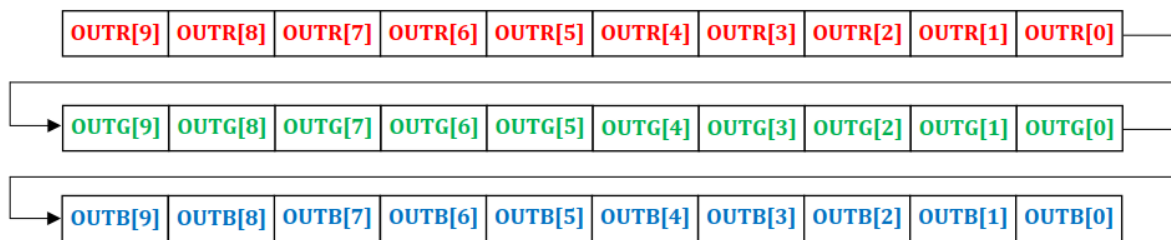

Fig. 2 Single Data in 30-bit for RGB

iii. For 14-bit Driver IC (4bits for current tunable; 10bits for color grayscale)

G353 product series uses single communication wire for LED PWM control. After power on reset, the IC will fetch the first 42-bit data and latch to the shift-register itself. Then the second 42-bit data will be passed to next chip. The Embedded IC has auto waveform reshaping amplification technology, and makes it able to be used on long cascading applications. The LED PWM output controlled by duty ration which depends on the 42-bit data each for RGB outputs. All chips will latch new data when DIN port receives the reset signal (50us low-level signal).

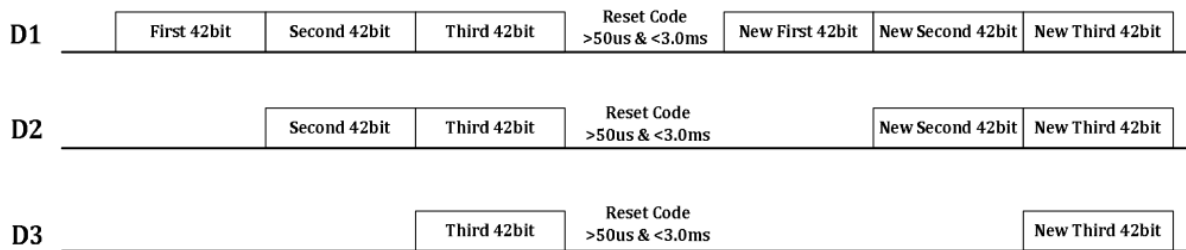

Fig. 1 Data Communication

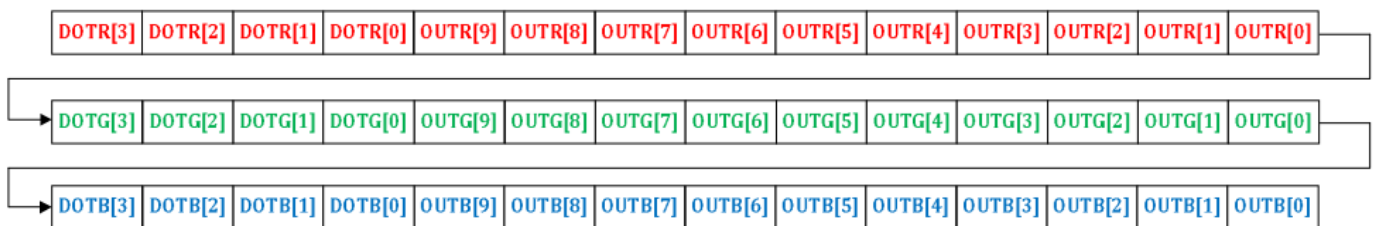
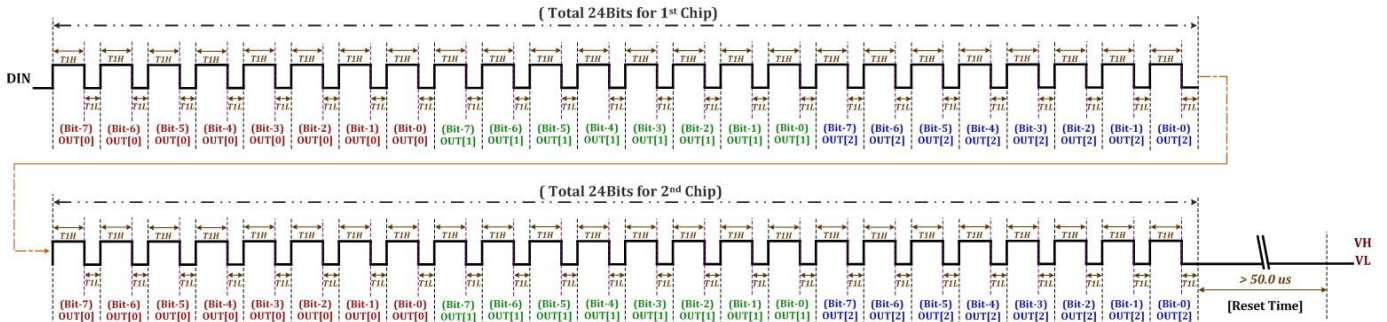

Fig. 2 Single Data in 42-bit for RGB

D. Reference Waveform Timing

Take 8-bit IC for example: (DIN / DOUT) – Serial Connection for Two LEDs,

[Input-Data_Pattern: Turn-on all Three Channels with Full 255-steps Grayscale]



[Output-Data_Pattern: Turn-on all Three Channels with Full 255-steps Grayscale]

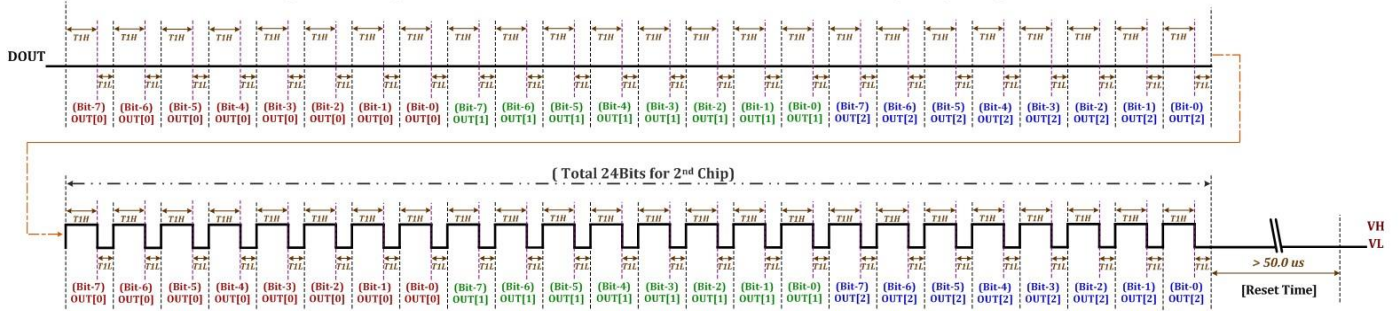

Note:

LITEON P/N	T0H	T0L	T1H	T1L	Allowance
8-bit IC	300ns	900ns	900ns	300ns	80ns
10-bit IC	300ns	900ns	900ns	300ns	80ns
14-bit IC	300ns	900ns	900ns	300ns	80ns

About LITEON

Founded in 1975, LITEON Technology is the longest running and largest-scale optoelectronic components supplier in Taiwan; based on the strong R&D resources, LITEON has been able to cover extensive optoelectronic product lines including White LEDs, SMD LEDs, Lamp LEDs, LED Displays, Photo-couplers, Infrared Components etc. And it's proven to be the leader in total optoelectronic components solutions.

Optoelectronic components from LITEON have been highly acclaimed and used by leading brands of information products, consumer electronics, and communication equipment. LITEON optoelectronic components are widely used for applications ranging from indicators and displays of household electronic appliances, backlights of personal handheld devices and IT products, to active and passive lights in car electronics, industrial optoelectronic sensors, and light sources for all purposes.

Building on its professional packaging designs and sophisticated manufacturing experiences, LITEON Technology not only has been able to provide customers with high-quality optoelectronic components solutions, but has also been constantly pursuing for high-performance and low-pollutant light sources as its major goal.

X-ON Electronics

Largest Supplier of Electrical and Electronic Components

Click to view similar products for [Standard LEDs - SMD category](#):

Click to view products by [Lite-On manufacturer](#):

Other Similar products are found below :

[LTST-C19GD2WT](#) [LTST-N683GBEW](#) [597-3006-607F](#) [597-3403-607F](#) [LTW-K140SZR40](#) [LTW-M140ZVS](#) [598-8110-100F](#) [598-8170-100F](#)
[598-8610-202F](#) [7012X7](#) [AAAF5060QBFSEEZGS](#) [12-22SURSYGC/S530-A3/E2/TR8](#) [1383SURT/S530-A3/TR1\(R\)](#) [APT1608QGW](#)
[EASV1803BA0](#) [HT-F104TW-5860](#) [SML310BATT86](#) [SML-512VWT86A](#) [SML-LX0606SISUGC/A](#) [SML-LXL1307SRC-TR](#) [SML-](#)
[LXR851SIUPGUBC](#) [LT1ED53A](#) [17-21/G6C-FM1N2B/3T](#) [FAT801-S](#) [SSL-LXA227IC-TR31A](#) [AM27ZGC03](#) [APB3025SGNC](#)
[APHK1608VGCA](#) [APT2012QGW](#) [CLMVC-FKA-CA1E1L81BB7C3C3](#) [CLYBA-FKA-CFHHL9BBB7A363](#) [CMD11504UR](#) [LTW-](#)
[020ZDCG](#) [LTW-21TS5](#) [LTW-K140SZR30](#) [HSMY-C177](#) [HT-121UYG-4739](#) [UYGT801-S](#) [KVH1C100MF6R](#) [42-21SYGC/S530-E1/TR8](#)
[YGFR411-H](#) [597-2311-402F](#) [5973212407NF](#) [597-3302-607F](#) [597-5202-407F](#) [598-8330-117F](#) [SAW8WA2A-L35M40-CA](#) [SML013WBDW1](#)
[SML522BUWT86](#) [SML-LX0402IC-TR](#)