



Photocoupler
Product Data Sheet
LTV-3120-H Series

Spec No. :DS70-2018-0125
Effective Date: 09/22/2018
Revision: -

LITE-ON DCC

RELEASE

BNS-OD-FC001/A4

Photocoupler LTV-3120-H series

2.5 Amp Output Current IGBT Gate Drive Optocoupler with Rail-to-Rail Output Voltage, High CMR.

1. DESCRIPTION

The LTV-3120-H series Photocoupler is ideally suited for driving power IGBTs and MOSFETs used in motor control inverter applications and inverters in power supply system. It contains an AlGaAs LED optically coupled to an integrated circuit with a power output stage. The 2.5A peak output current is capable of directly driving most IGBTs with ratings up to 1200 V/100 A. For IGBTs with higher ratings, the LTV-3120-H series can be used to drive a discrete power stage which drives the IGBT gate.

The Photocoupler operational parameters are guaranteed over the temperature range from -40°C ~ +105°C.

1.1 Features

- ±2.5 A maximum peak output current
- Rail-to-rail output voltage
- Propagation delay time : $T_{PHL} = 200 \text{ ns (max)}$, $T_{PLH} = 200 \text{ ns (max)}$
- Under Voltage Lock-Out protection (UVLO) with hysteresis
- 35 kV/us minimum Common Mode Rejection (CMR) at $V_{CM} = 1500 \text{ V}$
- $I_{CC} = 3.0 \text{ mA}$ maximum supply current
- Wide operating range: 15 to 30 Volts (V_{CC})
- Guaranteed performance over temperature -40°C ~ +105°C.
- MSL Level 1
- Safety approval:
UL/ cUL Recognized 5000 $V_{RMS}/1 \text{ min}$
IEC/EN/DIN EN 60747-5-5 $V_{IORM} = 630 \text{ Vpeak}$

1.2 Applications

- Plasma Display Panel .
- IGBT/MOSFET gate drive
- Industrial Inverter
- Induction heating
- Uninterruptible power supply (UPS)

Functional Diagram

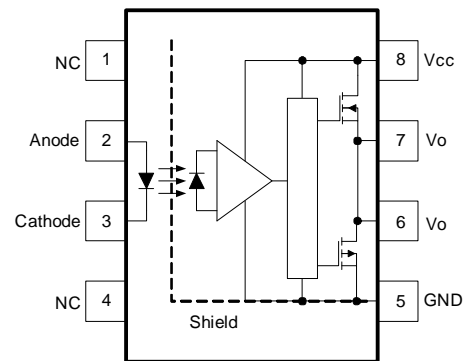

Truth Table

LED	V_{CC-GND} (Turn-ON, +ve going)	V_{CC-GND} (Turn-OFF, -ve going)	V_o
OFF	0 - 30 V	0 - 30 V	Low
ON	0 - 11.0 V	0 - 9.5 V	Low
ON	11.0 - 13.5 V	9.5 - 12 V	Transition
ON	13.5 - 30 V	12 - 30 V	High

A 0.1µF bypass Capacitor must be connected between Pin 5 and 8.

Photocoupler LTV-3120-H series

2. PACKAGE DIMENSIONS

2.1 LTV-3120-H

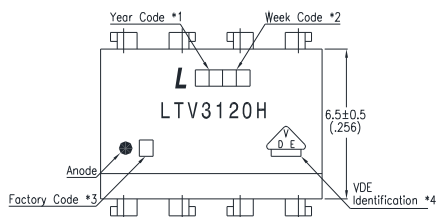

2.2 LTV-3120M-H

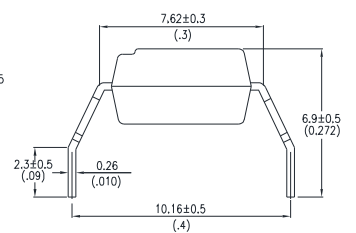
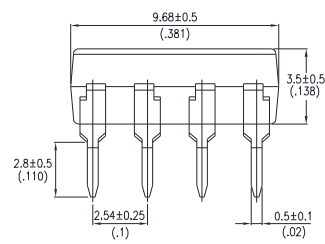
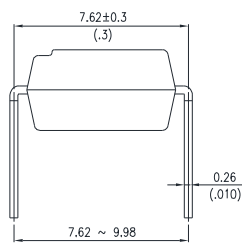
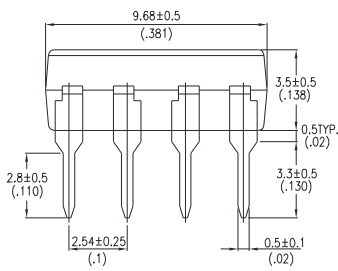
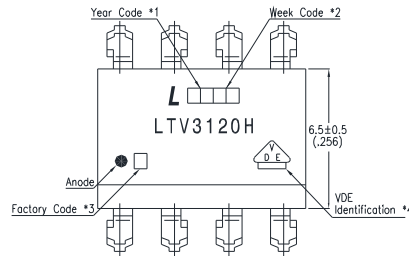

2.3 LTV-3120S-H

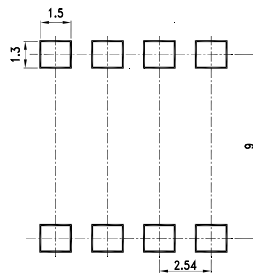
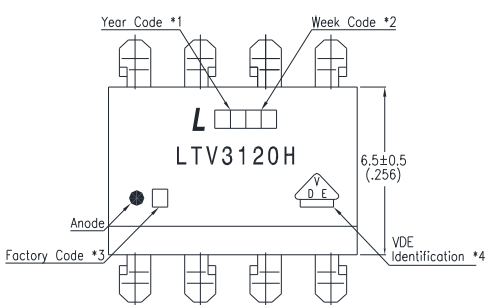

Notes :

- *1. Year date code.
- *2. 2-digit work week.
- *3. Factory identification mark (Y : Thailand).
- *4. VDE Identification (Option)

Dimensions are in Millimeters and (Inches).

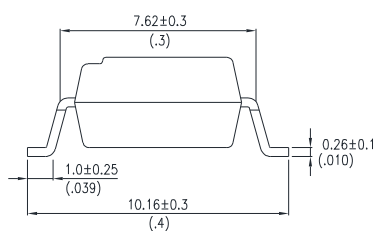
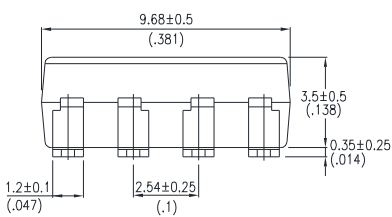

Photocoupler LTV-3120-H series

3. TAPING DIMENSIONS

3.1 LTV-3120S-TA-H

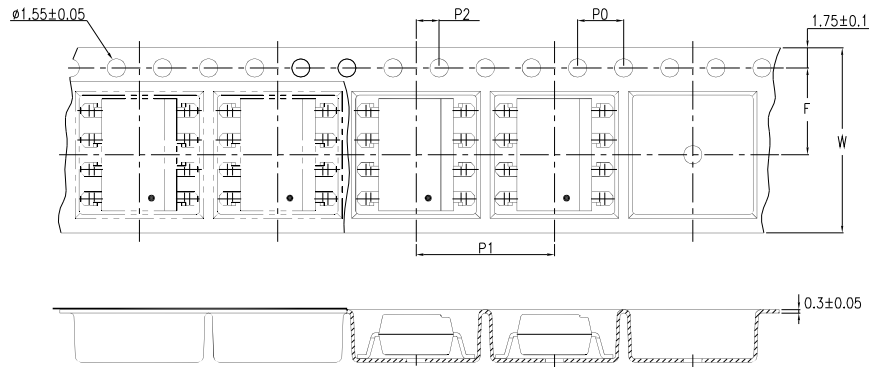

3.2 LTV-3120S-TA1-H

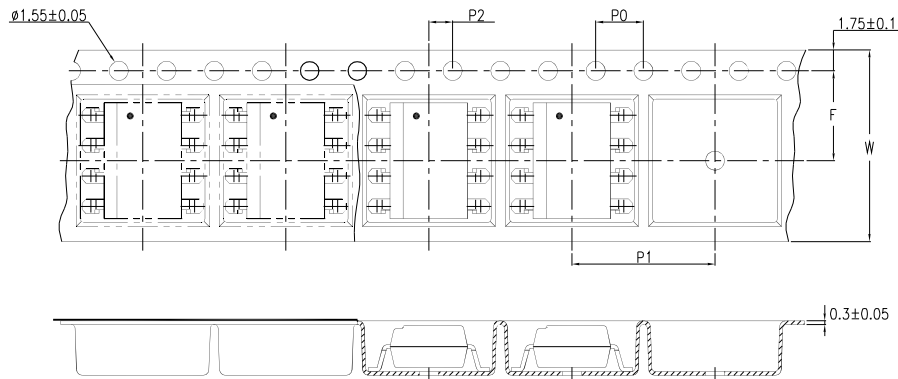

Description	Symbol	Dimension in mm (inch)
Tape wide	W	16±0.3 (0.63)
Pitch of sprocket holes	P ₀	4±0.1 (0.15)
Distance of compartment	F	7.5±0.1 (0.295)
	P ₂	2±0.1 (0.079)
Distance of compartment to compartment	P ₁	12±0.1 (0.47)

3.3 Quantities Per Reel

Package Type	TA / TA1
Quantities (pcs)	1000

Photocoupler LTV-3120-H series

4. RATING AND CHARACTERISTICS

4.1 Absolute Maximum Ratings

Parameter	Symbol	Min	Max	Unit	Note
Storage Temperature	T_{stg}	-55	+150	°C	—
Operating Temperature	T_{opr}	-40	+105	°C	—
Output IC Junction Temperature	T_J	—	125	°C	—
Total Output Supply Voltage	$(V_{CC}-V_{EE})$	0	35	V	—
Average Forward Input Current	I_F	—	20	mA	—
Reverse Input Voltage	V_R	—	5	V	—
Peak Transient Input Current	$I_{F(TRAN)}$	—	1.0	A	1
“High” Peak Output Current	$I_{OH(PEAK)}$	—	2.5	A	2
“Low” Peak Output Current	$I_{OL(PEAK)}$	—	2.5	A	2
Input Current (Rise/Fall Time)	$t_{r(IN)}/t_{f(IN)}$	—	500	ns	3
Output Voltage	$V_{O(PEAK)}$	—	35	V	—
Power Dissipation	P_I	—	45	mW	—
Output Power Dissipation	P_O	—	250	mW	—
Total Power Dissipation	P_T	—	295	mW	—
Lead Solder Temperature (10s)	T_{sol}	—	260	°C	—

Note: Ambient temperature = 25°C, unless otherwise specified. Stresses exceeding the absolute maximum ratings can cause permanent damage to the device. Exposure to absolute maximum ratings for long periods of time can adversely affect reliability.

Note: Note: A ceramic capacitor (0.1 μF) should be connected between pin 8 and pin 5 to stabilize the operation of a high gain linear amplifier. Otherwise, this Photocoupler may not switch properly. The bypass capacitor should be placed within 1 cm of each pin.

Note 1: Pulse width (PW) ≤ 1 μs, 300 pps

Note 2: Exponential waveform. Pulse width ≤ 0.3 μs, f ≤ 15 kHz

Note 3: The rise and fall times of the input on-current should be less than 500 ns

4.2 Recommended Operating Conditions

Parameter	Symbol	Min	Max	Unit
Operating Temperature	T_A	-40	105	°C
Supply Voltage	V_{CC}	15	30	V
Input Current (ON)	$I_{FL(ON)}$	7	16	mA
Input Voltage (OFF)	$V_{F(OFF)}$	0	0.8	V

Photocoupler LTV-3120-H series

4.3 ELECTRICAL OPTICAL CHARACTERISTICS

	Parameter	Symbol	Min.	Typ.	Max.	Unit	Test Condition	Figure	Note
Input	Input Forward Voltage	V_F	1.2	1.37	1.8	V	$I_F = 10\text{mA}$	13	—
	Input Forward Voltage Temperature Coefficient	$\Delta V_F / \Delta T$	—	-1.237	—	mV/°C	$I_F = 10\text{mA}$	—	—
	Input Reverse Voltage	BV_R	5	—	—	V	$I_R = 10\mu\text{A}$	—	—
	Input Threshold Current (Low to High)	I_{FLH}	—	2.4	5	mA	$V_{CC} = 30\text{V}, V_O > 5\text{V}$	6, 7, 18	-
	Input Threshold Voltage (High to Low)	V_{FHL}	0.8	—	—	V	$V_{CC} = 30\text{V}, V_O < 5\text{V}$	—	—
	Input Capacitance	C_{IN}	—	33	—	pF	$f = 1\text{MHz}, V_F = 0\text{V}$	—	—
Output	High Level Supply Current	I_{CCH}	—	1.7	3.0	mA	$I_F = 10\text{mA}, V_{CC} = 30\text{V}, V_O = \text{Open}$	4, 5	—
	Low Level Supply Current	I_{CCL}	—	1.8	3.0	mA	$I_F = 0\text{mA}, V_{CC} = 30\text{V}, V_O = \text{Open}$		—
	High level output current	I_{OH}	—	—	-1.0	A	$V_O = (V_{CC} - 1.5\text{V})$	16	1
			—	—	-2.5		$V_O = (V_{CC} - 4\text{V})$		2
	Low level output current	I_{OL}	1.0	—	—	A	$V_O = (V_{EE} + 1.5\text{V})$	17	1
			2.5	—	—		$V_O = (V_{EE} + 4\text{V})$		2
	High level output voltage	V_{OH}	$V_{CC} - 0.3$	$V_{CC} - 0.1$	—	V	$I_F = 10\text{mA}, I_O = -100\text{mA}$	1, 2, 14	—
	Low level output voltage	V_{OL}	—	$V_{EE} + 0.1$	$V_{EE} + 0.25$	V	$I_F = 0\text{mA}, I_O = 100\text{mA}$	3, 15	—
	UVLO Threshold	V_{UVLO+}	11.0	12.7	13.5	V	$V_O > 5\text{V}, I_F = 10\text{mA}$	19	—
			9.5	11.2	12.0	V	$V_O < 5\text{V}, I_F = 10\text{mA}$		—
UVLO Hysteresis	$UVLO_{HYS}$	—	1.5	—	V	—	—		

All Typical values at $T_A = 25^\circ\text{C}$ and $V_{CC} - V_{EE} = 30\text{V}$, unless otherwise specified; all minimum and maximum specifications are at recommended operating condition. (Refer to 4.2)

Note 1: Maximum pulse width = 50 μs .

Note 2: Maximum pulse width = 10 μs .

Photocoupler LTV-3120-H series

5. SWITCHING SPECIFICATION

Parameter	Symbol	Min.	Typ.	Max.	Unit	Test Condition	Figure	Note
Propagation Delay Time to High Output Level	t_{PLH}	50	130	200	ns	$R_g = 10\Omega$, $C_g = 25nF$, $f = 10\text{ kHz}$, Duty Cycle = 50% $I_F = 7\text{ to }16\text{ mA}$, $V_{CC} = 15\text{ to }30V$ $V_{EE} = \text{ground}$	8, 9, 10, 11, 12, 20	—
Propagation Delay Time to Low Output Level	t_{PHL}	50	130	200				—
Pulse Width Distortion	PWD	—	5	70				—
Propagation delay difference between any two parts or channels	PDD	-100	—	100				3
Output Rise Time (10 to 90%)	T_r	—	35	—			20	—
Output Fall Time (90 to 10%)	T_f	—	35	—				—
Common mode transient immunity at high level output	$ CM_H $	35	50	—			kV/ μ s	$T_A = 25^\circ\text{C}$, $I_F = 10\text{ to }16\text{ mA}$, $V_{CM} = 1500\text{ V}$, $V_{CC} = 30\text{ V}$
Common mode transient immunity at low level output	$ CM_L $	35	50	—	kV/ μ s	$T_A = 25^\circ\text{C}$, $V_F = 0\text{ V}$, $V_{CM} = 1500\text{ V}$, $V_{CC} = 30\text{ V}$	2	

All Typical values at $T_A = 25^\circ\text{C}$ and $V_{CC} - V_{EE} = 30\text{ V}$, unless otherwise specified; all minimum and maximum specifications are at recommended operating condition. (Refer to 4.2)

Note 1: CM_H is the maximum rate of rise of the common mode voltage that can be sustained with the output voltage in the logic high state ($V_O > 15\text{ V}$).

Note 2: CM_L is the maximum rate of fall of the common mode voltage that can be sustained with the output voltage in the logic low state ($V_O < 1\text{ V}$).

Note 3: The difference between t_{PHL} and t_{PLH} between any two parts series parts under same test conditions.

Photocoupler LTV-3120-H series

6. ISOLATION CHARACTERISTIC

Parameter	Symbol	Min.	Typ.	Max.	Unit	Test Condition	Note
Withstand Insulation Test Voltage	V_{ISO}	5000	—	—	V	RH ≤ 40%-60%, t = 1min, T _A = 25 °C	1, 2
Input-Output Resistance	R_{I-O}	—	10 ¹²	—	Ω	V _{I-O} = 500V DC	1
Input-Output Capacitance	C_{I-O}	—	0.92	—	pF	f = 1MHz, T _A = 25 °C	1

All Typical values at T_A = 25°C unless otherwise specified. All minimum and maximum specifications are at recommended operating condition. (Refer to 4.2)

Note 1: Device is considered a two terminal device: pins 1, 2, 3 and 4 are shorted together and pins 5, 6, 7 and 8 are shorted together.

Note 2: According to UL1577, each Photocoupler is tested by applying an insulation test voltage 6000V_{RMS} for one second (leakage current less than 10uA). This test is performed before the 100% production test for partial discharge

Photocoupler LTV-3120-H series

7. TYPICAL PERFORMANCE CURVES & TEST CIRCUITS

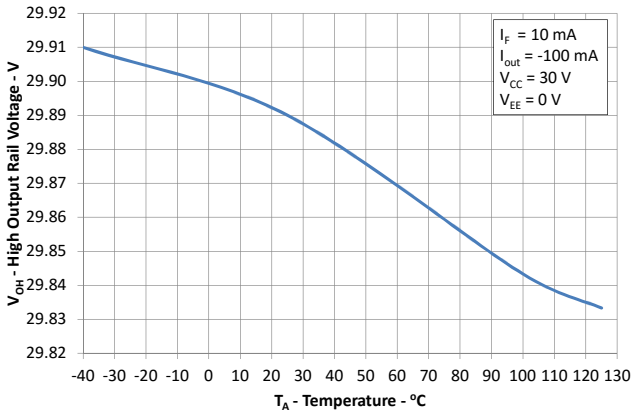

Figure 1: High output rail voltage vs. Temperature

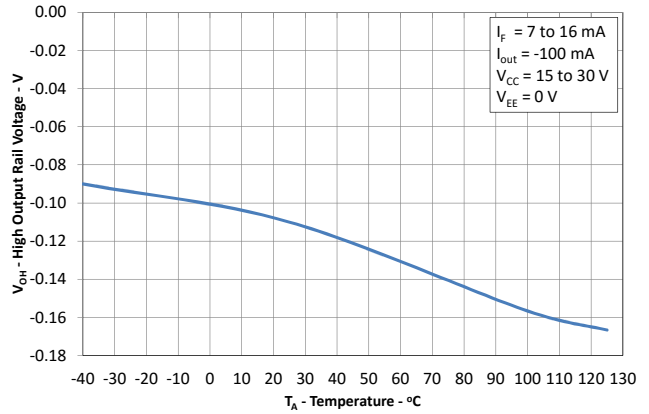

Figure 2: V_{OH} vs. Temperature

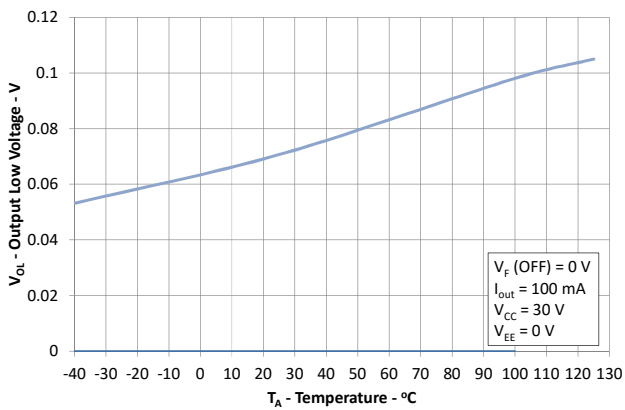

Figure 3: V_{OL} vs. Temperature

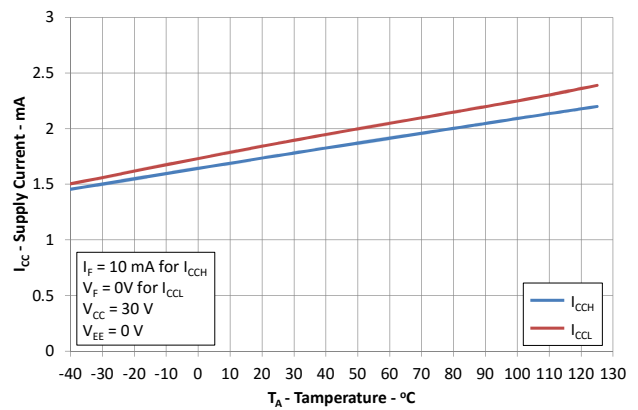

Figure 4: I_{CC} vs. Temperature

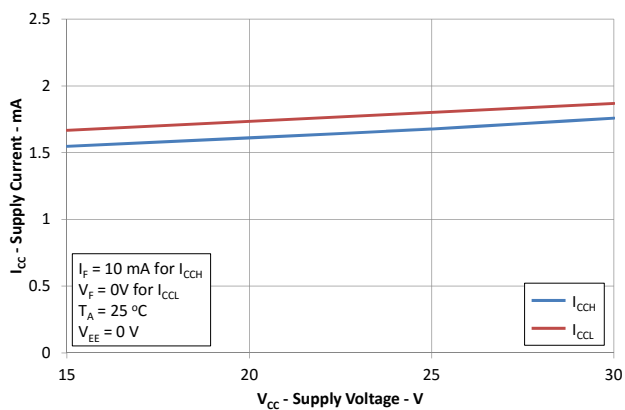

Figure 5: I_{CC} vs. V_{CC}

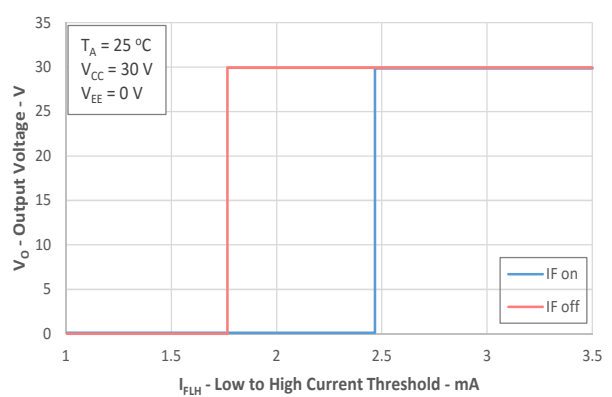

Figure 6: I_{FLH} Hysteresis

Photocoupler LTV-3120-H series

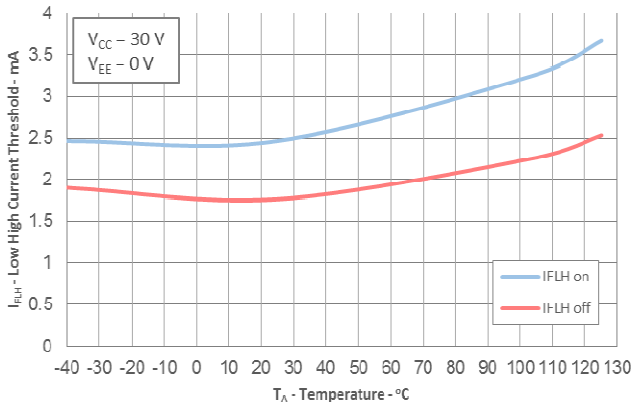

Figure 7: I_{FLH} vs. Temperature

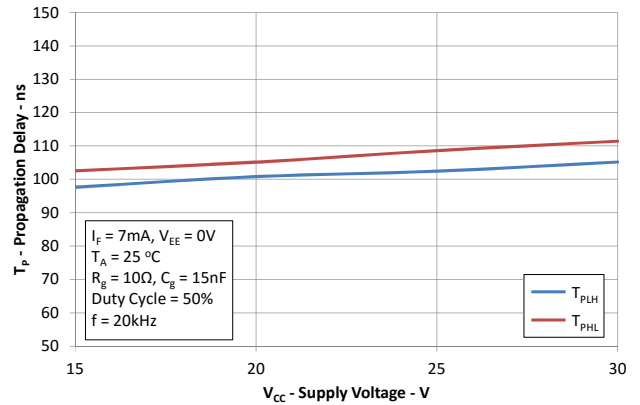

Figure 8: Propagation Delays vs. V_{CC}

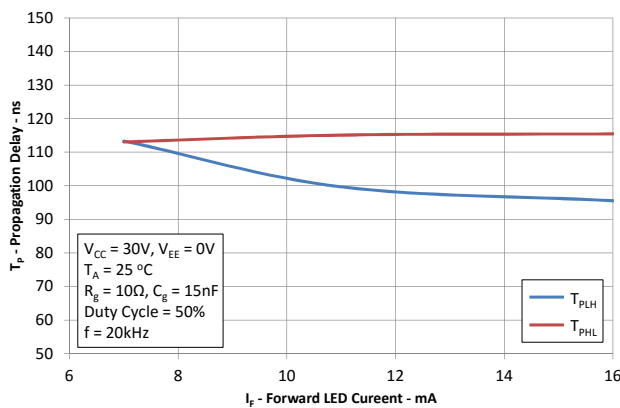

Figure 9: Propagation Delays vs. I_F

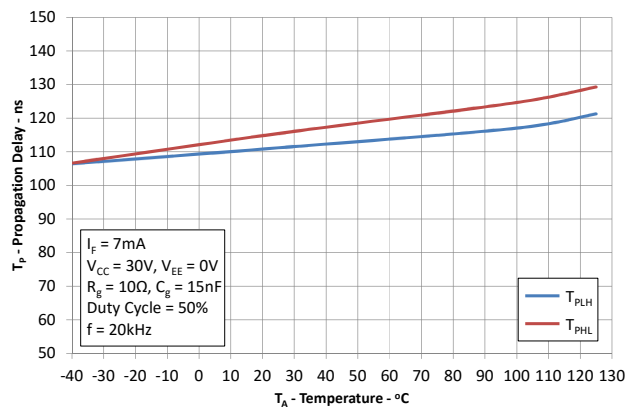

Figure 10: Propagation Delays vs. Temperature

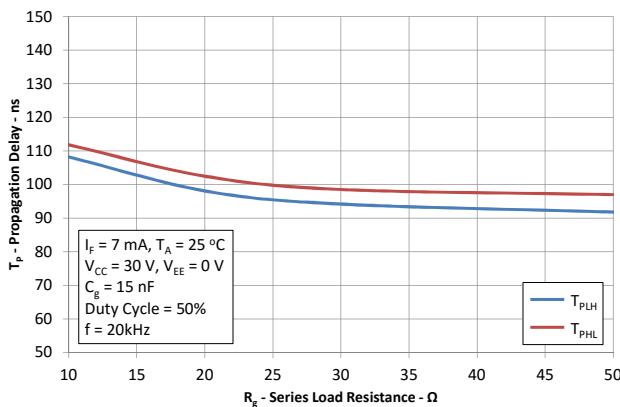

Figure 11: Propagation Delays vs. R_g

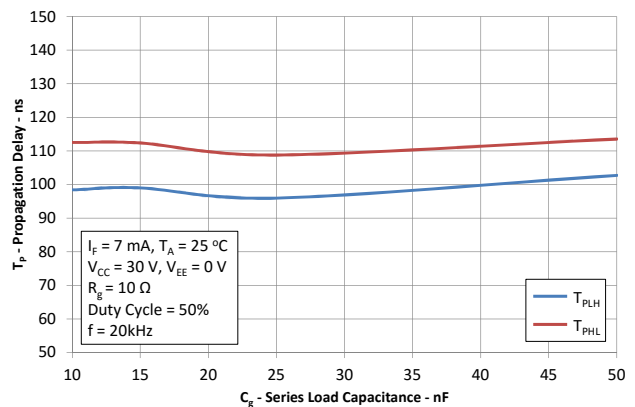

Figure 12: Propagation Delays vs. C_g

Photocoupler LTV-3120-H series

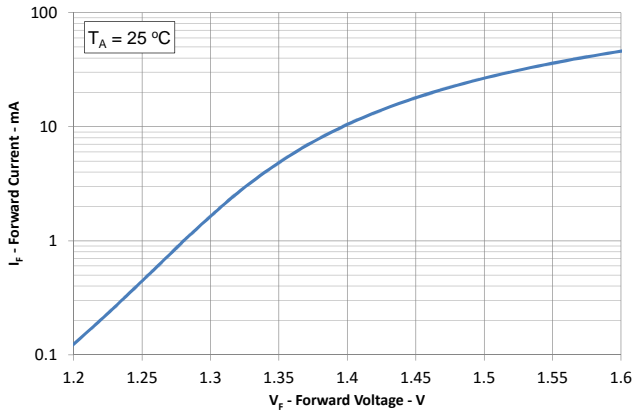

Figure 13: Input Current vs. Forward Voltage

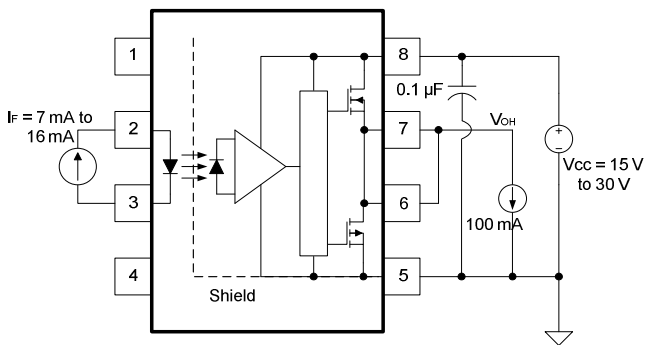

Figure 14 : VOH Test Circuit

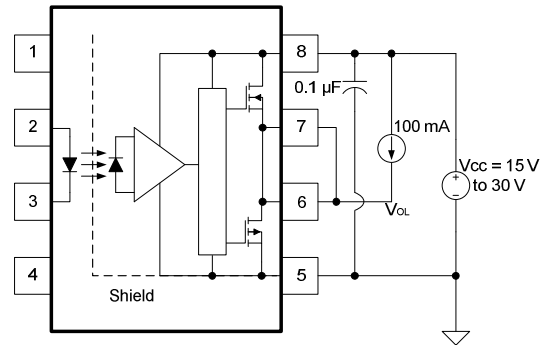

Figure 15 : VOL Test Circuit

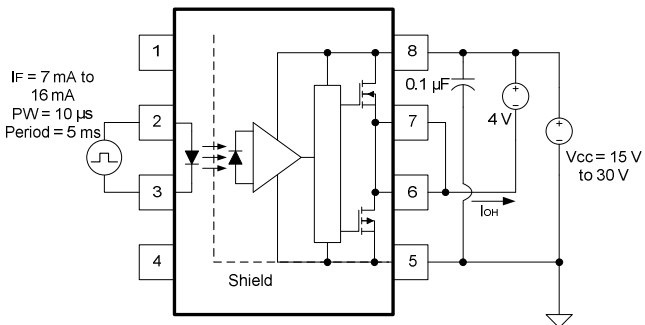

Figure 16 : IOH Test Circuit

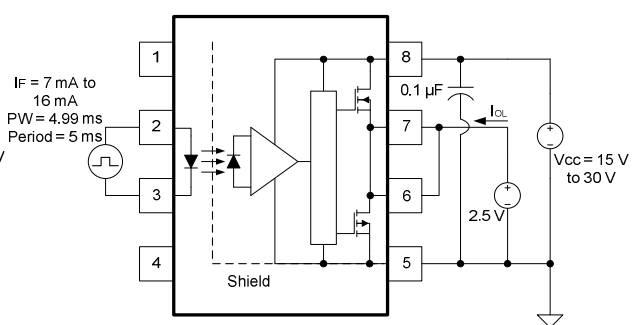

Figure 17 : IOL Test Circuit

Photocoupler LTV-3120-H series

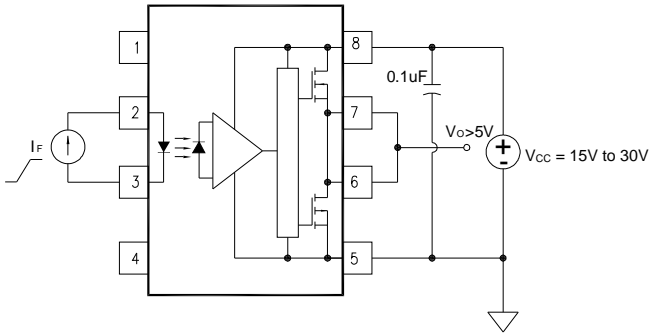

Figure 18 : IFLH Test Circuit

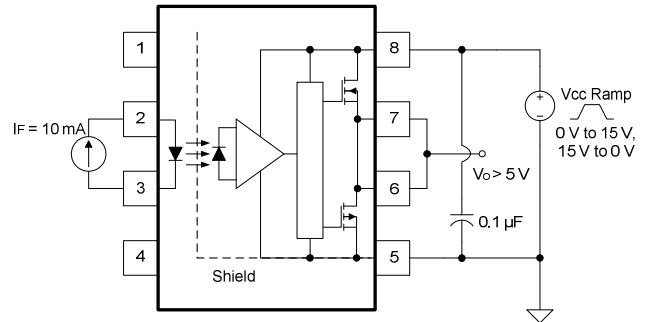

Figure 19 : UVLO Test Circuit

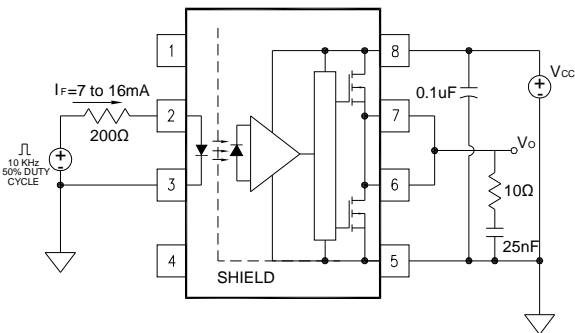

Figure 20 : t_r , t_f , t_{PLH} and t_{PHL} Test Circuit and Waveforms

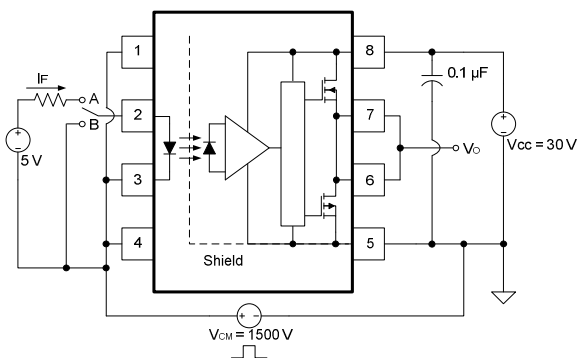
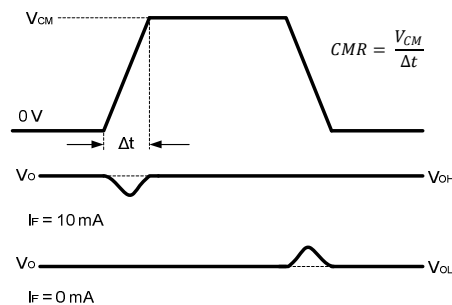
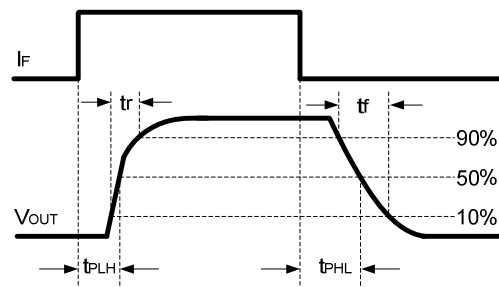

Figure 21 : CMR Test Circuit and Waveforms



Photocoupler LTV-3120-H series

8. TEMPERATURE PROFILE OF SOLDERING

8.1 IR Reflow soldering (JEDEC-STD-020C compliant)

One time soldering reflow is recommended within the condition of temperature and time profile shown below. Do not solder more than three times.

Profile item	Conditions
Preheat	
- Temperature Min (T_{Smin})	150°C
- Temperature Max (T_{Smax})	200°C
- Time (min to max) (ts)	90±30 sec
Soldering zone	
- Temperature (T_L)	217°C
- Time (t_L)	60 ~ 100 sec
Peak Temperature (T_P)	260°C
Ramp-up rate	3°C / sec max.
Ramp-down rate	3~6°C / sec

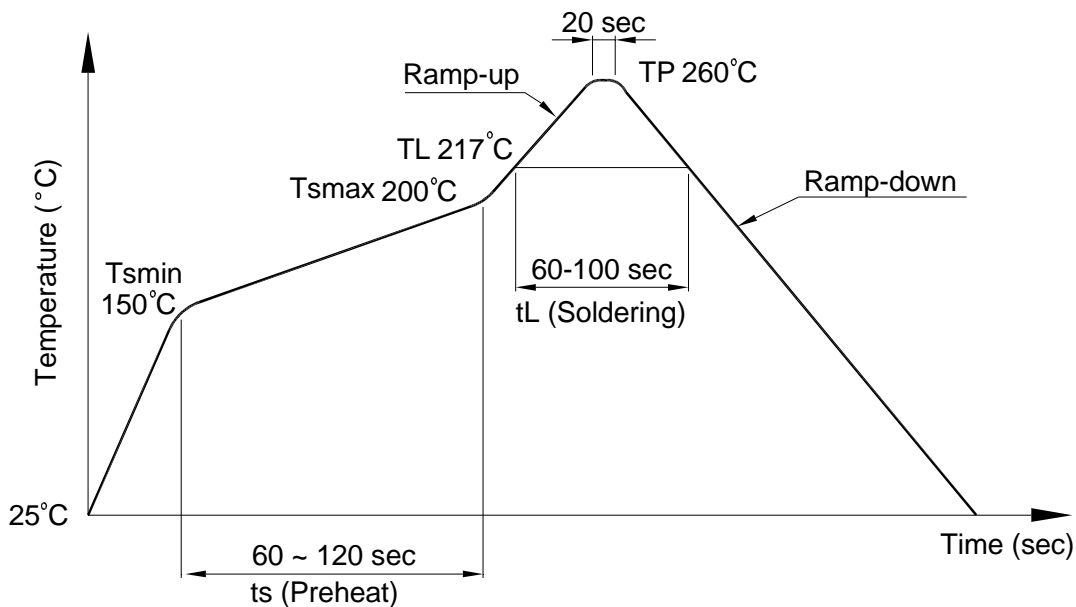

**Photocoupler
LTV-3120-H series**

8.2 Wave soldering (JEDEC22A111 compliant)

One time soldering is recommended within the condition of temperature.

Temperature: $260+0/-5^{\circ}\text{C}$

Time: 10 sec.

Preheat temperature: 25 to 140°C

Preheat time: 30 to 80 sec.

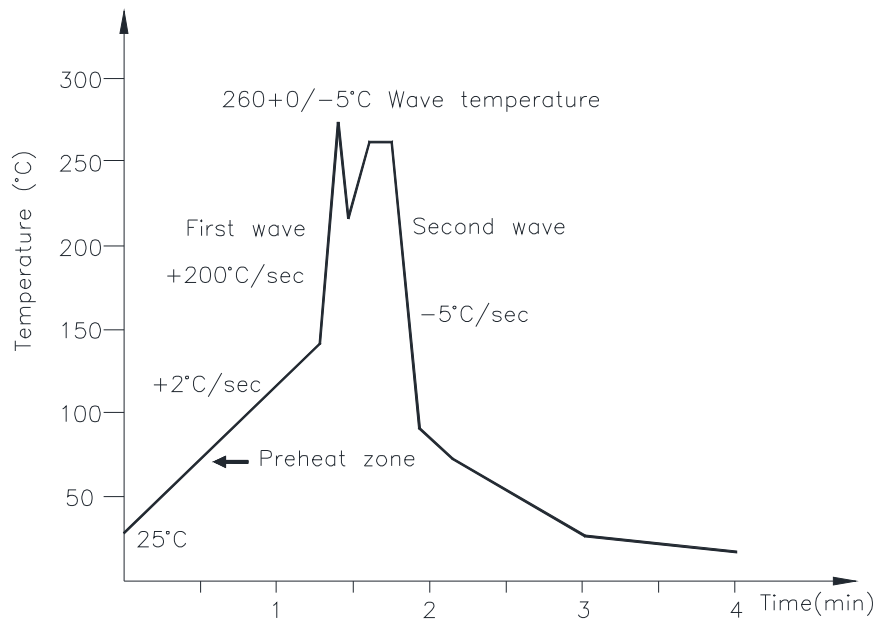

8.3 Hand soldering by soldering iron

Allow single lead soldering in every single process. One time soldering is recommended.

Temperature: $380+0/-5^{\circ}\text{C}$

Time: 3 sec max.

Photocoupler LTV-3120-H series

9. NAMING RULE

Part Number Options	
LTV-3120-H	
LTV-3120M-H	
LTV-3120S-H	
LTV-3120S-TA-H	
LTV-3120S-TA1-H	
LTV3120H-V	
LTV3120MH-V	
LTV3120SH-V	
LTV3120STAH-V	
LTV3120STA1H-V	
Definition of Suffix	Remark
"3120-H"	LiteOn model name
"No Suffix"	Dual-in-Line package clearance distance 7 mm typical
"M"	Wide lead spacing package clearance distance 8 mm typical
"S"	Surface mounting package clearance distance 8 mm typical
"TA"	Pin 1 location at lower right of the tape
"TA1"	Pin 1 location at upper left of the tape
"V"	VDE approved option

10. Notes:

Specifications of the products displayed herein are subject to change without notice.

The products shown in this publication are designed for the general use in electronic applications such as office automation equipment, communications devices, audio/visual equipment, electrical instrumentation and application. For equipment/devices where high reliability or safety is required, such as space applications, nuclear power control equipment, medical equipment, etc, please contact our sales representatives.

X-ON Electronics

Largest Supplier of Electrical and Electronic Components

Click to view similar products for [Logic Output Opto-couplers](#) category:

Click to view products by [Lite-On](#) manufacturer:

Other Similar products are found below :

[CPC1590P](#) [TLP705A\(F\)](#) [VO3120-X019T](#) [TLP5772H\(TP4,E](#) [TLP5772H\(TP,E](#) [TLP5771H\(TP4,E](#) [TLP5771H\(D4,E](#) [TLP5774H\(D4,E](#)
[TLP5771H\(E](#) [TLP5772H\(D4LF4,E](#) [TLP5774H\(LF4,E](#) [TLP5771H\(D4LF4,E](#) [TLP5771H\(LF4,E](#) [TLP5214A\(E\(O](#) [FOD3125SD](#) [FOD8482T](#)
[LTV-3120S-TA1-H](#) [LTV-332J-TP1](#) [PC923LRNIP0F](#) [HCPL-0630-500E\(TOKMAS\)](#) [TLP719F\(D4-TP,F\)](#) [TLP5702\(D4-TP,E\(T](#)
[TLP105\(TPL,F\)](#) [TLP2301\(GB-TPL,E\(T](#) [TLP715\(D4-TP,F\)](#) [TLP2348\(TPL,E\(T](#) [6N137S](#) [KPC410 0E](#) [ELM600\(TA\)](#) [H11L1S\(TA\)](#)
[H11L3SR2M](#) [HCPL-0302-000E](#) [HCPL-J312-000E](#) [LTV-3120S-TA1](#) [TLP155E\(TPL,E\)](#) [TLP2345\(E\(T](#) [TLP2348\(E\(T](#) [TLP350H\(F\)](#)
[TLP5214\(E\(O](#) [TLP701AF\(F\)](#) [5962-89785022A](#) [8302401EC](#) [TLP351H\(F\)](#) [TLP5214\(TP,E\(O](#) [TLP5702\(TP,E](#) [5962-8947701PA](#) [ACPL-W343-](#)
[500E](#) [TLP351H\(TP1,F\)](#) [FOD3120SDV](#) [HCPL-6750](#)