



# Photocopier

## Product Data Sheet

### LTV-4N35/4N37

### (M,S,S-TA,S-TA1)

Spec No.: DS-70-96-0004

Effective Date: 04/19/2000

Revision: D

**LITE-ON DCC**

**RELEASE**

BNS-OD-FC001/A4

## FEATURES

- \* High current transfer ratio  
( CTR : MIN. 100% at  $I_F = 10\text{mA}$ ,  $V_{CE} = 10\text{V}$  )
- \* Response time  
(  $t_{on}$  : TYP.  $3\mu\text{s}$  at  $V_{CC} = 10\text{V}$ ,  $I_C = 2\text{mA}$ ,  $R_L = 100\Omega$  )
- \* Input-output isolation voltage  
LTV-4N35 series :  $V_{iso} = 3,550\text{Vrms}$   
LTV-4N37 series :  $V_{iso} = 1,500\text{Vrms}$
- \* Dual-in-line package :  
LTV-4N35, LTV-4N37
- \* Wide lead spacing package :  
LTV-4N35M, LTV-4N37M
- \* Surface mounting package :  
LTV-4N35S, LTV-4N37S
- \* Tape and reel packaging :  
LTV-4N35S-TA, LTV-4N37S-TA, LTV-4N35S-TA1, LTV-4N37S-TA1
- \* UL approved ( No. E113898 )
- \* TUV approved ( No. R9653630 )
- \* CSA approved ( No. CA91533-1 )
- \* FIMKO approved ( No. 193422-01 )
- \* NEMKO approved ( No. P96103013 )
- \* DEMKO approved ( No. 303985 )
- \* SEMKO approved ( No. 9646047 / 01-30 )
- \* VDE approved ( No. 094722 )

## OUTLINE DIMENSIONS

### LTV-4N35 :

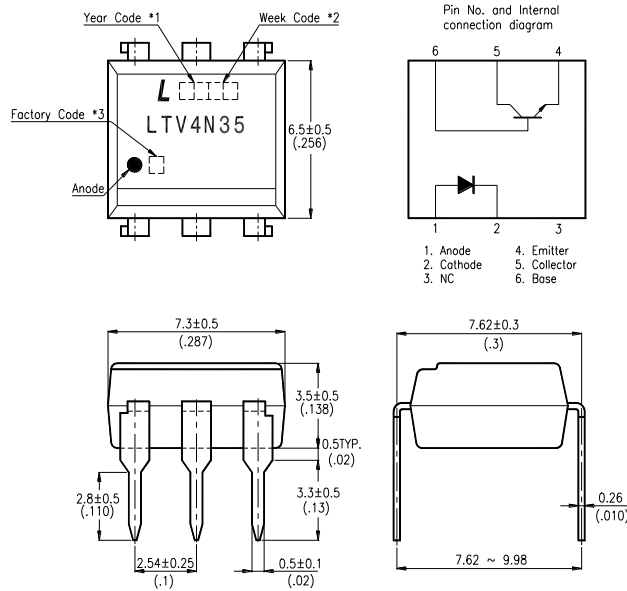

### LTV-4N37 :

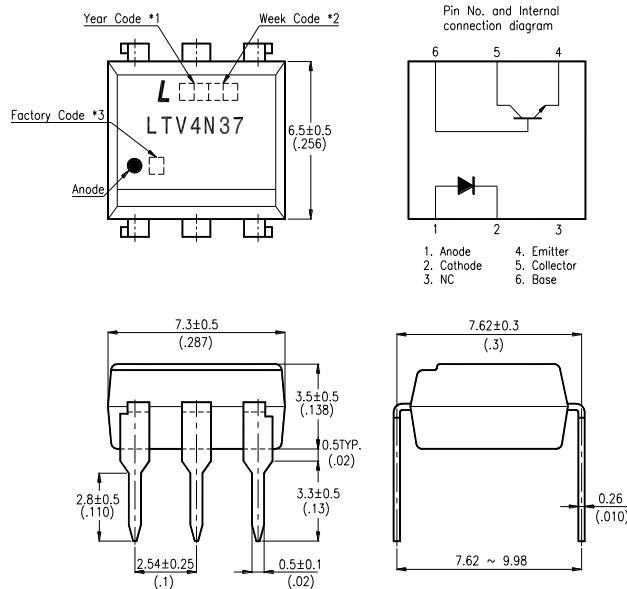

- \*1. Year date code.
- \*2. 2-digit work week.
- \*3. Factory identification mark shall be marked (Z : Taiwan, Y : Thailand).

## OUTLINE DIMENSIONS

### LTV-4N35M :

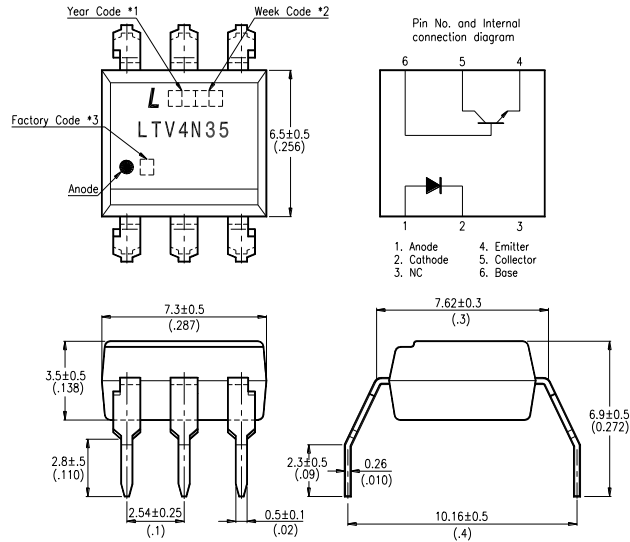

### LTV-4N37M :

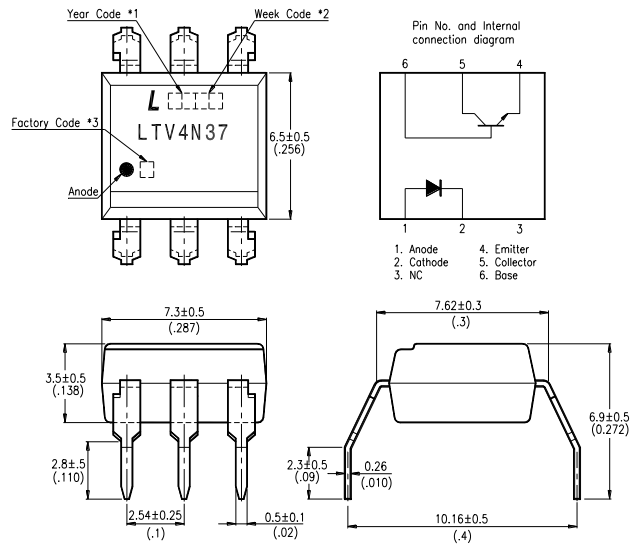

\*1. Year date code.

\*2. 2-digit work week.

\*3. Factory identification mark shall be marked (Z : Taiwan, Y : Thailand).

### OUTLINE DIMENSIONS

#### LTV-4N35S :

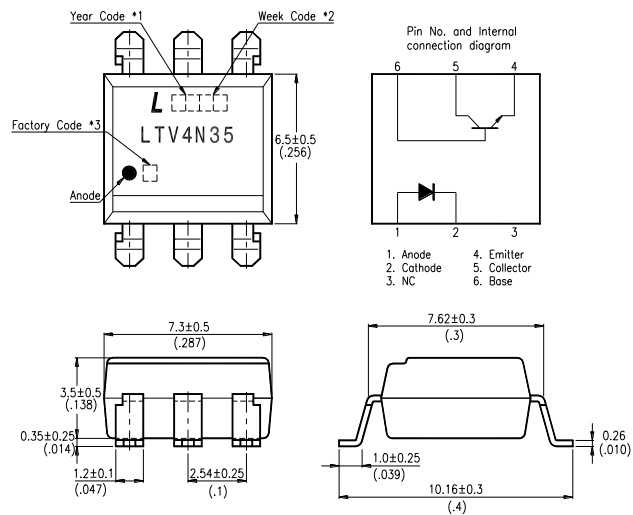

#### LTV-4N37S :

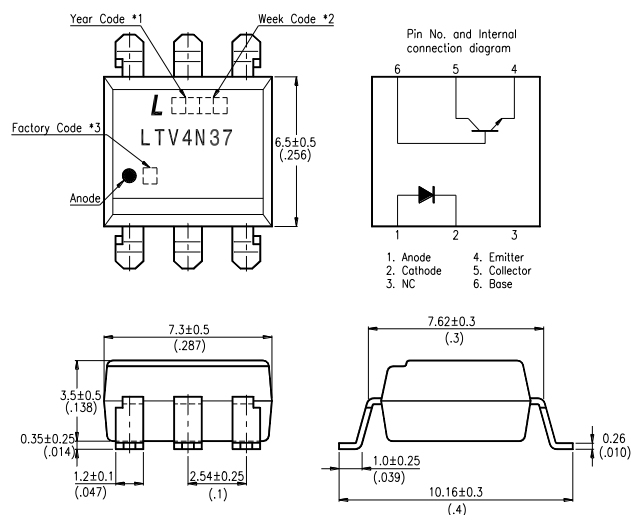

- \*1. Year date code.
- \*2. 2-digit work week.
- \*3. Factory identification mark shall be marked (Z : Taiwan, Y : Thailand).

## TAPING DIMENSIONS

**LTV-4N35S-TA , LTV-4N37S-TA :**

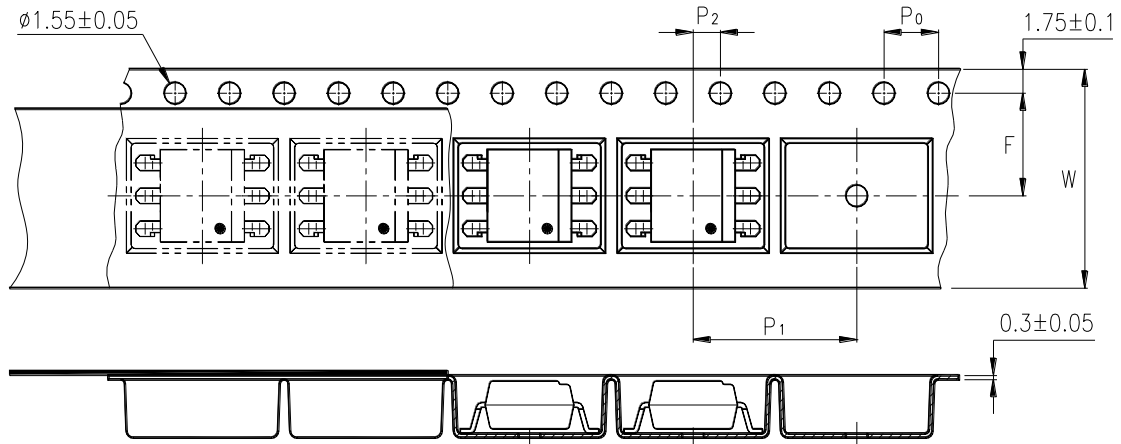

**LTV-4N35S-TA1 , LTV-4N37S-TA1 :**

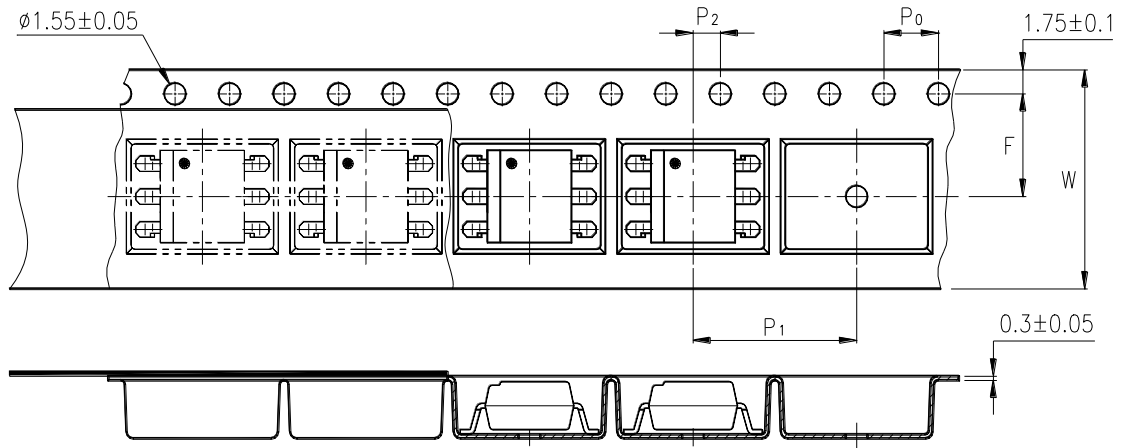

Description	Symbol	Dimensions in mm ( inches )
Tape wide	W	$16 \pm 0.3$ ( .63 )
Pitch of sprocket holes	$P_0$	$4 \pm 0.1$ ( .15 )
Distance of compartment	F	$7.5 \pm 0.1$ ( .295 )
Distance of compartment to compartment	$P_2$	$2 \pm 0.1$ ( .079 )
Distance of compartment to compartment	$P_1$	$12 \pm 0.1$ ( .472 )

### ABSOLUTE MAXIMUM RATING

( Ta = 25°C )

PARAMETER		SYMBOL	RATING	UNIT
INPUT	Forward Current	I <sub>F</sub>	60	mA
	Reverse Voltage	V <sub>R</sub>	6	V
	Power Dissipation	P	100	mW
OUTPUT	Collector - Emitter Voltage	V <sub>CEO</sub>	30	V
	Emitter - Collector Voltage	V <sub>ECO</sub>	7	V
	Collector - Base Voltage	V <sub>CBO</sub>	70	V
	Collector Current	I <sub>C</sub>	100	mA
	Collector Power Dissipation	P <sub>C</sub>	300	mW
Total Power Dissipation		P <sub>tot</sub>	350	mW
*1 Isolation Voltage	LTV-4N35 series	V <sub>iso</sub>	3,550	V <sub>rms</sub>
	LTV-4N37 series		1,500	
Operating Temperature		T <sub>opr</sub>	-55 ~ +100	°C
Storage Temperature		T <sub>stg</sub>	-55 ~ +150	°C
*2 Soldering Temperature		T <sub>sol</sub>	260	°C

\*1. AC For 1 Minute, R.H. = 40 ~ 60%

Isolation voltage shall be measured using the following method.

- (1) Short between anode and cathode on the primary side and between collector, emitter and base on the secondary side.
- (2) The isolation voltage tester with zero-cross circuit shall be used.
- (3) The waveform of applied voltage shall be a sine wave.

\*2. For 10 Seconds

### ELECTRICAL - OPTICAL CHARACTERISTICS

( Ta = 25°C )

PARAMETER		SYMBOL	MIN.	TYP.	MAX.	UNIT	CONDITIONS	
INPUT	Forward Voltage	$V_F$	—	1.2	1.5	V	$I_F=10\text{mA}$	
	Reverse Current	$I_R$	—	—	10	$\mu\text{A}$	$V_R=4\text{V}$	
	Terminal Capacitance	$C_t$	—	50	—	pF	$V=0, f=1\text{KHz}$	
OUTPUT	Collector Dark Current	$I_{CEO}$	Ta=25°C	—	—	50	nA	$V_{CE}=10\text{V}, I_F=0$
			Ta=100°C	—	—	500	$\mu\text{A}$	$V_{CE}=30\text{V}, I_F=0$
	Collector-Emitter Breakdown Voltage	$BV_{CEO}$	30	—	—	V	$I_C=0.1\text{mA}$ $I_F=0$	
	Emitter-Collector Breakdown Voltage	$BV_{ECO}$	7	—	—	V	$I_E=10\mu\text{A}$ $I_F=0$	
	Collector-Base Breakdown Voltage	$BV_{CBO}$	70	—	—	V	$I_C=0.1\text{mA}$ $I_F=0$	
TRANSFER CHARACTERISTICS	Collector Current	$I_C$	10	—	—	mA	$I_F=10\text{mA}$ $V_{CE}=10\text{V}$	
	* Current Transfer Ratio	CTR	100	—	—	%		
	Collector-Emitter Saturation Voltage	$V_{CE(sat)}$	—	—	0.3	V	$I_F=50\text{mA}$ $I_C=2\text{mA}$	
	Isolation Resistance	$R_{iso}$	$5 \times 10^{10}$	$1 \times 10^{11}$	—	$\Omega$	DC500V 40 ~ 60% R.H.	
	Floating Capacitance	$C_f$	—	1	2.5	pF	$V=0, f=1\text{MHz}$	
	Response Time (Turn-on)	$t_{on}$	—	3	10	$\mu\text{s}$	$V_{CC}=10\text{V}, I_C=2\text{mA}$ $R_L=100\Omega$	
	Response Time (Turn-off)	$t_{off}$	—	3	10	$\mu\text{s}$		

$$* \text{ CTR} = \frac{I_C}{I_F} \times 100\%$$



## CHARACTERISTICS CURVES

Fig.1 Forward Current vs. Ambient Temperature

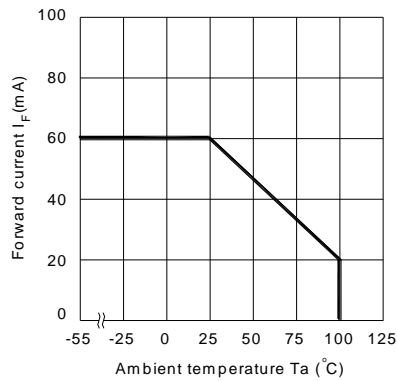

Fig.2 Collector Power Dissipation vs. Ambient Temperature

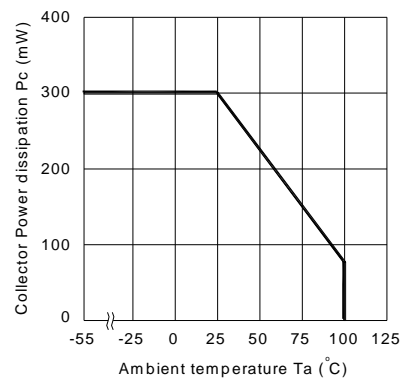

Fig.3 Forward Current vs. Forward Voltage

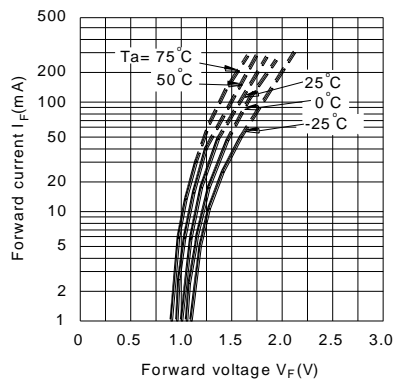

Fig.4 Current Transfer Ratio vs. Forward Current

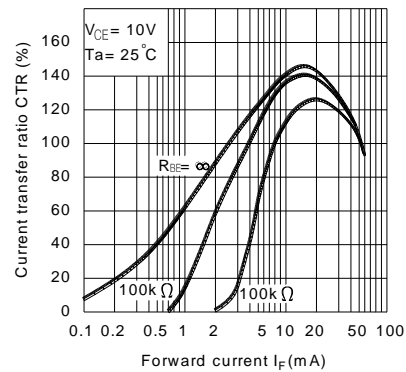

Fig.5 Collector Current vs. Collector-emitter Voltage

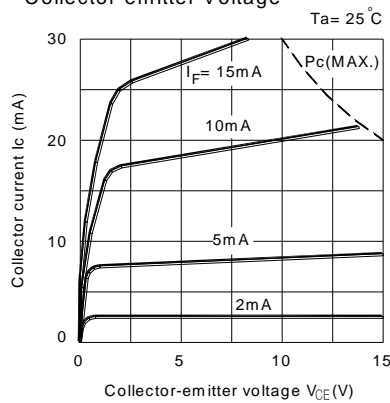
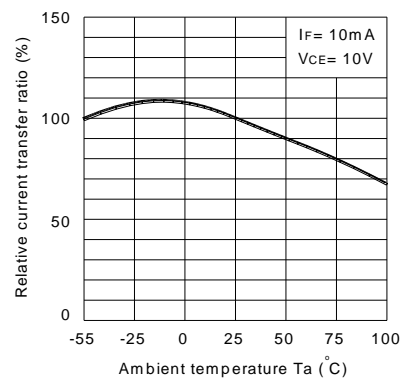

Fig.6 Relative Current Transfer Ratio vs. Ambient Temperature



### CHARACTERISTICS CURVES

Fig.7 Collector-emitter Saturation Voltage vs. Ambient Temperature

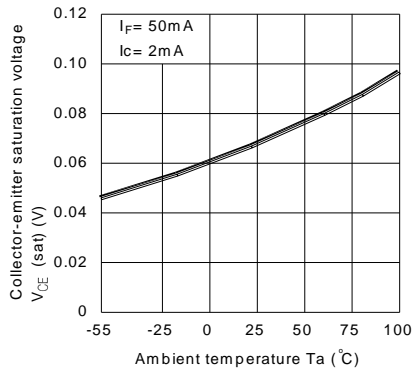

Fig.8 Collector Dark Current vs. Ambient Temperature

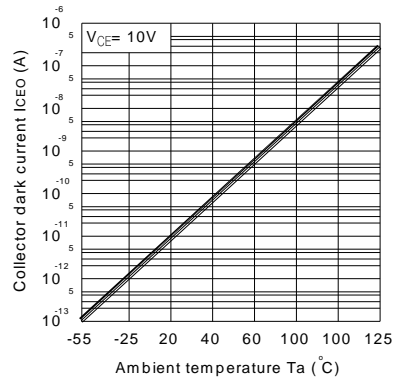

Fig.9 Response Time vs. Load Resistance

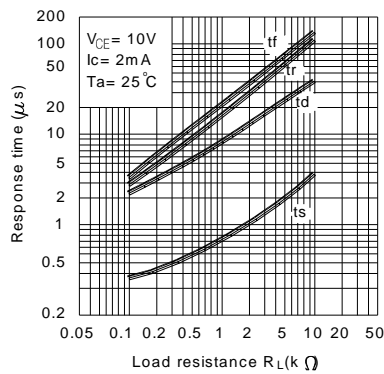

Fig.10 Frequency Response

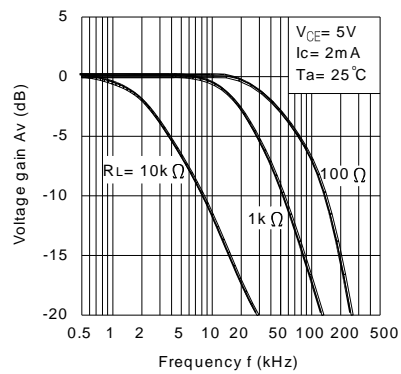
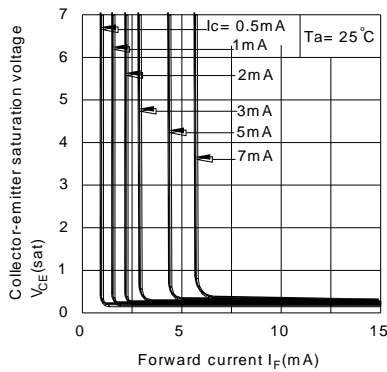
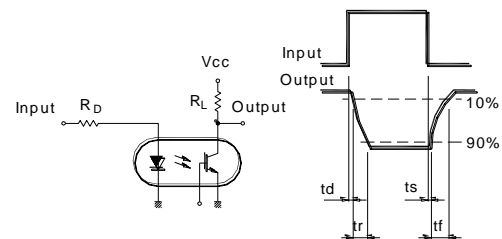

Fig.11 Collector-emitter Saturation Voltage vs. Forward Current



Test Circuit for Response Time



Test Circuit for Frequency Response

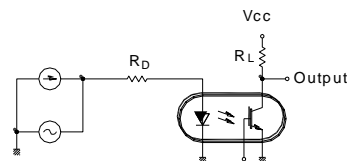

## X-ON Electronics

Largest Supplier of Electrical and Electronic Components

*Click to view similar products for [High Speed Optocouplers](#) category:*

*Click to view products by [Lite-On](#) manufacturer:*

Other Similar products are found below :

[6N136F](#) [PS8502L2-AX](#) [ACNW261L-000E](#) [ACPL-344JT-000E](#) [ACPL-K49T-500E](#) [ACPL-K74T-000E](#) [ACPL-K75T-000E](#) [ACPL-W21L-560E](#) [AQH3213J](#) [ACPL-K44T-500E](#) [TLP187\(TPL,E\(T](#) [TLP2601\(TP1,F\)](#) [610737H](#) [6N137A-X001](#) [6N137A-X017T](#) [6N139-X007T](#) [HCPL2630M](#) [HCPL2731SM](#) [TLP555\(F\)](#) [HCPL2630SM](#) [PS2841-4A-F3-AX](#) [PS9817A-1-F3-AX](#) [PS9821-2-F3-AX](#) [ORPC-817D](#) [ORPC-817M/C](#) [ORPC-817M/B](#) [PT17-51C/L129\(BIN2\)](#) [TLP521-4GBSM](#) [UMW817C](#) [6N137S1\(TA\)](#) [TLP521GB](#) [TLP521GB-S](#) [PS2501](#) [PS2501-S](#) [TLP785GB](#) [TLP785GB-S](#) [LTV-214-G](#) [TLP2766A\(E](#) [TLP2766A\(LF4,E](#) [LCR-0202](#) [EL814S1\(TA\)-V](#) [PC817X4NSZ2B](#) [OR-MOC3023](#) [TLP267J\(TPL,E\(T](#) [TLP109\(TPL,E\(O](#) [EL2514S1\(TU\)\(CLW\)-G](#) [EL817S1\(C\)\(TU\)-G](#) [EL816S2\(C\)\(TU\)-F](#) [TLP281-4](#) [MOC3023M](#)