

SMD LAMP LEDOFFICE : 90 Chien I Road, Chung Ho
Taipei, Taiwan, R.O.C.

TEL : +886-2-2222-6181

FAX : +886-2-2226-5872

LTW-3528VSY-32**DATASHEET**

(Preliminary)

DATE : 2013/10/11

REV. NO. : Version : -

PAGE : 0 of 11

Property of Lite-On Only

Features

- * Package in 8mm tape on 7" diameter reels.
- * Compatible with automatic placement equipment.
- * Compatible with infrared and vapor phase reflow solder process.
- * EIA STD package.
- * I.C. compatible.
- * Meet green product and Pb-free(According to RoHS)

Package Dimensions

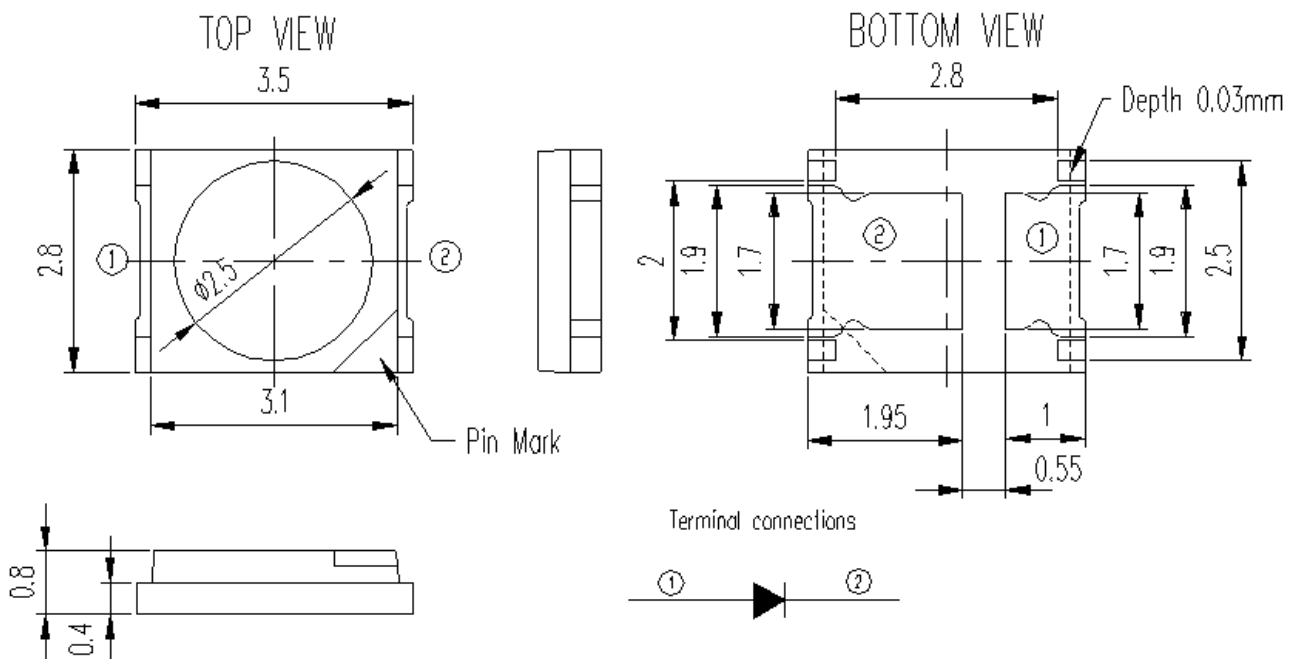

Part No.	Phosphor	Source Color
LTW-3528VSY-32	Yellow	InGaN Blue

Notes:

1. All dimensions are in millimeters.
2. Tolerance is ± 0.2 mm (.008") unless otherwise noted.

Property of Lite-On Only

Absolute Maximum Ratings at Ta=25°C

Parameter	Symbol	Rating	Unit
Forward Current	If	350	mA
Power Consumption	Pd	900	mW
Operating Temp	Topr	-40~80	°C
Storage Temp	Tstg	-40~100	°C
Storage Humidity	Hstg	10~90	%RH
Reverse Voltage *1	Vr	5	V

Note:

Operating the LED (in an application) under reverse bias condition might result in damage or failure of the component.

(PCT reflow max temp. should be lower than 240°C)↯

Suggestion IR Reflow Profile For Pb Free Process :↯

IR-Reflow Soldering Profile for lead free soldering (Acc. to J-STD-020D)↯

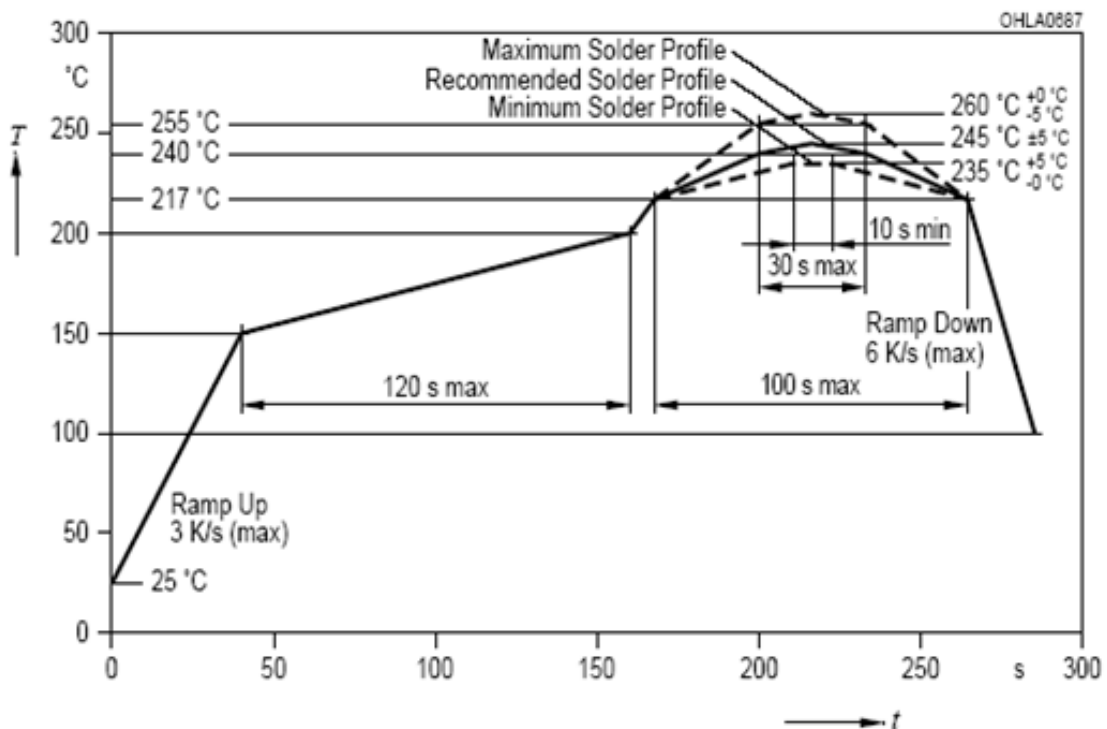

Property of Lite-On Only

Electro-Optical Characteristics at Ta=25°C

Parameter	Symbol	Values		Test Condition	Unit
Forward Voltage of dual chips in series	V_F	Min.	2.8	$I_F = 330\text{mA}$	V
		Typ.	3.3		
		Max.	3.6		
Luminous Flux ¹	Φ_V	Min.	105	$I_F = 330\text{mA}$	lm
		Typ.	110		
		Max	125		
Viewing Angle	$2\theta_{1/2}$	Typ.	120	$I_F = 330\text{mA}$	°
Chromaticity Coordinates	x	Typ.	0.265	$I_F = 330\text{mA}$	
	y	Typ.	0.235		

Notes

- Luminous flux is the total luminous flux output as measured with an integrating sphere.
- Iv classification code is marked on each packing bag.
- The chromaticity coordinates (x, y) is derived from the 1931 CIE chromaticity diagram.
- Caution in ESD:
Static Electricity and surge damages the LED. It is recommended using a wrist band or anti-electrostatic glove when handling the LED. All devices, equipment and machinery must be properly grounded.
- CAS140B is the test standard for the chromaticity coordinates (x, y) & Φ_V .
- The chromaticity coordinates (x, y) guarantee should be added +/- 0.01 tolerance

Property of Lite-On Only

Bin Code List

V _F Spec. Table		
V _F Bin	Forward Voltage (volts) at I _F = 330mA	
	Min.	Max.
V1	2.8	3.0
V2	3.0	3.2
V3	3.2	3.4
V4	3.4	3.6

Tolerance on each Forward Voltage bin is +/- 0.1 V

Φ _v Luminous Flux Spec. Table		
Φ _v Bin	Φ _v (lm) at I _F = 330mA	
	Min.	Max.
T	80	85
U	85	90
V	90	95
W	95	100
X	100	105
Y	105	110
Z	110	115
A	115	120
B	120	125

Tolerance on each Luminous Flux bin is +/- 10%.

W _p Spec table		
W _p Bin	Peak Wavelength (nm) at I _F = 330mA	
	Min.	Max.
P1	433	442
P2	442	451

Tolerance on each Peak Wavelength bin is +/- 1nm

Property of Lite-On Only

Hue Spec. Table					
Hue Bin	Color bin limits at If = 330mA				
	CIE 1931 Chromaticity coordinates				
B20	x	0.2515	0.2466	0.2586	0.2635
	y	0.2200	0.2100	0.2100	0.2200
B21	x	0.2565	0.2515	0.2635	0.2685
	y	0.2300	0.2200	0.2200	0.2300
B22	x	0.2614	0.2565	0.2685	0.2734
	y	0.2400	0.2300	0.2300	0.2400
B23	x	0.2663	0.2614	0.2734	0.2783
	y	0.2500	0.2400	0.2400	0.2500
B24	x	0.2712	0.2663	0.2783	0.2832
	y	0.2600	0.2500	0.2500	0.2600
B25	x	0.2761	0.2712	0.2832	0.2881
	y	0.2700	0.2600	0.2600	0.2700
B26	x	0.2810	0.2761	0.2881	0.2930
	y	0.2800	0.2700	0.2700	0.2800

Tolerance on each Hue (x, y) bin is +/- 0.01

Hue Bin

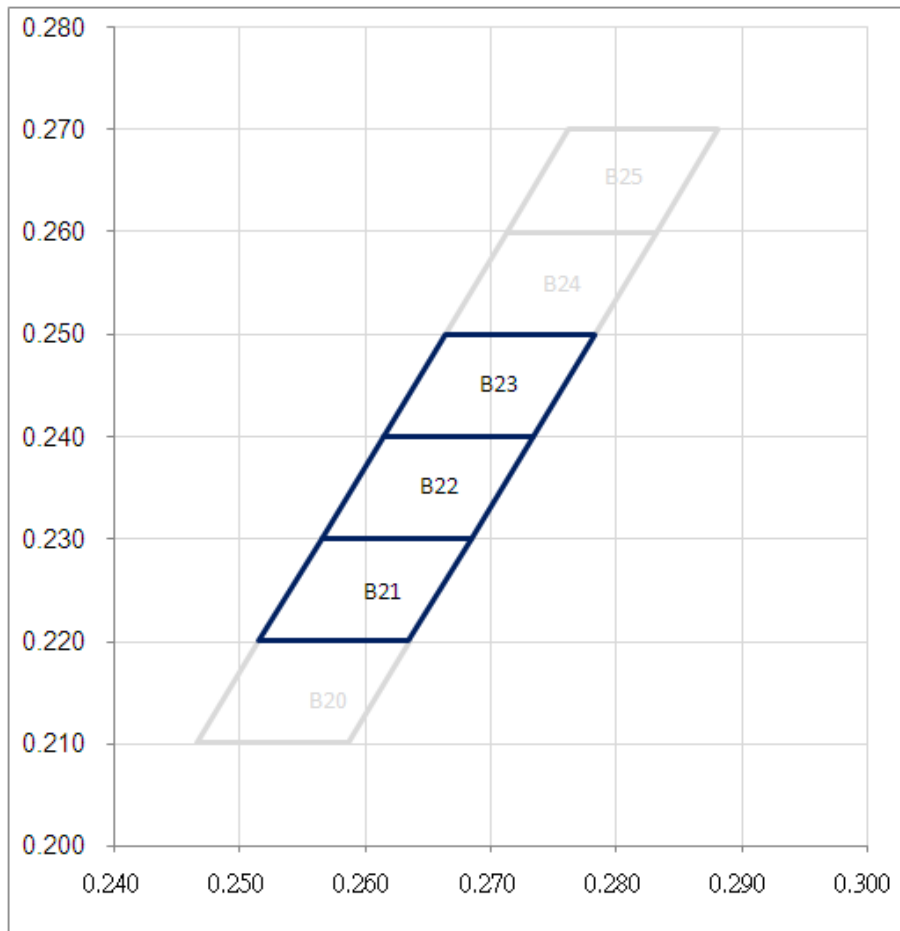

Property of Lite-On Only

Typical Electrical / Optical Characteristics Curves (25°C Ambient Temperature Unless Otherwise Noted)

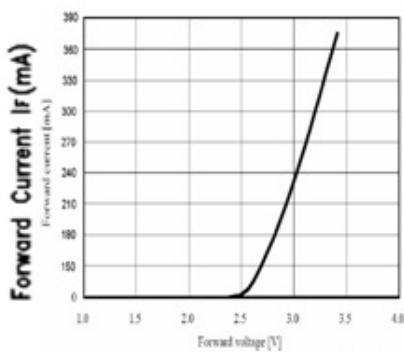
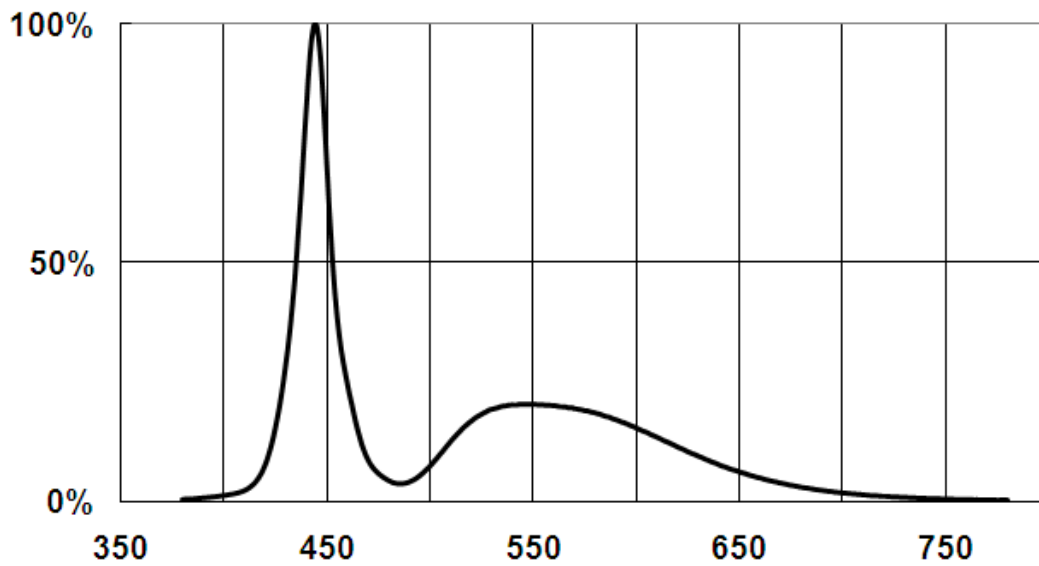

Forward Voltage V_F (V)
Fig.2 Forward Current vs. Forward Voltage

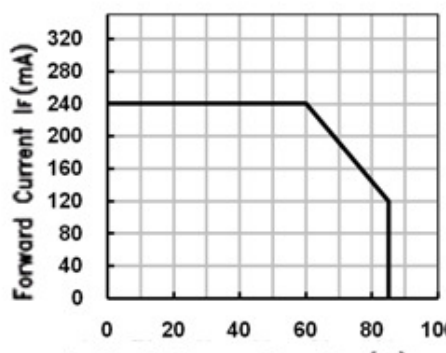

Ambient Temperature T_A (°C)
Fig.3 Forward Current Derating Curve

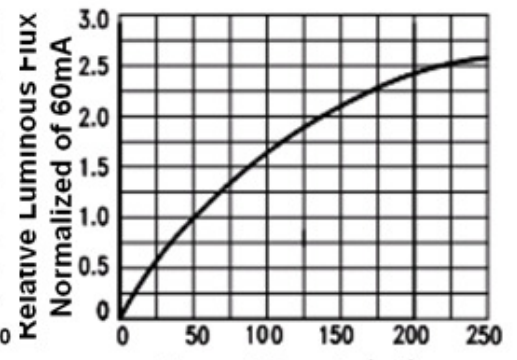

Fig.4 Relative Luminous Intensity vs. Forward Current

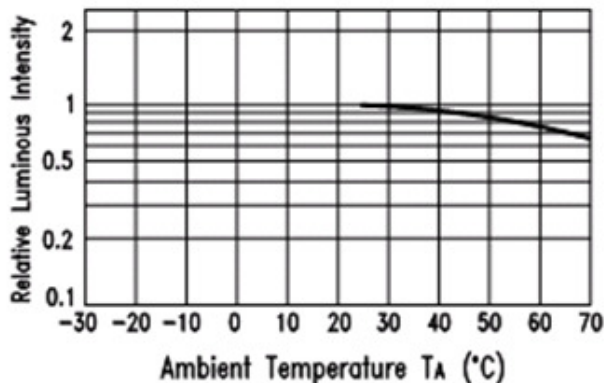

Fig.5 Luminous Intensity vs. Ambient Temperature

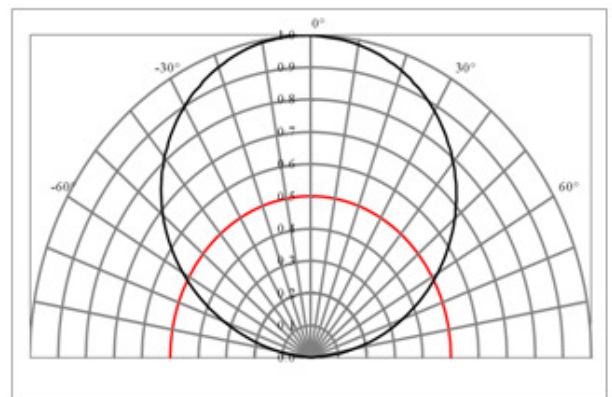

Fig.6 Spatial Distribution

Property of Lite-On Only

User Guide

Cleaning

Do not use unspecified chemical liquid to clean LED they could harm the package.

If cleaning is necessary, immerse the LED in ethyl alcohol or isopropyl alcohol at normal temperature for less than one minute.

Recommend Printed Circuit Board Attachment Pad

Infrared / vapor phase

Reflow Soldering

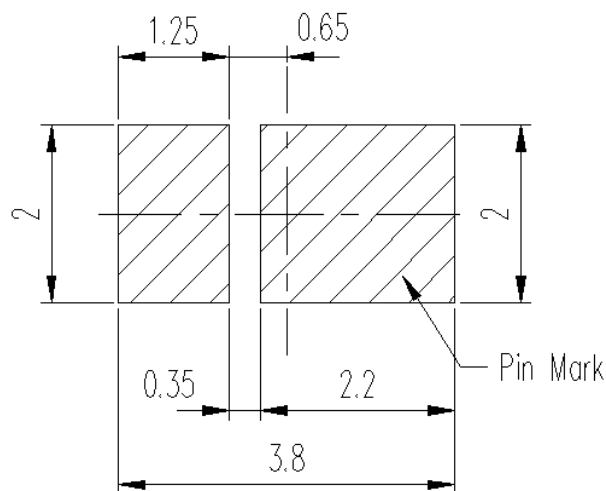

Package Dimensions of Tape

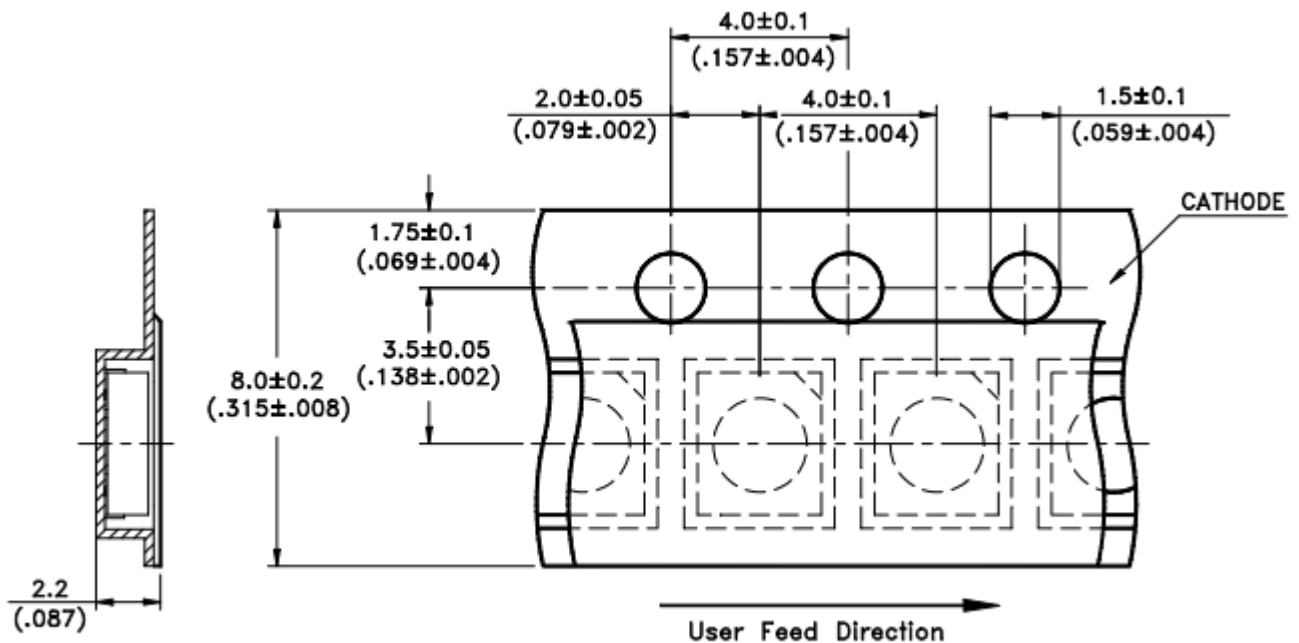

Note:

1. All dimensions are in millimeters (inches).

Package Dimensions of Reel

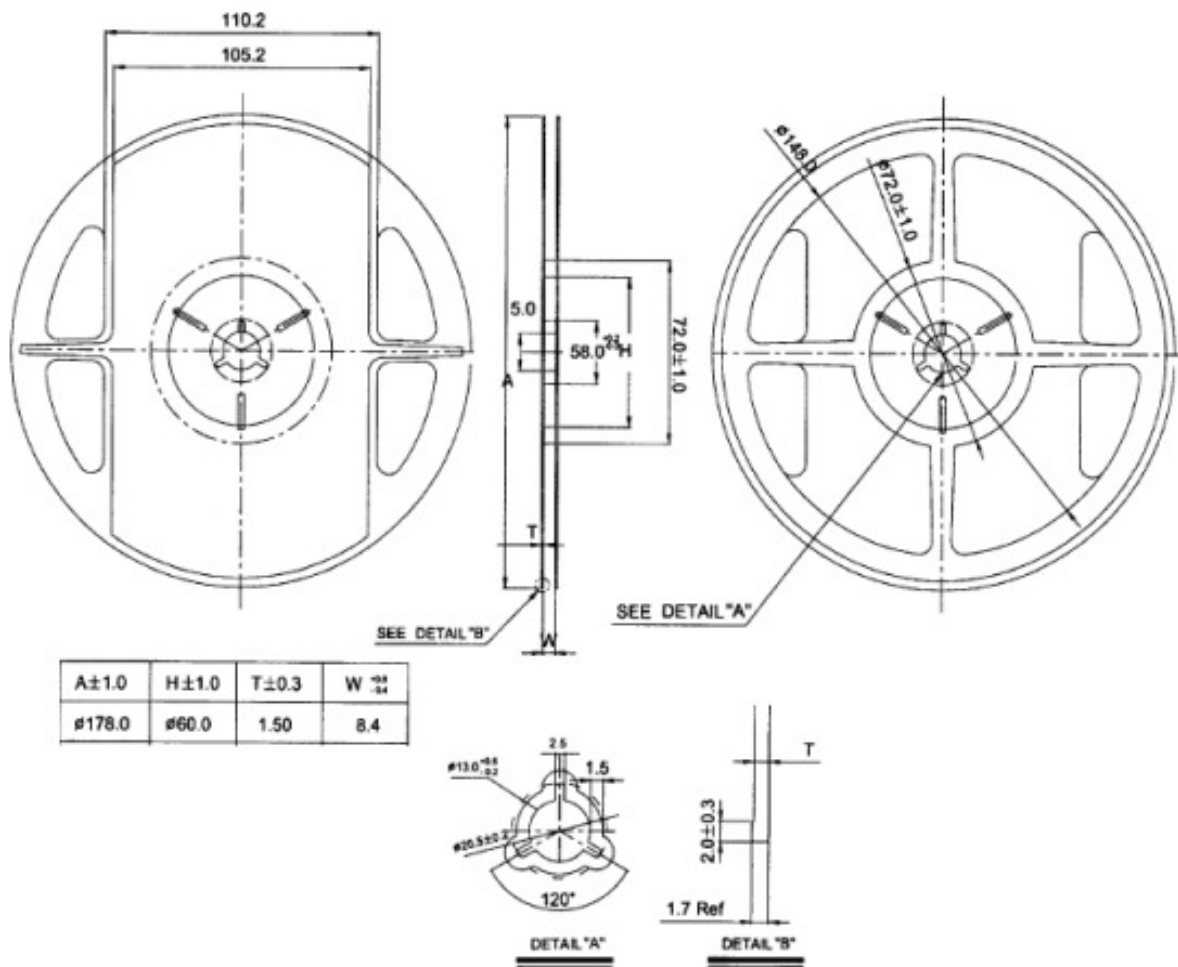

Notes:

1. Empty component pockets sealed with top cover tape.
2. 7 inch reel- maximum 2000 pieces per reel.
3. Minimum packing quantity is 500 pieces for remainders.
4. The maximum number of consecutive missing lamps is two.
5. In accordance with EIA-481-1-B specifications.

CAUTIONS

1. Application

The LEDs described here are intended to be used for ordinary electronic equipment (such as office equipment, communication equipment and household applications). Consult Liteon's Sales in advance for information on applications in which exceptional reliability is required, particularly when the failure or malfunction of the LEDs may directly jeopardize life or health (such as in aviation, transportation, traffic control equipment, medical and life support systems and safety devices).

2. Storage

This product is qualified as Moisture sensitive Level 4 per JEDEC J-STD-020 Precaution when handling this moisture sensitive product is important to ensure the reliability of the product.

The package is sealed:

The LEDs should be stored at 30°C or less and 90%RH or less. And the LEDs are limited to use within one year, while the LEDs is packed in moisture-proof package with the desiccants inside.

The package is opened:

The LEDs should be stored at 30°C or less and 60%RH or less. Moreover, the LEDs are limited to solder process within 72hrs. If the Humidity Indicator shows the pink color in 10% even higher or exceed the storage limiting time since opened, that we recommended to baking LEDs at 60°C at least 48hrs. To seal the remainder LEDs return to package, it's recommended to be with workable desiccants in original package.

3. Cleaning

Use alcohol-based cleaning solvents such as isopropyl alcohol to clean the LED if necessary.

4. Soldering

Recommended soldering conditions:

Reflow soldering		Wave Soldering		Soldering iron	
Pre-heat	120~150°C	Pre-heat	100°C Max.	Temperature	300°C Max.
Pre-heat time	120 sec. Max.	Pre-heat time	60 sec. Max.	Soldering time	3 sec. Max.
Soldering Temp.	260°C Max.	Solder wave	260°C Max.		(one time only)
Soldering time	30 sec. Max.	Soldering time	10 sec. Max.		

5. Drive Method

An LED is a current-operated device. In order to ensure intensity uniformity on multiple LEDs connected in parallel in an application, it is recommended that a current limiting resistor be incorporated in the drive circuit, in series with each LED as shown in Circuit A below.

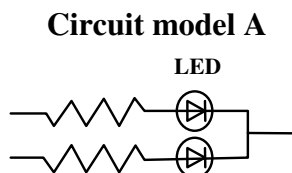

(A) Recommended circuit.

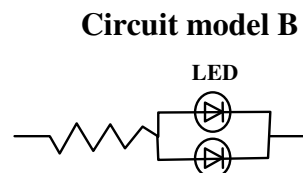

(B) The brightness of each LED might appear different due to the differences in the I-V characteristics of those LEDs.

6. ESD (Electrostatic Discharge)

Static Electricity or power surge will damage the LED.

Suggestions to prevent ESD damage:

Property of Lite-On Only

- Use of a conductive wrist band or anti-electrostatic glove when handling these LEDs.
- All devices, equipment, and machinery must be properly grounded.
- Work tables, storage racks, etc. should be properly grounded.
- Use ion blower to neutralize the static charge which might have built up on surface of the LED's plastic lens as a result of friction between LEDs during storage and handling.

ESD-damaged LEDs will exhibit abnormal characteristics such as high reverse leakage current, low forward voltage, or “no lightup” at low currents.

To verify for ESD damage, check for “light up” and Vf of the suspect LEDs at low currents.

The Vf of “good” LEDs should be >2.0V@0.1mA for InGaN product and >1.4V@0.1mA for AlInGaP product.

7. Reliability Test

No	Items[1]	Temp. (°C)	Humidity (%)	Other condition	Test period	Spec	Number Damaged
1	Room temp driving	25	-----	If = 330mA	1000hrs	IV decay < 70%	0/30
2	Operating driving	60	-----	If = 330mA	1000hrs	Δ VF < 0.3V	0/30
3	Low temp driving	-30	-----	If = 330mA	1000hrs	ΔCx, ΔCy < ±0.03	0/30
4	Thermal shock	-----	-----	H: +100°C 20min L: -40°C 20min (Trans Time : 20sec)	100 cycles	No lighting problem (Abnormal phenomenon)	0/30

Property of Lite-On Only**8. Others**

The appearance and specifications of the product may be modified for improvement without prior notice.

9. Suggested Checking List

Training and Certification

1. Everyone working in a static-safe area is ESD-certified?
2. Training records kept and re-certification dates monitored?

Static-Safe Workstation & Work Areas

1. Static-safe workstation or work-areas have ESD signs?
2. All surfaces and objects at all static-safe workstation and within 1 ft measure less than 100V?
3. All ionizer activated, positioned towards the units?
4. Each work surface mats grounding is good?

Personnel Grounding

1. Every person (including visitors) handling ESD sensitive (ESDS) items wear wrist strap, heel strap or conductive shoes with conductive flooring?
2. If conductive footwear used, conductive flooring also present where operator stand or walk?
3. Garments, hairs or anything closer than 1 ft to ESD items measure less than 100V*?
4. Every wrist strap or heel strap/conductive shoes checked daily and result recorded for all DLs?
5. All wrist strap or heel strap checkers calibration up to date?

Note: *50V for Blue LED.

Device Handling

1. Every ESDS items identified by EIA-471 labels on item or packaging?
2. All ESDS items completely inside properly closed static-shielding containers when not at static-safe workstation?
3. No static charge generators (e.g. plastics) inside shielding containers with ESDS items?
4. All flexible conductive and dissipative package materials inspected before reuse or recycle?

Others

1. Audit result reported to entity ESD control coordinator?
2. Corrective action from previous audits completed?
3. Are audit records complete and on file?

X-ON Electronics

Largest Supplier of Electrical and Electronic Components

Click to view similar products for [Standard LEDs - SMD category](#):

Click to view products by [Lite-On manufacturer](#):

Other Similar products are found below :

[LTST-C190KYKT](#) [LTST-C19GD2WT](#) [LTST-N683GBEW](#) [LTW-170ZDC](#) [LTW-M140SZS40](#) [598-8110-100F](#) [598-8170-100F](#) [598-8610-202F](#) [91-21SURC/S530-A3/TR10](#) [AAAF5060QBFSEEZGS](#) [ALMD-LB36-SV002](#) [APT1608QGW](#) [EAST2012YA0](#) [EASV1803BA0](#) [91-21UYC/S530-A3/TR10](#) [LG M67K-H1J2-24-0-2-R18-Z](#) [SML-512VWT86A](#) [SML-LX0606SISUGC/A](#) [SML-LXL1307SRC-TR](#) [SML-LXR851SIUPGUBC](#) [LT1ED53A](#) [AM27ZGC03](#) [APB3025SGNC](#) [APFA3010SURKCGKQBDC](#) [APHK1608VGCA](#) [APT2012QGW](#) [CLX6D-FKB-CN1R1H1BB7D3D3](#) [LTST-008BGEW](#) [LTST-C250KGKT](#) [LTW-010DCG](#) [LTW-020ZDCG](#) [LTW-21TS5](#) [LTW-220DS5](#) [42-21UYC/S530-A3/TR8](#) [598-8330-117F](#) [SML-LX0402IC-TR](#) [CMDA20AYAA7D1S](#) [CMDA16AYDR7A1X](#) [91-21SYGD/S530-E2/TR7](#) [598-8040-100F](#) [598-8070-100F](#) [598-8140-100F](#) [598-8610-200F](#) [EAST2012GA0](#) [EAPL3527GA5](#) [SML-LXL1209SYC/ATR](#) [EAST2012RA0](#) [EAST1608RGBAO](#) [LTW-008RGB2-PH1](#) [CMD91-21VRC/TR7](#)