

**SURFACE MOUNT
SCHOTTKY BARRIER DIODE**

**REVERSE VOLTAGE – 30 Volts
FORWARD CURRENT – 0.2 Ampere**

FEATURES

- Extremely Fast Switching Speed
- Low Forward Voltage
- Very Small Conduction Losses

MECHANICAL DATA

- Case: SOT-23 Plastic
- Case Material: “Green” molding compound, UL flammability classification 94V-0, (No Br. Sb. Cl)
- Moisture Sensitivity: Level 1 per J-STD-020D
- Lead Free in RoHS 2002/95/EC Compliant

SOT-23

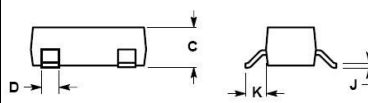
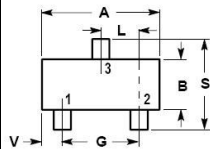

SOT-23		
Dim.	Min.	Max.
A	2.80	3.04
B	1.20	1.40
C	0.89	1.11
D	0.37	0.50
G	1.78	2.04
J	0.085	0.177
K	0.35	0.69
L	0.89	1.02
S	2.10	2.64
V	0.45	0.60
Dimensions in millimeter		

Maximum Ratings & Thermal Characteristics @ T_A = 25°C unless otherwise specified

Characteristic	Symbol	BAT54	BAT54A	BAT54C	BAT54S	Units
Repetitive Peak Reverse Voltage Working Peak Reverse Voltage DC Blocking Voltage	V _R RM V _R RWM V _R	30				V
Forward Continuous Current	I _{FM}	200				mA
Forward Surge Current @t<1.0s	I _{FSM}	600				mA
Power Dissipation	P _D	200				mW
Operating Temperature Range	T _J	125				°C
Storage Temperature Range	T _{STG}	-55~+150				°C

Electrical Characteristics @ T_A = 25°C unless otherwise specified

Characteristic	Test Condition	Symbol	BAT54	BAT54A	BAT54C	BAT54S	Unit
Reverse Breakdown Voltage	I _R = 100uA	V _{BR}	30				V
Maximum Forward Voltage	I _F = 0.1mA I _F = 1mA I _F = 10mA I _F = 30mA I _F = 100mA	V _F	240 320 400 500 1000				mV
Maximum DC Reverse Current at Rated DC Blocking Voltage	V _R = 25V	I _R	2				uA
Typical Diode Capacitance	V _R = 1.0V, f = 1MHz	C _D	10				pF
Reverse Recovery time	I _{rr} = 1mA, I _R = I _F = 10mA R _L = 100Ω	t _{rr}	5				nS

RATING AND CHARACTERISTIC CURVES

BAT54, BAT54A / C / S



FIG.1- TYPICAL FORWARD CHARACTERISTICS

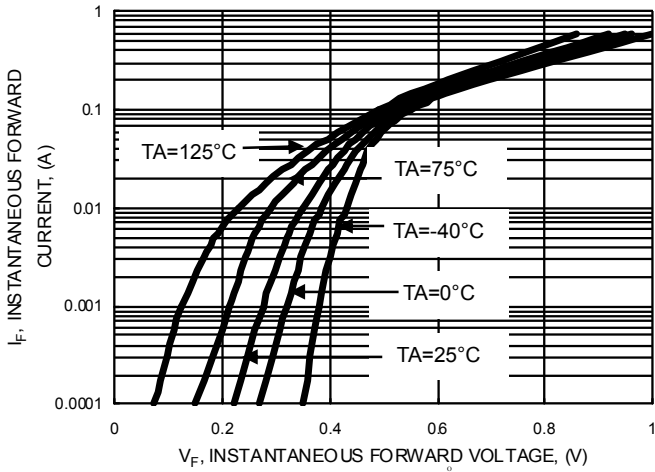

FIG.2- TYPICAL REVERSE CHARACTERISTICS

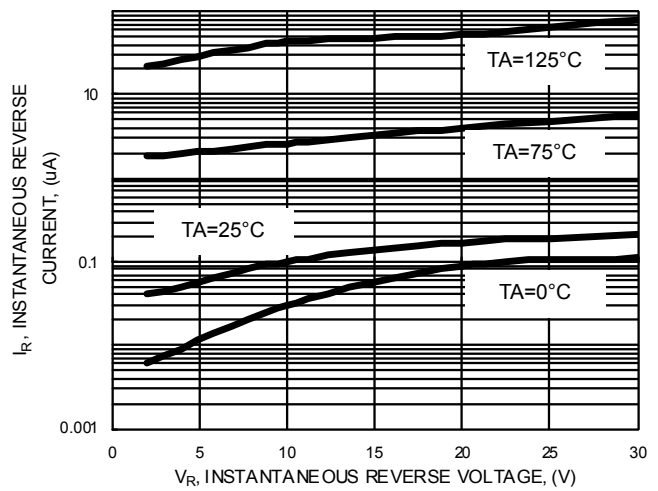

FIG.3- TYPICAL JUNCTION CAPACITANCE

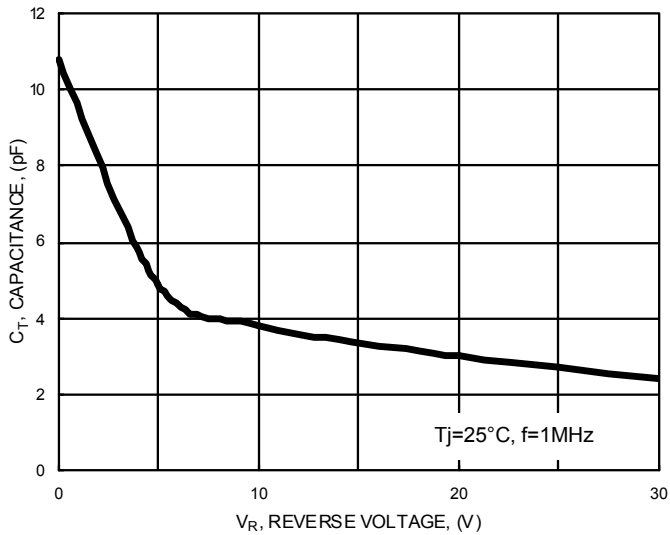
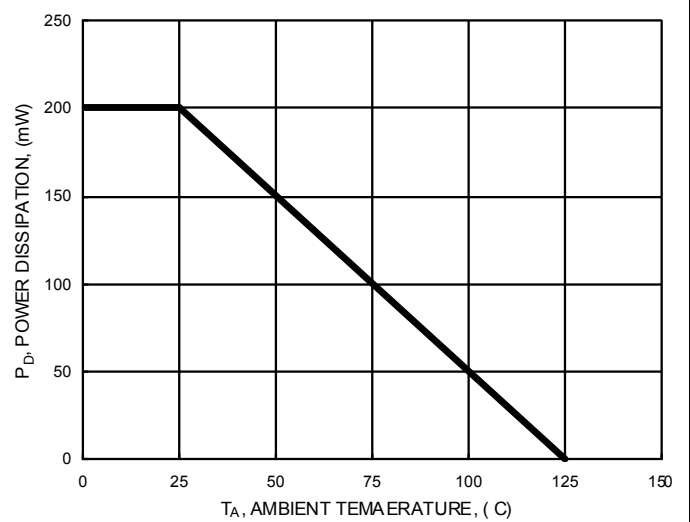

FIG.4- POWER DERATING CURVE



Device Marking :

Device P/N	Marking	Equivalent Circuit Diagram
BAT54	JV3	
BAT54A	B6	
BAT54C	5C	
BAT54S	LD3	

Important Notice and Disclaimer

LSC reserves the right to make changes to this document and its products and specifications at any time without notice. Customers should obtain and confirm the latest product information and specifications before final design, purchase or use.

LSC makes no warranty, representation or guarantee regarding the suitability of its products for any particular purpose, nor does LSC assume any liability for application assistance or customer product design. LSC does not warrant or accept any liability with products which are purchased or used for any unintended or unauthorized application.

No license is granted by implication or otherwise under any intellectual property rights of LSC.

LSC products are not authorized for use as critical components in life support devices or systems without express written approval of LSC.

New Marking Rule Notification

Range: In order to have well management in process control, the new marking rule is applied to small signal device including Switching Diode, Transistor and Schottky Diode.

Package: SOT-23 / SOT-323 / SOT-523

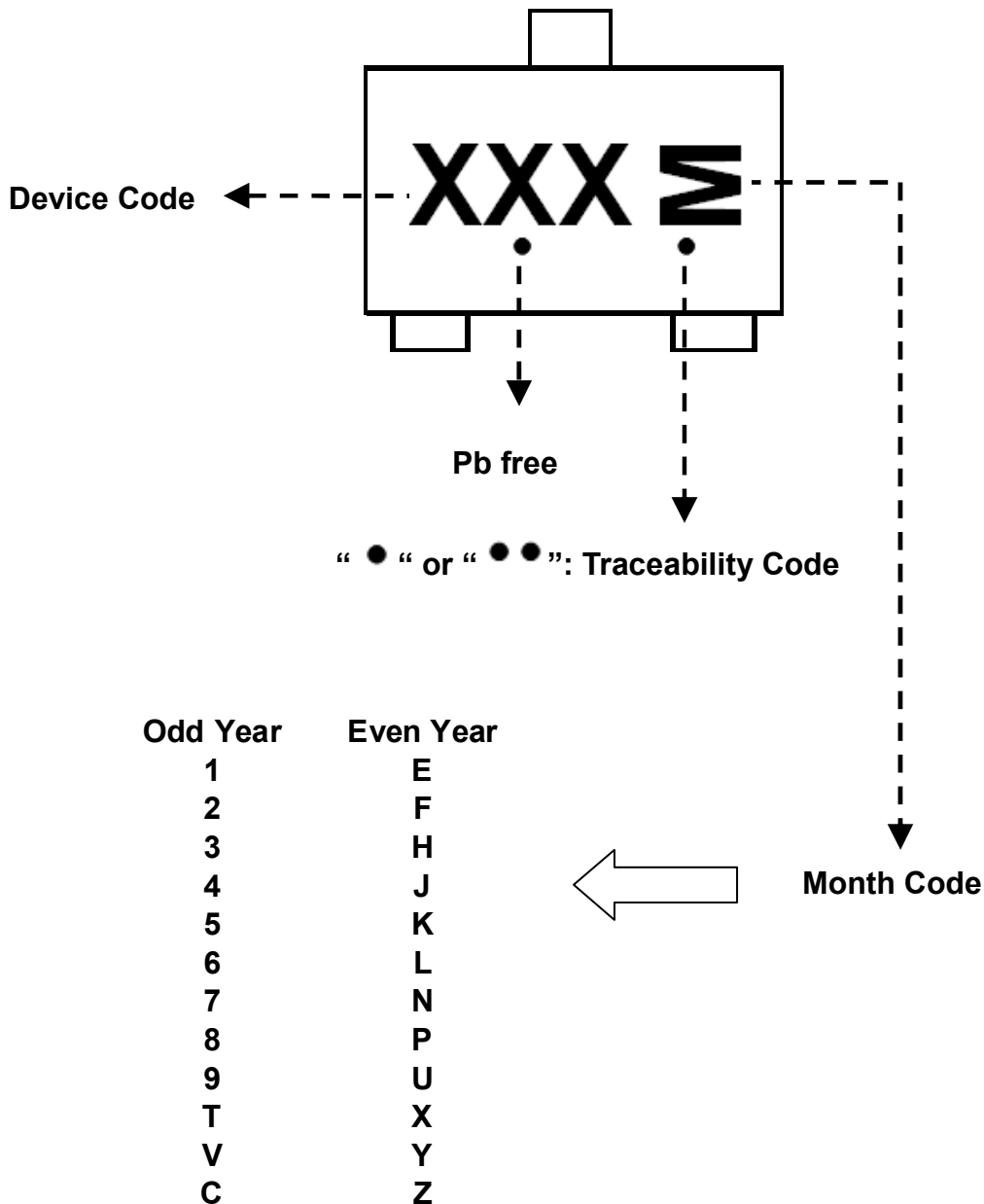

X-ON Electronics

Largest Supplier of Electrical and Electronic Components

Click to view similar products for [Schottky Diodes & Rectifiers](#) category:

Click to view products by [Lite-On](#) manufacturer:

Other Similar products are found below :

[CUS06\(Te85L,Q,M\)](#) [MA4E2039](#) [D1FH3-5063](#) [MBR0530L-TP](#) [MBR10100CT-BP](#) [MBR30H100MFST1G](#) [MMBD301M3T5G](#) [PMAD1103-LF](#) [PMAD1108-LF](#) [RB160M-50TR](#) [RB520S-30](#) [RB551V-30](#) [DD350N18K](#) [DZ435N40K](#) [DZ600N16K](#) [BAS16E6433HTMA1](#) [BAS 3010S-02LRH E6327](#) [BAT 54-02LRH E6327](#) [IDL02G65C5XUMA1](#) [NSR05F40QNXT5G](#) [NSVR05F40NXT5G](#) [JANS1N6640](#) [SB07-03C-TB-H](#) [SB1003M3-TL-W](#) [SBAT54CWT1G](#) [SBM30-03-TR-E](#) [SBS818-TL-E](#) [SK32A-LTP](#) [SK33A-TP](#) [SK34A-TP](#) [SK34B-TP](#) [SMD1200PL-TP](#) [ACDBN160-HF](#) [SS3003CH-TL-E](#) [STPS30S45CW](#) [PDS3100Q-7](#) [GA01SHT18](#) [CRS10I30A\(Te85L,QM\)](#) [MBR1240MFST1G](#) [MBRB30H30CT-1G](#) [BAS28E6433HTMA1](#) [BAS 70-02L E6327](#) [HSB123JTR-E](#) [JANTX1N5712-1](#) [VS-STPS40L45CW-N3](#) [DD350N12K](#) [SB007-03C-TB-E](#) [SB10015M-TL-E](#) [SB1003M3-TL-E](#) [SK110-LTP](#)