

Revision Control Record

Rev.	Description of Change	ECN No.	Date
E	REVISED DRAWING, SSR	07035	1/25/07
F	BOM CHANGE	09588	01/15/10

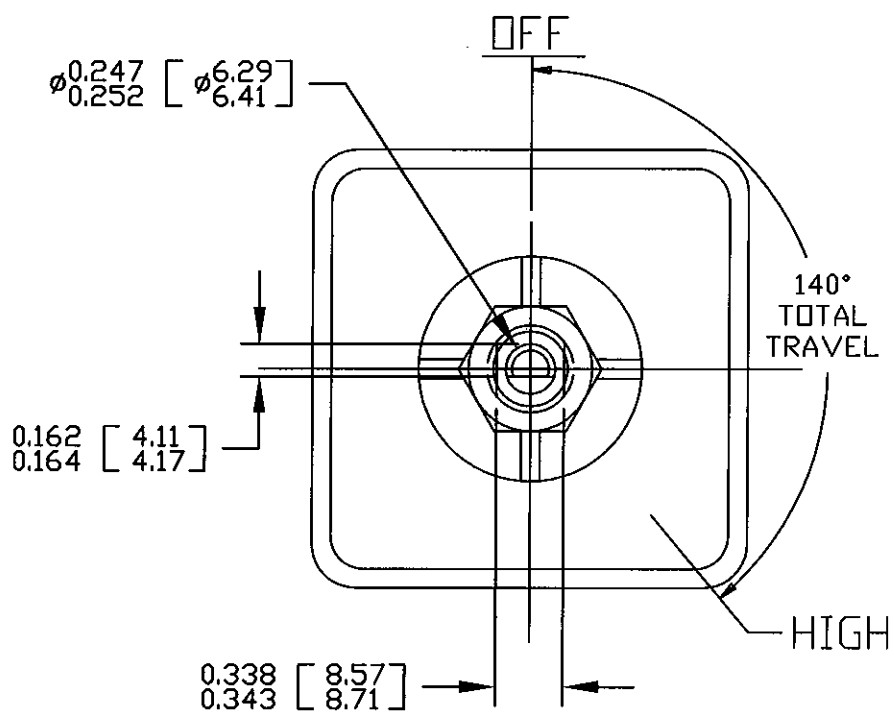

FRONT VIEW OF KNOB

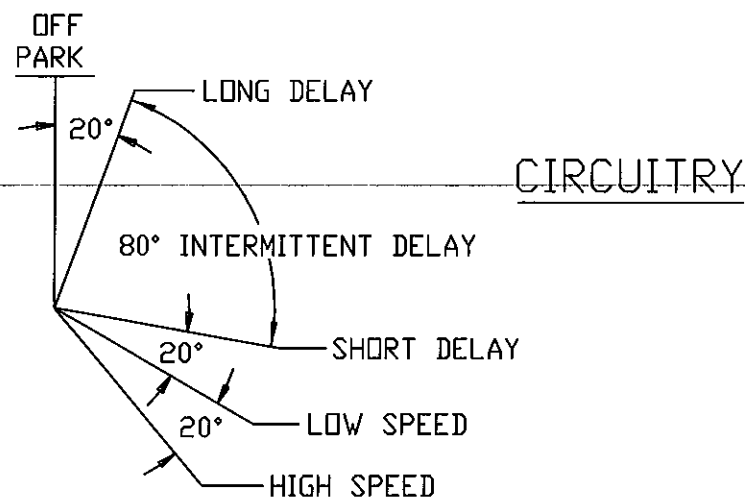
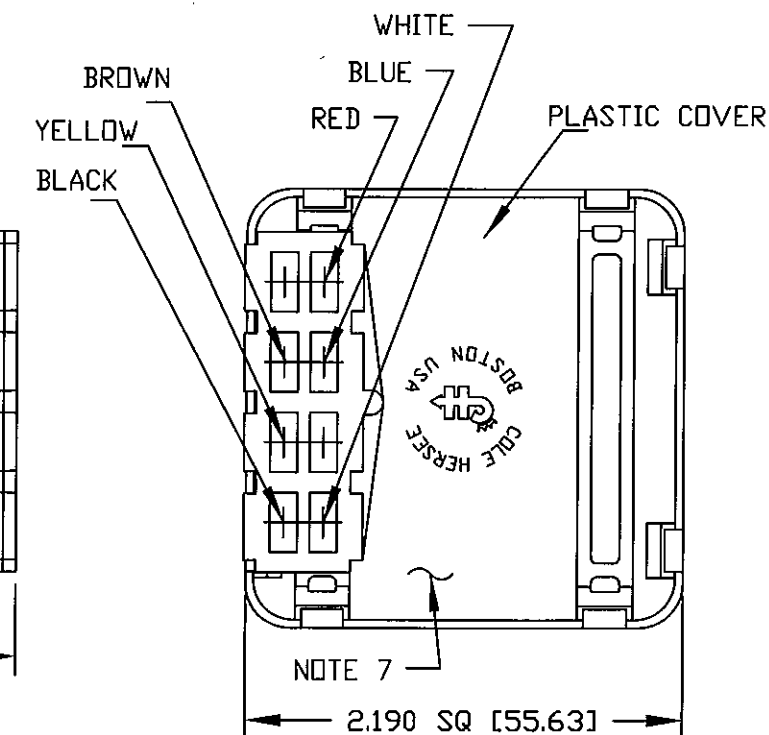
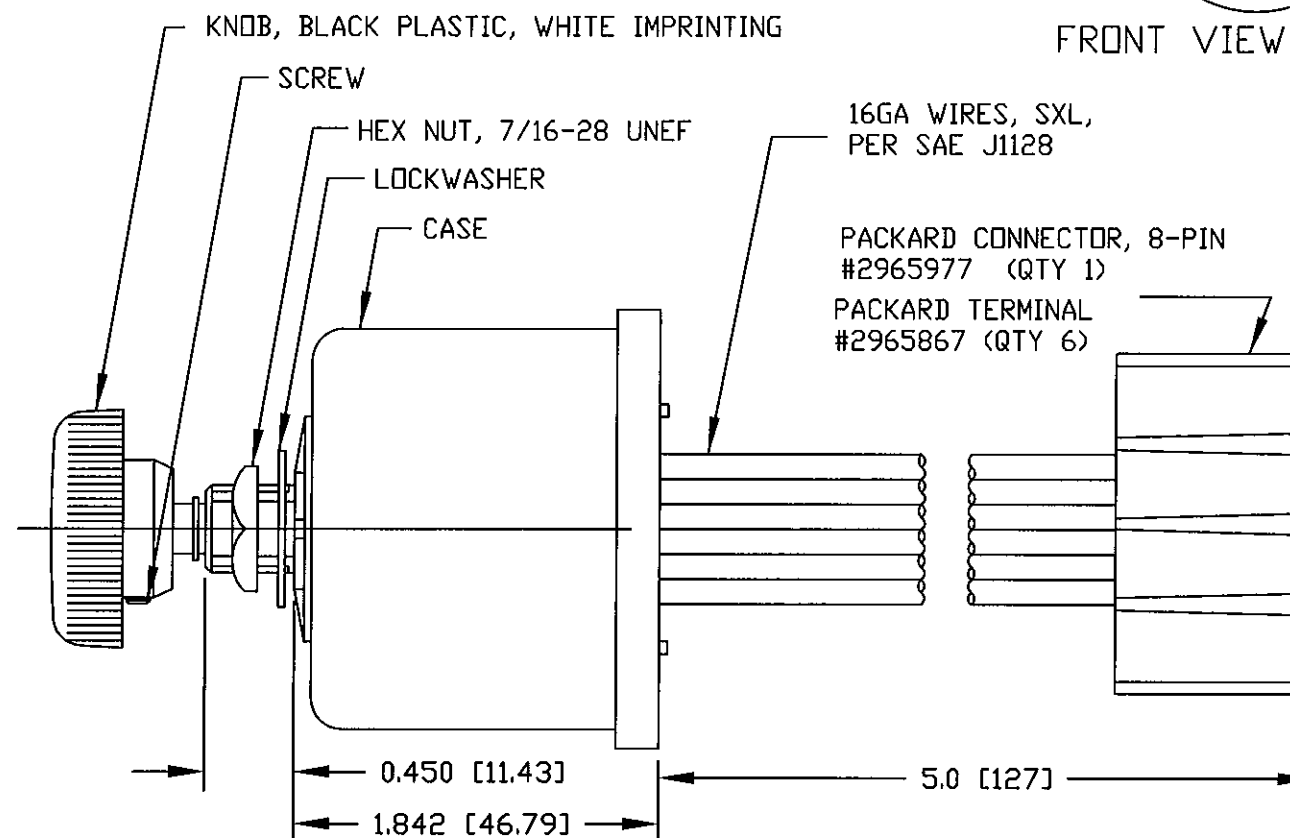

NOTES:

- DESIGNED FOR 12V SYSTEM, SINGLE MOTOR, DYNAMIC AND NON-DYNAMIC PARK. TO BE USED WITH PERMANENT MAGNET MOTOR, NEGATIVE GROUND ONLY.
- PUSH TO WASH FUNCTION: RESULTS IN 2 TO 3 WIPES AFTER RELEASE OF PUSH SWITCH.
- RATING: VOLTAGE OPERATING RANGE 9VDC TO 16VDC
 ROTARY SWITCH ACTUATION 20,000 CYCLES MINIMUM.
 MOTOR DRIVE: 15 AMPS CONTINUOUS. START-UP/STALL/LOCKED-ROTOR 50 AMPS. SHORT-CIRCUIT PROOF.
 WASHER CIRCUIT 3 AMPS, PUSH SWITCH 20,000 CYCLES MINIMUM.
- MICROPROCESSOR CONTROLLED, SOLID-STATE RELAY, CURRENT LIMIT SENSE CIRCUIT, REVERSE POLARITY PROTECTED
- CONFORMS TO SAE J1455:
 4.11 GENERAL HEAVY DUTY TRUCK ELECTRICAL ENVIRONMENT.
 4.11.1 STEADY-STATE ELECTRICAL CHARACTERISTICS.
 4.11.2 TRANSIENT, NOISE AND ELECTROSTATIC CHARACTERISTICS.
- ENVIRONMENTAL EXTREMES BY LOCATION.
 5.2 INTERIOR-FORWARD.
- ALL DIMENSIONS ARE REFERENCE ONLY UNLESS NOTED OTHERWISE.
 7. COLE HERSEE PART NUMBER, REVISION, & DATE CODE STAMPED IN WHITE.

COLOR	FUNCTION
WHITE	MOTOR HIGH SPEED
YELLOW	MOTOR LOW SPEED
BLACK	GROUND (0V)
BROWN	WASHER PUMP
RED	VBB (12V)
BLUE	MOTOR PARK

Tolerances Unless otherwise specifically noted, the following are default tolerances:
 * 2-place Decimal Dimensions +/- .02"
 * 3-place Decimal Dimensions +/- .005"
 * Angular Dimensions +/- 1.0 Deg.
 * Metric: Refer to equivalent English Dimension Tolerance
 >>> NOTE: All tolerances are Non-Cumulative. <<<

Dimensional Units All dimensions are expressed in inches except those shown in brackets (xxx) are expressed in millimeters

"REF." or an Asterisk (*) = Non-Toleranced Reference Dimension, shown for clarification purposes only.

PROPRIETARY INFORMATION This Engineering Drawing, and the information contained herein, is proprietary to Cole Hersee Company and may not be disclosed, re-produced, or in any other way transferred or communicated to any other party without the express written consent of an authorized representative of Cole Hersee Company.

DESIGN CONTROL It is the responsibility of the individual using / referencing this drawing to assure that the noted design revision level agrees with the revision level of the Controlled Document (Master Drawing). This is a NON-CONTROLLED DOCUMENT unless otherwise specifically noted.

DO NOT SCALE - Dimensional variation may occur during printing / reproduction.

Special Characteristics:

- Ⓢ Critical Characteristic, relating to Safety and/or Regulatory Compliance
- Ⓧ Significant Characteristic relating to Process Control (SPC)
- Ⓚ Control Dimension relating to Form - Fit - Function as defined by Cole Hersee Company and/or the Customer

(Note that the identification of any Characteristics as being "Special" does not alter the requirement that ALL specified dimensions & tolerances must be met.)

Cole Hersee Co.
 20 Old Colony Ave., South Boston, MA, 02127
 Phn: 617-268-2100 Web: www.colehersee.com

Description: WINDSHIELD WIPER CONTROLLER, UNIVERSAL, 12V

Drawing / Part No.: 75600

Current Rev.: F

Revision Control Record

Rev.	Description of Change	ECN No.	Date
E	ADDED NOTE TO COVER VIEW	03274	7/24/03
F	CHANGE TO SSR PCB	07060	02/16/07
G	BOM CHANGE	09587	01/13/10

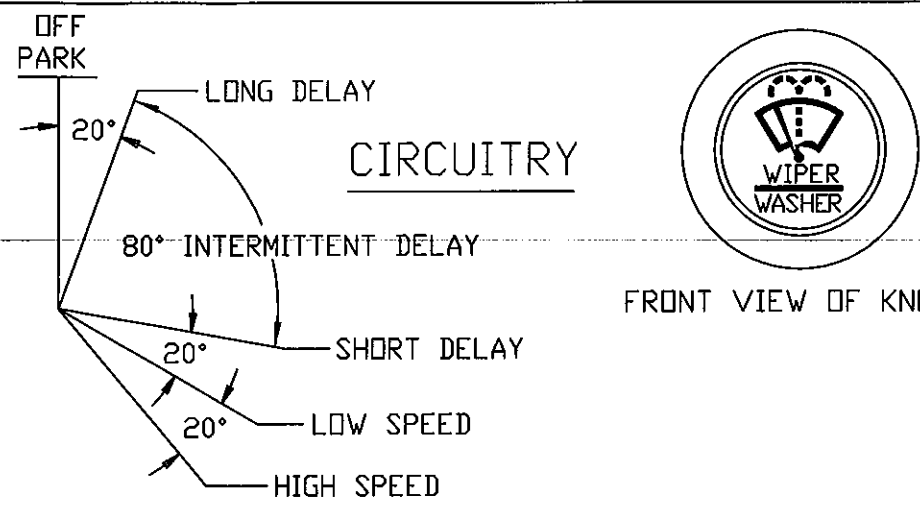

FRONT VIEW OF KNOB

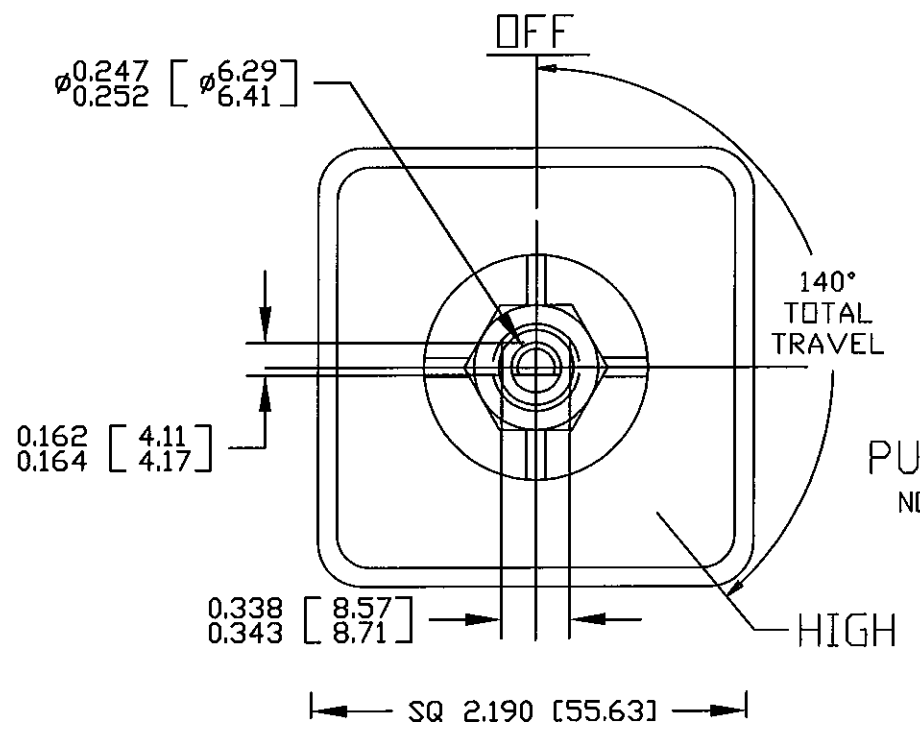

PUSH TO WASH
NOTE 2

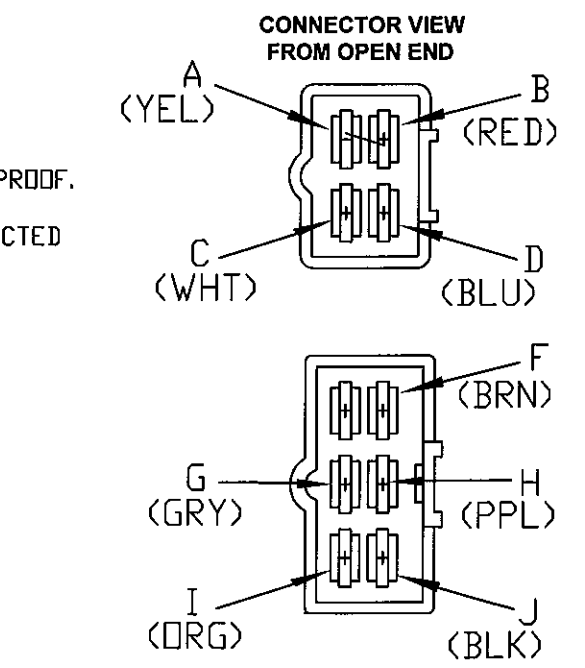
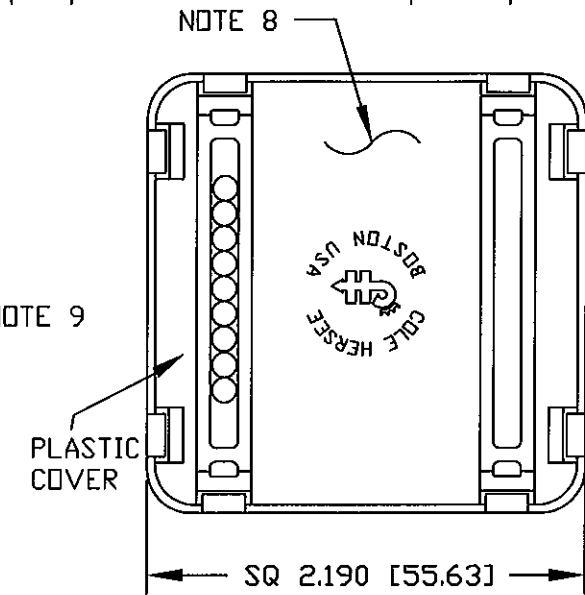
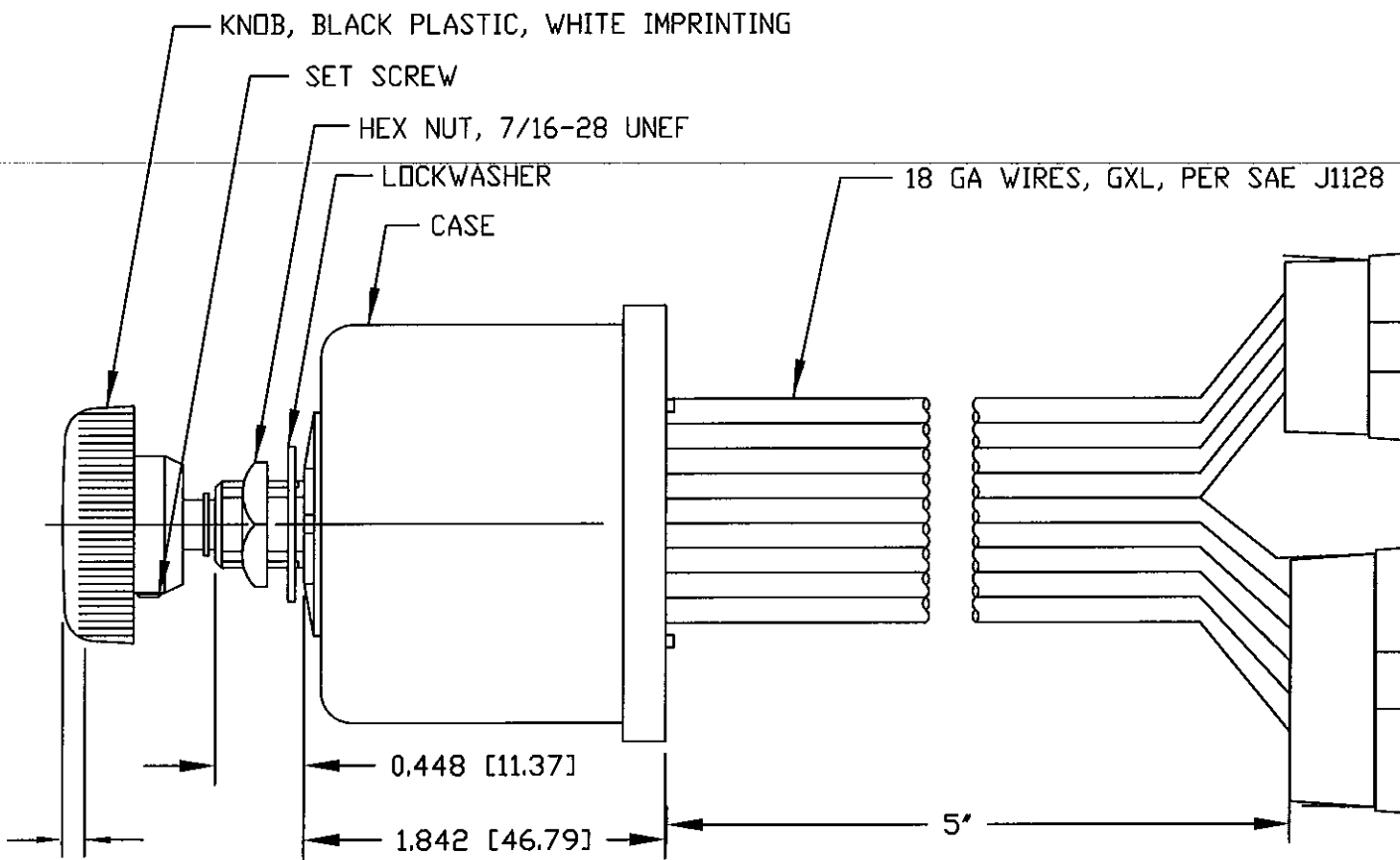

NOTES:

- DESIGNED FOR 12V SYSTEM, DUAL MOTOR, DYNAMIC AND NON-DYNAMIC PARK.
- PUSH TO WASH FUNCTION RESULTS IN 3 WIPES AFTER RELEASE OF PUSH SWITCH.
- RATING: VOLTAGE OPERATING RANGE 9VDC TO 16VDC
 ROTARY SWITCH ACTUATION 20,000 CYCLES MINIMUM.
 MOTOR DRIVE: 10 AMPS PER MOTOR CONTINUOUS. START-UP/STALL/LOCKED-ROTOR 30 AMPS. SHORT-CIRCUIT PROOF.
 WASHER CIRCUIT 3 AMPS, PUSH SWITCH 20,000 CYCLES MINIMUM.
- MICROPROCESSOR CONTROLLED, SOLID-STATE RELAY, CURRENT LIMIT SENSE CIRCUIT, REVERSE POLARITY PROTECTED
- CONFORMS TO SAE J1455:
 4.11 GENERAL HEAVY DUTY TRUCK ELECTRICAL ENVIRONMENT.
 4.11.1 STEADY-STATE ELECTRICAL CHARACTERISTICS.
 4.11.2 TRANSIENT, NOISE AND ELECTROSTATIC CHARACTERISTICS.
- INTERMITTENT DELAYS: 1, 2, 4, 7, 11 AND 16 SECONDS
- ALL DIMENSIONS ARE REFERENCE ONLY UNLESS NOTED OTHERWISE.
- COLE HERSEE PART NUMBER, REVISION, & DATE CODE STAMPED IN WHITE ON REAR PLASTIC COVER.
- CONNECTORS, DELPHI: 6-PIN, PART# 2977042 (QTY 1); 4-PIN, PART# 6294544 (QTY 1)
 TERMINALS, DELPHI: PART#2965439 (QTY 10)

COLOR	FUNCTION	TERMINAL
YELLOW	LOW-SPEED MOTOR #1	A
RED	VBB (12V POWER)	B
WHITE	HIGH-SPEED MOTOR#1	C
BLUE	PARK MOTOR #1	D
BROWN	WASHER	F
GREY	HIGH-SPEED MOTOR #2	G
PURPLE	PARK MOTOR #2	H
ORANGE	LOW-SPEED MOTOR #2	I
BLACK	GROUND (0V)	J

Tolerances Unless otherwise specifically noted, the following are default tolerances:
 * 2-place Decimal Dimensions +/- .02"
 * 3-place Decimal Dimensions +/- .005"
 * Angular Dimensions +/- 1.0 Deg.
 * Metric: Refer to equivalent English Dimension Tolerance
 >>> NOTE: All tolerances are Non-Cumulative. <<<

Dimensional Units All dimensions are expressed in inches except those shown in brackets (xxx) are expressed in millimeters

"REF." or an Asterisk (*) = Non-Toleranced Reference Dimension, shown for clarification purposes only.

Used On or Ref.: **EX28333** Scale: **1:1**

PROPRIETARY INFORMATION This Engineering Drawing, and the information contained herein, is proprietary to Cole Hersee Company and may not be disclosed, re-produced, or in any other way transferred or communicated to any other party without the express written consent of an authorized representative of Cole Hersee Company.

DESIGN CONTROL It is the responsibility of the Individual using / referencing this drawing to assure that the noted design revision level agrees with the revision level of the Controlled Document (Master Drawing). This is a NON-CONTROLLED DOCUMENT unless otherwise specifically noted.

DO NOT SCALE - Dimensional variation may occur during printing / reproduction.

Drawn **JCS** Date **10/10/06**

Special Characteristics:

- Critical Characteristic, relating to Safety and/or Regulatory Compliance
- Significant Characteristic relating to Process Control (SPC)
- Control Dimension relating to Form - Fit - Function as defined by Cole Hersee Company and/or the Customer

(Note that the identification of any Characteristics as being "Special" does not alter the requirement that ALL specified dimensions & tolerances must be met.)

Responsible Engineer: **JCS** Pg. **1**

Cole Hersee Co.
 20 Old Colony Ave., South Boston, MA, 02127
 Phn: 617-268-2100 Web: www.colehersee.com

Description:
WINDSHIELD WIPER CONTROLLER, DUAL-MOTOR, W/ WIPER ENABLE, 12V, SSR

Drawing / Part No.: **75600-01** Current Rev.: **G**

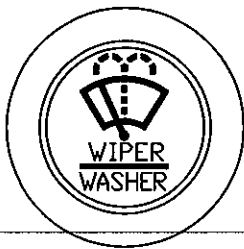

Revision Control Record

Rev.	Description of Change	ECN No.	Date
L	REVISED DRAWING, SSR	07035	1/24/07
M	EDIT NOTE 7	09257	04/21/09
N	BOM CHANGE	09588	01/15/10

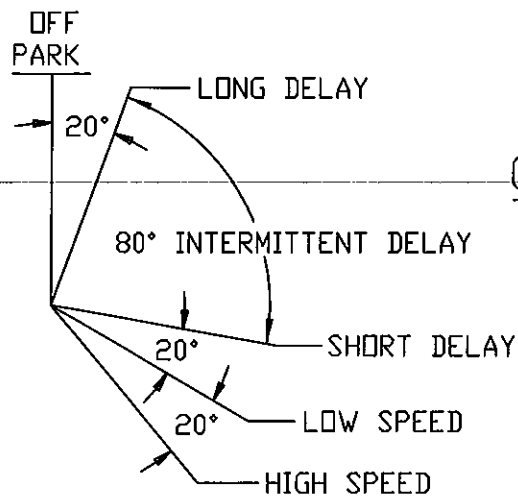

CIRCUITRY

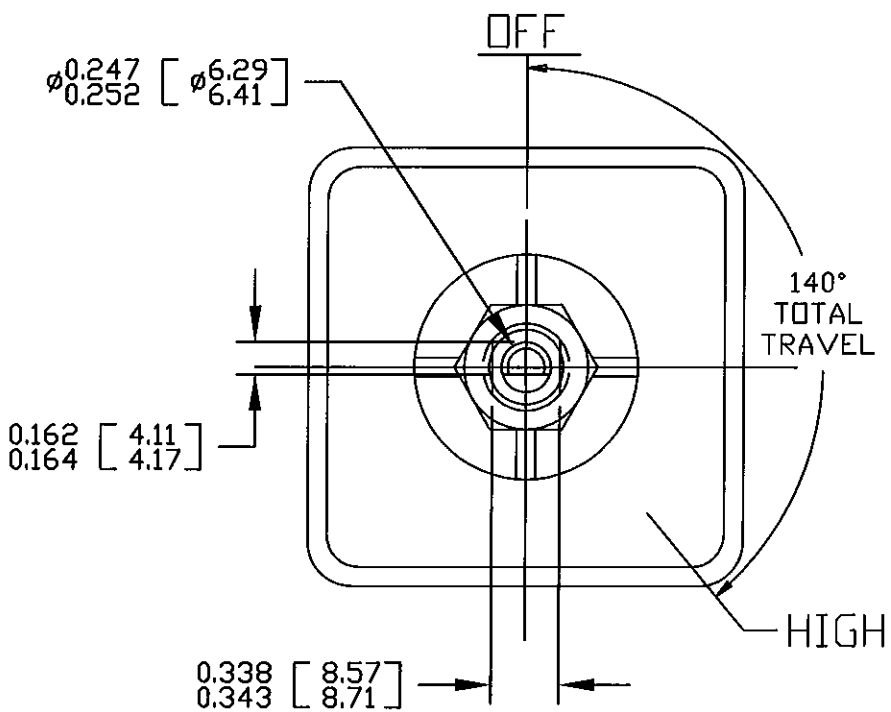

FRONT VIEW OF KNOB

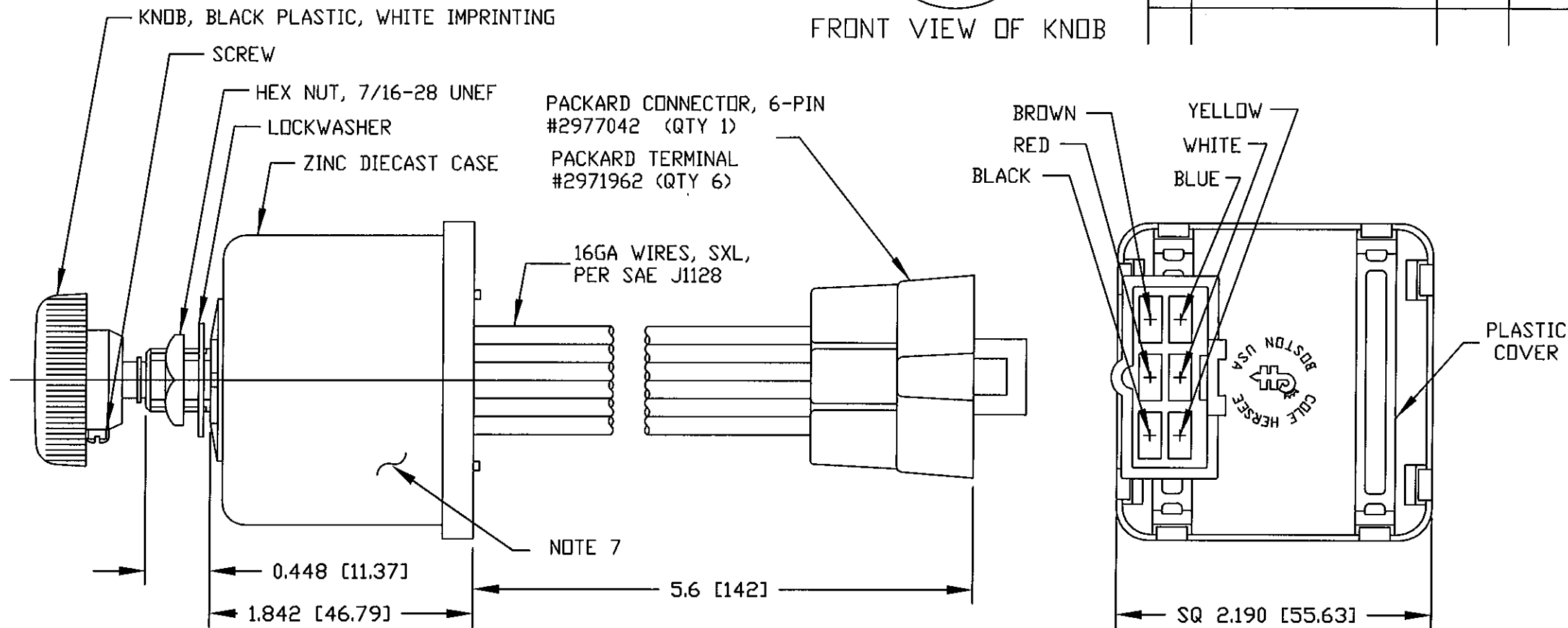

NOTES:

- DESIGNED FOR 12V SYSTEM, SINGLE MOTOR, DYNAMIC AND NON-DYNAMIC PARK. TO BE USED WITH PERMANENT MAGNET MOTOR, NEGATIVE GROUND ONLY.
- PUSH TO WASH FUNCTION: RESULTS IN 2 TO 3 WIPES AFTER RELEASE OF PUSH SWITCH.
- RATING: VOLTAGE OPERATING RANGE 9VDC TO 16VDC
 ROTARY SWITCH ACTUATION 20,000 CYCLES MINIMUM.
 MOTOR DRIVE: 15 AMPS CONTINUOUS. START-UP/STALL/LOCKED-ROTOR 50 AMPS. SHORT-CIRCUIT PROOF.
 WASHER CIRCUIT 3 AMPS, PUSH SWITCH 20,000 CYCLES MINIMUM.
- MICROPROCESSOR CONTROLLED, SOLID-STATE RELAY, CURRENT LIMIT SENSE CIRCUIT, REVERSE POLARITY PROTECTED
- CONFORMS TO SAE J1455:
 - GENERAL HEAVY DUTY TRUCK ELECTRICAL ENVIRONMENT.
 - STEADY-STATE ELECTRICAL CHARACTERISTICS.
 - TRANSIENT, NOISE AND ELECTROSTATIC CHARACTERISTICS.
 - ENVIRONMENTAL EXTREMES BY LOCATION.
 - INTERIOR-FORWARD.
- ALL DIMENSIONS ARE REFERENCE ONLY UNLESS NOTED OTHERWISE.
- COLE HERSEE PART NUMBER, REVISION, & DATE CODE MARKED AT RANDOM ON CASE.

COLOR	FUNCTION
WHITE	MOTOR HIGH SPEED
YELLOW	MOTOR LOW SPEED
RED	VBB (+12V)
BROWN	WASHER PUMP
BLACK	GROUND (0V)
BLUE	MOTOR PARK

Tolerances Unless otherwise specifically noted, the following are default tolerances:
 * 2-place Decimal Dimensions +/- .02"
 * 3-place Decimal Dimensions +/- .005"
 * Angular Dimensions +/- 1.0 Deg.
 * Metric: Refer to equivalent English Dimension Tolerance
 >>> NOTE: All tolerances are Non-Cumulative. <<<

Dimensional Units All dimensions are expressed in inches except those shown in brackets (xxx) are expressed in millimeters

"REF." or an Asterisk (*) = Non-Toleranced Reference Dimension, shown for clarification purposes only.

Used On or Ref.: **EX26541** Scale: **1:1**

PROPRIETARY INFORMATION This Engineering Drawing, and the information contained herein, is proprietary to Cole Hersee Company and may not be disclosed, re-produced, or in any other way transferred or communicated to any other party without the express written consent of an authorized representative of Cole Hersee Company.

DESIGN CONTROL It is the responsibility of the individual using / referencing this drawing to assure that the noted design revision level agrees with the revision level of the Controlled Document (Master Drawing). This is a NON-CONTROLLED DOCUMENT unless otherwise specifically noted.

DO NOT SCALE - Dimensional variation may occur during printing / reproduction.

Drawn By: **DPS** Date Drawn: **1/23/07**

Special Characteristics:

- Critical Characteristic, relating to Safety and/or Regulatory Compliance
- Significant Characteristic relating to Process Control (SPC)
- Control Dimension relating to Form - Fit - Function as defined by Cole Hersee Company and/or the Customer

(Note that the Identification of any Characteristics as being "Special" does not alter the requirement that ALL specified dimensions & tolerances must be met.)

Responsible Engineer: **JCS** Pg. **1**

Cole Hersee Co.
 20 Old Colony Ave., South Boston, MA, 02127
 Phn: 617-268-2100 Web: www.colehersee.com

Description: WINDSHIELD WIPER CONTROLLER, UNIVERSAL, 12V

Drawing / Part No.: **75600-02** **Current Rev.:** **N**

Revision Control Record			
Rev.	Description of Change	ECN No.	Date
L	CHANGE BOM	09588	01/15/10
M	CHANGE NOTE 3	13054	02/07/13

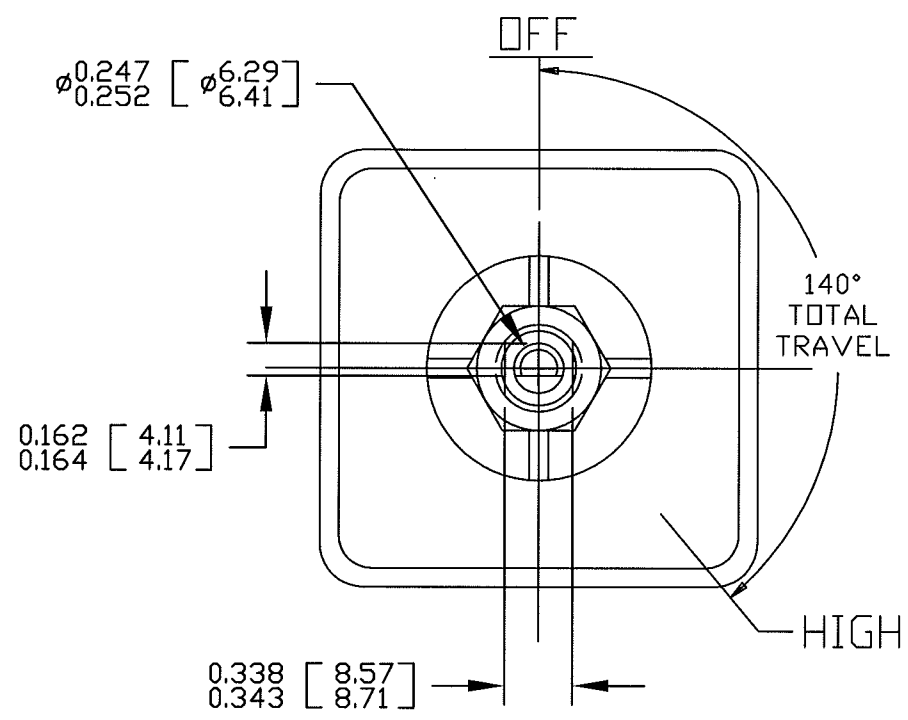
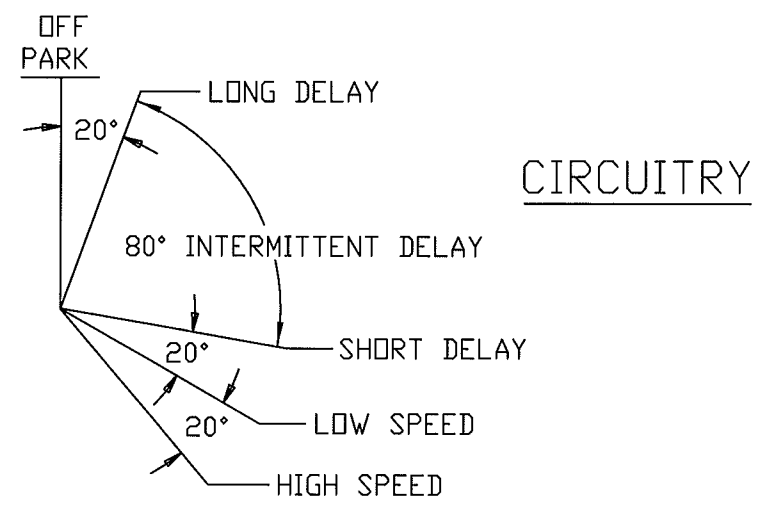

FRONT VIEW OF KNOB

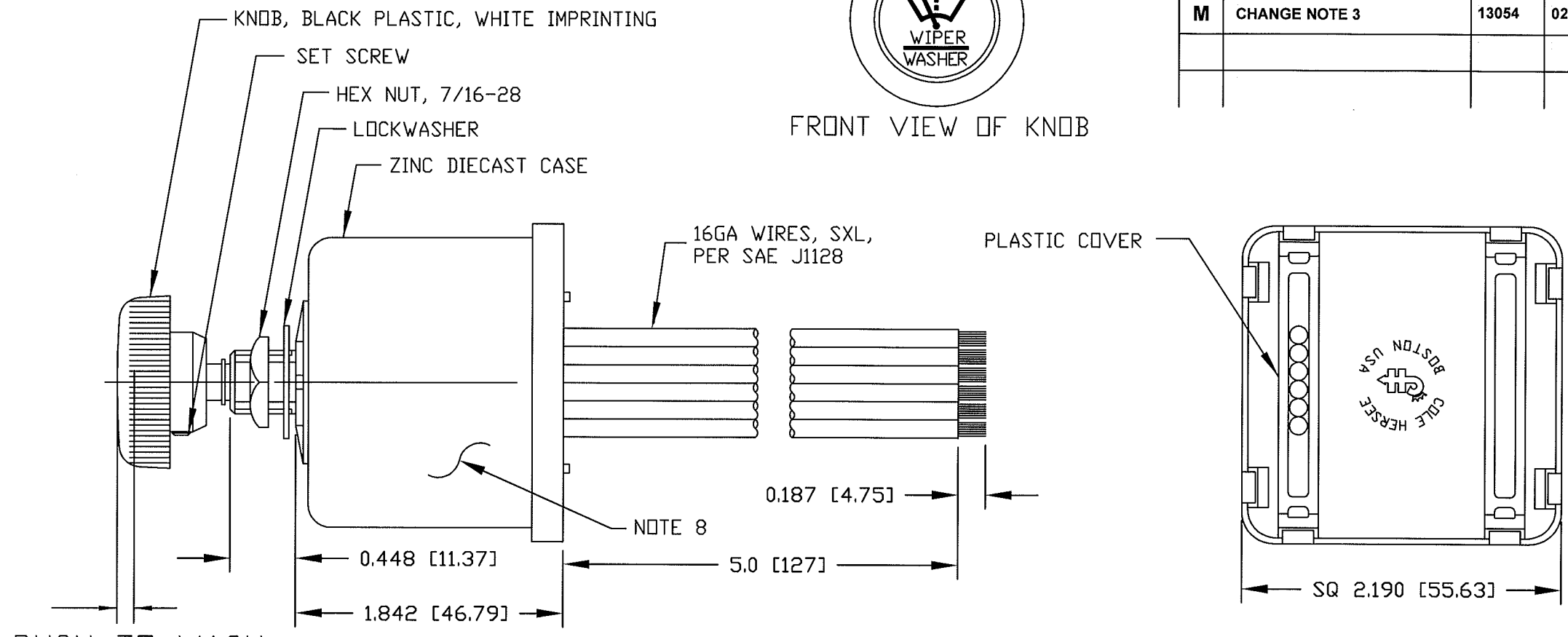

- NOTES:**
- DESIGNED FOR 12V SYSTEM, SINGLE MOTOR, DYNAMIC AND NON-DYNAMIC PARK. TO BE USED WITH PERMANENT MAGNET MOTOR, NEGATIVE GROUND ONLY.
 - PUSH TO WASH FUNCTION: RESULTS IN 2 TO 3 WIPES AFTER RELEASE OF PUSH SWITCH.
 - RATING: VOLTAGE OPERATING RANGE 9VDC TO 16VDC
ROTARY SWITCH ACTUATION 20,000 CYCLES MINIMUM.
MOTOR DRIVE: 15 AMPS CONTINUOUS. START-UP/STALL/LOCKED-ROTOR 50 AMPS. SHORT-CIRCUIT PROTECTED (M)
WASHER CIRCUIT 3 AMPS, PUSH SWITCH 20,000 CYCLES MINIMUM.
 - MICROPROCESSOR CONTROLLED, SOLID-STATE RELAY, CURRENT LIMIT SENSE CIRCUIT, REVERSE POLARITY PROTECTED
 - CONFORMS TO SAE J1455:
4.11 GENERAL HEAVY DUTY TRUCK ELECTRICAL ENVIRONMENT.
4.11.1 STEADY-STATE ELECTRICAL CHARACTERISTICS.
4.11.2 TRANSIENT, NOISE AND ELECTROSTATIC CHARACTERISTICS.
 - ENVIRONMENTAL EXTREMES BY LOCATION.
5.2 INTERIOR-FORWARD.
 - ALL STEEL PARTS PLATED
 - ALL DIMENSIONS ARE REFERENCE ONLY UNLESS NOTED OTHERWISE.
 - COLE HERSEE PART NUMBER, REVISION, & DATE CODE MARKED AT RANDOM ON CASE.

COLOR	FUNCTION
WHITE	MOTOR HIGH SPEED
YELLOW	MOTOR LOW SPEED
RED	VBB (+12V)
BROWN	WASHER PUMP
BLACK	GROUND (0V)
BLUE	MOTOR PARK

<p>Tolerances Unless otherwise specifically noted, the following are default tolerances: * 2-place Decimal Dimensions +/- .02" * 3-place Decimal Dimensions +/- .005" * Angular Dimensions +/- 1.0 Deg. * Metric: Refer to equivalent English Dimension Tolerance >>> NOTE: All tolerances are Non-Cumulative. <<<</p> <p>Dimensional Units All dimensions are expressed in inches except those shown in brackets (xxx) are expressed in millimeters</p> <p>"REF." or an Asterisk (*) = Non-Toleranced Reference Dimension, shown for clarification purposes only.</p>		<p>PROPRIETARY INFORMATION This Engineering Drawing, and the information contained herein, is proprietary to Cole Hersee Company and may not be disclosed, re-produced, or in any other way transferred or communicated to any other party without the express written consent of an authorized representative of Cole Hersee Company.</p> <p>DESIGN CONTROL It is the responsibility of the individual using / referencing this drawing to assure that the noted design revision level agrees with the revision level of the Controlled Document (Master Drawing). This is a NON-CONTROLLED DOCUMENT unless otherwise specifically noted.</p> <p>DO NOT SCALE - Dimensional variation may occur during printing / reproduction.</p>		<p>Special Characteristics:</p> <p>CC Critical Characteristic, relating to Safety and/or Regulatory Compliance</p> <p>X Significant Characteristic relating to Process Control (SPC)</p> <p>CC Control Dimension relating to Form - Fit - Function as defined by Cole Hersee Company and/or the Customer</p> <p>(Note that the identification of any Characteristics as being "Special" does not alter the requirement that ALL specified dimensions & tolerances must be met.)</p>		<p>Cole Hersee Co. 20 Old Colony Ave., South Boston, MA, 02127 Phn: 617-268-2100 Web: www.colehersee.com</p> <p>Description: WINDSHIELD WIPER CONTROLLER, UNIVERSAL, 12V</p>	
Used On or Ref.: EX28241	Scale: 1:1	Drawn By: JCS	Date Drawn: 1/9/07	Responsible Engineer: JCS	Pg. 1	Drawing / Part No.: 75600-04	Current Rev.: M

Revision Control Record

Rev.	Description of Change	ECN No.	Date
H	CHANGED TO SSR	07074	03/02/07
J	BOM CHANGE	09588	01/15/10

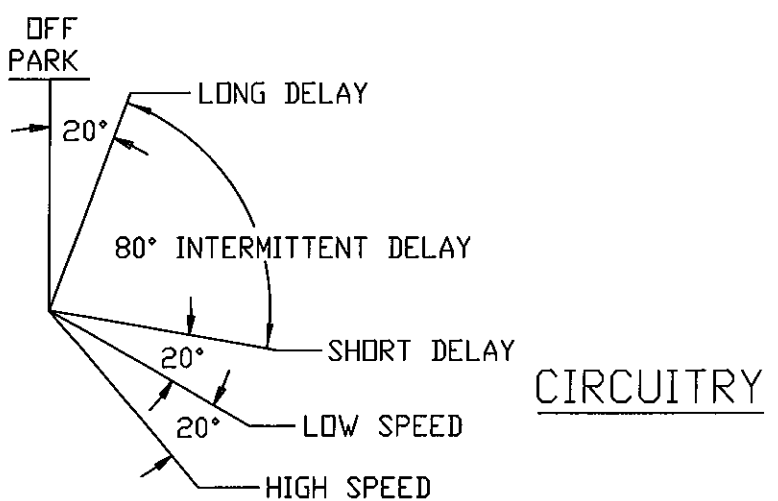
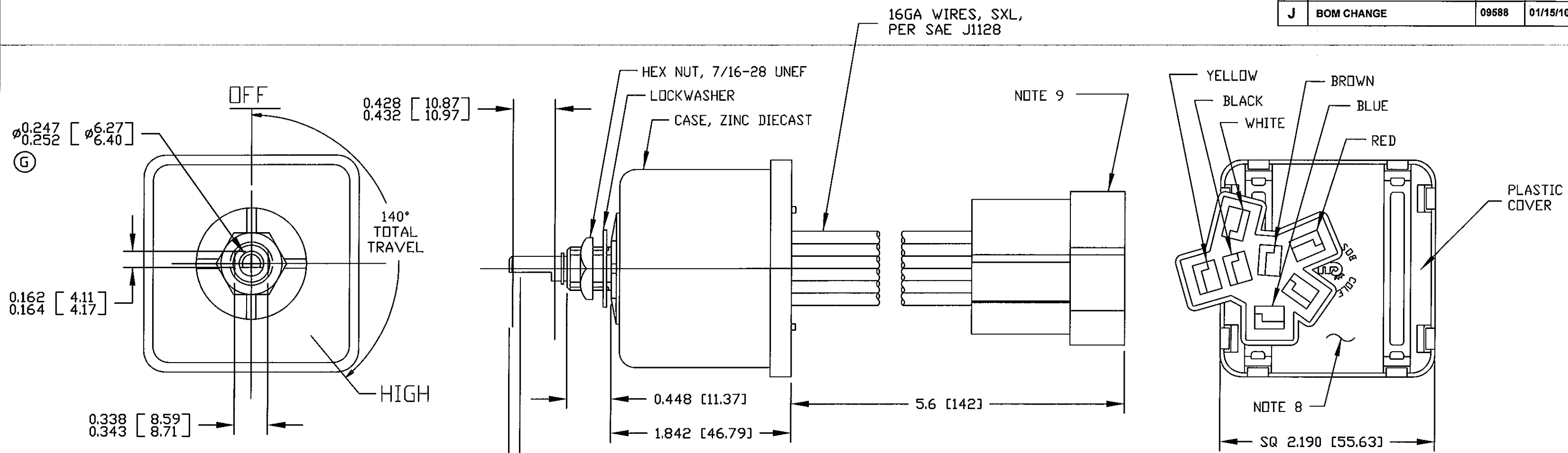

- NOTES:**
- DESIGNED FOR 12V SYSTEM, SINGLE MOTOR, DYNAMIC AND NON-DYNAMIC PARK. TO BE USED WITH PERMANENT MAGNET MOTOR, NEGATIVE GROUND ONLY.
 - PUSH TO WASH FUNCTION: RESULTS IN 2 TO 3 WIPES AFTER RELEASE OF PUSH SWITCH.
 - RATING: VOLTAGE OPERATING RANGE 9VDC TO 16VDC
 ROTARY SWITCH ACTUATION 20,000 CYCLES MINIMUM.
 MOTOR DRIVE: 15 AMPS CONTINUOUS. START-UP/STALL/LOCKED-ROTOR 50 AMPS. SHORT-CIRCUIT PROOF.
 WASHER CIRCUIT 3 AMPS, PUSH SWITCH 20,000 CYCLES MINIMUM.
 - MICROPROCESSOR CONTROLLED, SOLID-STATE RELAY, CURRENT LIMIT SENSE CIRCUIT, REVERSE POLARITY PROTECTED
 - CONFORMS TO SAE J1455:
 4.11 GENERAL HEAVY DUTY TRUCK ELECTRICAL ENVIRONMENT.
 4.11.1 STEADY-STATE ELECTRICAL CHARACTERISTICS.
 4.11.2 TRANSIENT, NOISE AND ELECTROSTATIC CHARACTERISTICS.
 - ENVIRONMENTAL EXTREMES BY LOCATION.
 5.2 INTERIOR-FORWARD.
 - ALL STEEL PARTS PLATED.
 - ALL DIMENSIONS ARE REFERENCE ONLY UNLESS NOTED OTHERWISE.
 - COLE HERSEE PART NUMBER, REVISION, & DATE CODE STAMPED IN WHITE.
 - CONNECTOR: DILL #059074. TERMINALS: DELPHI #12020126, QTY 6

COLOR	FUNCTION
WHITE	MOTOR HIGH SPEED
YELLOW	MOTOR LOW SPEED
BLACK	GROUND (0V)
BROWN	WASHER PUMP
RED	VBB (12V)
BLUE	MOTOR PARK

Tolerances Unless otherwise specifically noted, the following are default tolerances:
 • 2-place Decimal Dimensions +/- .02"
 • 3-place Decimal Dimensions +/- .005"
 • Angular Dimensions +/- 1.0 Deg.
 • Metric: Refer to equivalent English Dimension Tolerance
 >>> NOTE: All tolerances are Non-Cumulative. <<<

Dimensional Units All dimensions are expressed in inches except those shown in brackets (xxx) are expressed in millimeters

"REF." or an Asterisk (*) = Non-Toleranced Reference Dimension, shown for clarification purposes only.

PROPRIETARY INFORMATION This Engineering Drawing, and the information contained herein, is proprietary to Cole Hersee Company and may not be disclosed, re-produced, or in any other way transferred or communicated to any other party without the express written consent of an authorized representative of Cole Hersee Company.

DESIGN CONTROL It is the responsibility of the individual using / referencing this drawing to assure that the noted design revision level agrees with the revision level of the Controlled Document (Master Drawing). This is a NON-CONTROLLED DOCUMENT unless otherwise specifically noted.

DO NOT SCALE - Dimensional variation may occur during printing / reproduction.

Special Characteristics:

- Critical Characteristic, relating to Safety and/or Regulatory Compliance
- Significant Characteristic relating to Process Control (SPC)
- Control Dimension relating to Form - Fit - Function as defined by Cole Hersee Company and/or the Customer

(Note that the identification of any Characteristics as being "Special" does not alter the requirement that ALL specified dimensions & tolerances must be met.)

Cole Hersee Co.
 20 Old Colony Ave., South Boston, MA, 02127
 Phn: 617-268-2100 Web: www.colehersee.com

Description: WINDSHIELD WIPER & WASHER SW. INTERMITTENT DELAY, 12V.D.C.

Drawing / Part No.: 75600-07

Current Rev.: J

4.75 .187
 8.58 .338
 8.71 .342
 11.43 .448
 46.68 1.838
 55.62 2.190
 727.00 5.00
 0.8mm² 18 GA
 2.0mm² 14 GA

COLE-HERSEE CO.

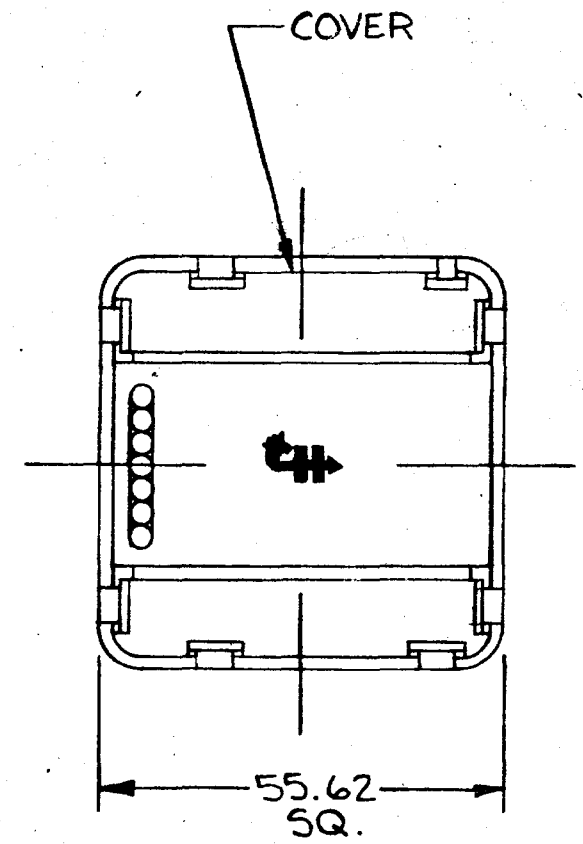
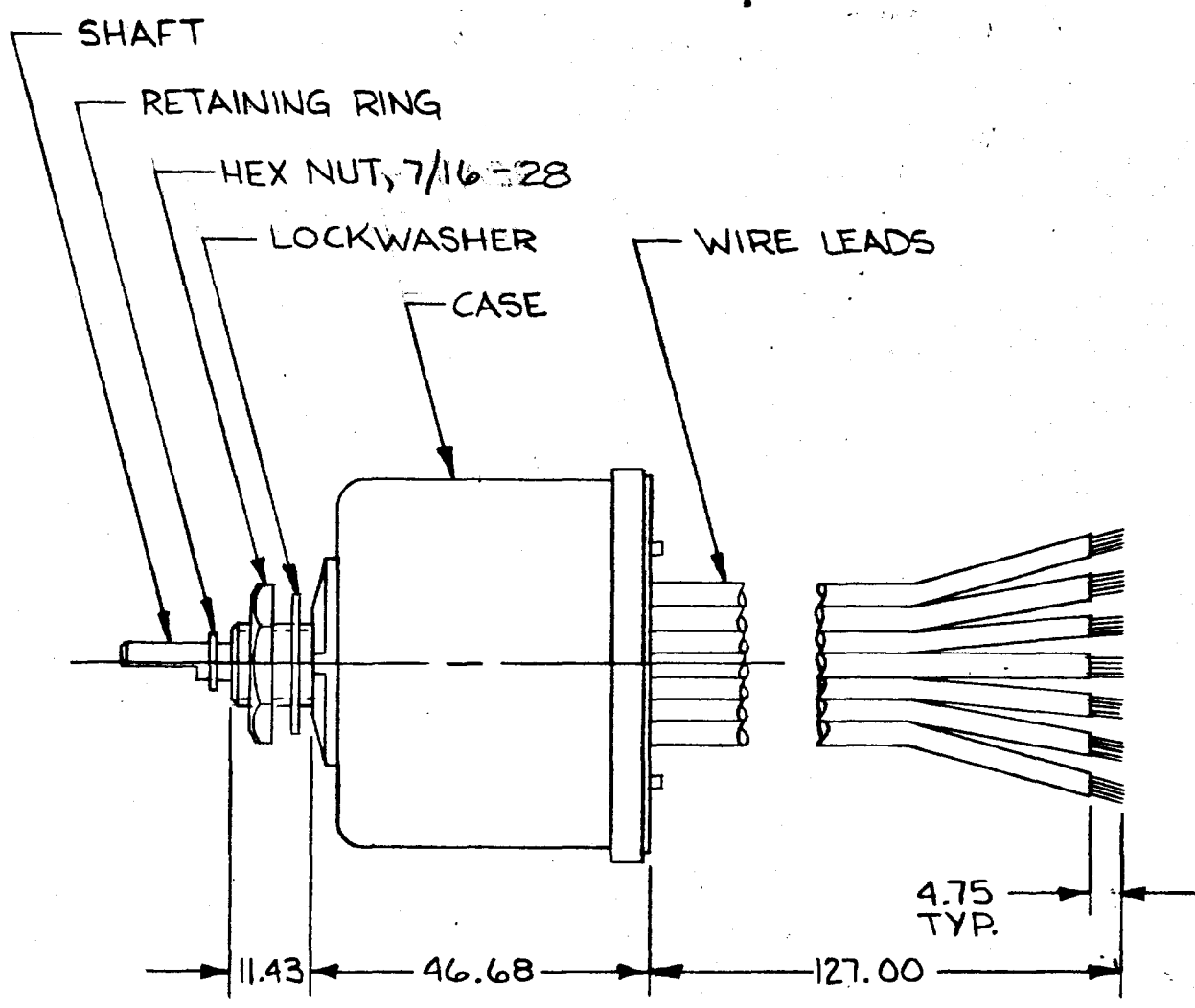
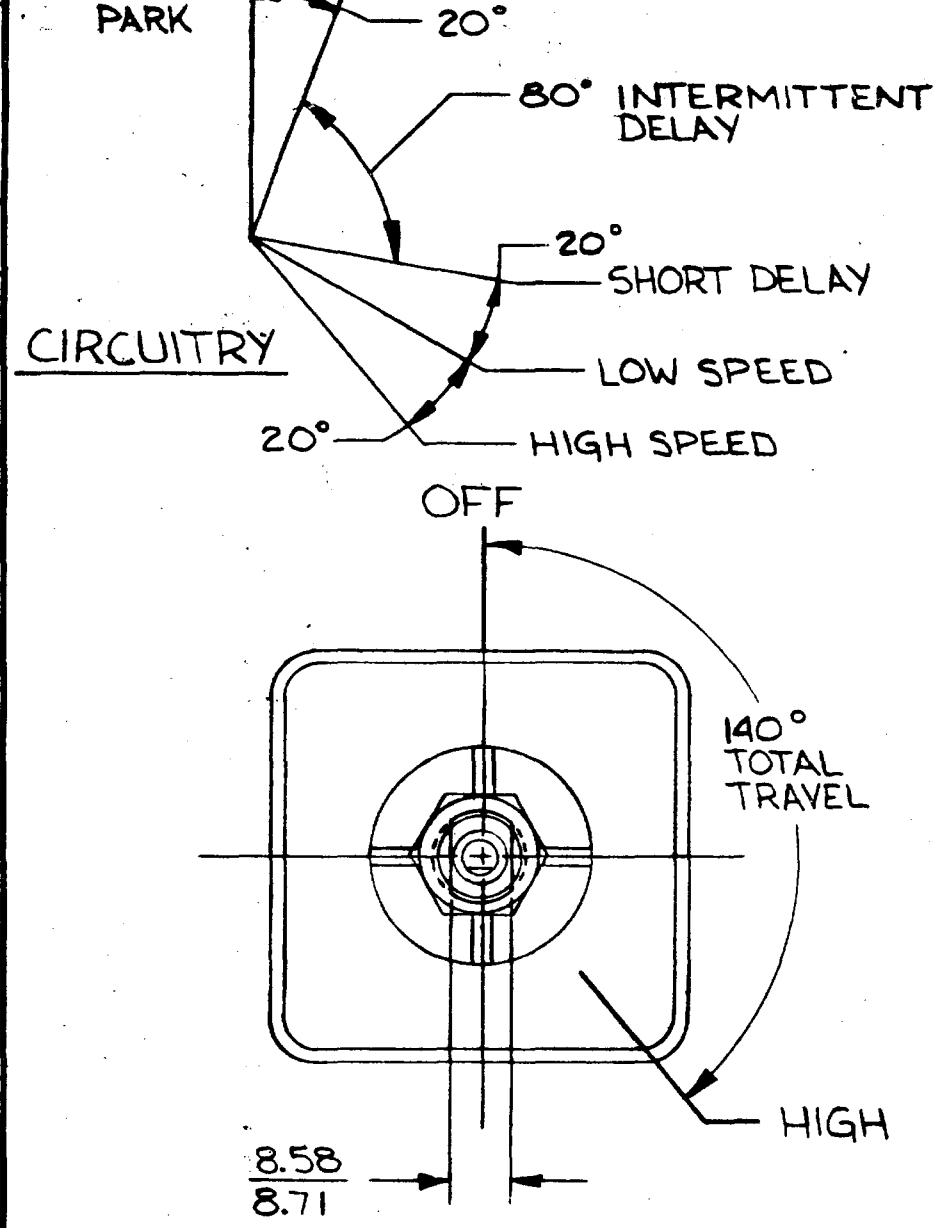

SWITCH CONNECTIONS		
COLOR	WIRE SIZE	CONNECT WIRE TO:
YELLOW	2.0mm ² (14 GA)	MOTOR LOW SPEED TERMINAL
WHITE	2.0mm ² (14 GA)	MOTOR HIGH SPEED TERMINAL
GREEN	2.0mm ² (14 GA)	MOTOR PARK TERMINAL
BLACK	0.8mm ² (18 GA)	GROUND (B-) THIS CONNECTION MUST BE MADE
BROWN	0.8mm ² (18 GA)	WASHER PUMP (B+ TERMINAL)
RED	2.0mm ² (14 GA)	B+ (THESE TWO WIRES MUST BE CONNECTED TOGETHER)
RED	0.8mm ² (18 GA)	

- NOTES:
- PUSH TO WASH, WASHER & WIPER CIRCUIT ACTIVATED (1-3 WIPES AFTER WASHER CIRCUIT IS DEACTIVATED).
 - ALL STEEL PARTS PLATED.
 - ALL DIMENSIONS ARE REF. ONLY.
 - 12 VOLTS D.C.
 - SEPARATE B+ AND GROUND CONNECTIONS MUST BE MADE TO THE WIPER MOTOR.

METRIC

LET.	WAS	DATE	BY	LET.	WAS	DATE	BY	MATERIAL	DRAWN	CHECKED	APPRVD.	SCALE	DATE DRAWN
								FINISH	LZ	76		1:1	3-18-87
										 <small>3910 LYNN AVENUE SOUTH BOSTON, MA 02117</small>		DATE BLUEPRINT	
							A	ECN 24882	7-22-91			WINDSHIELD WIPER & WASHER SWITCH	
								ISSUED	3-23-87			75601-06	

DO NOT SCALE

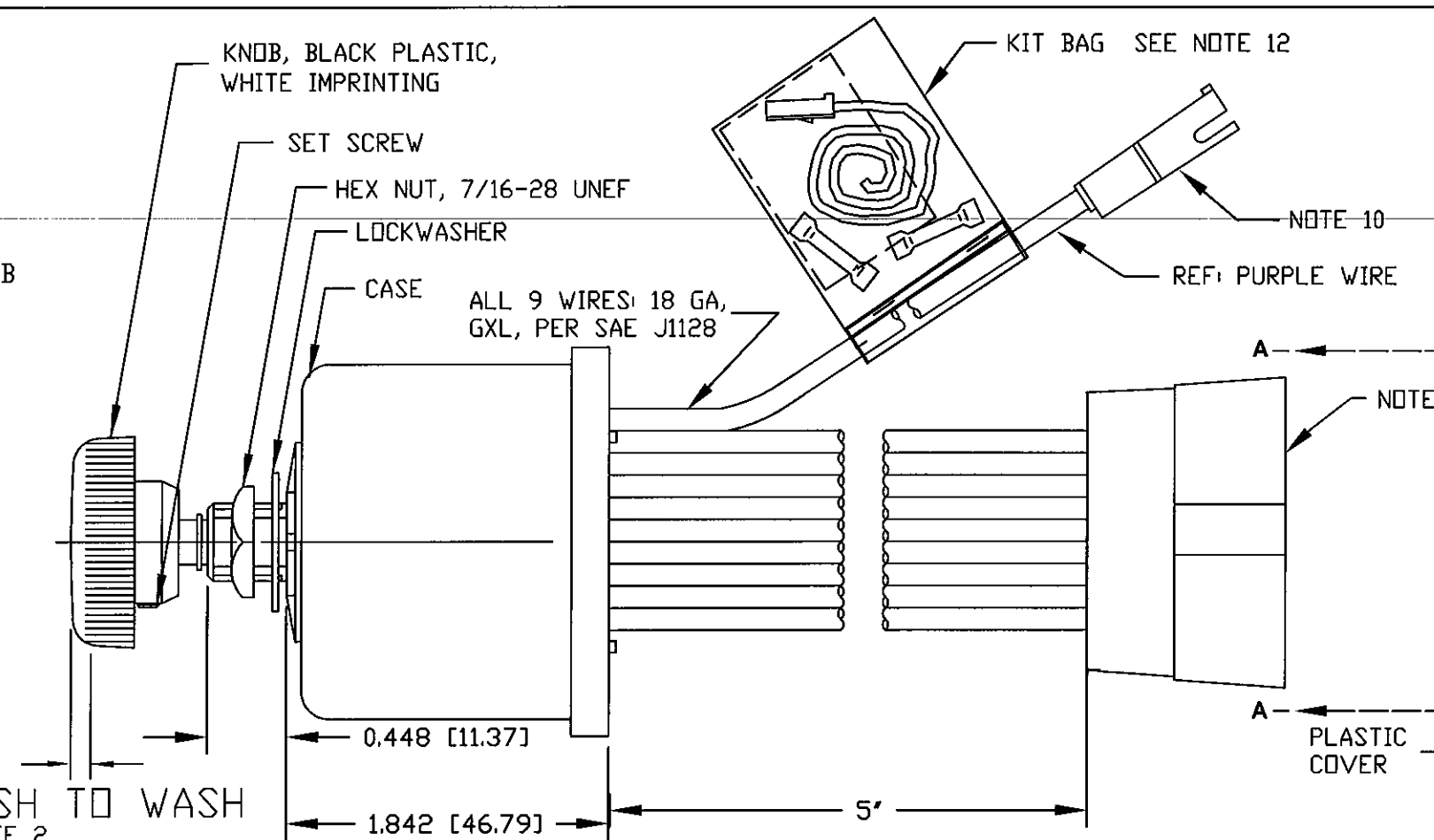
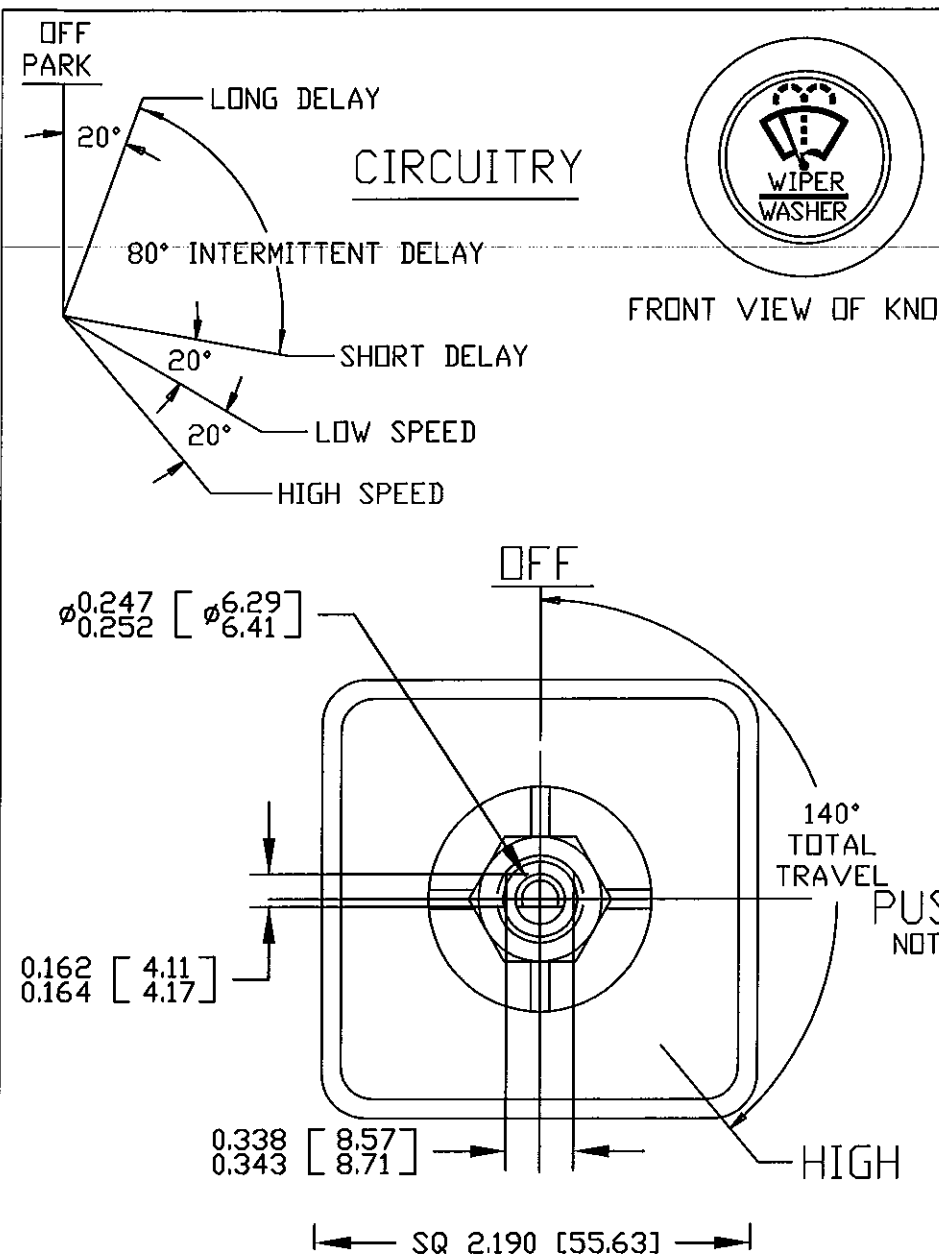

Revision Control Record			
Rev.	Description of Change	ECN No.	Date
A	NEW RELEASE	07475	12/04/07
B	SOFTWARE CHANGE	08085	01/31/08
C	BOM CHANGE	09587	01/13/10

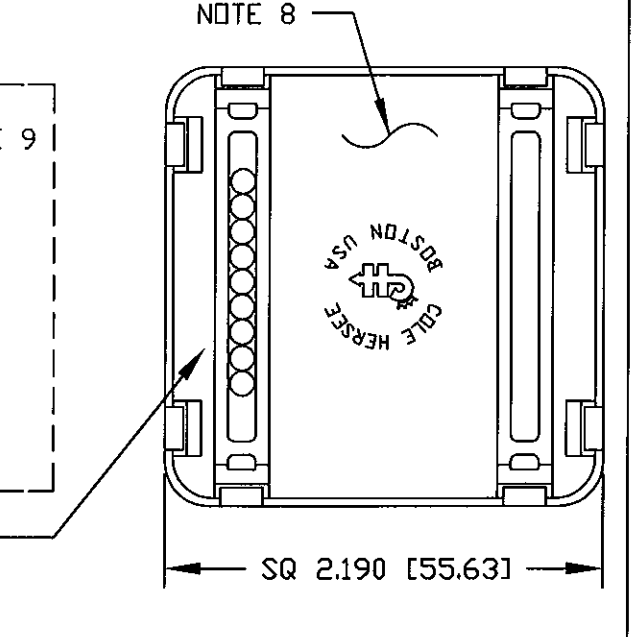

COLOR	FUNCTION	CONNECTOR	TERMINAL
RED	VBB (12V POWER)	8-PIN	A
GREY	HIGH-SPEED MOTOR #2	8-PIN	B
ORANGE	LOW-SPEED MOTOR #2	8-PIN	C
BLACK	GROUND (0V)	8-PIN	D
BLUE	PARK MOTOR #1 (SEE NOTE 11)	8-PIN	E
WHITE	HIGH-SPEED MOTOR#1	8-PIN	F
YELLOW	LOW-SPEED MOTOR #1	8-PIN	G
BROWN	WASHER	8-PIN	H
PURPLE	PARK MOTOR #2 (SEE NOTE 11)	1-PIN	

- NOTES:
- DESIGNED FOR 12V SYSTEM, DUAL MOTOR. MUST BE USED WITH NON-DYNAMIC PARK MOTORS ONLY.
 - PUSH TO WASH FUNCTION RESULTS IN 3 WIPES AFTER RELEASE OF PUSH SWITCH.
 - RATING: VOLTAGE OPERATING RANGE 9VDC TO 16VDC
 ROTARY SWITCH ACTUATION 20,000 CYCLES MINIMUM.
 MOTOR DRIVE: 10 AMPS PER MOTOR CONTINUOUS, START-UP/STALL/LOCKED-ROTOR 30 AMPS. SHORT-CIRCUIT PROOF.
 WASHER CIRCUIT 3 AMPS, PUSH SWITCH 20,000 CYCLES MINIMUM.
 - MICROPROCESSOR CONTROLLED, SOLID-STATE RELAY, CURRENT LIMIT SENSE CIRCUIT, REVERSE POLARITY PROTECTED
 - CONFORMS TO SAE J1455:
 4.11 GENERAL HEAVY DUTY TRUCK ELECTRICAL ENVIRONMENT.
 4.11.1 STEADY-STATE ELECTRICAL CHARACTERISTICS.
 4.11.2 TRANSIENT, NOISE AND ELECTROSTATIC CHARACTERISTICS.
 - INTERMITTENT DELAYS: 1, 2, 4, 7, 11 AND 16 SECONDS
 - ALL DIMENSIONS ARE REFERENCE ONLY UNLESS NOTED OTHERWISE.
 - COLE HERSEE PART NUMBER, REVISION, & DATE CODE STAMPED IN WHITE ON REAR PLASTIC COVER.
 - CONNECTOR, DELPHI: 8-PIN, PART# 2965972 (QTY 1)
 TERMINALS, DELPHI: 2965439 (QTY 8)
 - CONNECTOR, DELPHI: 1-PIN, PART# 8905650 (QTY 1)
 TERMINALS, DELPHI: 2965439 (QTY 1)
 - UNIT REQUIRES TWO SEPARATE WIRE CONNECTIONS TO MOTOR PARK SIGNALS.
 THIS MAY REQUIRE RE-WIRING VEHICLE HARNESS. DO NOT CONNECT PARK WIRES TOGETHER.
 NOTE THAT 1-PIN CONNECTOR (PURPLE WIRE) IS FOR PARK MOTOR #2.
 - WRAP PLASTIC BAG AROUND SWITCH PURPLE WIRE, FOLD AND STAPLE AS SHOWN.

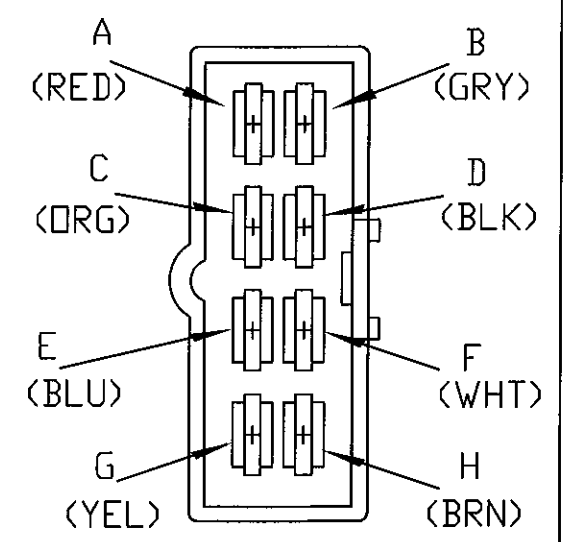

Tolerances Unless otherwise specifically noted, the following are default tolerances:
 * 2-place Decimal Dimensions +/- .02"
 * 3-place Decimal Dimensions +/- .005"
 * Angular Dimensions +/- 1.0 Deg.
 * Metric: Refer to equivalent English Dimension Tolerance
 >>> NOTE: All tolerances are Non-Cumulative. <<<

Dimensional Units All dimensions are expressed in inches except those shown in brackets (xxx) are expressed in millimeters

"REF." or an Asterisk (*) = Non-Toleranced Reference Dimension, shown for clarification purposes only.

Used On or Ref.: **EX28333** Scale: **1:1**

PROPRIETARY INFORMATION This Engineering Drawing, and the information contained herein, is proprietary to Cole Hersee Company and may not be disclosed, re-produced, or in any other way transferred or communicated to any other party without the express written consent of an authorized representative of Cole Hersee Company.

DESIGN CONTROL It is the responsibility of the individual using / referencing this drawing to assure that the noted design revision level agrees with the revision level of the Controlled Document (Master Drawing). This is a NON-CONTROLLED DOCUMENT unless otherwise specifically noted.

DO NOT SCALE - Dimensional variation may occur during printing / reproduction.

Drawn **JCS** Date **12/04/07**
 By: Drawn: Responsible Engineer: **JCS** Pg. **1**

Special Characteristics:

- Critical Characteristic, relating to Safety and/or Regulatory Compliance
- Significant Characteristic relating to Process Control (SPC)
- Control Dimension relating to Form - Fit - Function as defined by Cole Hersee Company and/or the Customer

(Note that the Identification of any Characteristics as being "Special" does not alter the requirement that ALL specified dimensions & tolerances must be met.)

Cole Hersee Co.
 20 Old Colony Ave., South Boston, MA, 02127
 Phn: 617-268-2100 Web: www.colehersee.com

Description:
WINDSHIELD WIPER CONTROLLER, DUAL-MOTOR, 12V, SSR, NON-DYNAMIC PARK MOTOR

Drawing / Part No.: **75601-14** **Current Rev.:** **C**

Revision Control Record

Rev.	Description of Change	ECN No.	Date
A	NEW RELEASE	07476	12/04/07
B	PROGRAM SOFTWARE	08085	01/31/08
C	BOM CHANGE	09587	01/13/10

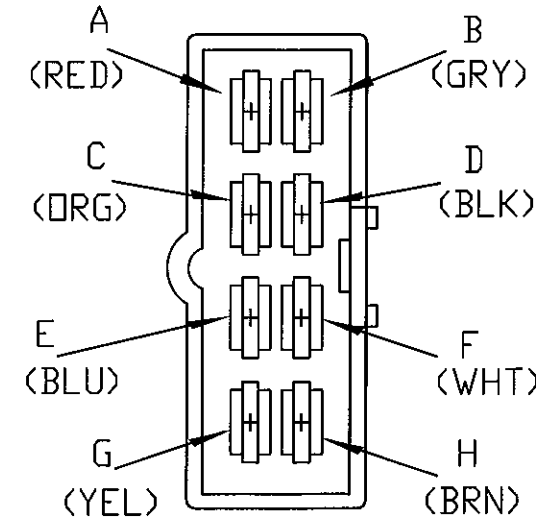
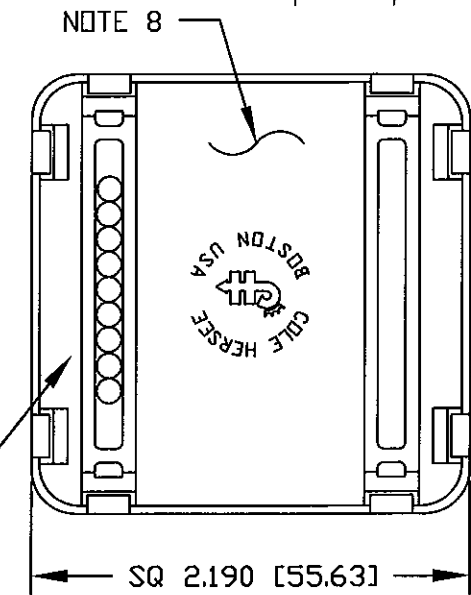
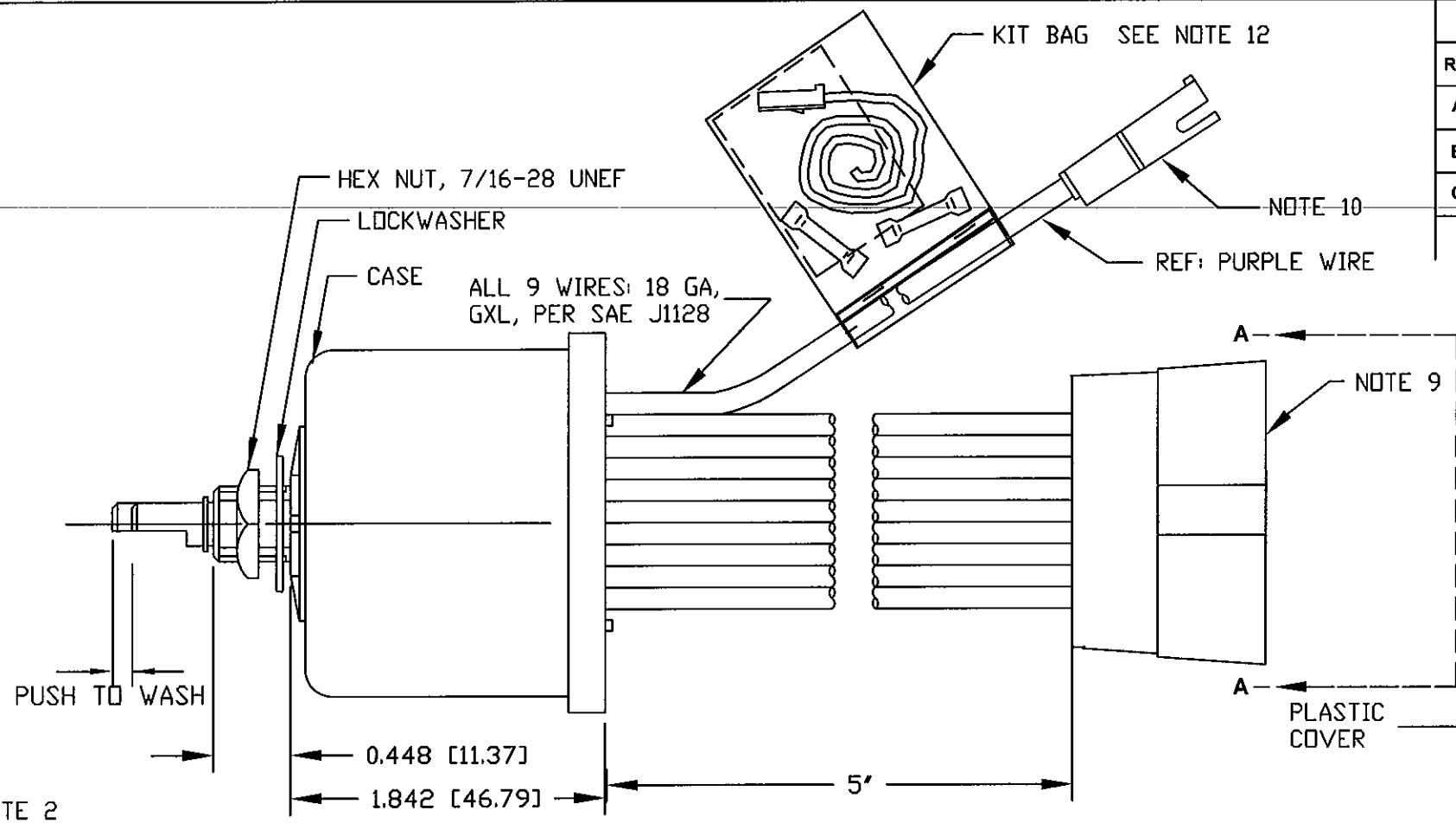
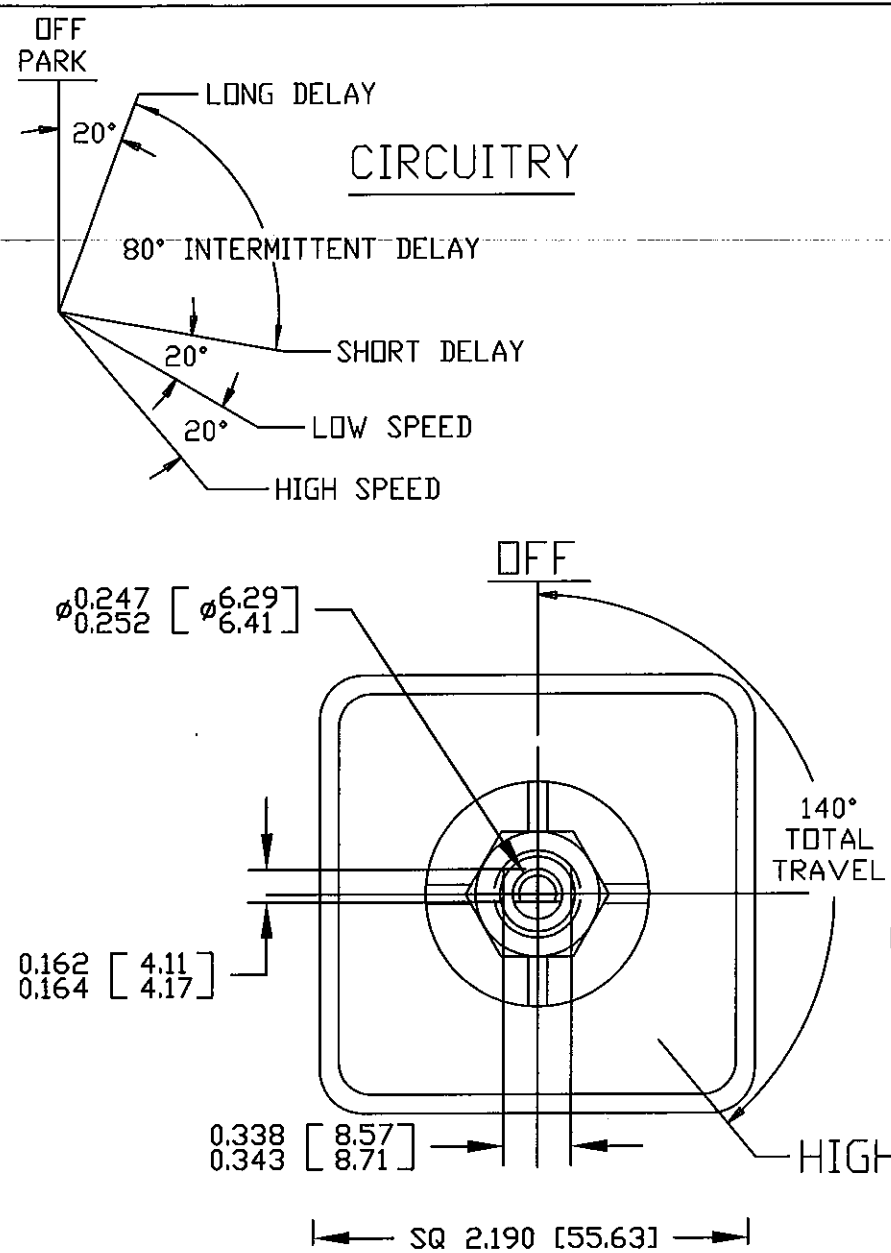

- NOTES:**
- DESIGNED FOR 12V SYSTEM, DUAL MOTOR. MUST BE USED WITH NON-DYNAMIC PARK MOTORS ONLY.
 - PUSH TO WASH FUNCTION RESULTS IN 3 WIPES AFTER RELEASE OF PUSH SWITCH.
 - RATING: VOLTAGE OPERATING RANGE 9VDC TO 16VDC
 ROTARY SWITCH ACTUATION 20,000 CYCLES MINIMUM.
 MOTOR DRIVE: 10 AMPS PER MOTOR CONTINUOUS. START-UP/STALL/LOCKED-ROTOR 30 AMPS. SHORT-CIRCUIT PROOF.
 WASHER CIRCUIT 3 AMPS, PUSH SWITCH 20,000 CYCLES MINIMUM.
 - MICROPROCESSOR CONTROLLED, SOLID-STATE RELAY, CURRENT LIMIT SENSE CIRCUIT, REVERSE POLARITY PROTECTED
 - CONFORMS TO SAE J1455:
 4.11 GENERAL HEAVY DUTY TRUCK ELECTRICAL ENVIRONMENT.
 4.11.1 STEADY-STATE ELECTRICAL CHARACTERISTICS.
 4.11.2 TRANSIENT, NOISE AND ELECTROSTATIC CHARACTERISTICS.
 - INTERMITTENT DELAYS: 1, 2, 4, 7, 11 AND 16 SECONDS
 - ALL DIMENSIONS ARE REFERENCE ONLY UNLESS NOTED OTHERWISE.
 - COLE HERSEE PART NUMBER, REVISION, & DATE CODE STAMPED IN WHITE ON REAR PLASTIC COVER.
 - CONNECTOR, DELPHI: 8-PIN, PART# 2965972 (QTY 1)
 TERMINALS, DELPHI: 2965439 (QTY 8)
 - CONNECTOR, DELPHI: 1-PIN, PART# 8905650 (QTY 1)
 TERMINALS, DELPHI: 2965439 (QTY 1)
 - UNIT REQUIRES TWO SEPARATE WIRE CONNECTIONS TO MOTOR PARK SIGNALS.
 THIS MAY REQUIRE RE-WIRING VEHICLE HARNESS. DO NOT CONNECT PARK WIRES TOGETHER.
 NOTE THAT 1-PIN CONNECTOR (PURPLE WIRE) IS FOR PARK MOTOR #2.
 - WRAP PLASTIC BAG AROUND SWITCH PURPLE WIRE, FOLD AND STAPLE AS SHOWN.

COLOR	FUNCTION	CONNECTOR	TERMINAL
RED	VBB (12V POWER)	8-PIN	A
GREY	HIGH-SPEED MOTOR #2	8-PIN	B
ORANGE	LOW-SPEED MOTOR #2	8-PIN	C
BLACK	GROUND (0V)	8-PIN	D
BLUE	PARK MOTOR #1 (SEE NOTE 11)	8-PIN	E
WHITE	HIGH-SPEED MOTOR#1	8-PIN	F
YELLOW	LOW-SPEED MOTOR #1	8-PIN	G
BROWN	WASHER	8-PIN	H
PURPLE	PARK MOTOR #2 (SEE NOTE 11)	1-PIN	

Tolerances Unless otherwise specifically noted, the following are default tolerances:
 * 2-place Decimal Dimensions +/- .02"
 * 3-place Decimal Dimensions +/- .005"
 * Angular Dimensions +/- 1.0 Deg.
 * Metric: Refer to equivalent English Dimension Tolerance
 >>> NOTE: All tolerances are Non-Cumulative. <<<

Dimensional Units All dimensions are expressed in inches except those shown in brackets (xxx) are expressed in millimeters

"REF." or an Asterisk (*) = Non-Toleranced Reference Dimension, shown for clarification purposes only.

Used On: **EX28333** Scale: **1:1**

PROPRIETARY INFORMATION This Engineering Drawing, and the information contained herein, is proprietary to Cole Hersee Company and may not be disclosed, re-produced, or in any other way transferred or communicated to any other party without the express written consent of an authorized representative of Cole Hersee Company.

DESIGN CONTROL It is the responsibility of the individual using / referencing this drawing to assure that the noted design revision level agrees with the revision level of the Controlled Document (Master Drawing). This is a NON-CONTROLLED DOCUMENT unless otherwise specifically noted.

DO NOT SCALE - Dimensional variation may occur during printing / reproduction.

Drawn By: **JCS** Date Drawn: **12/04/07**

Special Characteristics:

- Critical Characteristic, relating to Safety and/or Regulatory Compliance
- Significant Characteristic relating to Process Control (SPC)
- Control Dimension relating to Form - Fit - Function as defined by Cole Hersee Company and/or the Customer

(Note that the Identification of any Characteristics as being "Special" does not alter the requirement that ALL specified dimensions & tolerances must be met.)

Responsible Engineer: **JCS** Pg. **1**

Cole Hersee Co.
 20 Old Colony Ave., South Boston, MA, 02127
 Phn: 617-268-2100 Web: www.colehersee.com

Description:
WINDSHIELD WIPER CONTROLLER, DUAL-MOTOR, 12V, SSR, NON-DYNAMIC PARK MOTOR

Drawing / Part No.: **75601-15** Current Rev.: **C**

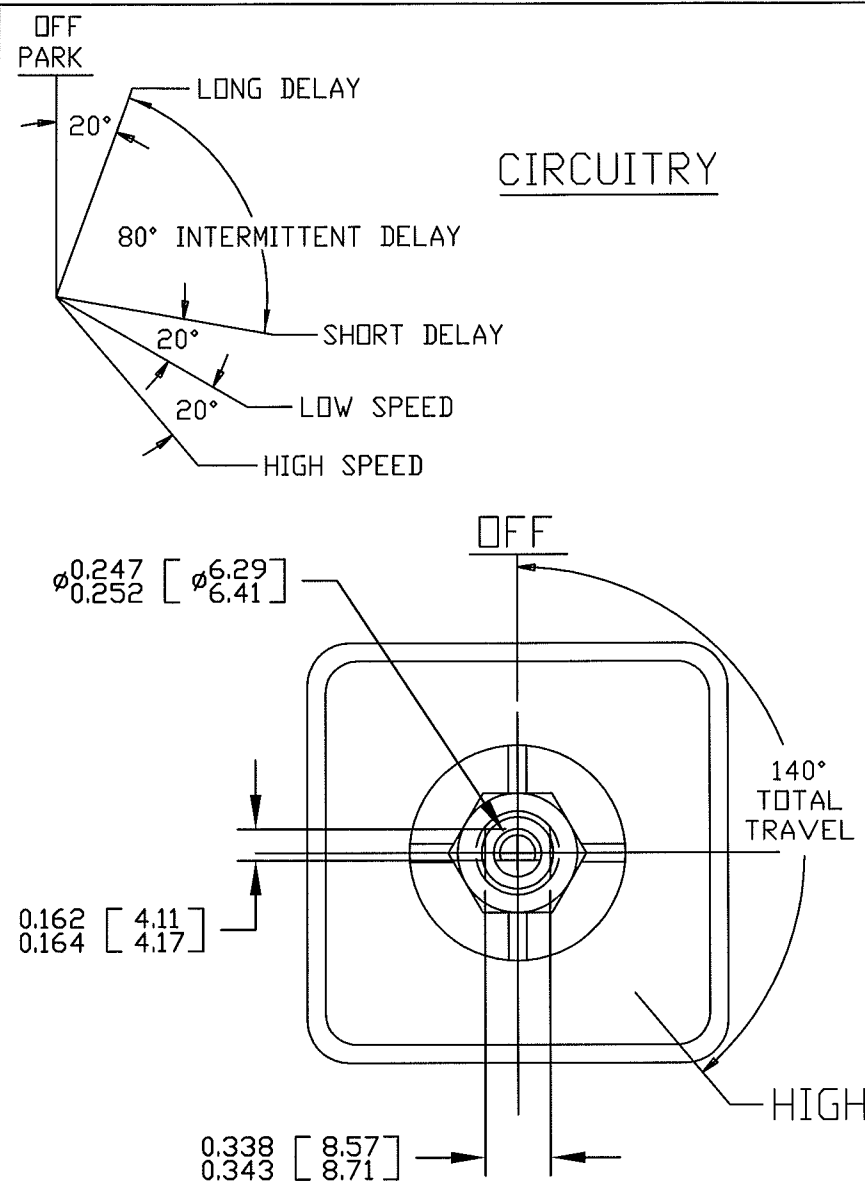

Revision Control Record			
Rev.	Description of Change	ECN No.	Date
H	BOM CHANGE	09588	01/18/10
J	CHANGE NOTE 3	13055	02/07/13

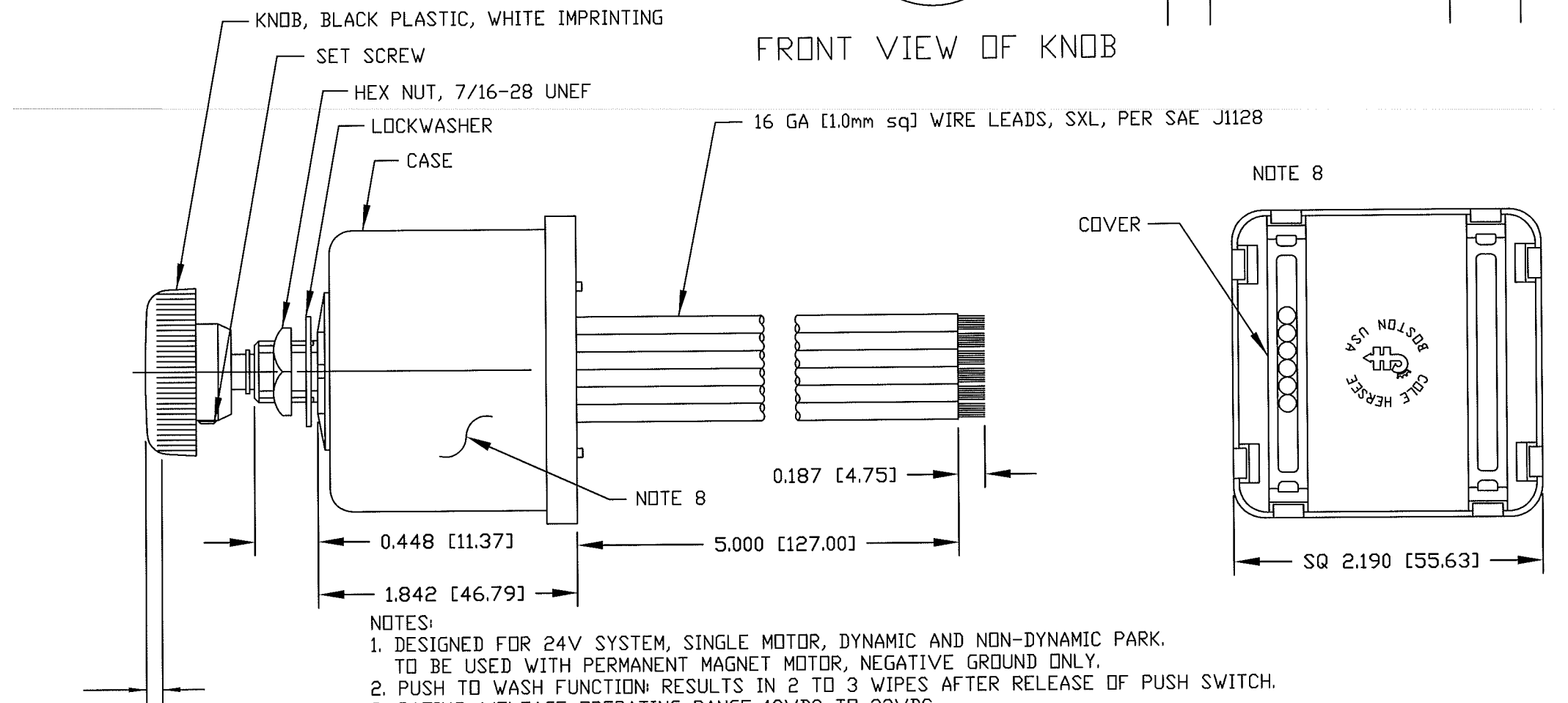

PUSH TO WASH
NOTE 2

- NOTES:
- DESIGNED FOR 24V SYSTEM, SINGLE MOTOR, DYNAMIC AND NON-DYNAMIC PARK. TO BE USED WITH PERMANENT MAGNET MOTOR, NEGATIVE GROUND ONLY.
 - PUSH TO WASH FUNCTION: RESULTS IN 2 TO 3 WIPES AFTER RELEASE OF PUSH SWITCH.
 - RATING: VOLTAGE OPERATING RANGE 18VDC TO 32VDC
ROTARY SWITCH ACTUATION 20,000 CYCLES MINIMUM.
MOTOR DRIVE: 15 AMPS CONTINUOUS, START-UP/STALL/LOCKED-ROTOR 50 AMPS, SHORT-CIRCUIT PROTECTED.
WASHER CIRCUIT 3 AMPS, PUSH SWITCH 20,000 CYCLES MINIMUM.
 - MICROPROCESSOR CONTROLLED, SOLID-STATE RELAY, CURRENT LIMIT SENSE CIRCUIT, REVERSE POLARITY PROTECTED
 - CONFORMS TO SAE J1455:
4.11 GENERAL HEAVY DUTY TRUCK ELECTRICAL ENVIRONMENT.
4.11.1 STEADY-STATE ELECTRICAL CHARACTERISTICS.
4.11.2 TRANSIENT, NOISE AND ELECTROSTATIC CHARACTERISTICS.
 - ENVIRONMENTAL EXTREMES BY LOCATION.
5.2 INTERIOR-FORWARD.
 - ALL STEEL PARTS PLATED.
 - ALL DIMENSIONS ARE REFERENCE ONLY UNLESS NOTED OTHERWISE.
 - COLE HERSEE PART NUMBER, REVISION, & DATE CODE MARKED AT RANDOM ON CASE.

COLOR	CONNECT WIRE TO:
YELLOW	MOTOR LOW SPEED TERMINAL
WHITE	MOTOR HIGH SPEED TERMINAL
BLUE	MOTOR PARK TERMINAL
BLACK	GROUND (B-) THIS CONNECTION MUST BE MADE
BROWN	WASHER PUMP (B+ TERMINAL)
RED	B+

SEPARATE B+ AND GROUND CONNECTIONS MUST BE MADE TO THE WIPER MOTOR

Tolerances Unless otherwise specifically noted, the following are default tolerances:
 * 2-place Decimal Dimensions +/- .02"
 * 3-place Decimal Dimensions +/- .005"
 * Angular Dimensions +/- 1.0 Deg.
 * Metric: Refer to equivalent English Dimension Tolerance
 >>> NOTE: All tolerances are Non-Cumulative. <<<

Dimensional Units All dimensions are expressed in inches except those shown in brackets (xx) are expressed in millimeters

"REF." or an Asterisk (*) = Non-Toleranced Reference Dimension, shown for clarification purposes only.

Used On **EX-26548** Scale: **1:1**

PROPRIETARY INFORMATION This Engineering Drawing, and the information contained herein, is proprietary to Cole Hersee Company and may not be disclosed, re-produced, or in any other way transferred or communicated to any other party without the express written consent of an authorized representative of Cole Hersee Company.

DESIGN CONTROL It is the responsibility of the individual using / referencing this drawing to assure that the noted design revision level agrees with the revision level of the Controlled Document (Master Drawing). This is a NON-CONTROLLED DOCUMENT unless otherwise specifically noted.

DO NOT SCALE - Dimensional variation may occur during printing / reproduction.

Drawn **ZU** Date **03/13/87**

Special Characteristics:

- Critical Characteristic, relating to Safety and/or Regulatory Compliance
- Significant Characteristic relating to Process Control (SPC)
- Control Dimension relating to Form - Fit - Function as defined by Cole Hersee Company and/or the Customer

(Note that the identification of any Characteristics as being "Special" does not alter the requirement that ALL specified dimensions & tolerances must be met.)

Responsible Engineer: **Pg. 1**

Cole Hersee Co.
 20 Old Colony Ave., South Boston, MA, 02127
 Phn: 617-268-2100 Web: www.colehersee.com

Description: WINDSHIELD WIPER & WASHER SW. INTERMITTENT DELAY, 24V.D.C.

Drawing / Part No.: **75602-04**

Current Rev.: **J**

X-ON Electronics

Largest Supplier of Electrical and Electronic Components

Click to view similar products for [Rotary Switches category](#):

Click to view products by [Littelfuse manufacturer](#):

Other Similar products are found below :

[57HS22-02-2-06N](#) [57M22-02B16N](#) [57M22-09A16N](#) [M3786/4-0881](#) [M3786/4-3267](#) [M3786/4-5568](#) [M3786/4-6029](#) [71ESF30-05204N](#)
[MC06L1NCGF](#) [84986-26](#) [9003K2C003GA](#) [PLR3251](#) [PLR3262](#) [PS3](#) [A0142M2SP](#) [A029303](#) [R2AA4455NNNN](#) [R2BB4455NNNN](#) [DR75-](#)
[AMSF-10R-B](#) [14-520.0360](#) [1703.3201](#) [HW1MS-0202-101](#) [24002-03S](#) [A029101](#) [ACSNO-129-YB-C1014](#) [ACSNO-134-RR-YB-C1005](#)
[ACSNO-353-SB-C3016](#) [1825537-4](#) [T505](#) [T505E](#) [24005-03N](#) [H10207RR01Q](#) [M3786/39-4ZC](#) [M3786/4-0002](#) [M3786/4-0630](#) [M3786/4-](#)
[1028L](#) [M3786/4-1233L](#) [M3786/4-3044](#) [M3786/4-3129](#) [M3786/4-5008L](#) [M3786/4-5256](#) [MC6CX1A502X009](#) [42HS36-01-1-06N](#) [42P36-](#)
[03B10S](#) [44MBS60-04-2-03N](#) [44MG90-02-1-02N](#) [50KMT90-01-2-02N](#) [51A22-01-1-16S](#) [51CDP30-01PAJN](#) [51KSP30-01D04N](#)